

INSTRUCTION MANUAL

CUTTING TOOL BROKEN DETECTING SWITCH TLPS, MTLPS, UTLPS

- Read this manual carefully and thoroughly before using this product.
- Pay extra attention to the instructions concerning safety.
- After reading this manual, keep it in a safe and convenient place.

6th Edition

CKD Corporation

For Safety Use

To use this product safely, basic knowledge of pneumatic equipment, including materials, piping, electrical system and mechanism, is required (to the level pursuant to JIS B 8370 Pneumatic System Rules).

We do not bear any responsibility for accidents caused by any person without such knowledge or arising from improper operation.

Our customers use this product for a very wide range of applications, and we cannot keep track of all of them. Depending on operating conditions, the product may fail to operate to maximum performance, or cause an accident. Thus, before placing an order, examine whether the product meets your application, requirements, and how to use it.

This product incorporates many functions and mechanisms to ensure safety. However, improper operation could result in an accident. To prevent such accidents, **read this operation manual carefully for proper operation.**

Observe the cautions on handling described in this manual, as well as the following instructions:



Precautions

- This product is designed for air and non-corrosive and non-combustible gasses, such as N₂. Do not use it with corrosive and combustible gasses.
- Do not touch electric wiring connections (exposed live parts) : this will cause an electric shock. During wiring, keep the power off.

Also, do not touch these live parts with wet hands.

INDEX

TLPS, MTLPS, UTLPS
CUTTING TOOL BROKEN DETECTING SWITCH
Manual No. SM-281640-A

1. PRODUCT		
1.1 Specification	-----	1
1.2 External dimension	-----	2
2. CAUTIONS	-----	13
3. OPERATION		
3.1 Adjustment	-----	16
3.2 Notes on use	-----	17
4. INSTALLATION		
4.1 Installation	-----	18
4.2 Wiring	-----	20
5. MAINTENANCE		
5.1 Manifold Installation	-----	22
5.2 Disassembly	-----	22
6. MODEL CODE	-----	24

Issued Jul.28.2001
Revision Apr.13.2010
Revision Nov.01.2011
Revision Oct.31.2014



1. Product
 1.1 Specification
 1.1.1 Single Type

Descriptions		TLPS-03			
Orifice		φ 0.3			
Working fluid		Clean compressed air (must be oil free)			
Working Pressure(Note2) (kPa)		50 to 200 (recommended 100)			
Detection cutting tool diameter (mm)		φ 0.3 to 30			
Power supply voltage (V)		10.2~26.4 DV			
Current consumption (mA)		15 or less (at 24V DC)			
Output style		NPN , PNP open collector			
Output rated		30V DC, 100mA or less			
Internal voltage drop (V)		2.0V or less (100mA)			
Indicator light and signal	At drill broken	Yellow light ON, output ON			
	At drill normal	Yellow light OFF, output OFF			
Cutting edge detecting position		1mm and over from end			
Insulation resistance		10MΩ and over with 500V DC mega			
Withstand voltage		No failure impressed at 1000V AC for one minute			
Vibration resistance (m/ s ²)		98			
Ambient temperature (°C)		5 to 60			
Degree of protection(Note1)		IP67 or equivalent(connector type), IP64 or equivalent (DIN)			
Piping size (mm)		Inner diameter 4			
Port size		Detection port Rc1/8, supply port Rc1/4, Gauge port Rc1/4			
Weight(g)		300(electric connection C0)			
Standards		CE marking products			
Air consumption L/min(ANR) <small>Air consumption value when CKD standard nozzle is selected.</small>	Nozzle type		TLPS-J0310	TLPS-J0510	TLPS-J0715
	Working pressure	50 kPa	2.8	4.8	6.6
		100 kPa	4.2	7.2	9.7
		200 kPa	6.6	11.1	15.1

Note1: This product must be used under the following conditions:

- (1) Piping and wiring must be completed and pressure applied.
- (2) A waterproof bushing must be used on the wires to the terminal box.

Note2: If the nozzle clogs, supply pressure should be set between 100 and 200 kPa.

1.1.3 Manifold Type

Basic specification except for protection structure is as same as single type.

Protection Structure

Connecting Option	Protection Structure
T※	IP66
CT※	IP67
F※	IP64
C※	IP67

1.1.4 Unit Type

Basic specification is as same as single type.

Protection structure is as same as manifold type.

But it is not applicable to solenoid valve and regulator.



1.2 External dimension

1.2.1 Single Type

1.2.1.1 Goods for the common terminal box

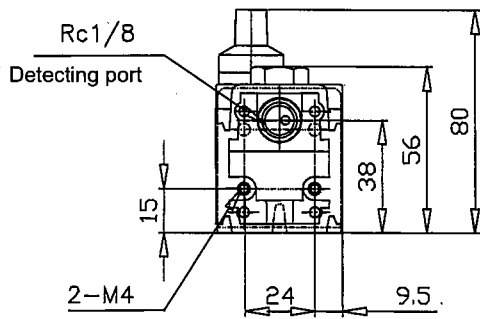
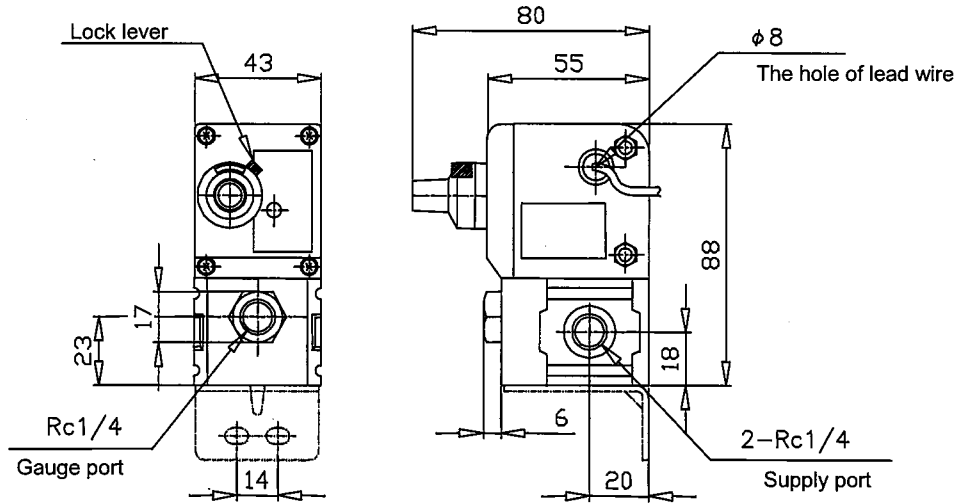

1.2.1.2 DIN-terminal

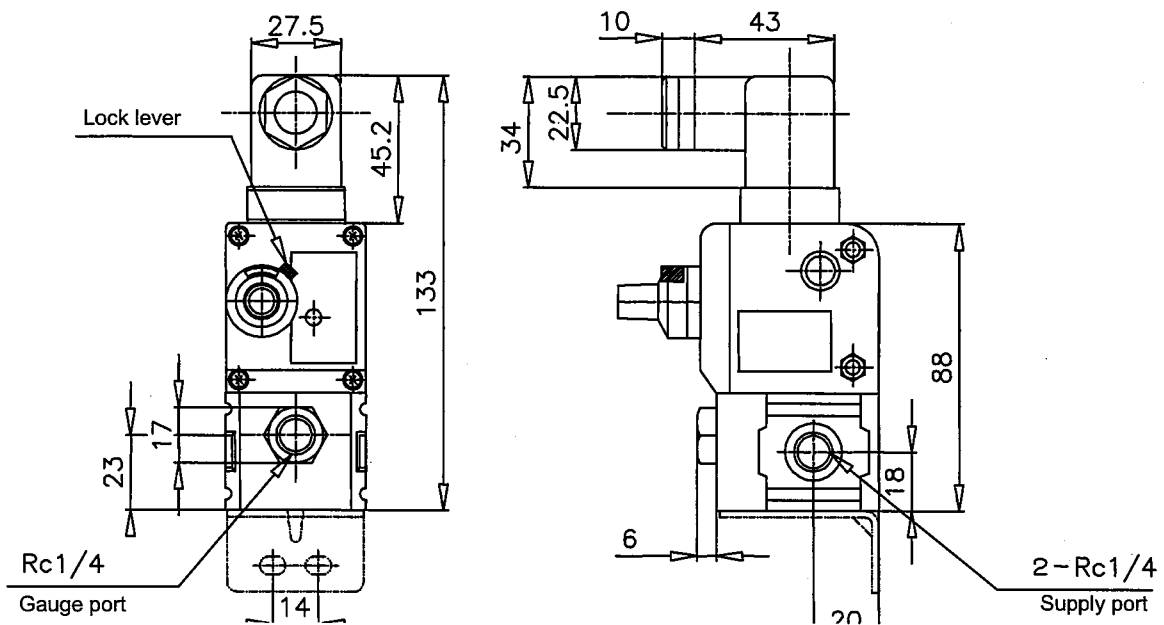

1.2.1.3 M12-connector

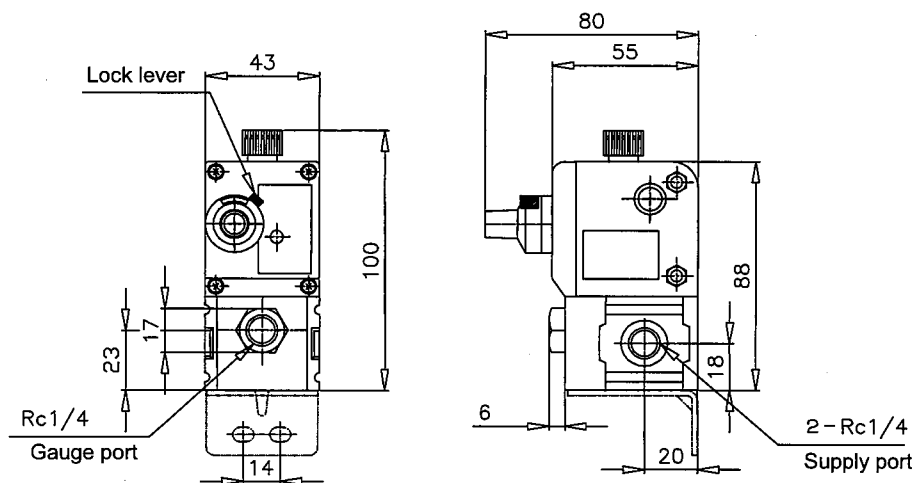

1.2.1.4 M12-connector Common terminal box

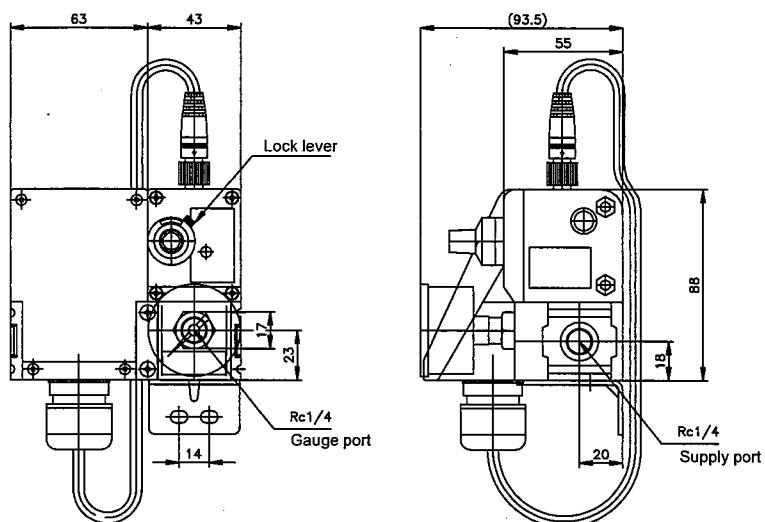

1.2.1.5 Lead wire type common terminal box

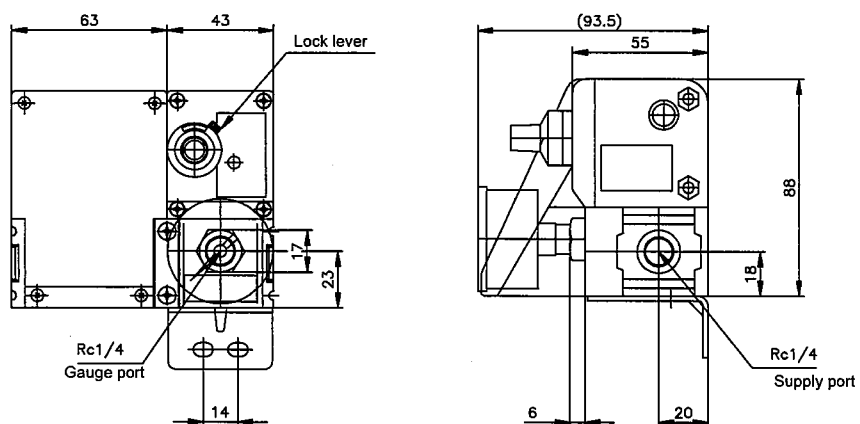



1.2.2 Manifold

1.2.2.1 DIN-terminal (F)

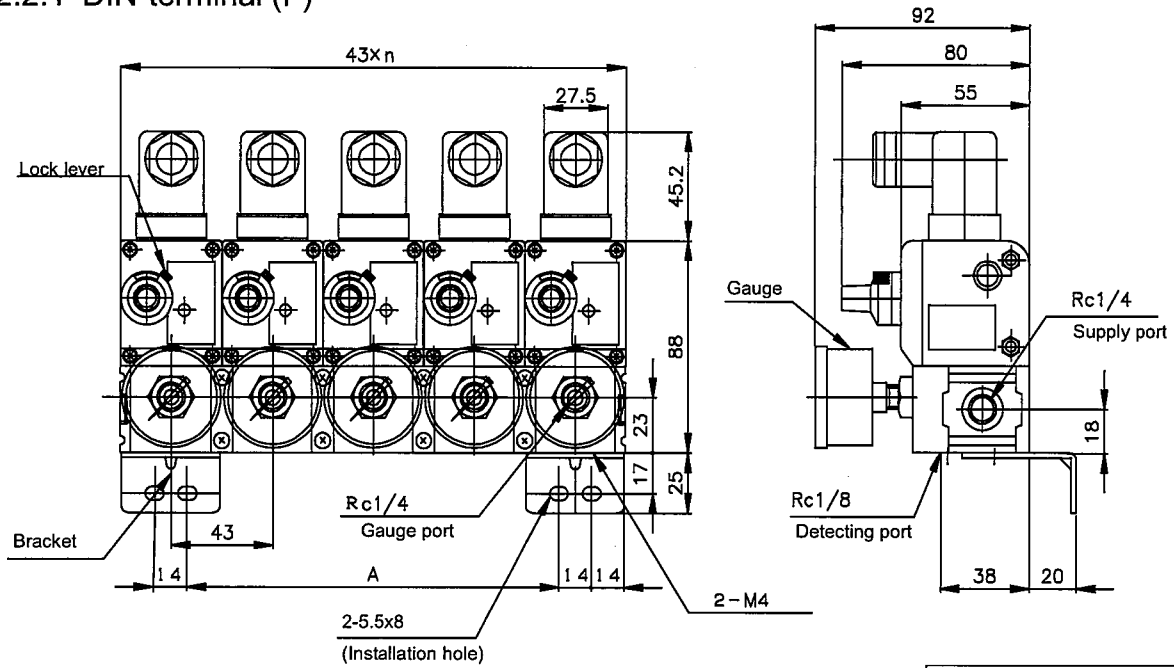

Nos. of station (n)	A
2	29
3	72
4	115
5	158

1.2.2.2 M12-connector (C)

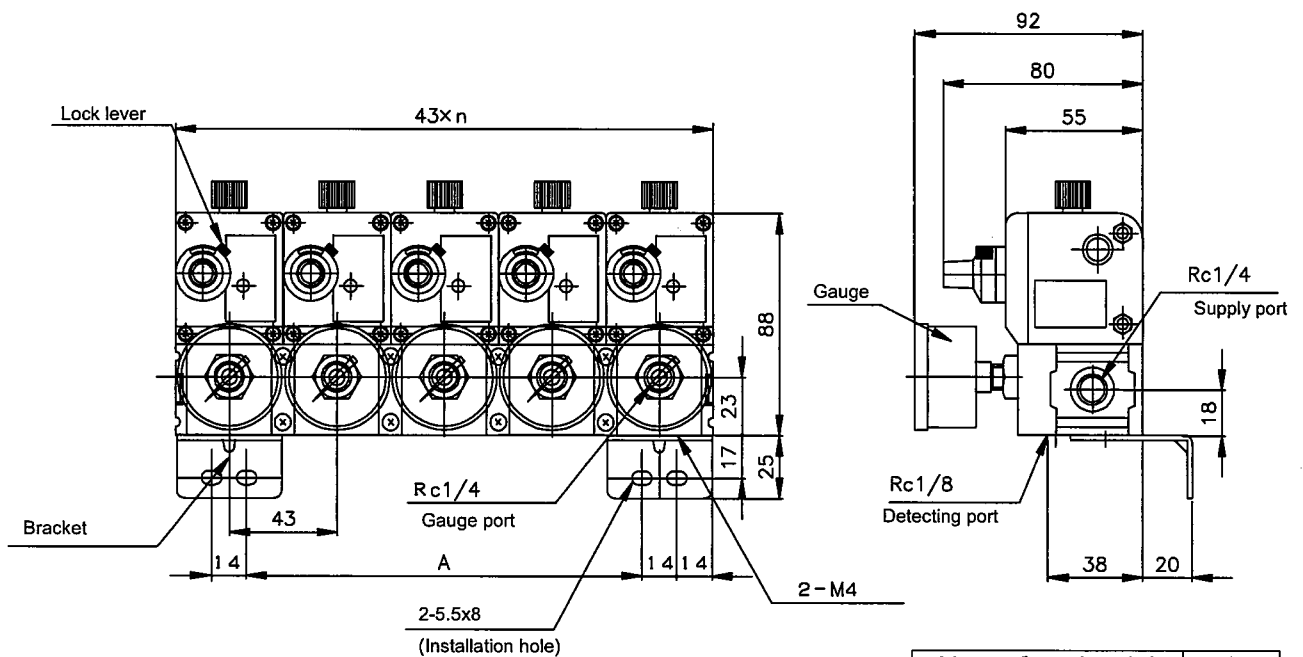

Nos. of station (n)	A
2	29
3	72
4	115
5	158

1.2.2.3 M12-connector type common terminal box (CTL,CTR)

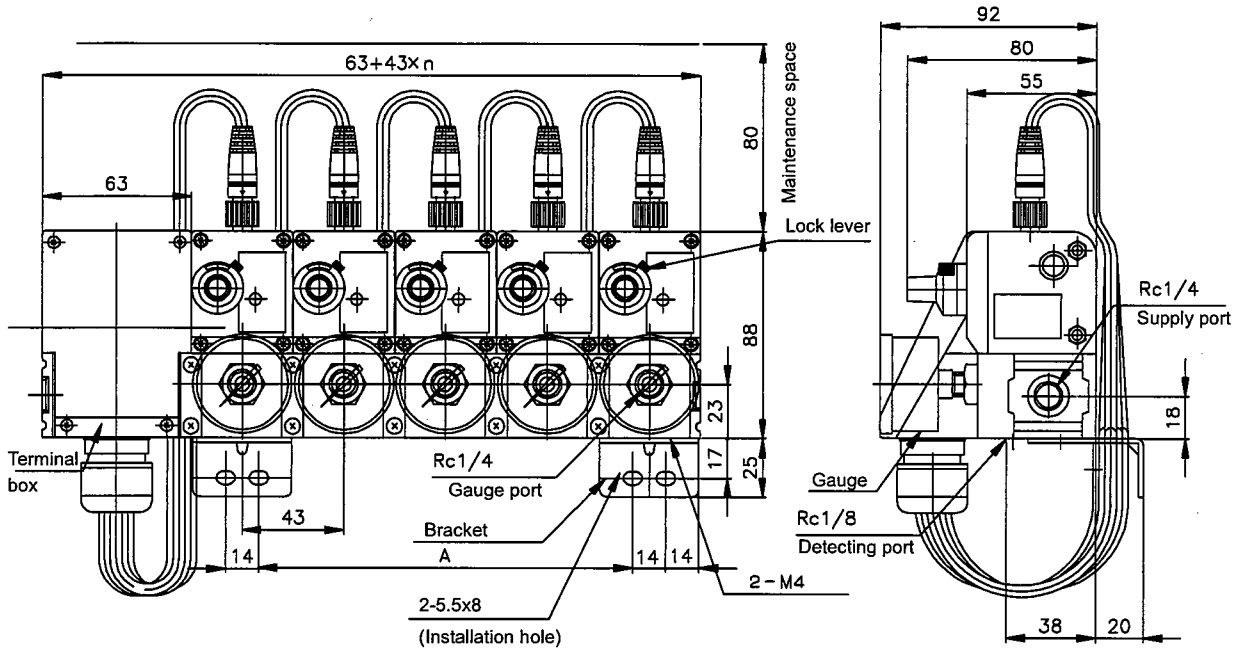

Nos. of station (n)	A
2	29
3	72
4	115
5	158

1.2.2.4 Lead wire type common terminal box (TL,TR)

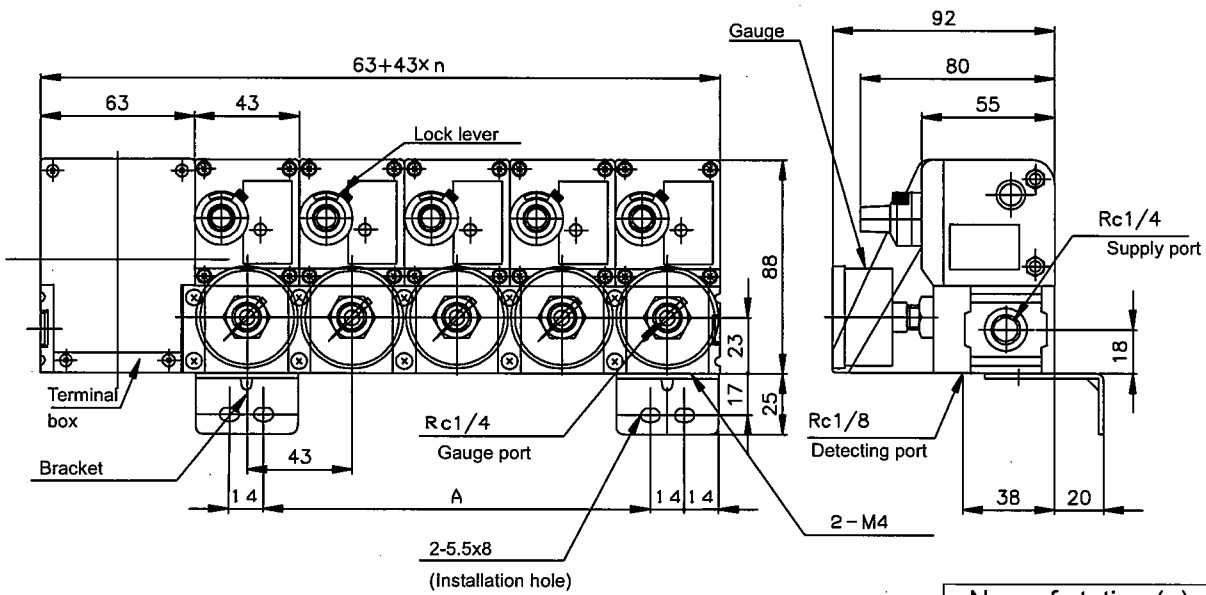

Nos. of station (n)	A
2	29
3	72
4	115
5	158



1.2.3 Unit

1.2.3.1 DIN-terminal box (F)

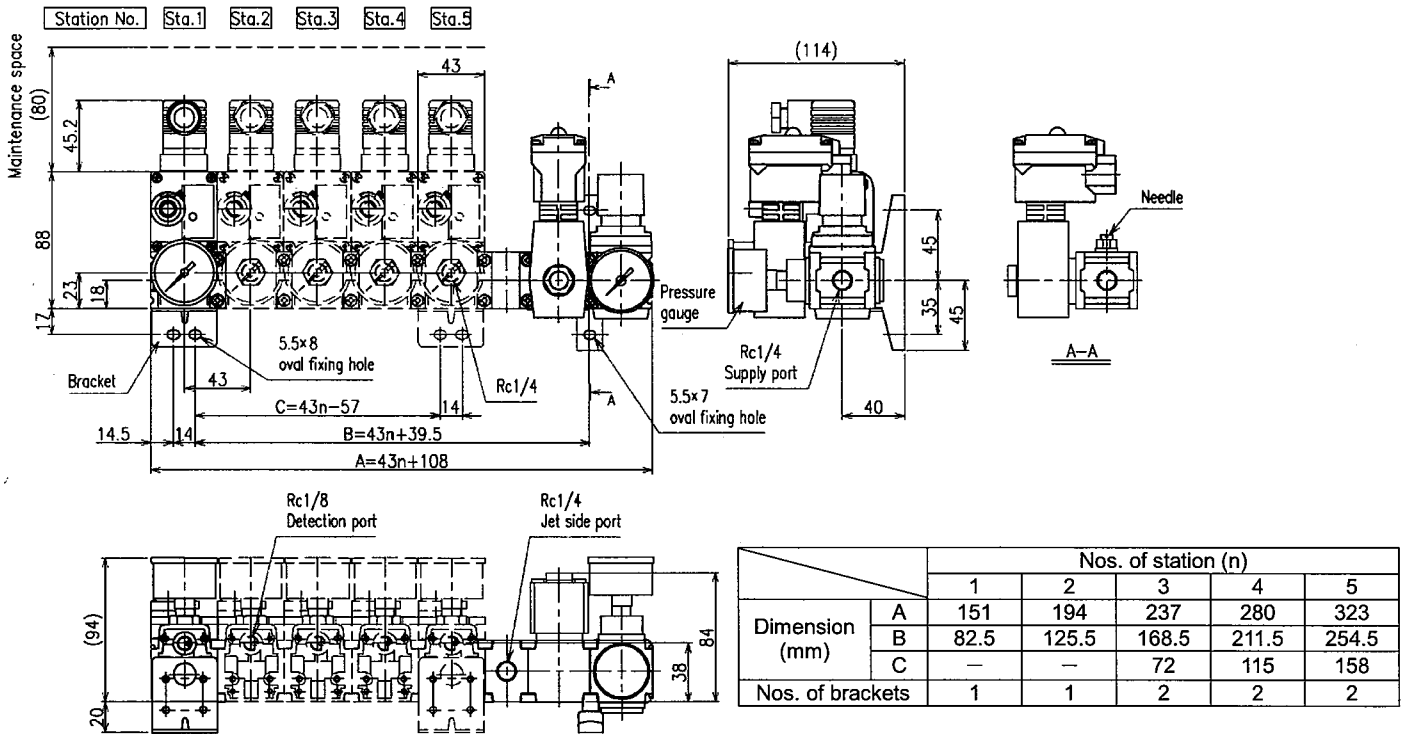

1.2.3.2 M12-connector (C)

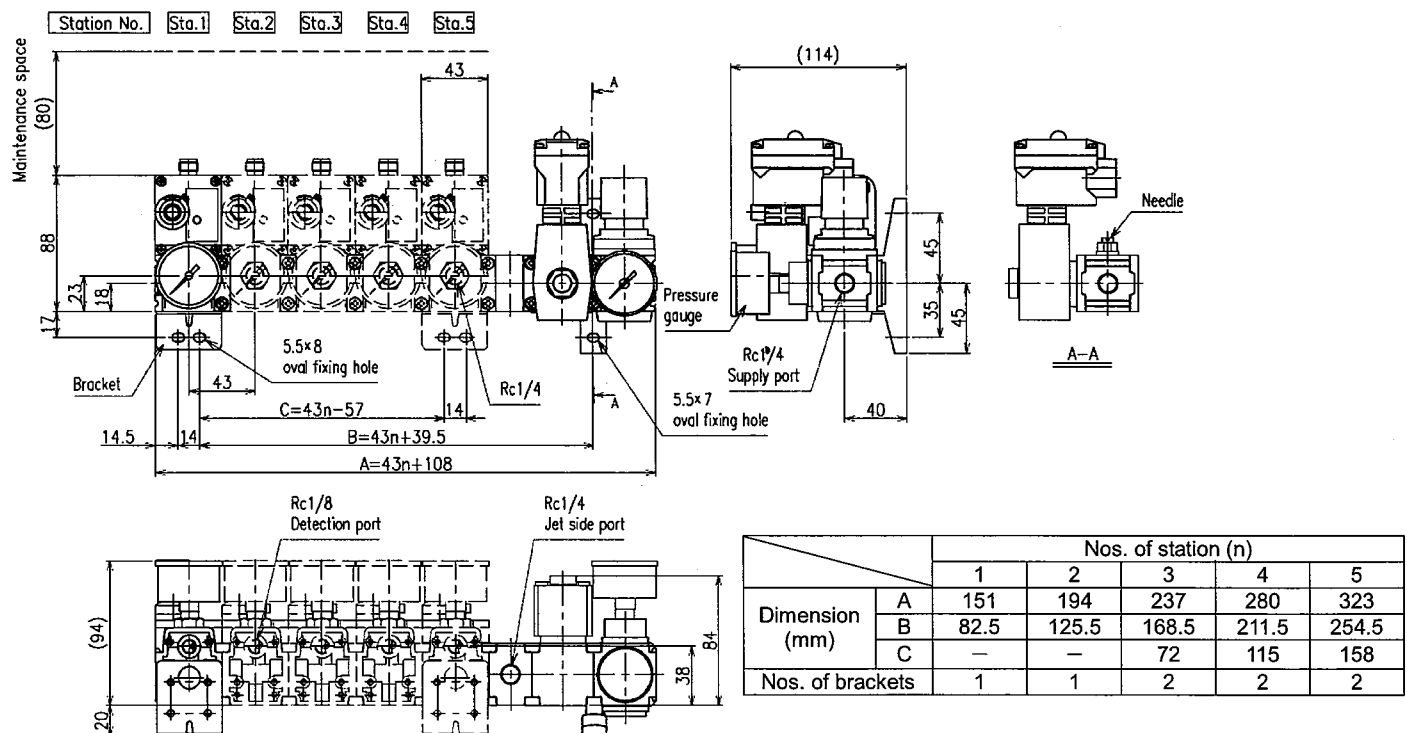

1.2.3.3 M12-connector common terminal box (CTL,CTR)

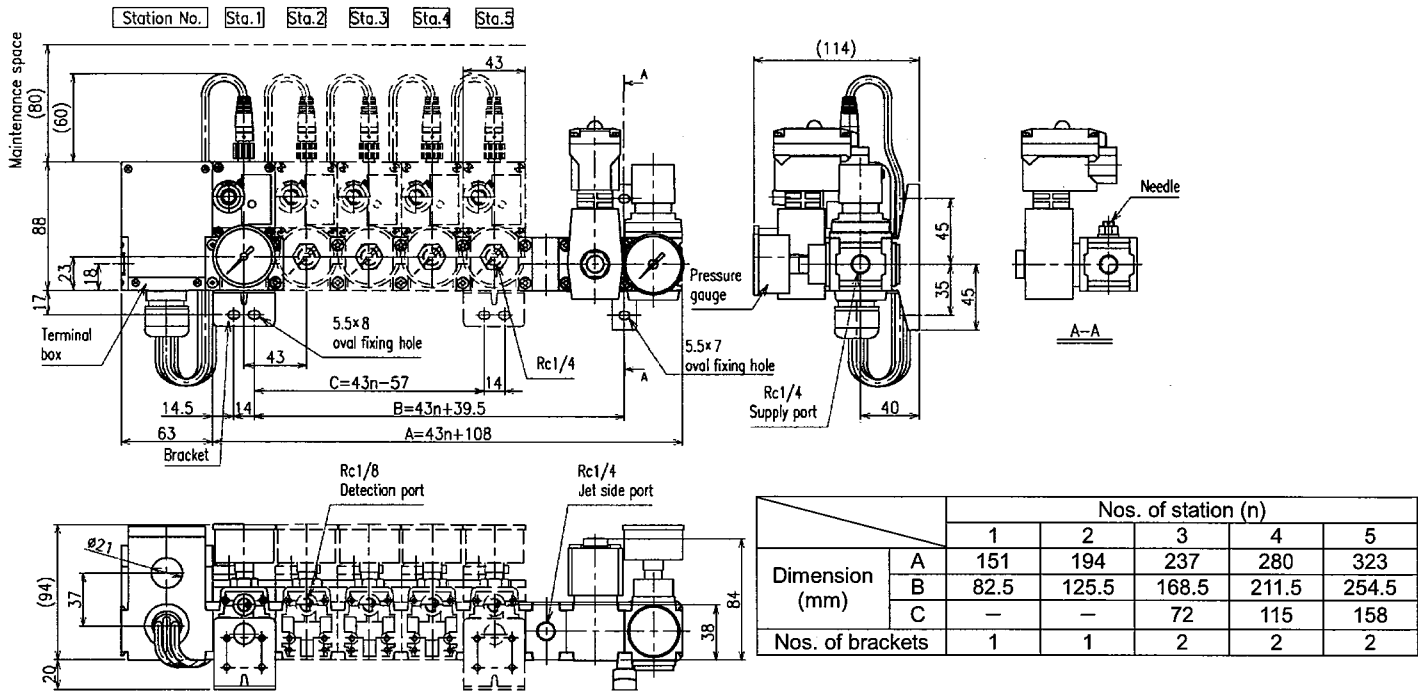

1.2.3.4 Lead wire type common terminal box (TL,TR)

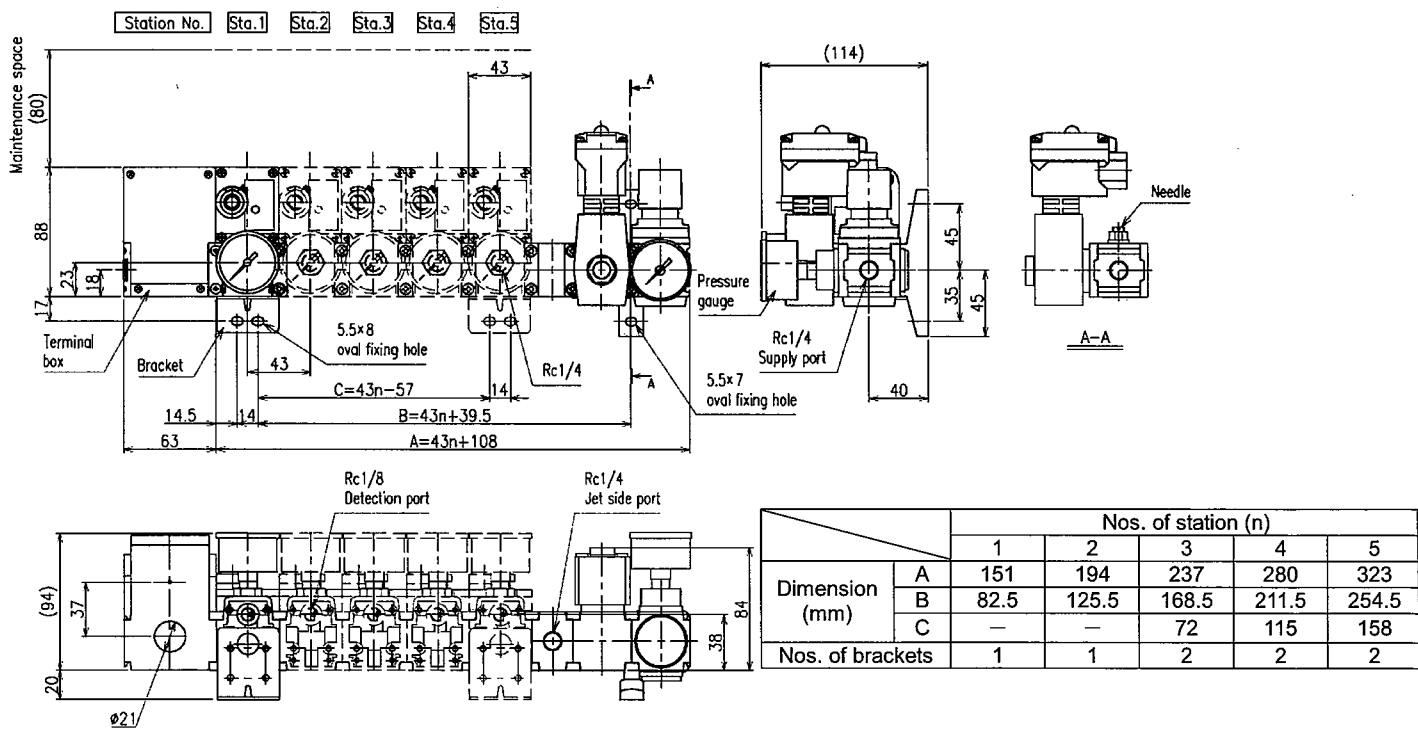



1.2.4 Pair direction nozzle

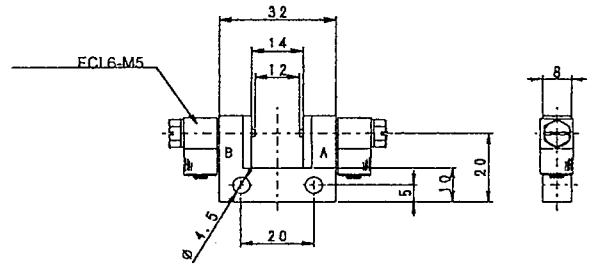
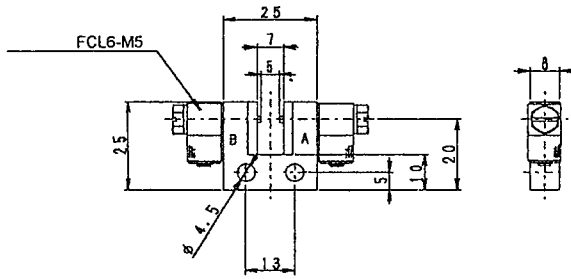
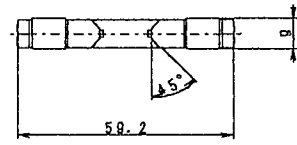
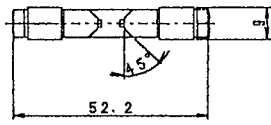

TLPS-J0310

TLPS-J0510

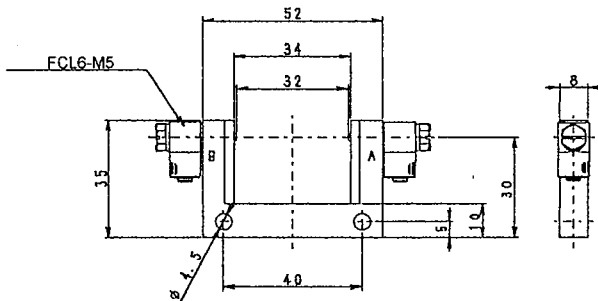
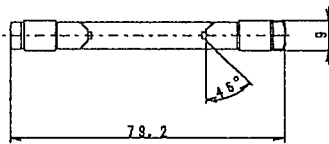

TLPS-J0715

Type	Injection nozzle A	Receive nozzle B
TLPS-J0310	φ 0.3	φ 1.0
TLPS-J0510	φ 0.5	φ 1.0
TLPS-J0715	φ 0.7	φ 1.5

material Body : alminium

Nozlle : SUS303

1.2.5 Option
1.2.5.1 cable

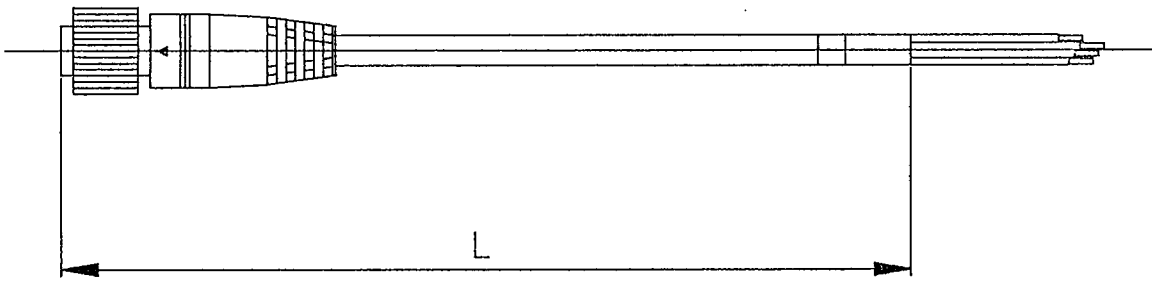

1.2.5.2 Bracket

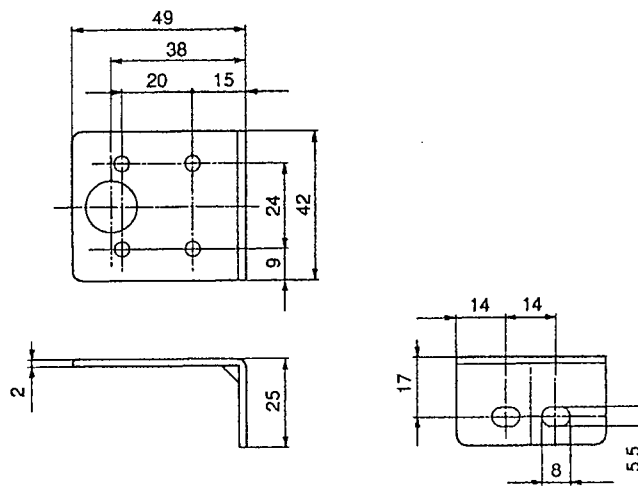

1.2.5.3 Terminal box

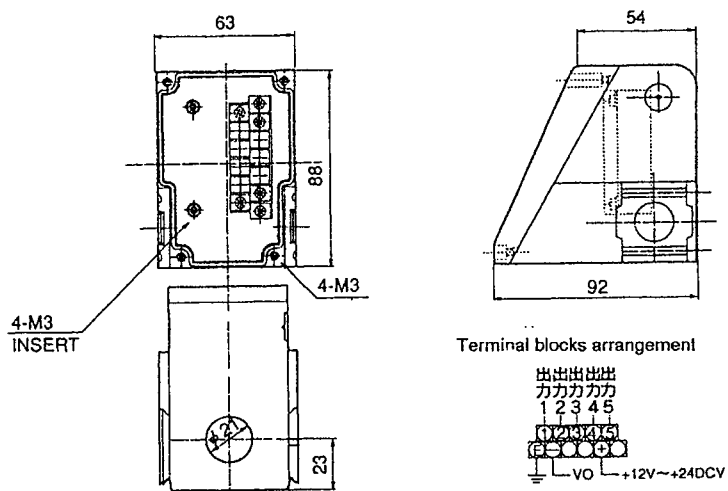



1.2.5.4 Pressure gauge with safety mark

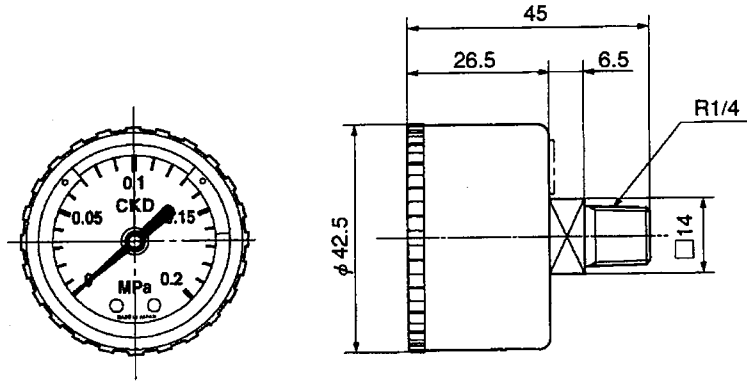

Setup range of safety zone : 0.03~0.2 MPa
 Setup maximum width of safety zone : 0.09 MPa
 Accuracy of gage : JIS B 7505 3 class equivalence
 Material of cover : transparency nylon

1.2.5.5 Joiner

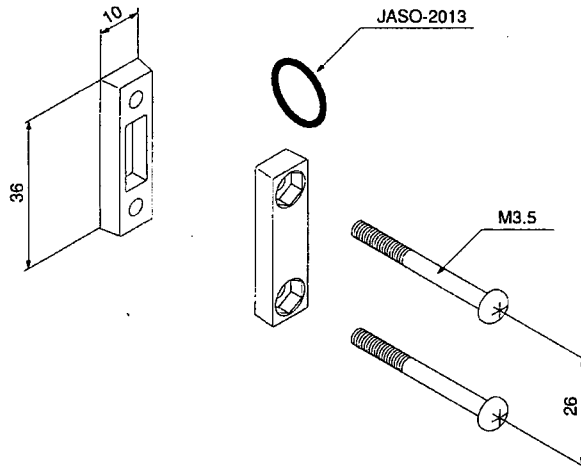

1.2.5.6 T type bracket

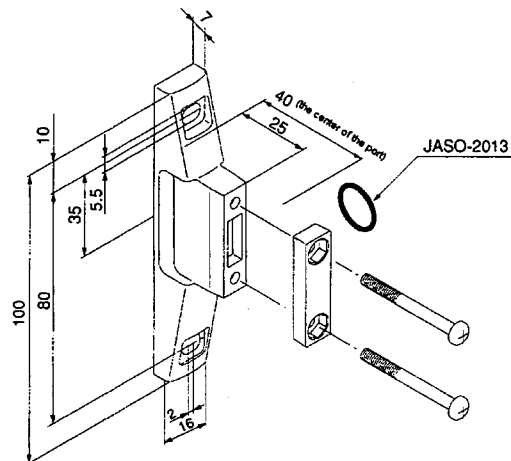

1.2.5.7 Distributer

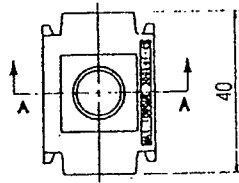

Plane

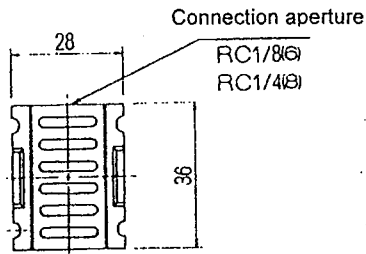

Front

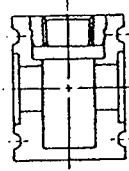

Section A-A

1.2.5.8 Regulator

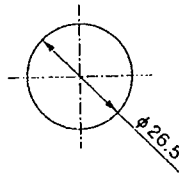
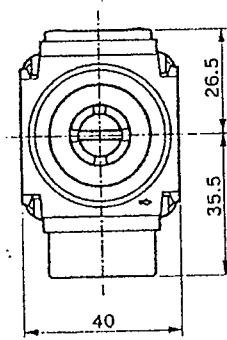

Panel cut dimension
(Panel thickness : Max 6mm)

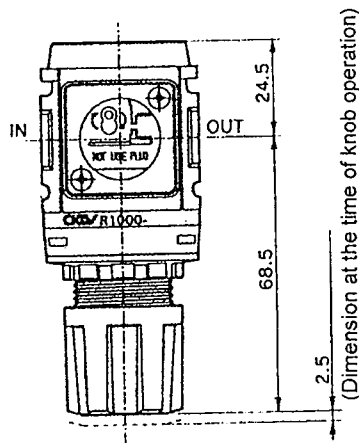

(Dimension at the time of knob operation)

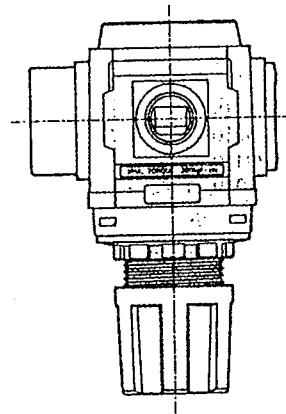



1.2.5.9 Solenoid valve with needle

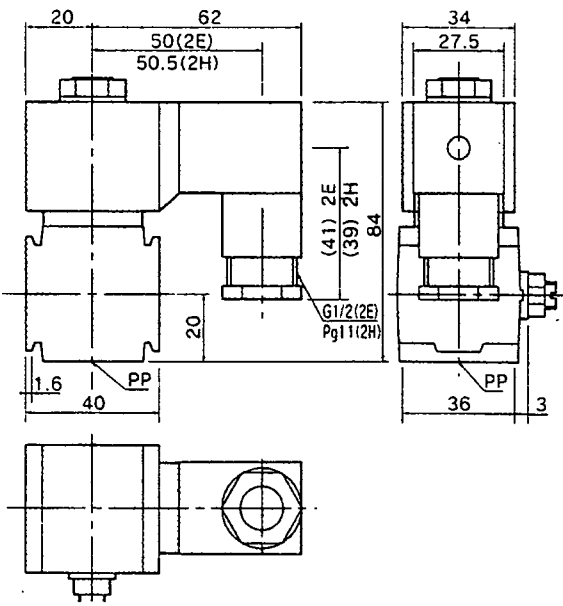

GPS2-AB3X-2E(2H)-AC100V(AC200V)

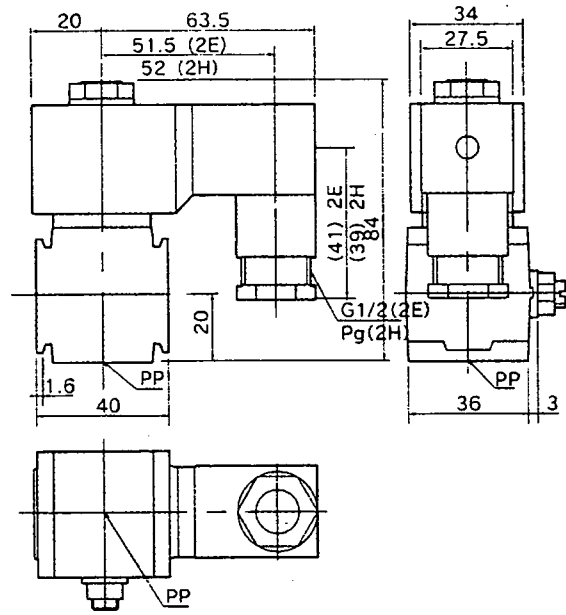

GPS2-AB3X-2E(2H)-DC24V

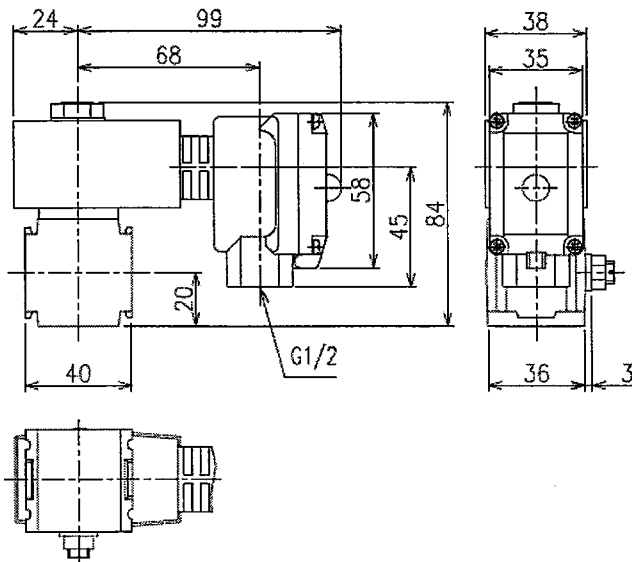

GPS2-AB3X-3N-AC100V(AC200V)

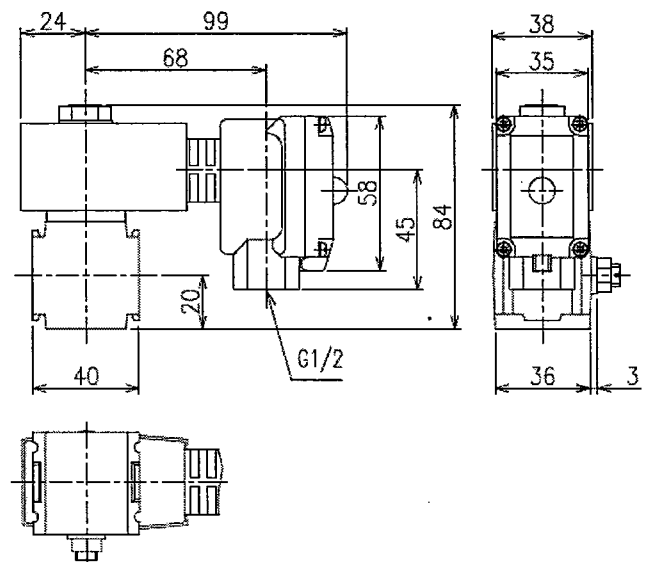

GPS2-AB3X-3N-DC24V



2. CAUTIONS

- 1) Use the product within the ranges permitted by the specifications. If you have to exceed the permitted ranges or use the product for a special purpose, consult us beforehand.
 - Exceeding the permitted ranges will prevent the product from achieving the intended performance and may cause a safety problem.
- 2) Make sure that the product will withstand the service environment.
 - Do not install the Tool switch in an environment that will be harmful to its functions.
 - The Tool switch is made mainly of aluminum and resin. Do not use the Tool switch in an atmosphere that includes a corrosive gas. Avoid using the Tool switch in a special environment such as the following: an environment in which a high temperature may prevail; in presence of chemical vapors or in proximity of chemicals; an environment in which ozone is produced; or an outdoor environment.
- 3) When designing the pneumatic circuit, pay attention to the particular requirements for the smooth flow of compressed air.
 - The Tool switch includes a small orifice. To prevent the orifice from being blocked by foreign matter or chips in the cutting fluid, supply clean air through the basic air-circuit given in Fig. 1 .

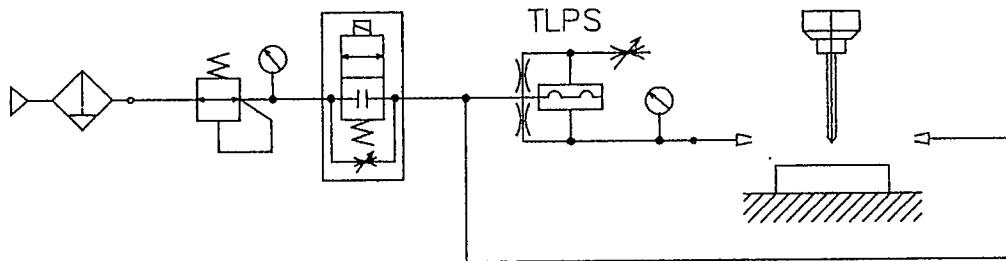

Filter : 5 μ m or less

Regulator : low pressure use

Solenoid valve with needle : GPS2-AB3X-□-FL-□ (2-way valve only)

Figure 1 basic air-circuit

- 4) The mixture of compressor oil or tar-like substances may block the air flow and cause a malfunction. Periodically inspect the compressor and discharge the drain.
- 5) To prevent the reverse flow of the cutting fluid or oil from the detection nozzle, maintain a constant flow of the air or supply a minute flow of air from the bypass circuit using a solenoid valve with a needle as in the Fig. 1 .
- 6) Avoid injecting cutting fluid directly between the opposed nozzles. Also, detection during machining gives rise to nozzle damage due to chips. Detection at the drill retract end is always required.
- 7) Cutting or grinder chips may block the nozzle. An increase in the supply pressure will not be able to blow the chips off because the internal orifice will choke the flow. To enable the blow-off, install a 3-way valve to the detection port side as in Fig. 2. The orifice of the 3-way valve has to be 2.5 mm or larger in diameter.

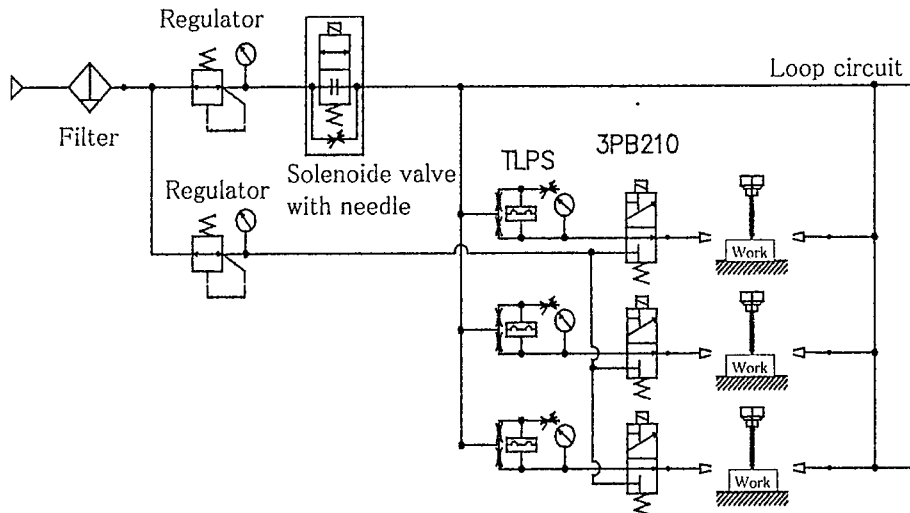

Figure 2 Using 3-way valve for blow

- 8) The piping used should be 4 mm in inside diameter and 6 mm in outside diameter. Also, where a 3-, 4- or 5-way valve is used, make arrangements so that each nozzle injection amount is as uniform as possible. The branching method is as shown in Fig. 2 above: form the loop circuit with this piping 8 mm in outside diameter and 6 mm in inside diameter.
- 9) Select a HPS with an output style (NPN or PNP) that is compatible with the input unit of your programmable controller.
- 10) The signals of TLPS are as follows:

Drill Status	Drill provided	No drill provided
Air stop	Lamp-OFF / output OFF	Lamp-OFF / output OFF
Air supply	Lamp-OFF / output OFF	Lamp-ON/ output ON

Basic circuit (Fig. 1): Where a solenoid valve with needle is used, air is gentle, but air is constantly to be supplied. Even when the solenoid valve with needle is OFF, TLPS may work in the air supply state.

- 11) The recommendable supply pressure in using the standard opposed nozzles is 100 kPa. Where the standard nozzle detection width 32 mm is exceeded, contact us concerning the opposed nozzle profile and pneumatic circuit.
- 12) – When letting air flow only during detection:
The time for letting air flow should be 2 seconds Min. Also, avoid fetching any signal for the stable time 1 second after solenoid valve release. One second left is the judgement time, and when the drill is normal, the signal is OFF.
– When letting air flow continuously:
The response time differs, depending on the piping length and supply pressure, which is approx. 0.2 sec. However, the standard dwell time should be 0.5 second.



- 13) If a capacitive load such as a buzzer is connected to the load, an unintended action of the output protection circuit may interfere with the normal operation. When designing the load, consider not only the rated current but also the transient current value.

TLPS Time chart

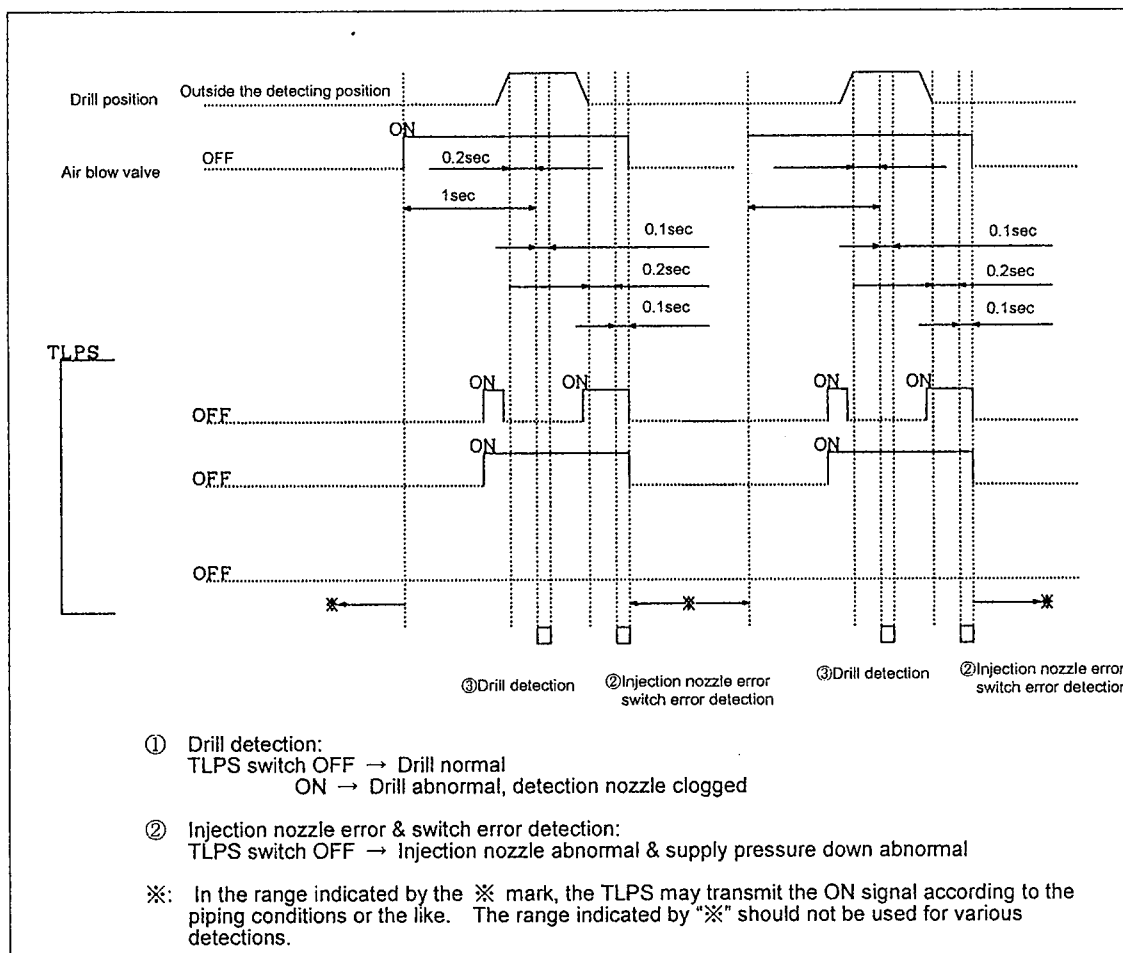

3. Operation

3.1 Adjustment

3.1.1 Adjustment procedure for cutting edge detection

- 1) The adjusting needle is factory adjusted to "0" in revolution and "0" in rotation angle before shipment.
- 2) Supply air. The indicator lamp is turned OFF (goes out).
- 3) In the drill-less state, turn the adjusting needle in the direction in which this knob rotation value increases (open) to find point A where "OFF" changes to "ON".
- 4) Insert the drill tip 1 mm into the nozzle part (OFF-state), and further turn it in the direction in which the value increases (open) to find point B' where "OFF" changes to "ON".
 - Where the tip 1 mm was exceeded or the standard nozzle was used, point B' may not be found. In that case, go forward a half turn (50 scales) from point A to get the setting point C.
- 5) Turn it in the direction in which the revolution decreases (close) to find point B where "ON" changes to "OFF".
By counting the revolutions at point B from point A, the adjustment range will be known.
- 6) Turn the adjusting needle in the closed direction to set it to the mid point between points A and B. This position should be point C.
 - If the position at point C is near to point C, the signal will be readily turned ON, and the response time is quick, while resetting is time-consuming. If adjusting point C is provided in the middle position between points A and B, stable detection will be carried out.
- 7) After completion of this adjustment, locking is required.

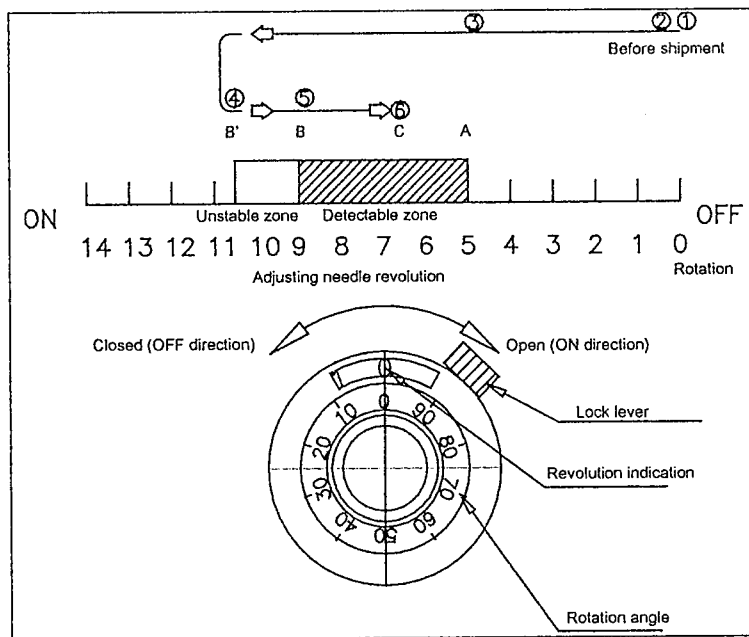

Adjusting Needle Knob

- Do not turn the knob unnecessarily at both ends of revolutions. The maximum revolutions are approx. 10 to 14.

3.1.2 Simplified adjustment

No	Nozzle Unit Type No.	Distance between Nozzles	Applicable Drill Diameter	Standard Needle Revolutions
1	TLPS-J0310	5mm	φ 0.3-3	1.8-2.2rotations
2	TLPS-J0510	12mm	φ 1-10	2.3-2.7rotations
3	TLPS-J0715	32mm	φ 3-30	5.3-5.7rotations

NOTE: The revolutions are only for reference at supply pressure 100 kPa and pipe length 5 m.

3.2 Notes on Use

- 1) If the adjustment dial receives a shock from being knocked, dropped, or hit, the marks on the dial will not indicate the correct detection distances any more. Handle carefully.
- 2) Use a single tool switch for each detection nozzle.
- 3) For a short time after the startup, the switch will remain ON due to the presence, in the piping, of the cutting fluid that entered from the nozzle. Start the machine only after the cutting fluid has been drained by the detection air.
- 4) If the nozzle is blocked, the needle of the monitor pressure gage will point to a high pressure value and will not return to zero. Disconnect the gap switch side piping and blow off the foreign matter using compressed air. If it does not work, insert a needle into the detection nozzle end.
- 5) When the cutter break detecting switch signal ON or OFF is continuously transmitted, regard this phenomenon as abnormal.
The error signal is as shown in the table below.

Status	Continuously OFF	Continuously ON
Cause	<ul style="list-style-type: none"> • No air • Maladjustment • Clogged injection nozzle • Leakage from piping • Wire disconnection • Internal circuit failure 	<ul style="list-style-type: none"> • Cutter break detection • Malfunction • Clogged pressure nozzle • Pipe break & bend • Internal circuit failure

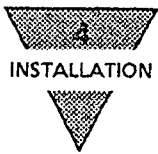

4. Installation

4.1 Installation

The bracket has two different bolt hole positions: one for the mounting of the tool switch with its rear panel facing the wall, another for the mounting via a T-type bracket.

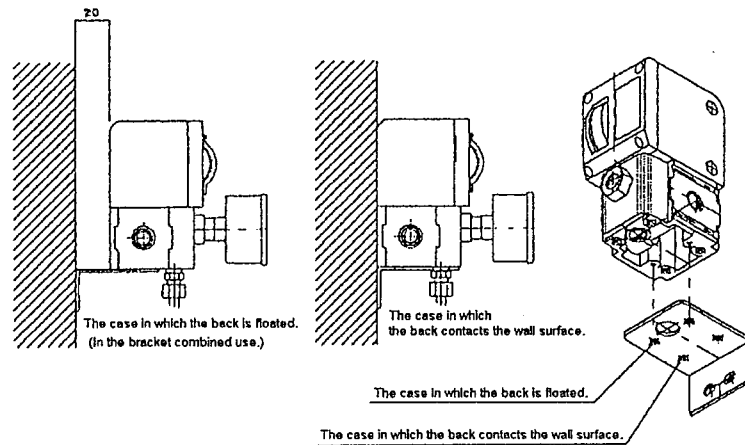

Figure 3

- Please install it as the detection port of TLPS becomes downward.
- To prevent the penetration of cutting fluid, install the tool switch at a level higher than the seating face.
- Provide enough space for adjustment, monitoring, and holding.
- Choose rust-proof piping materials such as nylon and stainless tubes.
- Before connecting a tube, remove foreign matter and cutting chips from the inside of the tube by blowing air into it.
- When connecting a device or tube, pay attention not to allow the entry of a piece of seal tape or adhesive into the circuit.
- When mounting a device to the tool switch, do not allow the weight of the device to be held by the tool switch.
- If the tool switch is connected with a metal tube, the tube has to be fixed firmly at its position. Otherwise an excessive amount of stress may arise at the connecting portion.
- Do not apply a shock to the tool switch by a hitting or knocking it.
- If you have to perform a welding operation nearby, cover the tool switch to protect it against the spatters.
- If you install the tool switch inside a box, be sure to provide a ventilation hole so that the pressure inside the box may remain the same as the barometric pressure. A rise in the internal pressure may cause a malfunction.

4.1.1 M-12 connector type

A connector can easily be disconnected by loosening the nut at the cable end. This feature allows speedy mounting and dismounting of individual tool switches.

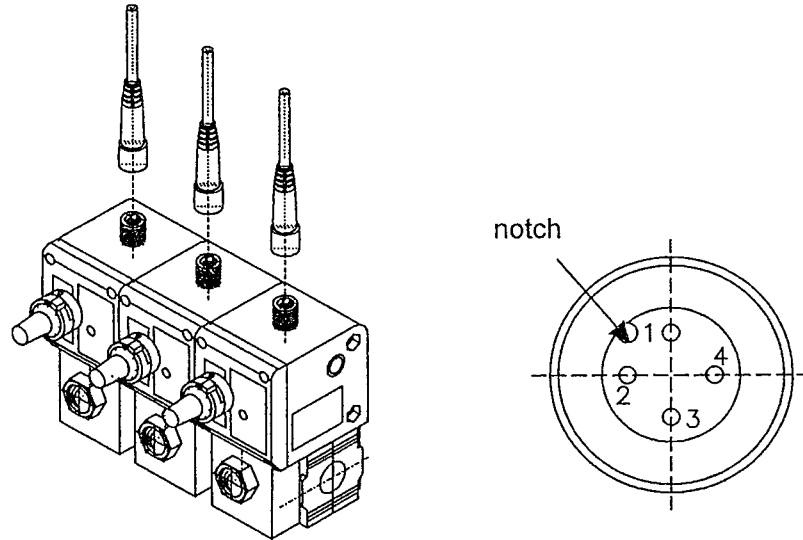

Figure 4 Disassembling M-12 connector cable

4.1.2 DIN-terminal type

After you remove the M3 screw at the top, the unit is split into a plug and a socket. This type of terminal requires a certain amount of work in the beginning for the wiring but enables speedy replacement of the tool switch afterward.

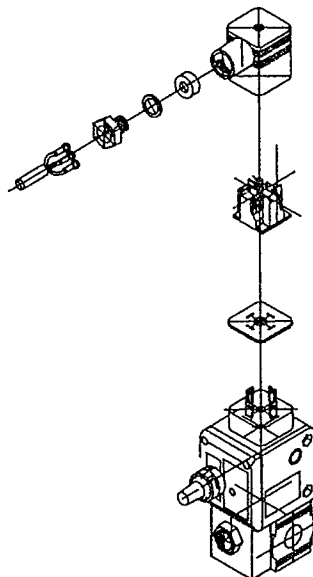

Figure 5 Disassembling DIN-terminal socket

4.2 Wiring

4.2.1 M-12 connector type , wiring option (C*)

In case of wiring to M-12 connector type, refer to the following figure.

Pin arrangement (TLPS main body side)

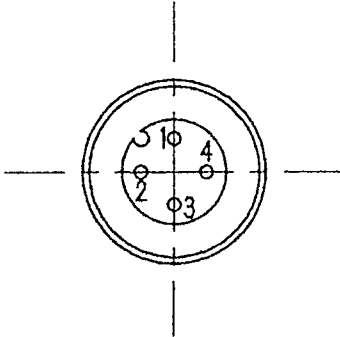

Figure 6

Pin No.	Wiring option (-C1,-C3,-C5) Lead wire color	Use
1	Brown	Power supply (+)
2	White	N.C. (no use)
3	Blue	Power supply (-)
4	Black	Output

4.2.2 DIN-terminal type

Pin arrangement (TLPS main body side)

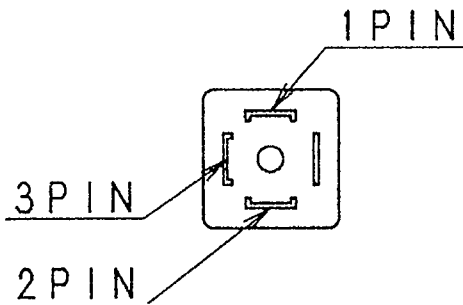

Figure 7

Pin No.	Use
1	Power supply (+)
2	Power supply (-)
3	Output

4.2.3 Common terminal box type

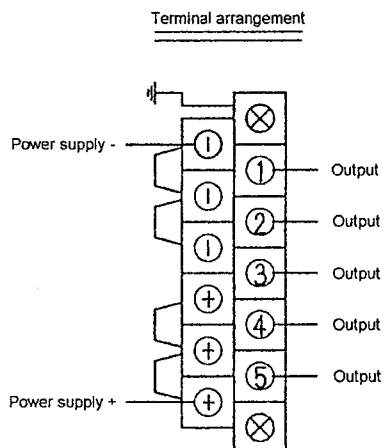
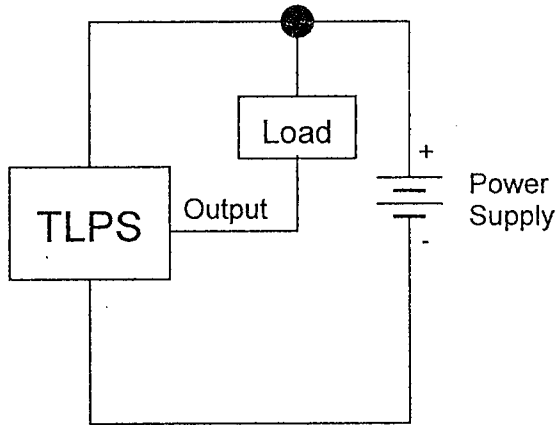

Figure 8

4.2.4 Notes on wiring

- 1) Tool switches come with two different output types: NPN open collector type and PNP open collector type. If you chose the wrong output type, the input unit will not be able to receive signals even though the internal lamps will function normally. We recommend our customers carefully choose tool switches of an output type compatible with the input unit in use.



Connection method of NPN open collector

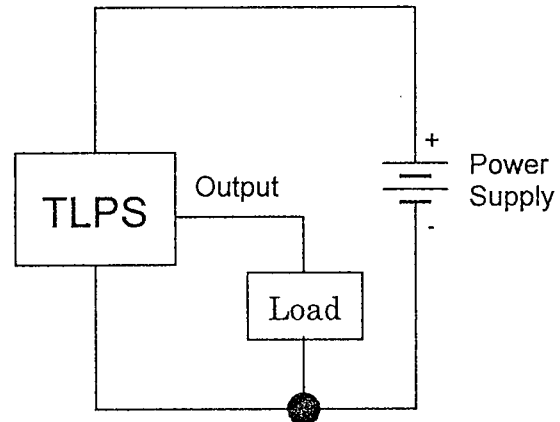

Connection method of PNP open collector

- 2) The presence of a motor or power cable in proximity of the tool switch wires may cause the sensor element in the tool switch to deteriorate or fail due to surges and noise. Be sure to separate the cables.
- 3) If a source of a major surge current (a motor or welder, for example) is present near the tool switch, install a surge killer close to the source.
- 4) A mistake in the wiring may cause damage to the internal circuit. Take care not to make a mistake in the wiring.
- 5) If an excessive current is caused by a short circuit in the load, for example, the protection circuit will trip. To restart, turn the power OFF and then ON. Note, however, that you have to find and remove the cause of the trip before turning the power ON.
- 6) Do not use the tool switch immediately after the startup while it is still in a transient state.
- 7) If you use a switching regulator in the power supply, be sure to provide a FG (frame ground) terminal.

5. MAINTENANCE

5.1 Manifold Installation

● Lead wire type common terminal box type

A lead wire goes through the tool switch. Before you order a tool switch for additional installation or replacement, take note of the wire lead-out port. During the replacement, you have to temporarily remove the front cover of the tool switch to allow insertion of the lead wire to the next tool switch. The lead wire insertion hole accommodates a cylindrical packing. Insert the lead wire through the packing before assembling the next terminal box. Adjoining tool switches and terminal boxes are connected using joiners. Be sure to insert an O-ring between the air supply ports before securing the joiners.

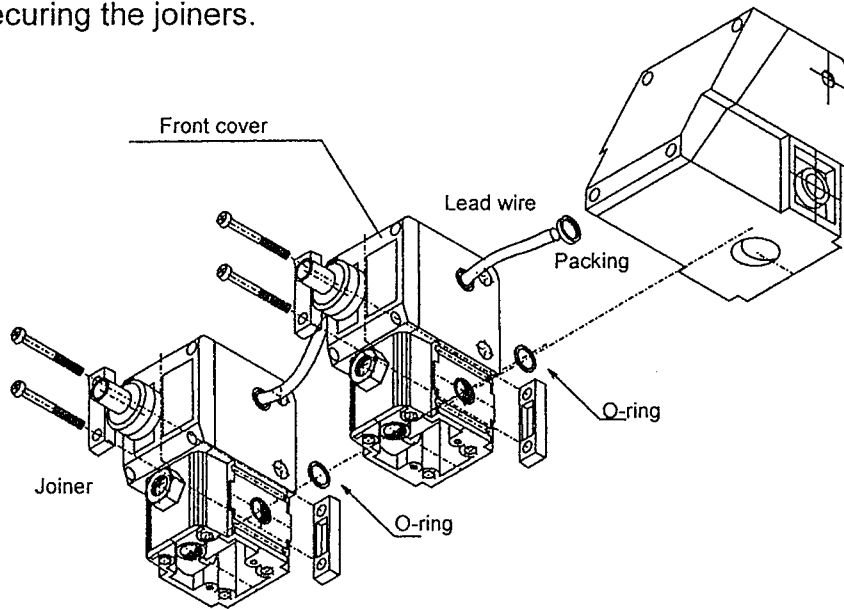

Figure 9 Assembling lead wire common terminal box type

5.2 Disassembly

Replaceable items inside the tool switch are the proximity switch and diaphragm. Note that the front cover is irreplaceable because its replacement will affect performance. Penetration of dust or oil during disassembly may decrease the performance. Since small O-rings are used, work in a clean environment instead of working at the site.

5.2.1 Proximity switch

- 1) Remove four M3 screws on the front cover. When the front cover is removed, you will see a proximity switch inside the body. Never apply a shock to the removed front cover by dropping or hitting it; the performance will be affected if you do. You will find packing between the front cover and body. Do not lose it.
- 2) The proximity switch is connected using a small connector made of resin. Pull the connector until it comes out of the body and then disconnect it.

- 3) Remove two screws fixing the proximity switch. Replace the used proximity switch with a new one. Secure the new proximity switch at a position where its end makes a full contact with the bottom surface of the body.
- 4) Connect the resin connector, supply the electrical power, and test the operation of the proximity switch. If the switch is confirmed to be OFF at this time, install the front cover.
- 5) With the air supplied, make sure that blocking the detection port turns the tool switch ON.

5.2.2 Diaphragm

- 1) Four screws at the bottom of the aluminum body secure the resin body. When you split the bodies vertically, you will find between them a diaphragm over a restriction plate. You will find an O-ring at a different location.
- 2) After removing the used diaphragm, place the restriction plate on the aluminum body. The restriction plate fits into a recess in the body.
- 3) Place a new diaphragm over the restriction plate while making sure that an iron piece molded to the diaphragm faces the aluminum body. Take care not to set the diaphragm off the center.
- 4) Attach the O-ring used for sealing the ventilation holes in the upper and lower bodies. Then assemble the upper and lower bodies using the four screws.
- 5) With the air supplied, make sure that blocking the detection port turns the tool switch ON.

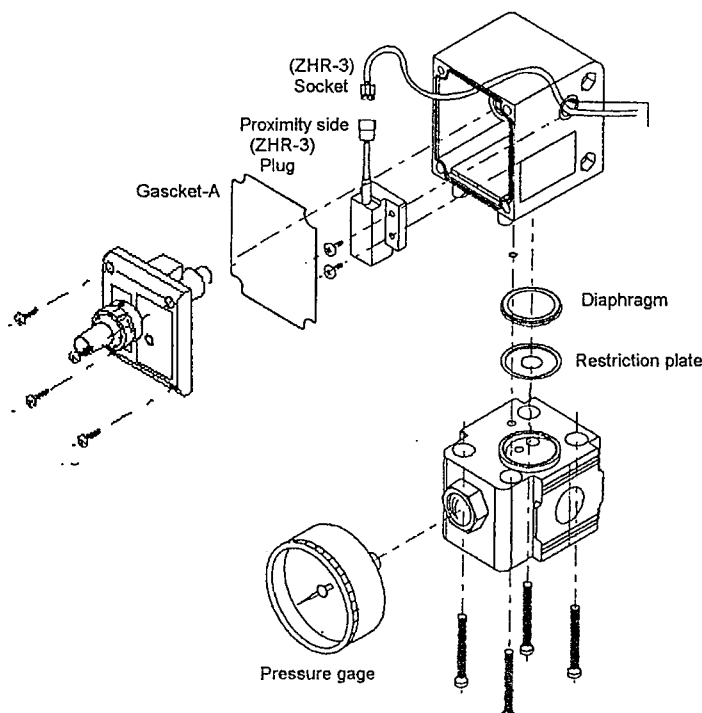
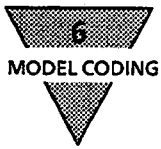

Figure 10



6. Model code

6.1 Single type

TLPS - 03 - **I** Y **II** - **III** - **IV**

I	Type of output
N	NPN open collector
P	PNP open collector
II	Wiring option
F	DIN-terminal
C0	M-12 connector (cable : none)
C1	M-12 connector (1m cable : attached)
C3	M-12 connector (3m cable : attached)
C5	M-12 connector (5m cable : attached)
CTL	Assembled M-12 connector type common terminal box at the left side
CTR	Assembled M-12 connector type common terminal box at the right side
TL	Assembled lead wire type common terminal box at the left side
TR	Assembled lead wire type common terminal box at the right side
	Goods for the common terminal box
R	For the left assembling
L	For the right assembling
W	For the middle assembling
III	Attachment , others
No code	Bracket : none
B	Bracket : attached
IV	Pressure gauge
No code	Pressure gauge : none
G2	Pressure gauge with safety mark : attached
GW2	Pressure gauge with safety mark : assembled

6.2 Manifold type

MTLPS - 03 - I II Y III - IV - V

I Nos. of station	
2	2 stations
3	3 stations
4	4 stations
5	5 stations

II Type of output	
N	NPN open collector
P	PNP open collector

III Wiring option	
F	DIN-terminal
C0	M-12 connector (cable : none)
C1	M-12 connector (1m cable : attached)
C3	M-12 connector (3m cable : attached)
C5	M-12 connector (5m cable : attached)
CTL	Assembled M-12 connector type common terminal box at the left side
CTR	Assembled M-12 connector type common terminal box at the right side
TL	Assembled lead wire type common terminal box at the left side
TR	Assembled lead wire type common terminal box at the right side
T1	Assembled lead wire type common terminal box between 1 st and 2 nd unit from the left
T2	Assembled lead wire type common terminal box between 2 nd and 3 rd unit from the left
T3	Assembled lead wire type common terminal box between 3 rd and 4 th unit from the left
T4	Assembled lead wire type common terminal box between 4 th and 5 th unit from the left

IV Attachment , others	
No code	Bracket : none
B	Bracket : attached

V Pressure gauge	
No code	Pressure gauge : none
G2	Pressure gauge with safety mark : attached
GW2	Pressure gauge with safety mark : assembled

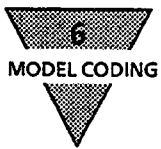

6.3 Unit type

UTLPS - 03 - **I** **II** Y **III** - **IV** - **V** - **VI** - **VII**

I Nos. of station	
1	1 station
2	2 stations
3	3 stations
4	4 stations
5	5 stations
II Type of output	
N	NPN open collector
P	PNP open collector
III Wiring option	
F	DIN-terminal
C0	M-12 connector (cable : none)
C1	M-12 connector (1m cable : attached)
C3	M-12 connector (3m cable : attached)
C5	M-12 connector (5m cable : attached)
TL	Assembled lead wire type common terminal box at the left side
TR	Assembled lead wire type common terminal box at the right side
CTL	Assembled M-12 connector type common terminal box at the left side
CTR	Assembled M-12 connector type common terminal box at the right side
IV Attachment , others	
B	Bracket : attached
V Pressure gauge	
No code	Pressure gauge : none
GW2	Pressure gauge with safety mark : assembled
VI Solenoid valve connecting type (note)	
2E	DIN terminal box
2H	DIN terminal box with lamp
3N	HP terminal box with lamp
VII Solenoid valve voltage	
1	AC100V
2	AC200V
3	DC24V

note) The products for CE Marking please select solenoid valve connecting type "2E" "2H" .

6.4 Pair direction nozzle

TLPS – J I

I Nozzle diameter	
0310	Injection nozzle : ϕ 0.3 , Receive nozzle : ϕ 1.0
0510	Injection nozzle : ϕ 0.5 , Receive nozzle : ϕ 1.0
0715	Injection nozzle : ϕ 0.7 , Receive nozzle : ϕ 1.5

6.5 Option

6.5.1 Cable

GPS2 – I

I cable length	
C1	1m
C3	3m
C5	5m

6.5.2 Bracket

GPS2 – B

6.5.3 Terminal box

GPS2 – I

I Terminal box	
CTL	For assembling M-12 connector type common terminal box at the left side
CTR	For assembling M-12 connector type common terminal box at the right side
TL	For assembling lead wire type common terminal box at the left side
TR	For assembling lead wire type common terminal box at the right side
TW	For assembling lead wire type common terminal box at the middle

6.5.4 Pressure gauge with safety mark

G40D – 8 – I – S501

I Range	
P02	0~0.2MPa
P04	0~0.4MPa
P10	0~1.0MPa

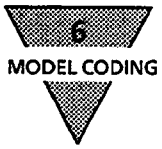

6.5.5 Joiner set

C1000 – J100 – W

6.5.6 T type bracket set

B110 – W

6.5.7 Distributor

D101 – 00 – 8 – W

6.5.8 Adapter sets for 2 pipe arrangement (attached with joiner set)

A100 - I – W

I Port size	
8	Rc 1/4
10	Rc 3/8

6.5.9 Adapter set for pipe arrangement (attached with T type bracket set)

A100 - I – W – B11W

I Port size	
8	Rc 1/4
10	Rc 3/8

6.5.10 Solenoid valve with needle

GPS2 - AB3X - I - FL - II

I Solenoid valve connecting type	
2E	DIN terminal box
2H	DIN terminal box with lamp
3N	HP terminal box with lamp

II Solenoid valve voltage	
AC100V	
AC200V	
DC24V	

6.5.11 Regulator

R1000 – 8 – W – LT