

The ACE gas spring range includes push type and pull type (traction) gas springs all designed for the industrial environment.

**ACE industrial gas springs** are maintenance-free and self-contained. They are available with body diameters from 8 mm up to 70 mm, and forces from 10 N up to 13 000 N ex. stock. **ACE gas springs offer a high service life with a hard ceramic coating on the piston rod. Also an integrated low friction bearing with grease chamber which provides a very low break away force (GS-15 to GS-40).** It allows them to be mounted in any orientation, although rod downwards is preferable if you want to take advantage of the built-in end position damping. The valve allows the force to be adjusted to your specific requirements. A wide variety of interchangeable end fittings makes installation easy and versatile. ACE gas springs are universally applicable wherever you have lifting and lowering. They remove the need for "muscle power" and provide controlled motion for lids, hoods, machine guards etc. The ACE selection software quickly specifies the correct gas spring for your individual application and we can deliver, usually within 24 hours. **ACE traction gas springs** work in pull direction and are available with body diameters of 19 mm and 28 mm.

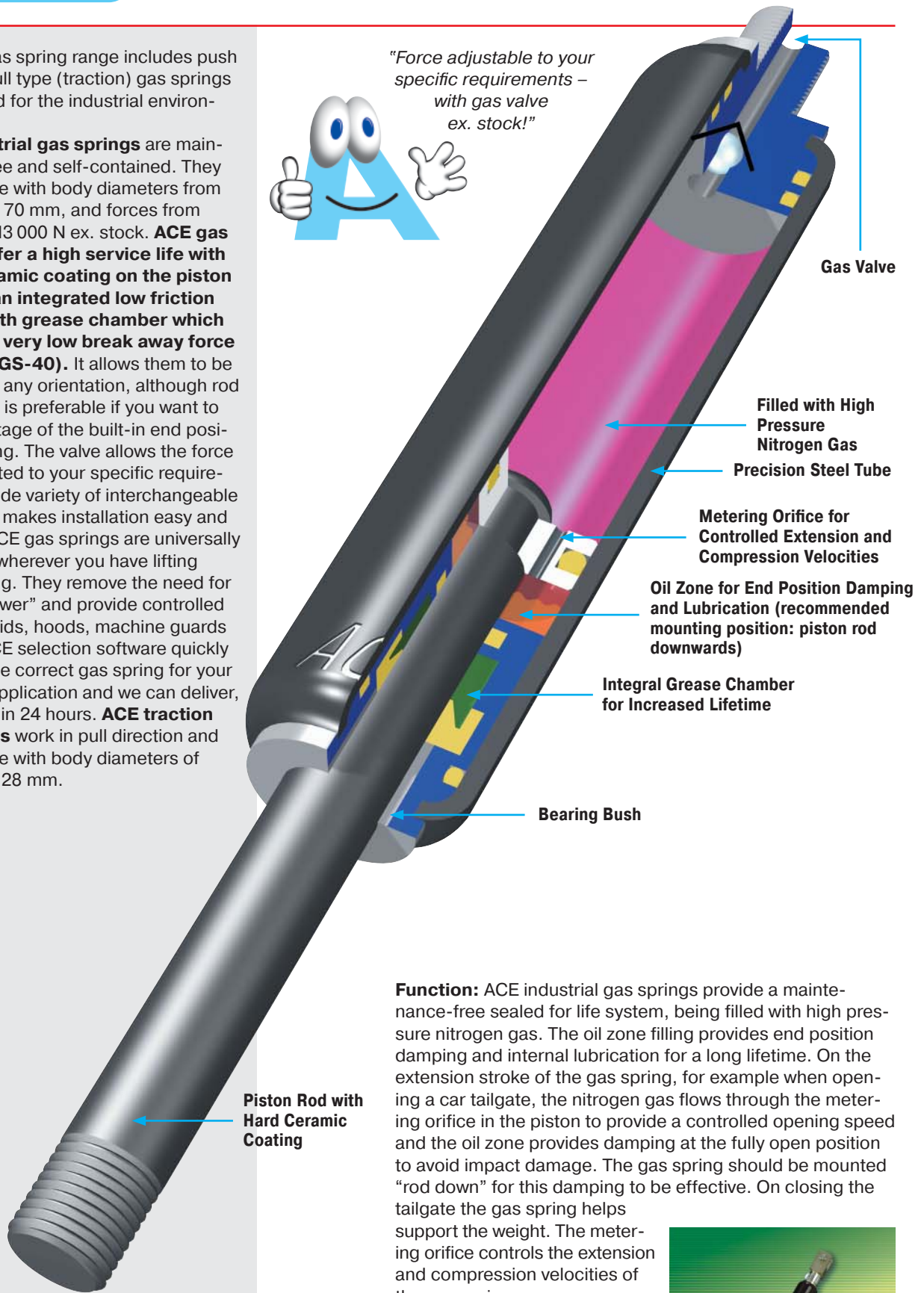

*"Force adjustable to your specific requirements – with gas valve ex. stock!"*



Gas Valve

Filled with High Pressure Nitrogen Gas  
Precision Steel Tube

Metering Orifice for Controlled Extension and Compression Velocities

Oil Zone for End Position Damping and Lubrication (recommended mounting position: piston rod downwards)

Integral Grease Chamber for Increased Lifetime

Bearing Bush

Piston Rod with Hard Ceramic Coating

**Function:** ACE industrial gas springs provide a maintenance-free sealed for life system, being filled with high pressure nitrogen gas. The oil zone filling provides end position damping and internal lubrication for a long lifetime. On the extension stroke of the gas spring, for example when opening a car tailgate, the nitrogen gas flows through the metering orifice in the piston to provide a controlled opening speed and the oil zone provides damping at the fully open position to avoid impact damage. The gas spring should be mounted "rod down" for this damping to be effective. On closing the tailgate the gas spring helps support the weight. The metering orifice controls the extension and compression velocities of the gas spring.

**Operating fluid:** Nitrogen gas and oil (for end damping)

**Mounting:** In any position

**Operating temperature range:** -20 °C to 80 °C

**On request:** Without damping, extended length damping, special force curves, special lengths, alternative end fittings.



Issue 4.2009 Specifications subject to change

**Gas springs are universally accepted**, wherever you want to **push, pull, lift, lower, or position** covers, lids or other components by hand without using an external energy source.

**ACE gas springs** are individually filled to a predetermined pressure to suit a customer's requirement (extension Force  $F_1$ ). The cross-sectional area of the piston rod and filling pressure determines the extension force  $F = p \cdot A$ . During the compression of the piston rod, nitrogen flows through an

orifice in the piston from the full bore side of the piston to the annulus. The nitrogen is compressed by the volume of the piston rod. As the piston rod is compressed the pressure increases, so increasing the reaction force (progression). The force depends on the proportional relationship between the piston rod and the inner tube diameter, which is approximately linear.

### Gas Spring Force-Stroke Characteristics

#### Standard Gas Spring (Push Type)

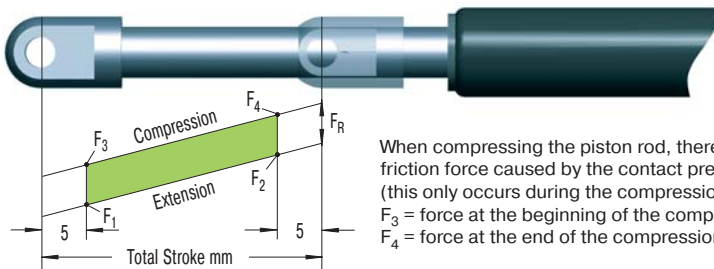

When compressing the piston rod, there is an additional friction force caused by the contact pressure of the seals (this only occurs during the compression stroke)  $F_R$   
 $F_3$  = force at the beginning of the compression stroke  
 $F_4$  = force at the end of the compression stroke

$F_1$  = nominal force at 20 °C (this is the pressure figure normally used when specifying the gas spring)

$F_2$  = force in the complete compressed position

#### Traction Gas Spring (Pull Type)

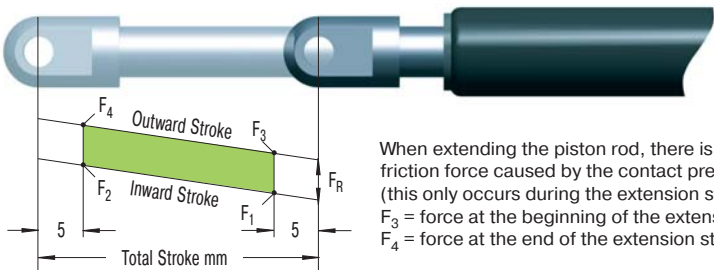

When extending the piston rod, there is an additional friction force caused by the contact pressure of the seals (this only occurs during the extension stroke)  $F_R$   
 $F_3$  = force at the beginning of the extension stroke  
 $F_4$  = force at the end of the extension stroke

$F_1$  = nominal force at 20 °C (this is the pressure figure normally used when specifying the gas spring)

$F_2$  = force in the complete extended position

Type	<sup>1</sup> Progression approx. %	<sup>2</sup> Friction $F_R$ approx. in N
GS-8	28	10
GS-10	20	10
GS-12	25	20
GS-15	27	20
GS-19	36 - 42 <sup>3</sup>	30
GS-22	39 - 50 <sup>3</sup>	30
GS-28	60 - 95 <sup>3</sup>	40
GS-40	47 - 53 <sup>3</sup>	50
GS-70	25	50

Type	<sup>1</sup> Progression approx. %	<sup>2</sup> Friction $F_R$ approx. in N
GZ-19	10	20 - 40
GZ-28	20	100 - 200

<sup>1</sup> **The progression** (the slope of the force line in the diagrams above) is due to the reduction of the internal gas volume as the piston rod moves from its initial position to its fully stroked position. The approx. progression values given above for standard springs can be altered on request.

**Effect of temperature:** The nominal  $F_1$  figure is given at 20 °C. An increase of 10 °C will increase force by 3.4%.

**Filling tolerance on  $F_1$  force:** -20 N to +40 N or 5% to 7%

<sup>2</sup> Depending on the filling force.

<sup>3</sup> Depending on the stroke.

### Service Life

**Filling tolerance:** -20 N to +40 N or 5 % to 7 %

**Effect of temperature:** An increase in temperature of each 10 °C will increase force by approx. 3.4 %.

**Temperature range:** -20 °C to +80 °C (special seals from -45 °C to 200 °C)

**Mounting:** The gas springs should ideally be installed with the **piston rod pointing downwards** to use the end damping during the extension stroke to smoothly decelerate the motion of the gas spring. Some ACE gas springs have a uniquely designed front bearing with an integrated grease chamber allowing the gas spring to be mounted and operated in any position if required.

**When fitting the gas springs ensure that the stroke is fully extended (GZ type fully compressed)**, this makes assembly and disassembly much easier. **Support the moving mass/flap during assembly or disassembly to prevent accidents. To avoid twisting or side loading, it is recommended that ball joints or other pivoted mounting attachments are used.** The mounting attachments must always be securely tightened onto the threaded studs of the gas spring.

ACE gas springs are maintenance-free. DO NOT oil or grease the piston rod!

The piston rod must be protected from any hits, scratches or dirt and especially paint. Damage to the surface finish of the piston rod will destroy the sealing system and cause loss of pressure. The outer body must not be deformed or mechanically damaged.

ACE gas springs can be stored in any position. Experience has shown that long storage periods do not result in loss of pressure. However you may experience some "stiction" requiring a higher effort to move the gas spring for the first time after a long storage period.

Generally, ACE gas springs are tested to 70 000 to 100 000 complete strokes. This is equivalent to the seal lifetime (depending on model size) to a distance travelled of 2 km up to 10 km. During these tests the gas spring must not lose more than 5 % of its pressure. Depending upon the application and operating environment, the service life of these gas springs may be much longer. In practise 500 000 strokes or more have been achieved on some applications.

Lifetime for traction gas spring see pages 146 and 147.

### Adjustment Instructions Valve



#### Adjustment Instruction

1. Hold gas spring piston rod down.
2. Remove any fitting attached to the body end of the gas spring (GZ version the piston rod).
3. Insert adjuster knob on thread end on the cylinder body (on GZ version thread end on the piston rod). When resistance is felt, proceed slowly and with caution. This opens the valve and you can hear the nitrogen escaping and reducing pressure. Turn back the adjusting knob immediately, to avoid too much nitrogen being discharged.
4. After adjustment, remove the Adjuster knob, mount the end fittings and test the gas spring in your application. If necessary repeat the procedure.

If you use 2 gas springs in parallel, both gas springs should have the same force to avoid bending forces or side load on the application. If necessary return to ACE to refill both gas springs to the same (average) force. If too much nitrogen is discharged, the units can be returned to ACE for re-gassing.

### Gas Spring Refilling Kit



The **ACE gas spring refilling kit** gives the ability to fill, or adjust pressure (or force) of a Gas Spring on site. You gain independence and flexibility. The refilling kit includes all the parts necessary to fill your ACE gas springs on site. Only the high pressure nitrogen bottle is not included in the kit.

Gas spring refilling kit with one filling bell.  
Please indicate the thread size.

**Ordering Example:** gas spring refilling kit GS-FK-19  
additional filling bell GS-FA-M8

*"Independence and flexibility!"*

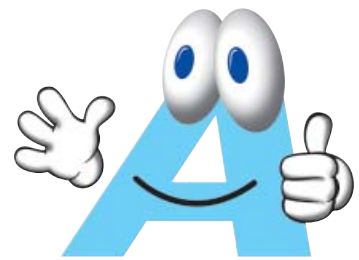

#### Available filling bells

- GS-FA-M3,5: GS- 8  
GS- 10  
GS- 12
- GS-FA-M5: GS- 15
- GS-FA-M8: GS- 19  
GS- 22  
GZ- 19
- GS-FA-M10: GS- 28  
GZ- 28
- GS-FA-M14: GS- 40



### Calculation

To obtain the ideal selection to give the optimum operation for a gas spring it is important to identify the following points:

- gas spring size
- required gas spring stroke
- mounting points on flap and frame
- extended length of the gas spring
- required extension force
- hand forces throughout the complete movement on the flap

With our **free calculation service** you can eliminate the time-consuming calculation and fax us your details. Just complete the information shown on the calculation formulae page number 136. Please attach a sketch of your application (a simple hand sketch is sufficient) in side view. Our application engineers will determine the optimum mounting points and calculate the ideal situation to satisfy your requirements.

You will receive a quotation showing the opening and closing forces and our recommended mounting points to suit your application.

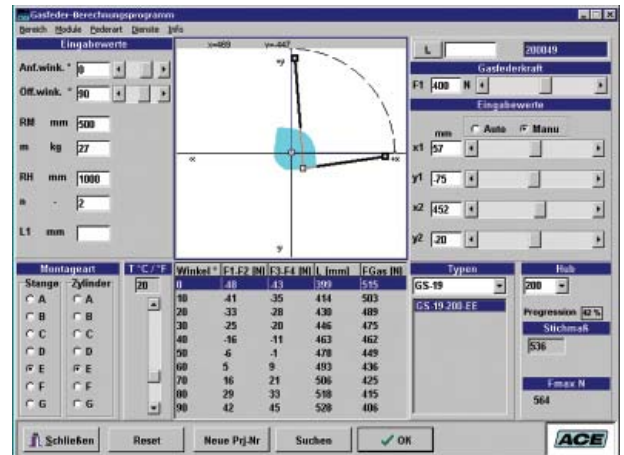

*"Calculation offer with all required details for assembly!"*

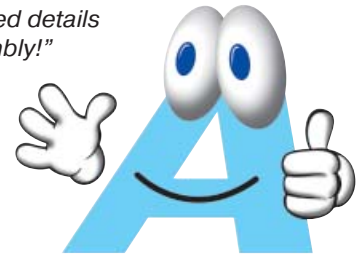

### Safety Instructions

**Gas springs are filled with pure nitrogen gas. Nitrogen is an inert gas that does not burn or explode and is not poisonous. Please note!: the internal pressure of gas springs can be up to 300 bar. Do not attempt to open or modify them.**

ACE gas springs will operate in surrounding temperatures from -20 °C to +80 °C. We can equip our springs with special seals to withstand temperatures as low as -45 °C or as high as +200 °C. Gas springs should not be placed over heat or in open fire!

Disposal/Recycling:

Gas Springs consist mostly of metal and the metal could be recycled, but first the gas pressure must be removed. Please ask for our disposal recommendations which advise how to depressurize the gas springs and make them safe to recycle.

All gas springs are marked with the part number, the production date and a warning sign "Do not open high pressure". We are not responsible for any damages of any kind that arises due to goods that are not marked accordingly.

Gas springs should be installed with the piston rod downwards. This position ensures best damping quality. Only ACE gas springs include an integrated grease chamber which allows for alternative mounting opportunities.

Gas springs should not be exposed to tilting or side load forces during operation or whilst static (this can cause bending of the piston rod or early wear).

Gas springs are maintenance-free. Do not grease or oil the piston rod.

The piston rod must not be painted and should be protected against shocks, scratches and dirt. The cylinder should not be deformed as such damage would destroy the sealing system.

ACE gas springs can be stored in any position. Pressure lost through long storage is not to be expected. There are no known negative values, but there may be a sticking effect the first time you compress a spring. This may require a higher initial force to operate the gas spring for the first time (initial breakaway force).

The tolerance for the installation length is generally deemed to be  $\pm 2$  mm. If very high demands are placed on durability and stability, please avoid the combination of small diameter + long stroke + high force.

The filling tolerance is -20 N to 40 N or 5 % to 7 %.

### Case 1 (e.g. Flap)

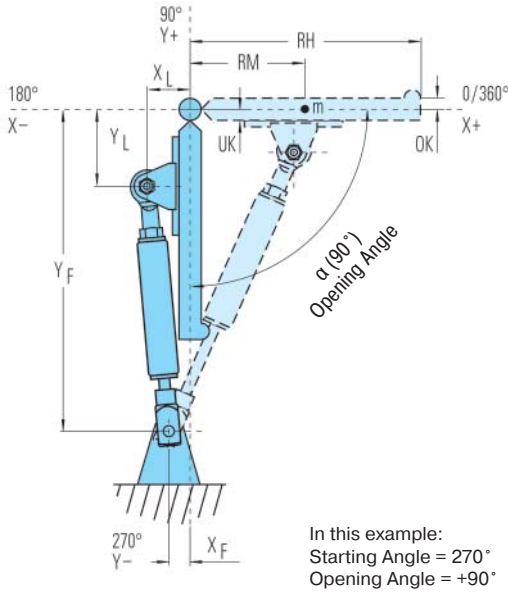

### Case 2 (e.g. Hood)

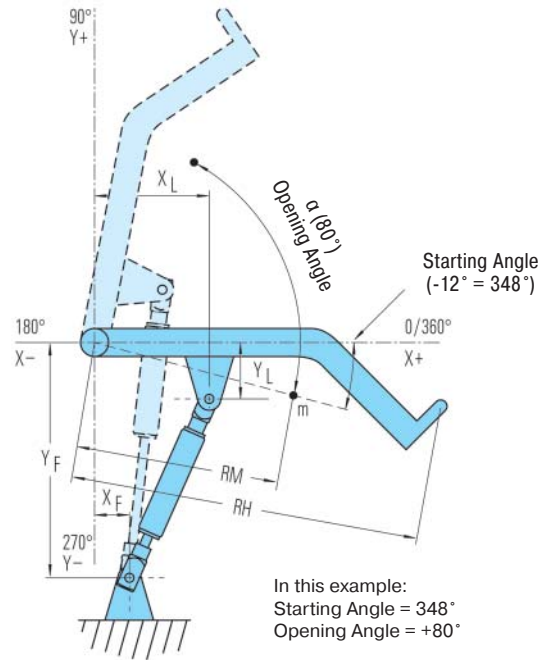

Push type  Pull type   
Case 1  Case 2  (with attached sketch only)

#### Input Date

#### Gas Spring Fixing points

The fixed point  $X_F$  and  $Y_F$  of the frame and the moving point  $X_L$  and  $Y_L$  of the flap are critical for the optimum operation. **Therefore please attach a sketch of your application on separate paper (a few lines with their dimensions are sufficient)!**

Moving mass  $m$  \_\_\_\_\_ kg  
No. of gas springs in parallel  $n$  \_\_\_\_\_ pcs  
Number of movements \_\_\_\_\_ /day  
Ambient temperature  $T$  \_\_\_\_\_ °C

#### (if not shown by the sketch)

Radius of centre of gravity  $R_M$  \_\_\_\_\_ mm  
Radius of hand force  $R_H$  \_\_\_\_\_ mm  
Starting angle ( $0^\circ$  to  $360^\circ$ ) \_\_\_\_\_ °  
Opening angle ( $-360^\circ$  to  $+360^\circ$ )  $\alpha$  \_\_\_\_\_ °  
(- = downwards, + = upwards)  
Dimensions of the flap: thickness \_\_\_\_\_ mm  
Distance between flap and pivot:  
Upper side  $O_K =$  \_\_\_\_\_ mm, Lower side  $U_K =$  \_\_\_\_\_ mm

Comments \_\_\_\_\_  
\_\_\_\_\_

#### Desired Mounting Fittings

End Fitting		End Fitting
<input type="checkbox"/> A		<input type="checkbox"/> A
<input type="checkbox"/> B	Stud Thread	<input type="checkbox"/> B
<input type="checkbox"/> C	Angle Ball Joint	<input type="checkbox"/> C
<input type="checkbox"/> D	Clevis Fork	<input type="checkbox"/> D
<input type="checkbox"/> E	Swivel Eye	<input type="checkbox"/> E
<input type="checkbox"/> F	Inline Ball Joint	<input type="checkbox"/> F
<input type="checkbox"/> G	Ball Socket	<input type="checkbox"/> G

**The end fittings are interchangeable.**

e.g.: -CE C = Angle Ball Joint, E = Swivel Eye

Requirement per year \_\_\_\_\_  
Machine type/reference \_\_\_\_\_

#### Sender

Co. \_\_\_\_\_  
Address \_\_\_\_\_  
Internet \_\_\_\_\_

Dept. \_\_\_\_\_  
Name \_\_\_\_\_  
Telephone \_\_\_\_\_ Fax \_\_\_\_\_  
E-Mail \_\_\_\_\_

**Please copy, complete and fax to ACE: Fax +49 - (0)2173 - 9226 - 89**

### End Fitting

### Standard Dimensions

### End Fitting

**Dimensions**

Type	Stroke mm	L extended
GS-8-20	20	72
GS-8-30	30	92
GS-8-40	40	112
GS-8-50	50	132
GS-8-60	60	152
GS-8-80	80	192

**Ordering Example**

GS-8-30-AC-30

Type (Push Type) \_\_\_\_\_  
 Body Ø (8 mm) \_\_\_\_\_  
 Stroke (30 mm) \_\_\_\_\_  
 Piston Rod End Fitting A3,5 \_\_\_\_\_  
 Body End Fitting C3,5 \_\_\_\_\_  
 Nominal Force F<sub>1</sub> 30 N \_\_\_\_\_

The end fittings are interchangeable.  
For mounting accessories see page 155.

**End Fitting Options:**

- A3,5: Eye A3,5
- B3,5: Stud Thread B3,5
- C3,5: Angle Ball Joint C3,5 (max. force 225 N)
- D3,5: Clevis Fork D3,5 (max. force 225 N)
- E3,5: Swivel Eye E3,5 (max. force 225 N)
- G3,5: Ball Socket G3,5 (max. force 225 N)
- U3,5: Adjuster Knob U3,5 (See page 134)

**Rod Shroud W3,5-8**

Ø 11  
L = Stroke + 10

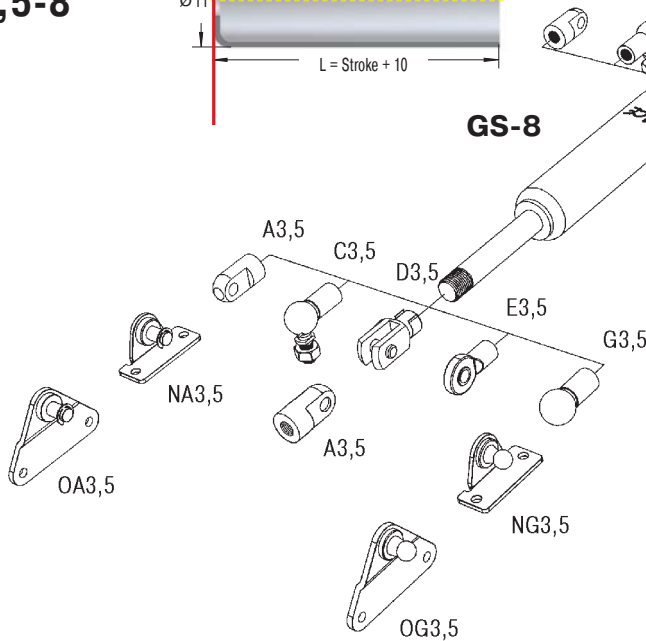

For mounting accessories see page 155.

### Technical Data

- Mounting:** In any position
- Advice:** We recommend mounting with piston rod downwards to take advantage of the built-in end position damping.
- End position damping length:** Approx. 5 mm
- Progression:** Approx. 28 %, F<sub>2</sub> max. 130 N
- Available force range F<sub>1</sub> at 20 °C:** 10 N to 100 N
- Material:** Body: Black powder coated steel. Piston rod: Stainless steel (1.4305). End fittings: Zinc plated steel.
- On request:** Without damping, extended length damping, special force curves, special lengths, alternative end fittings.

Issue 4.2009 Specifications subject to change





### End Fitting

### Standard Dimensions

### End Fitting

**Dimensions**

Type	Stroke mm	L extended
GS-15-20	20	67
GS-15-40	40	107
GS-15-50	50	127
GS-15-60	60	147
GS-15-80	80	187
GS-15-100	100	227
GS-15-120	120	267
GS-15-150	150	327
GS-15-200	200	427

**Ordering Example** **GS-15-150-AC-150**

Type (Push Type) \_\_\_\_\_  
 Body Ø (15 mm) \_\_\_\_\_  
 Stroke (150 mm) \_\_\_\_\_  
 Piston Rod End Fitting A5 \_\_\_\_\_  
 Body End Fitting C5 \_\_\_\_\_  
 Nominal Force  $F_1$  150 N \_\_\_\_\_

**The end fittings are interchangeable.**  
**For mounting accessories see page 155.**

**End Fitting Details:**  
 Eye **A5**  
 Stud Thread **B5**  
 Angle Ball Joint **C5** (max. force 500 N)  
 Clevis Fork **D5** (max. force 800 N)  
 Swivel Eye **E5** (max. force 800 N)  
 Inline Ball Joint **F5** (max. force 500 N)  
 Ball Socket **G5** (max. force 500 N)  
 Adjuster Knob **U5** (See page 134.)

**Rod Shroud W5-15**  
 Ø 19  
 L = Stroke + 20

### Technical Data

**Mounting:** In any position

**Advice:** We recommend mounting with piston rod downwards to take advantage of the built-in end position damping.

**End position damping length:** Approx. 10 mm

**Progression:** Approx. 27 %,  $F_2$  max. 500 N

**Available force range  $F_1$  at 20 °C:** 20 N to 400 N

**Material:** Body: Black powder coated steel. Piston rod: Ceramic coated steel. End fittings: Zinc plated steel.

**On request:** Without damping, increased damping action at end of travel, special force curves, special lengths, strokes, alternative end fittings, stainless steel (see pages 148 to 153).

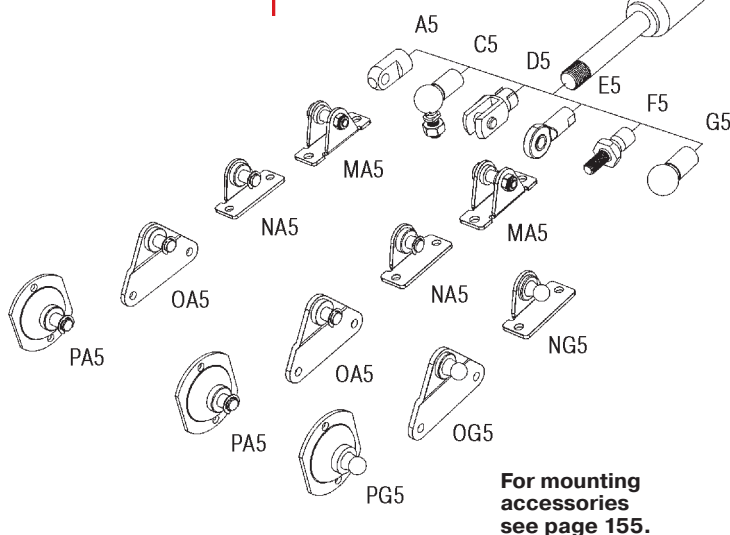

### End Fitting

### Standard Dimensions

### End Fitting

**End Fitting**  
A8 Eye A8

**End Fitting**  
B8 Stud Thread B8

**End Fitting**  
C8 Angle Ball Joint C8 (max. force 1200 N)

**End Fitting**  
D8 Clevis Fork D8 (max. force 3000 N)

**End Fitting**  
E8 Swivel Eye E8 (max. force 3000 N)

**End Fitting**  
F8 Inline Ball Joint F8 (max. force 1200 N)

**End Fitting**  
G8 Ball Socket G8 (max. force 1200 N)

**End Fitting**  
U8 Adjuster Knob U8 See page 134.

**Dimensions**

Type	Stroke mm	L aextended
GS-19-50	50	164
GS-19-100	100	264
GS-19-150	150	364
GS-19-200	200	464
GS-19-250	250	564
GS-19-300	300	664

**Ordering Example** **GS-19-150-AC-600**

Type (Push Type) \_\_\_\_\_  
 Body Ø (19 mm) \_\_\_\_\_  
 Stroke (150 mm) \_\_\_\_\_  
 Piston Rod End Fitting A8 \_\_\_\_\_  
 Body End Fitting C8 \_\_\_\_\_  
 Nominal Force F<sub>1</sub> 600 N \_\_\_\_\_

The end fittings are interchangeable.  
For mounting accessories see page 156.

**Rod Shroud W8-19**  
L = Stroke + 30

### Technical Data

- Mounting:** In any position
- Advice:** We recommend mounting with piston rod downwards to take advantage of the built-in end position damping.
- End position damping length:** Strong end position damping approx. 20 to 60 mm (depending on the stroke) and slow extension speed.
- Progression:** Approx. 36 % to 42 %, F<sub>2</sub> max. 995 N
- Available force range F<sub>1</sub> at 20 °C:** 50 N to 700 N
- Material:** Body: Black powder coated steel. Piston rod: Ceramic coated steel. End fittings: Zinc plated steel.
- On request:** Without damping, standard length damping, special force curves, special lengths, alternative end fittings, stainless steel (see pages 148 to 153).

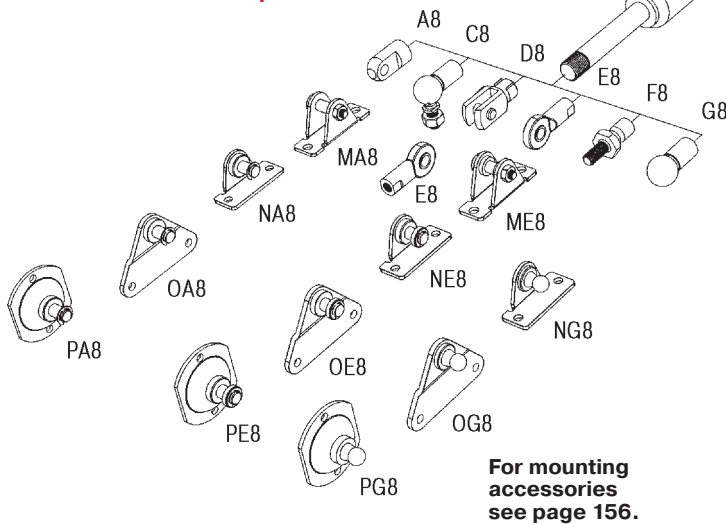

### End Fitting

### Standard Dimensions

### End Fitting

**A8**

Radius R7

14

20

10 thick

Stroke

Ø10

Ø14

Ø8,1

**Dimensions**

Type	Stroke mm	L extended
GS-22-50	50	164
GS-22-100	100	264
GS-22-150	150	364
GS-22-200	200	464
GS-22-250	250	564
GS-22-300	300	664
GS-22-350	350	764
GS-22-400	400	864
GS-22-450	450	964
GS-22-500	500	1 064
GS-22-550	550	1 164
GS-22-600	600	1 264
GS-22-650	650	1 364
GS-22-700	700	1 464

**Ordering Example**

**GS-22-150-AE-800**

Type (Push Type) \_\_\_\_\_

Body Ø (22 mm) \_\_\_\_\_

Stroke (150 mm) \_\_\_\_\_

Piston Rod End Fitting A8 \_\_\_\_\_

Body End Fitting E8 \_\_\_\_\_

Nominal Force F<sub>1</sub> 800 N \_\_\_\_\_

**The end fittings are interchangeable.**  
**For mounting accessories see page 156.**

**Eye A8**

**Stud Thread B8**

**Angle Ball Joint C8**  
(max. force 1 200 N)

**Clevis Fork D8**  
(max. force 3 000 N)

**Swivel Eye E8**  
(max. force 3 000 N)

**Inline Ball Joint F8**  
(max. force 1 200 N)

**Ball Socket G8**  
(max. force 1 200 N)

**Adjuster Knob U8**  
See page 134.

**Rod Shroud W8-22**

Ø28

L = Stroke + 30

### Rod Shroud W8-22

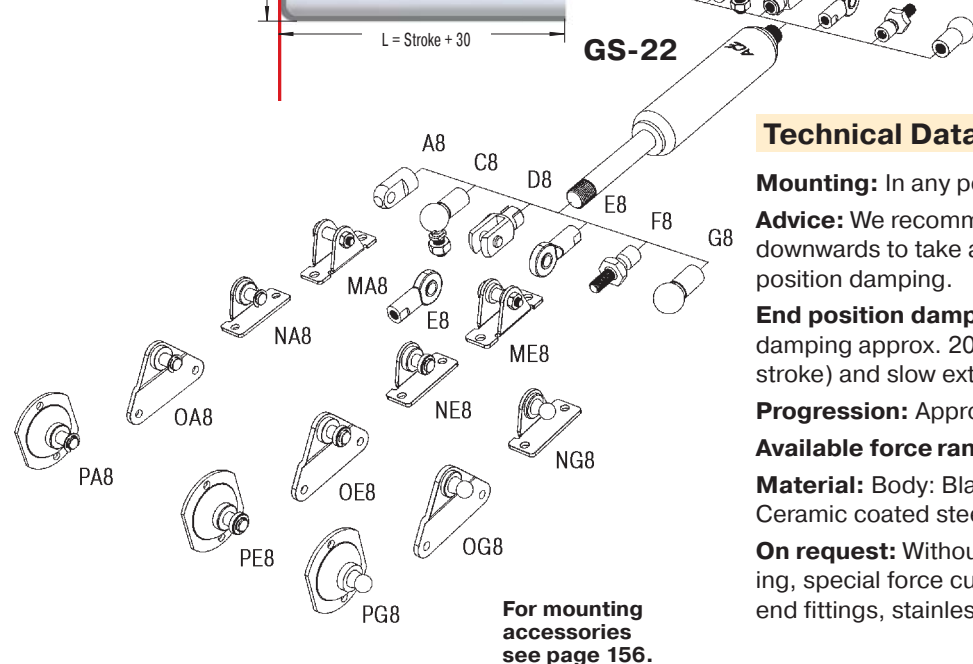

**For mounting accessories see page 156.**

### Technical Data

- Mounting:** In any position
- Advice:** We recommend mounting with piston rod downwards to take advantage of the built-in end position damping.
- End position damping length:** Strong end position damping approx. 20 to 70 mm (depending on the stroke) and slow extension speed.
- Progression:** Approx. 39 % to 50 %, F<sub>2</sub> max. 1 950 N
- Available force range F<sub>1</sub> at 20 °C:** 80 N to 1 300 N
- Material:** Body: Black powder coated steel. Piston rod: Ceramic coated steel. End fittings: Zinc plated steel.
- On request:** Without damping, standard length damping, special force curves, special lengths, alternative end fittings, stainless steel (see pages 148 to 153).

Issue 4.2009 Specifications subject to change

### End Fitting

### Standard Dimensions

### End Fitting

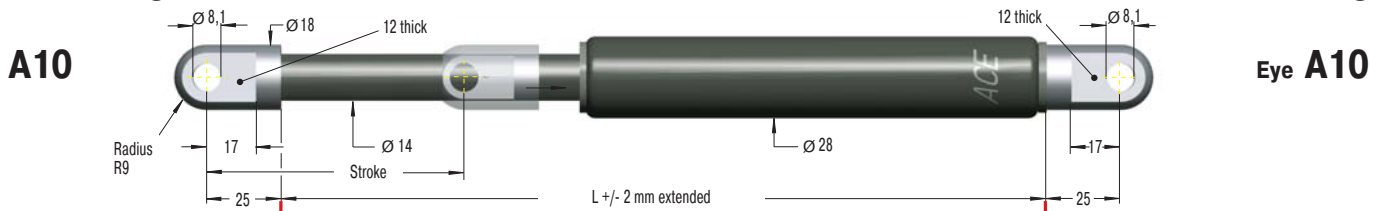

### B10

### Stud Thread B10

### C10

### Angle Ball Joint C10 (max. force 1800 N)

### D10

### Clevis Fork D10 (max. force 10000 N)

### E10

### Swivel Eye E10 (max. force 10000 N)

### F10

### Inline Ball Joint F10 (max. force 1800 N)

### Rod Shroud W10-28

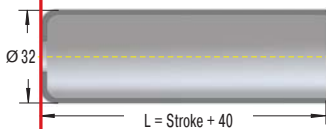

### Dimensions

Type	Stroke mm	L extended
GS-28-100	100	262
GS-28-150	150	362
GS-28-200	200	462
GS-28-250	250	562
GS-28-300	300	662
GS-28-350	350	762
GS-28-400	400	862
GS-28-450	450	962
GS-28-500	500	1 062
GS-28-550	550	1 162
GS-28-600	600	1 262
GS-28-650	650	1 362
GS-28-700	700	1 462
GS-28-750	750	1 562

### Ordering Example

GS-28-150-EE-1200

Type (Push Type) \_\_\_\_\_  
 Body Ø (28 mm) \_\_\_\_\_  
 Stroke (150 mm) \_\_\_\_\_  
 Piston Rod End Fitting E10 \_\_\_\_\_  
 Body End Fitting E10 \_\_\_\_\_  
 Nominal Force  $F_1$  1200 N \_\_\_\_\_

The end fittings are interchangeable.  
For mounting accessories see page 156.

### Technical Data

**Mounting:** In any position

**Advice:** We recommend mounting with piston rod downwards to take advantage of the built-in end position damping.

**End position damping length:** Strong end position damping approx. 30 to 70 mm (depending on the stroke) and slow extension speed.

**Progression:** Approx. 60 % to 95 %,  $F_2$  max. 4875 N

**Available force range  $F_1$  at 20 °C:** 150 N to 2500 N

**Material:** Body: Black powder coated steel. Piston rod: Ceramic coated steel. End fittings: Zinc plated steel.

**On request:** Without damping, standard length damping, special force curves, special lengths, alternative end fittings, stainless steel (see pages 148 to 153).

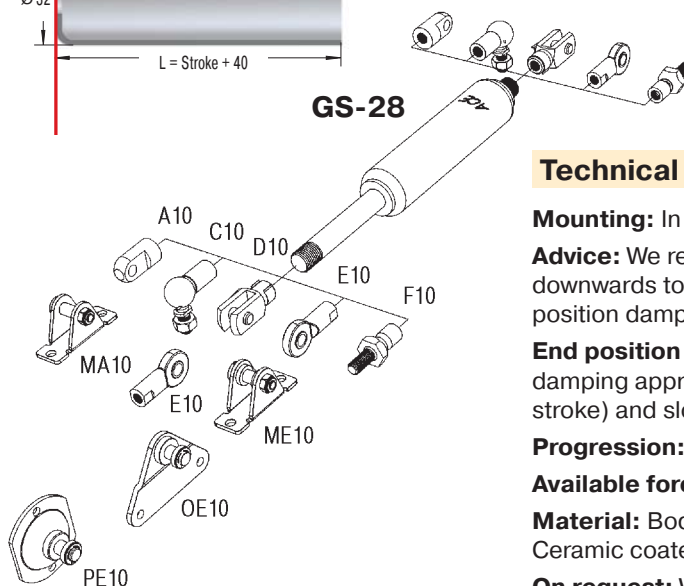

For mounting accessories see page 156.

### Adjuster Knob U10 See page 134.

### End Fitting

### Standard Dimensions

### End Fitting

**A14**

Radius R12,5

Ø14,1

Ø25

14 thick

21

40

**Dimensions**

Type	Stroke mm	L extended
GS-40-100	100	317
GS-40-150	150	417
GS-40-200	200	517
GS-40-300	300	717
GS-40-400	400	917
GS-40-500	500	1 117
GS-40-600	600	1 317
GS-40-800	800	1 717
GS-40-1000	1 000	2 117

**Ordering Example** **GS-40-150-DD-3500**

Type (Push Type) \_\_\_\_\_

Body Ø (40 mm) \_\_\_\_\_

Stroke (150 mm) \_\_\_\_\_

Piston Rod End Fitting D14 \_\_\_\_\_

Body End Fitting D14 \_\_\_\_\_

Nominal Force F<sub>1</sub> 3500 N \_\_\_\_\_

**The end fittings are interchangeable.**  
**For mounting accessories see page 157.**

**Eye A14**

14 thick

Ø14,1

21

40

**Stud Thread B14**

M14x1,5

15

**Angle Ball Joint C14**  
(max. force 3 200 N)

Ø30

Ø22

20

25

28

45

M14x1,5

36°

**Clevis Fork D14**  
(max. force 10 000 N)

Ø14

27

14

16

27

56

**Swivel Eye E14**  
(max. force 10 000 N)

30°

Ø14

13

Ø20

Ø26

19

18

57

30

**Inline Ball Joint F14**  
(max. force 3 200 N)

M14x1,5

30°

AF24

AF22

40

56

18

**Adjuster Knob U14**  
See page 134.

**Rod Shroud W14-40**

Ø45

L = Stroke + 40

**GS-40**

**For mounting accessories see page 157.**

### Technical Data

**Mounting:** In any position

**Advice:** We recommend mounting with piston rod downwards to take advantage of the built-in end position damping.

**End position damping length:** Strong end position damping approx. 30 to 70 mm (depending on the stroke) and slow extension speed.

**Progression:** Approx. 47 % to 53 %, F<sub>2</sub> max. 7 650 N

**Available force range F<sub>1</sub> at 20 °C:** 500 N to 5 000 N

**Material:** Body: Black powder coated steel. Piston rod: Ceramic coated steel. End fittings: Zinc plated steel.

**On request:** Without damping, standard length damping, special force curves, special lengths, alternative end fittings, stainless steel (see pages 148 to 153).

### End Fitting

### Standard Dimensions

### End Fitting

**B24**

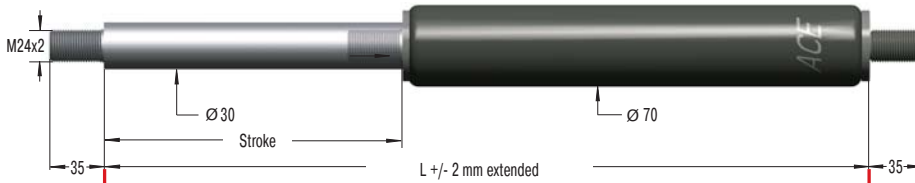

Stud Thread **B24**

**D24**

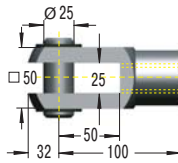

**Clevis Fork D24**  
(max. force 50 000 N)

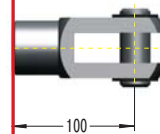

**E24**

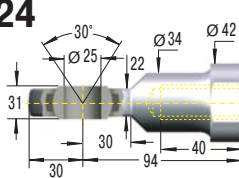

**Swivel Eye E24**  
(max. force 50 000 N)

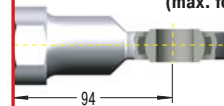

### Dimensions

Type	Stroke mm	L extended
GS-70-100	100	320
GS-70-200	200	520
GS-70-300	300	720
GS-70-400	400	920
GS-70-500	500	1 120
GS-70-600	600	1 320
GS-70-700	700	1 520
GS-70-800	800	1 720

### Ordering Example

**GS-70-200-EE-8000**

Type (Push Type) \_\_\_\_\_  
 Body Ø (70 mm) \_\_\_\_\_  
 Stroke (200 mm) \_\_\_\_\_  
 Piston Rod End Fitting E24 \_\_\_\_\_  
 Body End Fitting E24 \_\_\_\_\_  
 Nominal Force  $F_1$  8000 N \_\_\_\_\_

The end fittings are interchangeable.  
 For mounting accessories see page 157.  
 Standard gas spring with valve.

**Rod Shroud**  
**W24-70**

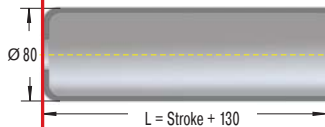

**GS-70**

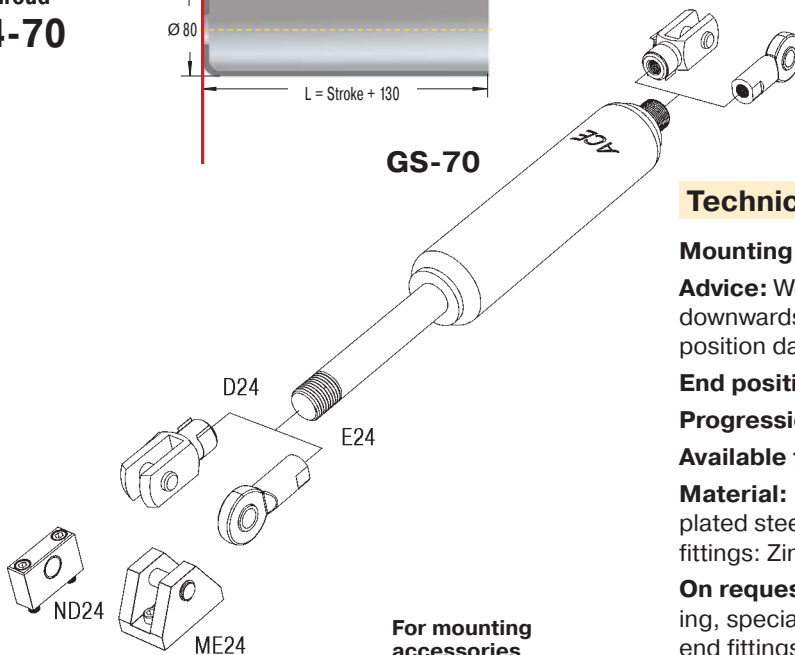

For mounting accessories see page 157.

### Technical Data

**Mounting:** In any position

**Advice:** We recommend mounting with piston rod downwards to take advantage of the built-in end position damping.

**End position damping length:** Approx. 10 mm

**Progression:** Approx. 25 %,  $F_2$  max. 16250 N

**Available force range  $F_1$  at 20 °C:** 2000 N to 13000 N

**Material:** Body: Black powder coated steel or zinc plated steel. Piston rod: Hard chrome plated. End fittings: Zinc plated steel.

**On request:** Without damping, extended length damping, special force curves, special lengths, alternative end fittings, stainless steel.

### End Fitting

### Standard Dimensions

### End Fitting

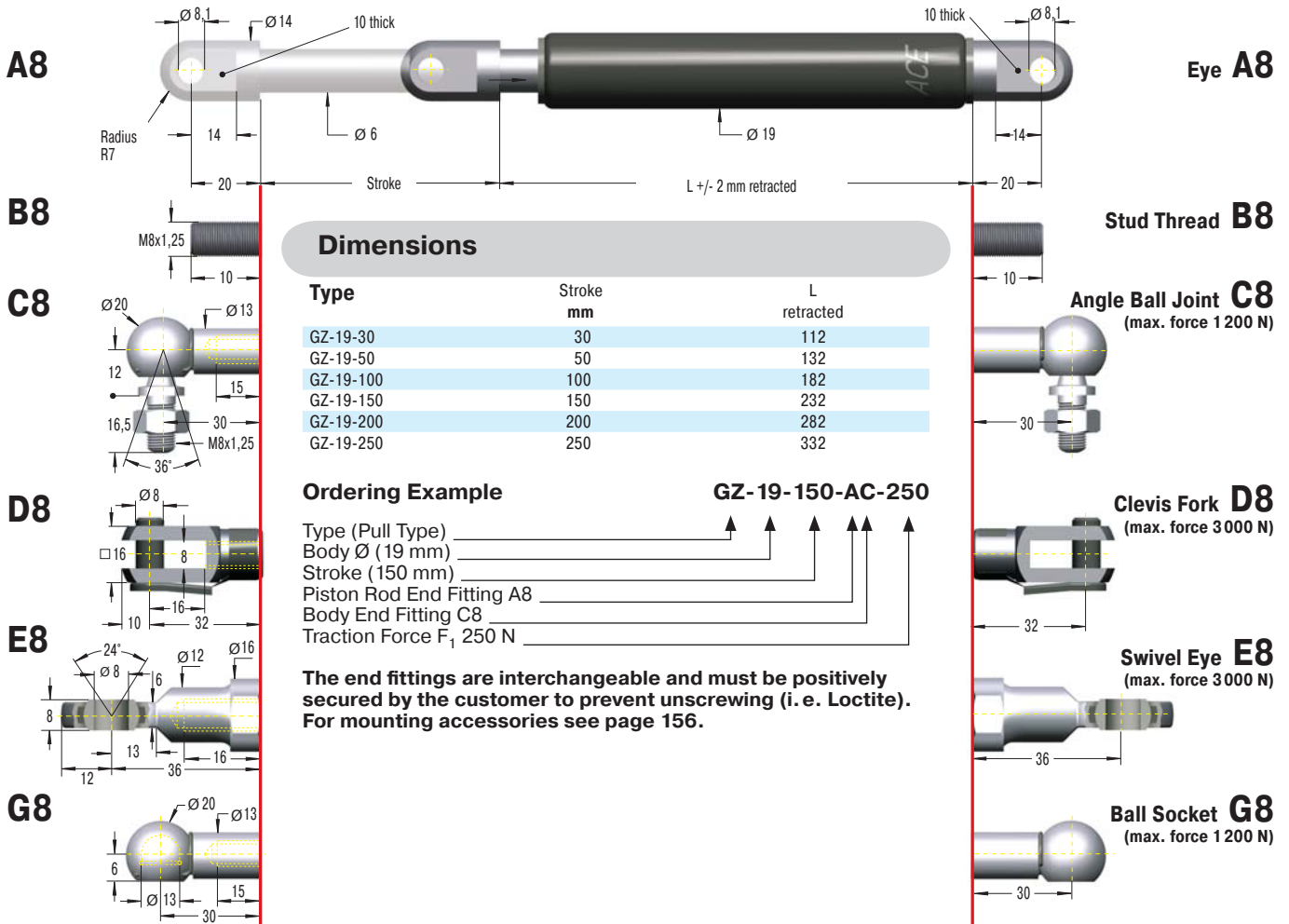

### Dimensions

Type	Stroke mm	L retracted
GZ-19-30	30	112
GZ-19-50	50	132
GZ-19-100	100	182
GZ-19-150	150	232
GZ-19-200	200	282
GZ-19-250	250	332

### Ordering Example

### GZ-19-150-AC-250

Type (Pull Type) \_\_\_\_\_  
 Body Ø (19 mm) \_\_\_\_\_  
 Stroke (150 mm) \_\_\_\_\_  
 Piston Rod End Fitting A8 \_\_\_\_\_  
 Body End Fitting C8 \_\_\_\_\_  
 Traction Force F<sub>1</sub> 250 N \_\_\_\_\_

The end fittings are interchangeable and must be positively secured by the customer to prevent unscrewing (i. e. Loctite). For mounting accessories see page 156.

### Rod Shroud W8-19

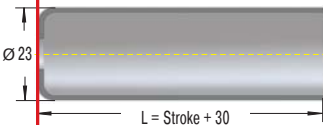

### Adjuster Knob UZ8

See page 134.

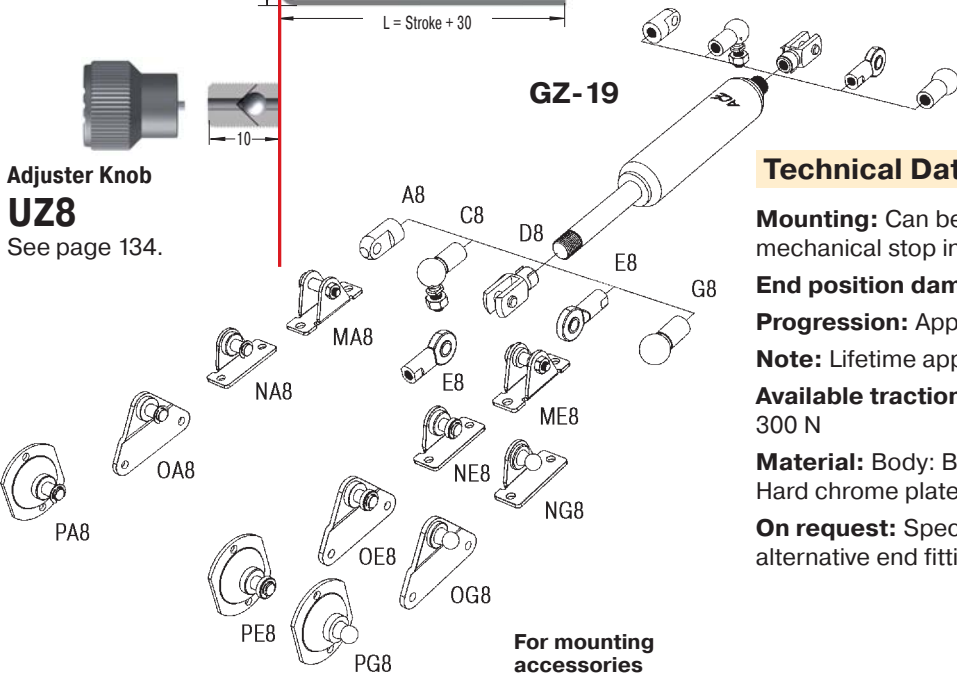

For mounting accessories see page 156.

### Technical Data

**Mounting:** Can be mounted in any position. Install mechanical stop in extended position.

**End position damping length:** Without damping.

**Progression:** Approx. 10 %, F<sub>2</sub> max. 330 N

**Note:** Lifetime approx. 2000 m

**Available traction force range F<sub>1</sub> at 20 °C:** 30 N to 300 N

**Material:** Body: Black powder coated steel. Piston rod: Hard chrome plated. End fittings: Zinc plated steel.

**On request:** Special force curves, special lengths, alternative end fittings, stainless steel.

### End Fitting

### Standard Dimensions

### End Fitting

**A10**

**B10**

**C10**

**D10**

**E10**

### Dimensions

Type	Stroke mm	L retracted
GZ-28-30	30	130
GZ-28-50	50	150
GZ-28-100	100	200
GZ-28-150	150	250
GZ-28-200	200	300
GZ-28-250	250	350
GZ-28-300	300	400
GZ-28-350	350	450
GZ-28-400	400	500
GZ-28-450	450	550
GZ-28-500	500	600
GZ-28-550	550	650
GZ-28-600	600	700
GZ-28-650	650	750

**Ordering Example** **GZ-28-150-EE-800**

Type (Pull Type) \_\_\_\_\_

Body Ø (28 mm) \_\_\_\_\_

Stroke (150 mm) \_\_\_\_\_

Piston Rod End Fitting E10 \_\_\_\_\_

Body End Fitting E10 \_\_\_\_\_

Traction Force F<sub>1</sub> 800 N \_\_\_\_\_

**The end fittings are interchangeable and must be positively secured by the customer to prevent unscrewing (i.e. Loctite). For mounting accessories see page 156.**

**Eye A10**

**Stud Thread B10**

**Angle Ball Joint C10**  
(max. force 1800 N)

**Clevis Fork D10**  
(max. force 10000 N)

**Swivel Eye E10**  
(max. force 10000 N)

### Rod Shroud W10-28

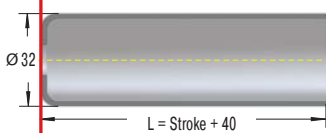

### Adjuster Knob UZ10

See page 134.

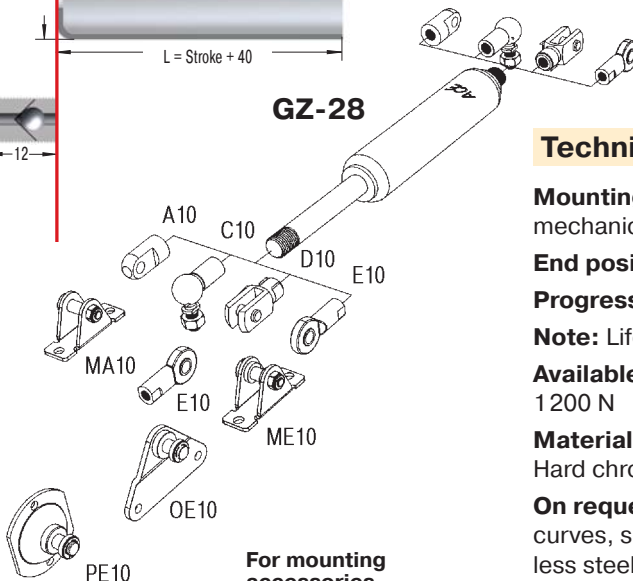

**For mounting accessories see page 156.**

### Technical Data

- Mounting:** Can be mounted in any position. Install mechanical stop in extended position.
- End position damping length:** Without damping.
- Progression:** Approx. 20 %, F<sub>2</sub> max. 1440 N
- Note:** Lifetime approx. 2000 m
- Available traction force range F<sub>1</sub> at 20 °C:** 150 N to 1200 N
- Material:** Body: Black powder coated steel. Piston rod: Hard chrome plated. End fittings: Zinc plated steel.
- On request:** Increased traction force, special force curves, special lengths, alternative end fittings, stainless steel.