

ACE rotary dampers are sealed maintenance-free units. They are available with fixed or adjustable damping rates. The damping can be clockwise, anticlockwise or in both directions. The outer body is either plastic or metal depending upon model size. The output connection can be direct onto the keyed output shaft or indirect via a plastic gear (available with 4 standard modules). Plastic racks with modules of 0.5 to 1 are also available. Applications include office machinery, lids and flaps, floppy disc drives, piano lids, CD players, auto glove-boxes, vending machines, medical equipment, furniture industry and a multitude of other uses.

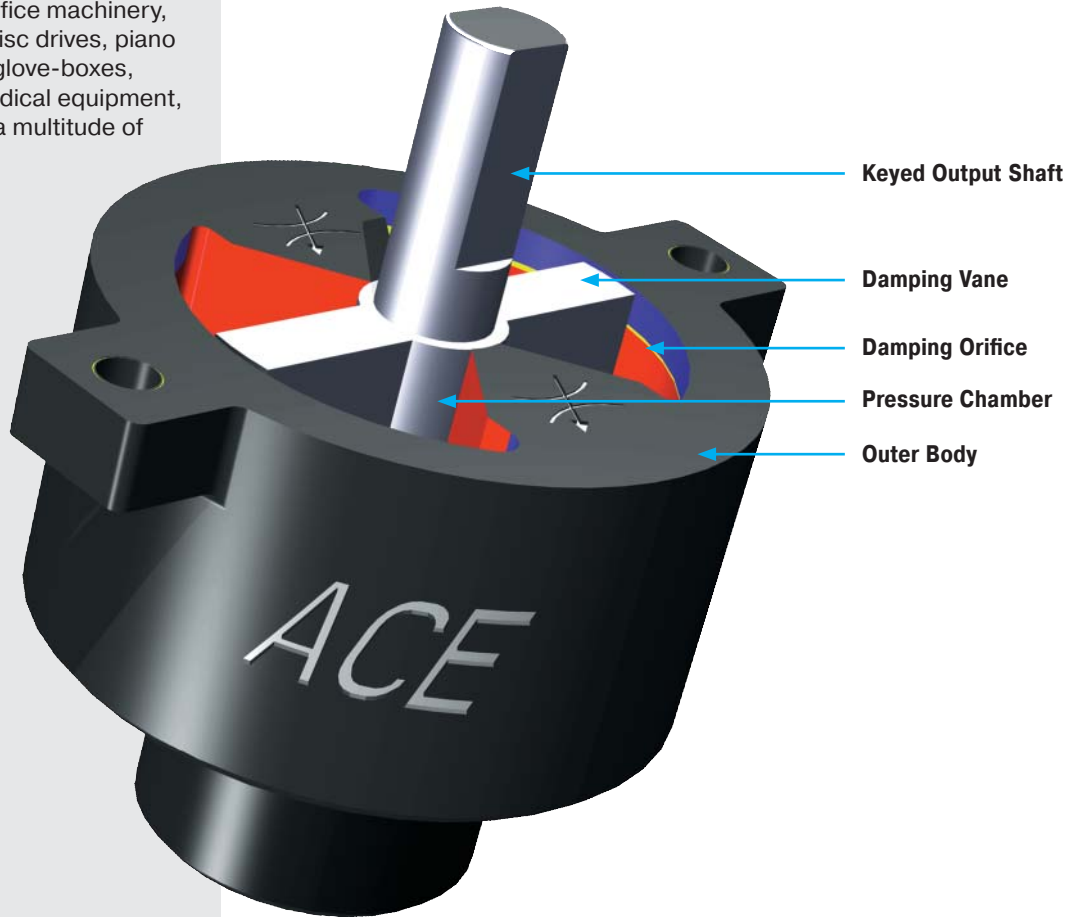

Function: ACE rotary dampers guarantee the smooth controlled opening and closing of small lids, covers and flaps. They can be mounted directly on the pivot axis or can be used to provide linear damping by using a plastic gear and rack. They enable mechanisms to operate with a smooth controlled motion giving that “touch of quality” to whatever product they are used on. ACE rotary dampers are filled with a special high viscosity fluid (silicone type) and sealed for life. The fluid is passed through an orifice or groove by a rotating vane to provide damping resistance. The damping torque generated is determined by the fluid viscosity and by the orifice configuration.

Note: With a max. rotational speed of 50 revs/min and a maximum of 10 cycles/min (12 cycles/min with the FDT/FDN types) the rotary dampers still provide more than 80% of their damping torque after a working life of 50 000 cycles.



FRT-E2

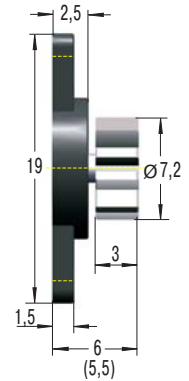
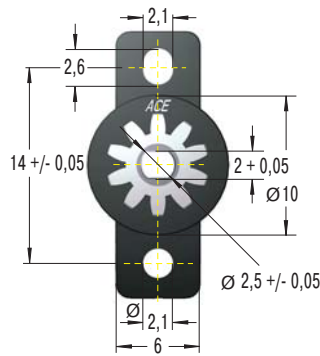

Dims. in () without gear

Damping in both Directions of Rotation

Without Gear	With Gear	Damping Torque Ncm (Nominal 20 rpm. 23 °C)
FRT-E2-100	FRT-E2-100-G1	0.10 +/- 0.05
FRT-E2-200	FRT-E2-200-G1	0.20 +/- 0.07
FRT-E2-300	FRT-E2-300-G1	0.30 +/- 0.08
FRT-E2-400	FRT-E2-400-G1	0.40 +/- 0.10

Material: Polycarbonate plastic
 Operating temperature range: 0 °C to 50 °C
 Tooth: Involute
 Module: 1.0.6
 Pressure angle: 20 °
 No. of teeth: 10
 P.C.D.: 6 mm

FRT-E2 (at 23 °C)

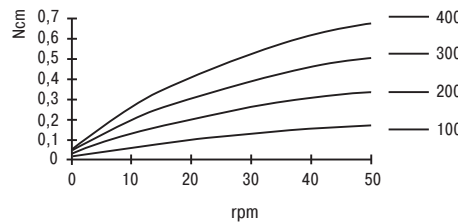

FRT-E2 (at 20 rpm)

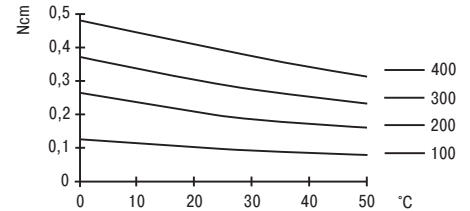

¹ A 250 mm long plastic rack is available for use with this part see page 110.

FRT-G2

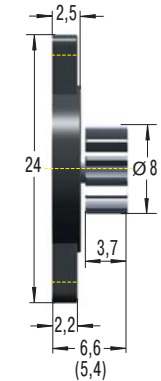
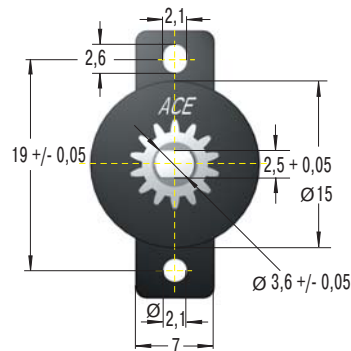

Dims. in () without gear

Damping in both Directions of Rotation

Without Gear	With Gear	Damping Torque Ncm (Nominal 20 rpm. 23 °C)
FRT-G2-200	FRT-G2-200-G1	0.20 +/- 0.07
FRT-G2-300	FRT-G2-300-G1	0.30 +/- 0.08
FRT-G2-450	FRT-G2-450-G1	0.45 +/- 0.10
FRT-G2-600	FRT-G2-600-G1	0.60 +/- 0.12
FRT-G2-101	FRT-G2-101-G1	1.00 +/- 0.20

Material: Polycarbonate plastic
 Operating temperature range: 0 °C to 50 °C
 Tooth: Involute
 Module: 1.0.5
 Pressure angle: 20 °
 No. of teeth: 14
 P.C.D.: 7 mm

FRT-G2 (at 23 °C)

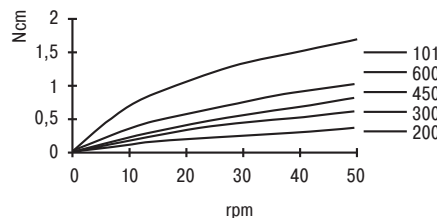

FRT-G2 (at 20 rpm)

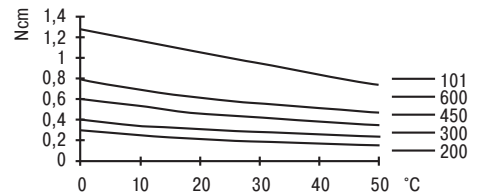

¹ A 250 mm long plastic rack is available for use with this part see page 110.

FRT-C2 and FRN-C2

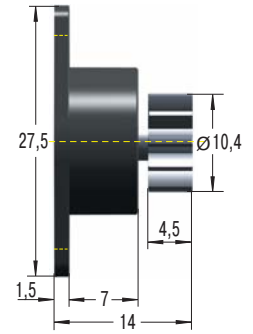
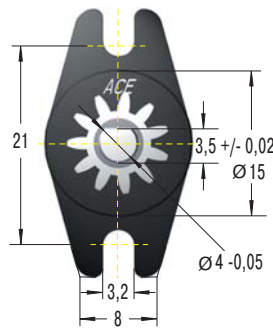
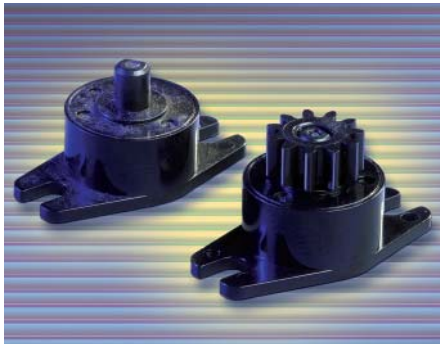

Bidirectional Damping	Right-Hand Damping (clockwise)	Left-Hand Damping (anti-clockwise)	Model	Damping Torque Ncm (Nominal 20 rpm, 23 °C)
FRT-C2-201	FRN-C2-R201	FRN-C2-L201	without gear	2 +/- 0.6
FRT-C2-201-G1	FRN-C2-R201-G1	FRN-C2-L201-G1	with gear	2 +/- 0.6
FRT-C2-301	FRN-C2-R301	FRN-C2-L301	without gear	3 +/- 0.8
FRT-C2-301-G1	FRN-C2-R301-G1	FRN-C2-L301-G1	with gear	3 +/- 0.8

Material: Polycarbonate plastic
 Operating temperature range: 0 °C to 50 °C
 Tooth: Involute
 Module: 1.0.8
 Pressure angle: 20 °
 No. of teeth: 11
 P.C.D.: 8.8 mm

FRT/N-C2 (at 23 °C)

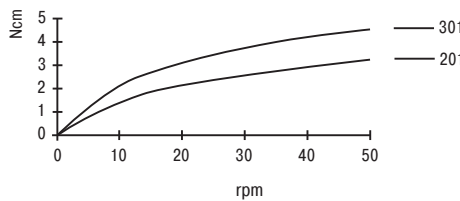

FRT/N-C2 (at 20 rpm)

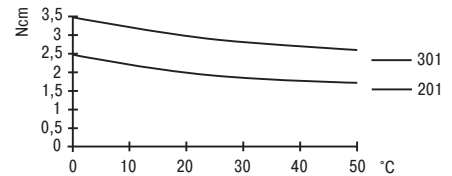

¹ A 170 mm long flexible plastic rack and a 250 mm long rigid rack are available for use with this part see page 110.

FRT-D2 and FRN-D2

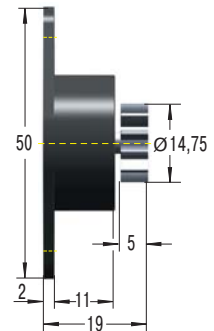
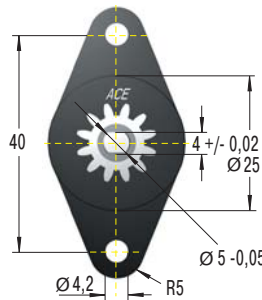

Bidirectional Damping	Right-Hand Damping (clockwise)	Left-Hand Damping (anti-clockwise)	Model	Damping Torque Ncm (Nominal 20 rpm, 23 °C)
FRT-D2-102	FRN-D2-R102	FRN-D2-L102	without gear	10 +/- 2
FRT-D2-102-G1	FRN-D2-R102-G1	FRN-D2-L102-G1	with gear	10 +/- 2
FRT-D2-152	FRN-D2-R152	FRN-D2-L152	without gear	15 +/- 3
FRT-D2-152-G1	FRN-D2-R152-G1	FRN-D2-L152-G1	with gear	15 +/- 3
FRT-D2-501	FRN-D2-R501	FRN-D2-L501	without gear	5 +/- 1
FRT-D2-501-G1	FRN-D2-R501-G1	FRN-D2-L501-G1	with gear	5 +/- 1

Material: Polycarbonate plastic
 Operating temperature range: 0 °C to 50 °C
 Tooth: Involute
 Module: 1.1.0
 Pressure angle: 20 °
 No. of teeth: 12
 P.C.D.: 12 mm

FRT/N-D2 (at 23 °C)

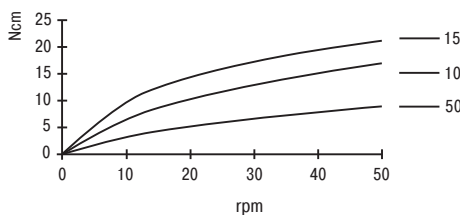

FRT/N-D2 (at 20 rpm)

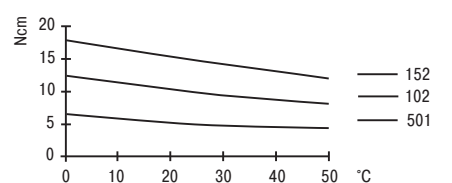

¹ A 250 mm and 500 mm long plastic rack are available for use with this part see page 110.

FYN-P1

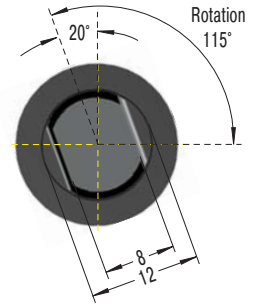
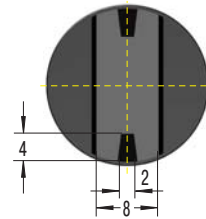
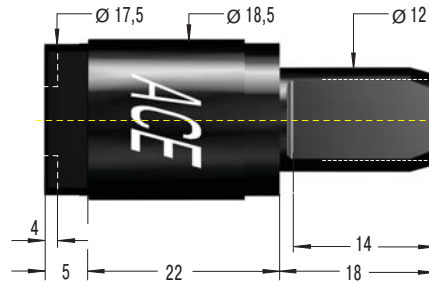

Right-Hand Damping (clockwise) black	Left-Hand Damping (anti-clockwise) white	Damping Torque Ncm	Return Damping Torque Ncm
FYN-P1-R103	FYN-P1-L103	100	30
FYN-P1-R153	FYN-P1-L153	150	50
FYN-P1-R183	FYN-P1-L183	180	80

Material: Polycarbonate plastic
 Operating temperature range: -5 °C to 50 °C
 Weight: 0.010 kg
 Max. rotation angle: 115°

Do not use damper as final end stop.
 Fit external mechanical stops at each end of travel.

"Coloured shaft for identification of the damping direction!"



FYN-N1

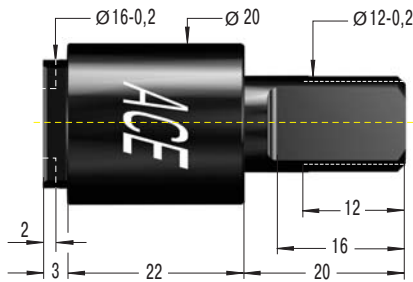

white end cap: left-hand damping
 black end cap: right-hand damping

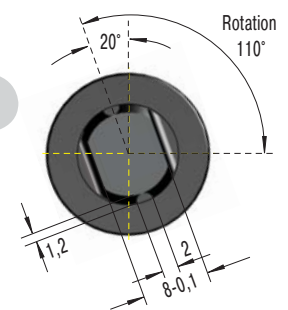
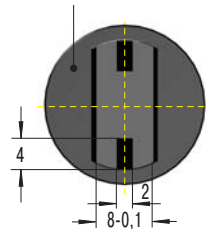

Right-Hand Damping (clockwise)	Left-Hand Damping (anti-clockwise)	Damping Torque Ncm	Return Damping Torque Ncm
FYN-N1-R103	FYN-N1-L103	100	20
FYN-N1-R203	FYN-N1-L203	200	40
FYN-N1-R253	FYN-N1-L253	250	40
FYN-N1-R303	FYN-N1-L303	300	80

Material: Polycarbonate plastic
 Operating temperature range: -5 °C to 50 °C
 Weight: 0.012 kg
 Max. rotation angle: 110°

Do not use damper as final end stop.
 Fit external mechanical stops at each end of travel.

"Coloured end cap for identification of the damping direction!"



FYN-U1

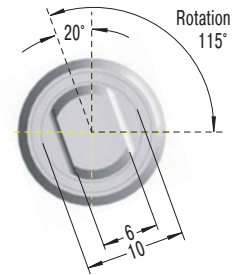
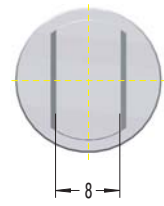
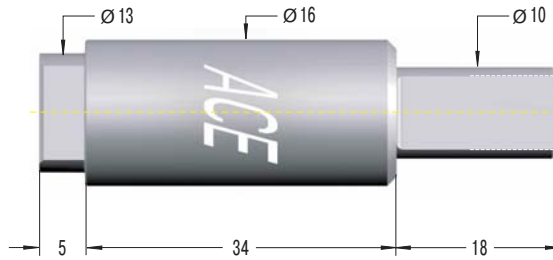

Right-Hand Damping (clockwise)	Left-Hand Damping (anti-clockwise)	Damping Torque Ncm	Return Damping Torque Ncm
FYN-U1-R203	FYN-U1-L203	200	40
FYN-U1-R253	FYN-U1-L253	250	40
FYN-U1-R303	FYN-U1-L303	300	80

Material: Zinc diecast
 Operating temperature range: -5 °C to 50 °C
 Weight: 0.04 kg
 Max. rotation angle: 115°

Do not use damper as final end stop.
 Fit external mechanical stops at each end of travel.

FYN-K1

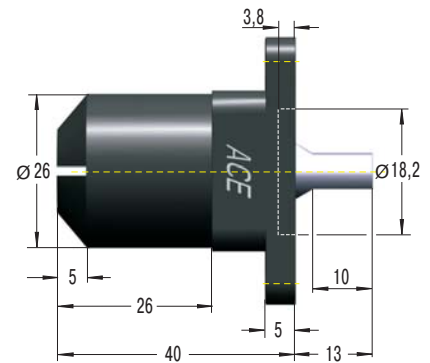
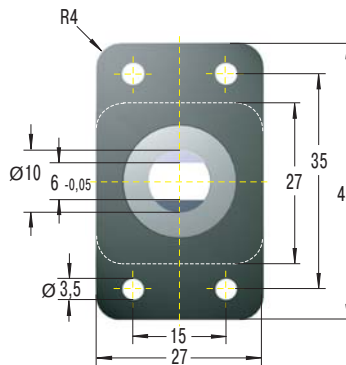

Right-Hand Damping (clockwise)	Left-Hand Damping (anti-clockwise)	Damping Torque Ncm
FYN-K1-R	FYN-K1-L	400

Material: Polycarbonate plastic
 Operating temperature range: -5 °C to 50 °C
 Max. rotation angle: 108°
 Return Damping Torque: 100 Ncm
 Weight: 0.035 kg

Do not use damper as final end stop.
 Fit external mechanical stops at each end of travel.

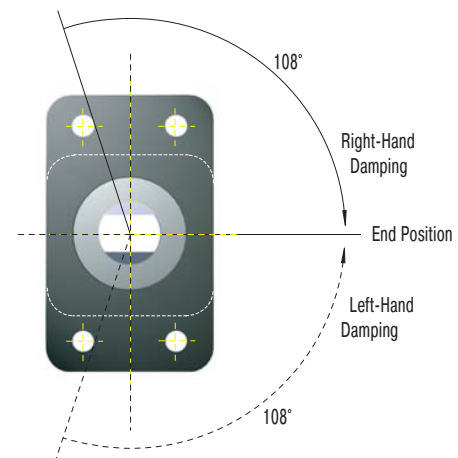

Issue 4.2009 Specifications subject to change

FRT/FRN-K2 and FRT/FRN-F2

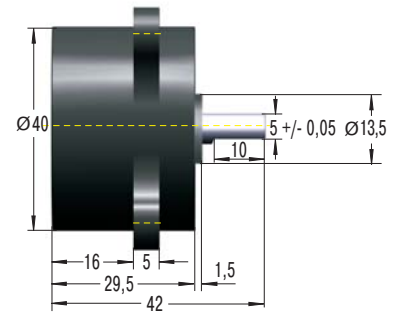
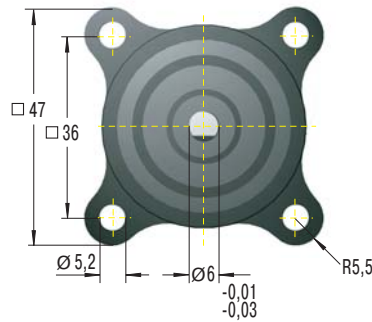

Bidirectional Damping	Right-Hand Damping (clockwise)	Left-Hand Damping (anti-clockwise)	Damping Torque Ncm (Nominal 20 rpm. 23 °C)
FRT-K2-502	FRN-K2-R502	FRN-K2-L502	50 +/- 10
FRT-K2-103	FRN-K2-R103	FRN-K2-L103	100 +/- 20
FRT-F2-203	FRN-F2-R203	FRN-F2-L203	200 +/- 40
FRT-F2-303	-	-	300 +/- 80
FRT-F2-403	-	-	400 +/- 100

Material: Polycarbonate plastic
 Operating temperature range: 0 °C to 50 °C
 Weight: max. 0.116 kg

FRT-K2 and -F2 (at 23 °C)

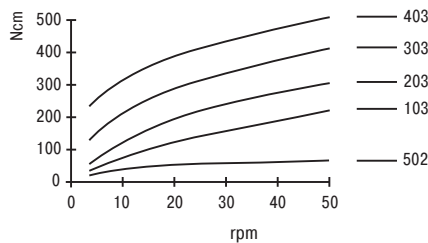

FRT-K2 and -F2 (at 20 rpm)

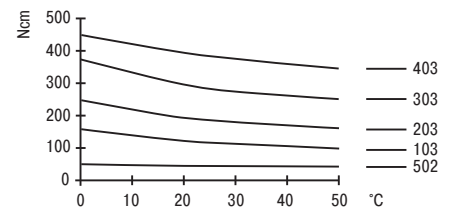

FFD

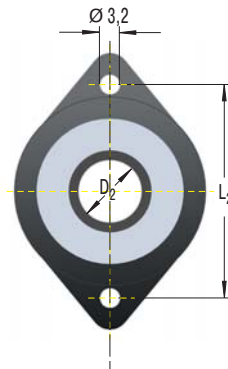

Flange Type

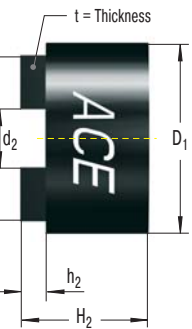
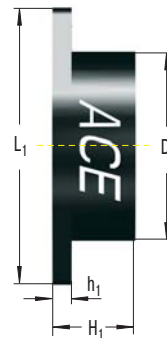

Standard Type

Type	Damping Torque Nm	Damping Option ¹	Dimensions		Flange Type				Standard Type				
			D ₁	D ₂	H ₁	h ₁	L ₁	L ₂	d ₁	d ₂	H ₂	h ₂	t
FFD-25	0.1 / 0.5 / 1.0	Type S	25	6	13	3	42	34	21	6.2	16	4	4
FFD-28	0.1 / 0.5 / 1.0	Type S	28	8	13	3	44	36	24	8.2	16	4	4
FFD-30	0.1 / 0.5 / 1.0 / 1.5	Type S	30	10	13	3	46	38	26	10.2	16	4	4
FFD-25	1.0 / 1.5 / 2.0	Type W	25	6	19	3	42	34	21	6.2	22	4	4
FFD-28	1.0 / 1.5 / 2.0	Type W	28	8	19	3	44	36	24	8.2	22	4	4
FFD-30	1.5 / 2.0 / 2.5 / 3.0	Type W	30	10	19	3	46	38	26	10.2	22	4	4

¹ Damping clockwise or anti-clockwise.

Material: Polycarbonate plastic
 Operating temperature range: -10 °C to 60 °C
 Rotational speed max.: 30 rpm
 Cycle rate max.: 13 cycles per minute
 Recommended shaft details: \varnothing +0 / -0.03

Ordering Example

FFD-25-FS-L-102
 Friction Damper _____
 Body \varnothing _____
 Mounting Style (Flange = F, Standard = S) _____
 Damping Option (S or W) _____
 Damping Direction (right = R, left = L) _____
 Damping Torque see chart _____

Damping Torque

102 = 0.1 Nm
 502 = 0.5 Nm
 103 = 1.0 Nm
 153 = 1.5 Nm
 203 = 2.0 Nm
 253 = 2.5 Nm
 303 = 3.0 Nm

FYT-H1 and FYN-H1

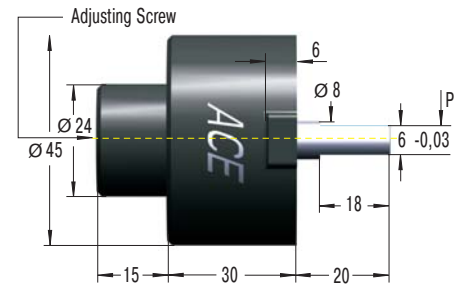
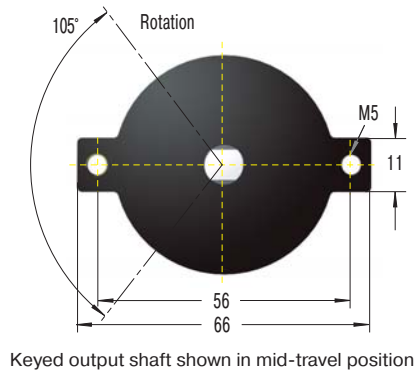
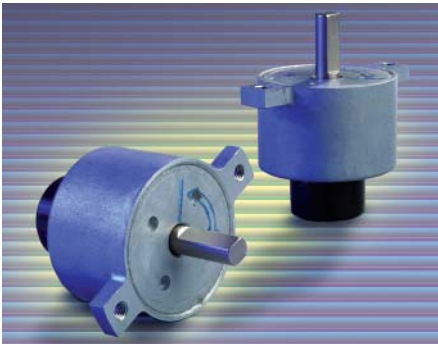

Model Adjustable

Bidirectional Damping	Right-Hand Damping (clockwise)	Left-Hand Damping (anti-clockwise)	Damping Torque Nm (adjustable)
FYT-H1	FYN-H1-R	FYN-H1-L	2...10

Material: Zinc diecast, steel shaft
 Operating temperature range: -5 °C to 50 °C
 Max. rotation angle: 105°
 Return Damping Torque: 0.5 Nm
 Maximum side load: 50 N
 Weight: 0.24 kg

A play of approx. 5° can occur at the beginning of movement.
 Do not use damper as final end stop.
 Fit external mechanical stops at each end of travel.

FYT-LA3 and FYN-LA3

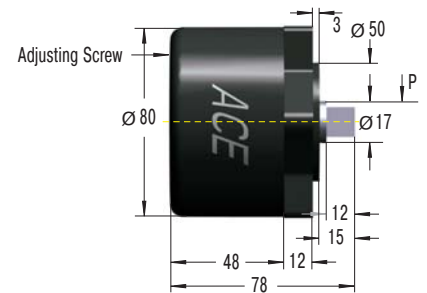
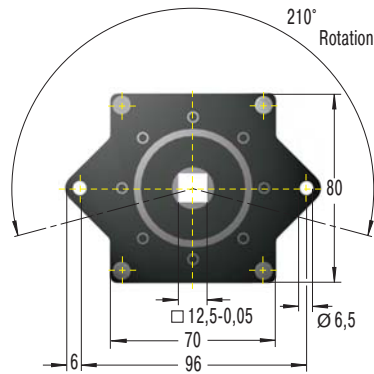
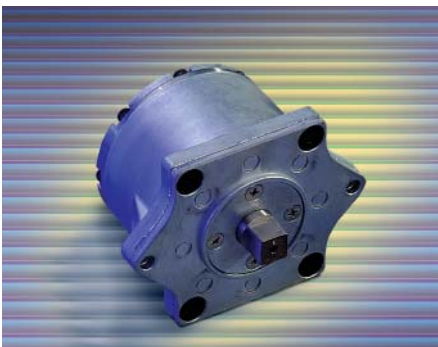

Keyed output shaft shown in mid-travel position

Model Adjustable

Bidirectional Damping	Right-Hand Damping (clockwise)	Left-Hand Damping (anti-clockwise)	Damping Torque Nm (adjustable)
FYT-LA3	FYN-LA3-R	FYN-LA3-L	4...40

Material: Zinc diecast, steel shaft
 Operating temperature range: -5 °C to 50 °C
 Max. rotation angle: 210°
 Return Damping Torque: 4 Nm
 Maximum side load: 200 N
 Weight: 1.75 kg

A play of approx. 5° can occur at the beginning of movement.
 Do not use damper as final end stop.
 Fit external mechanical stops at each end of travel.

FDT-47 to 70

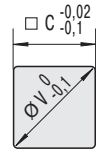
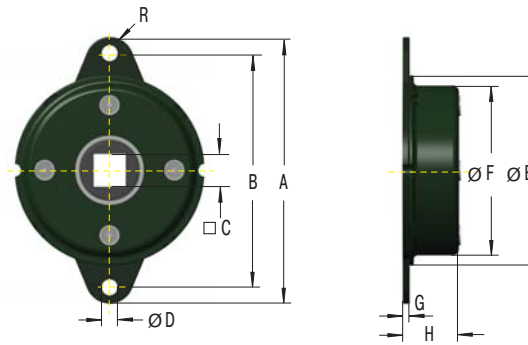

Recommended Drive Shaft Size

Damping in both Directions of Rotation

Type	Damping Torque Nm (at 20 rpm, 23 °C)	Dimensions									
		A	B	C	D	E	F	G	H	R	V
FDT-47	2.0 +/- 0.3	65	56	8	4.5	47	42.8	1.6	10.3	4.5	10
FDT-57	4.7 +/- 0.5	79	68	10	5.5	57	52.4	1.6	11.2	5.5	13
FDT-63	6.7 +/- 0.7	89	76	12.5	6.5	63	58.6	1.6	11.3	6.5	17
FDT-70	8.7 +/- 0.8	95	82	12.5	6.5	70	65.4	1.6	11.3	6.5	17

Material: Steel. Output shaft sleeve: Nylon
 Operating temperature range: -10 °C to 50 °C
 Rotational speed max.: 50 rpm
 Cycle rate max.: 12 cycles per minute
 Weight max.: 0.11 kg

FDT (at 23 °C)

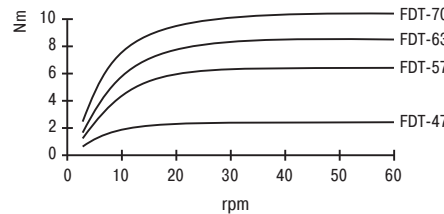

FDT (at 20 rpm)

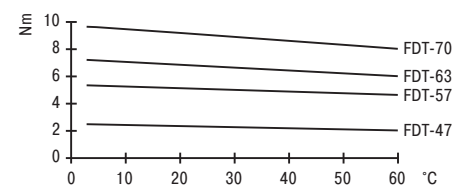

There is no support for the output shaft within the damper structure. External support must be provided for the shaft.

FDN-47 to 70

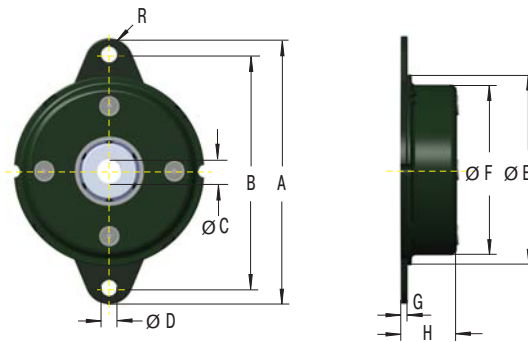

Right-Hand Damping (clockwise)	Left-Hand Damping (anti-clockwise)	Damping Torque Nm (at 20 rpm, 23 °C)	Dimensions								
			A	B	C	D	E	F	G	H	R
FDN-47-R	FDN-47-L	2.0 +/- 0.3	65	56	6	4.5	47	42.8	1.6	10.3	4.5
FDN-57-R	FDN-57-L	5.5 +/- 0.3	79	68	10	5.5	57	52.4	1.6	14	5.5
FDN-63-R	FDN-63-L	8.5 +/- 0.8	89	76	10	6.5	63	58.6	1.6	13.9	6.5
FDN-70-R	FDN-70-L	10.0 +/- 1.0	95	82	10	6.5	70	65.4	1.6	13	6.5

Material: Steel. Output shaft sleeve: Nylon
 Operating temperature range: -10 °C to 50 °C
 Rotational speed max.: 50 rpm
 Cycle rate max.: 12 cycles per minute
 Weight max.: 0.12 kg

There is no support for the output shaft within the damper structure. External support must be provided for the shaft.

Recommended shaft details:

for FDN-47: $\text{Ø } 6^{+0}_{-0,03}$

for FDN-57 to FDN-70: $\text{Ø } 10^{+0}_{-0,03}$

Hardness > HRC55, surface smoothness $R_z < 1 \mu\text{m}$

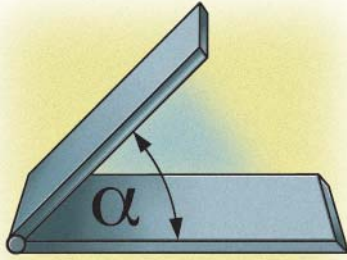

Closing Torque T
 $T = L / 2 \cdot m \cdot g \cdot \cos \alpha \quad \text{Ncm}$

Note: for a uniform lid assume centre of gravity is at distance L/2 from pivot.

Calculation of Rotary Damper for a Lid

- m Mass of lid (kg)
- L Length of lid from pivot (cm)
- n Rotation speed (r.p.m.)
- g Acceleration due to gravity (= 9.81)

Calculation Steps

- 1) Calculate max. torque damper will be exposed to (with example shown max. torque is at $\alpha = 0$).
- 2) Decide upon rotation speed desired.
- 3) Choose a rotary damper from catalogue that can handle the torque calculated above.
- 4) With the aid of the damper performance curves, check if the r.p.m. given at your torque corresponds to the desired closing speed of the lid.
- 5) If the r.p.m. is too high – choose a damper with a higher torque rating.
 If the r.p.m. is too low – choose a damper with a lower torque rating.

Mountings to Avoid

The output shaft should **not** be exposed to side loading.

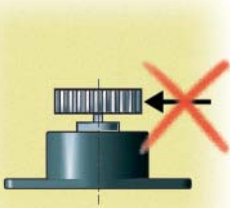

Side loading

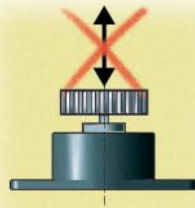

End loading

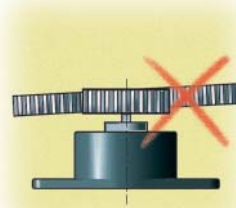

Angular offset

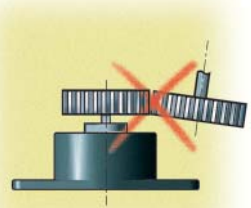

Misalignment

Toothed Rack M0.5, M0.6, M0.8, M1.0

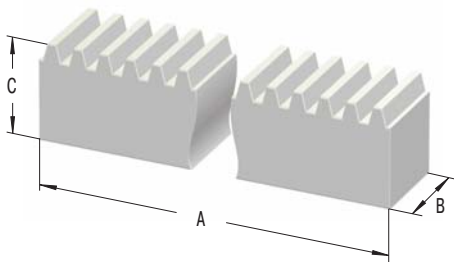

Toothed Rack M0.8P

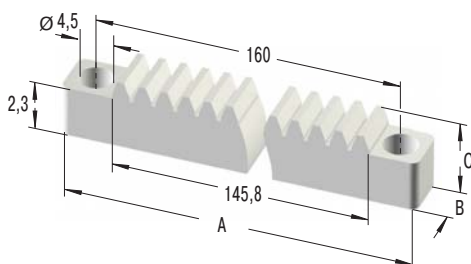

Damping Direction

right hand damping = damping action in clockwise direction when looking onto the output shaft

Accessories

Toothed plastic rack with modules 0.5 to 1 available.

Models Available

Toothed Rack	A	B	C	Model
M0.5	250	4	4,5	rigid, milled
M0.6	250	4	6	rigid, milled
M0.8	250	6	8	rigid, milled
M0.8P	170	8	4,1	flexible, milled
M1.0	250	9	9	rigid, milled
M1.0	500	10	10	rigid, milled

Metal racks available on request.

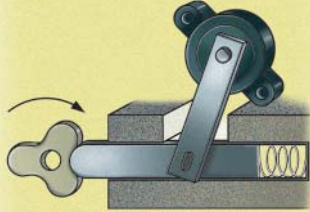

Even rhythm

ACE rotary dampers ensure the quiet shuffling of playing cards.

Software controlled playing card shuffling machines such as this one are used throughout the world and are equipped with the **FRT-G2-101-G1** type rotary dampers. Maintenance-free and ready to install. Before inserting the set of cards, you can ensure the quiet stopping of the plastic wedge in the equipment when it is driven upwards. The dampers can be applied to suit your requirements; clockwise, anticlockwise or in both directions; and they are just as reliable as the open and close slides in high quality DVD or CD players.

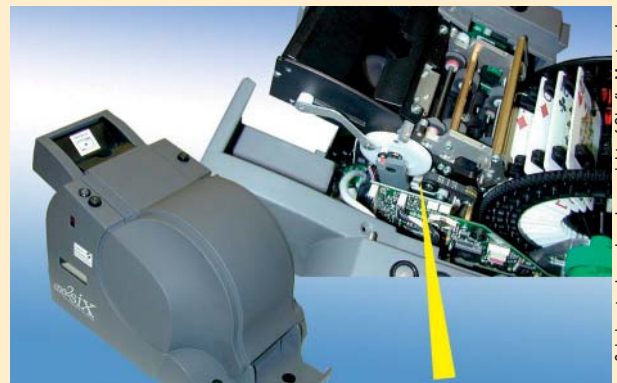

one2six is a trademark and copyright of Shuffle Master, Inc.

Playing cards are shuffled simply and quietly

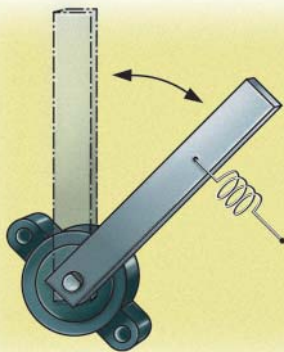

Damping lever motions

ACE rotary dampers protect the keyboard.

To provide long term protection in arduous and often dirty industrial applications (and also to protect against unauthorised access) the machine keyboard is installed in a lockable and pivoted housing cabinet.

ACE rotary dampers type **FRN-F1** were installed on the pivot axis to provide a smooth controlled motion to the keyboard as it is pulled down into its operating position. The damper also prevents overloading the hinge system and prevents damage to the keyboard, the housing cabinet and the hinges.



Pivoted machine keyboard