

Hydraulic dampers from ACE are maintenance-free, self-contained and sealed units. They are available with body diameters from 12 mm up to 70 mm and with stroke lengths of up to 800 mm. As standard they are supplied as double acting dampers but a single acting version is also available. The single acting version is controllable in one direction only, with free flow in the opposite direction. The travel speed is adjustable and remains constant throughout the stroke. **The new adjustment segment on the piston makes sensitive speed adjustment easy.** ACE's hydraulic dampers sport the sleek design of our gas springs. **The body has a black powder coated finish and the piston rod has a special hard ceramic coating which provides an exceptionally long lifetime and excellent corrosion protection.** A wide range of screw on mounting accessories make them very versatile and easy to install. Typical applications include machine guards and lids, fire safety flaps and doors, damping oscillations of suspended loads (Power and Free Systems) etc.

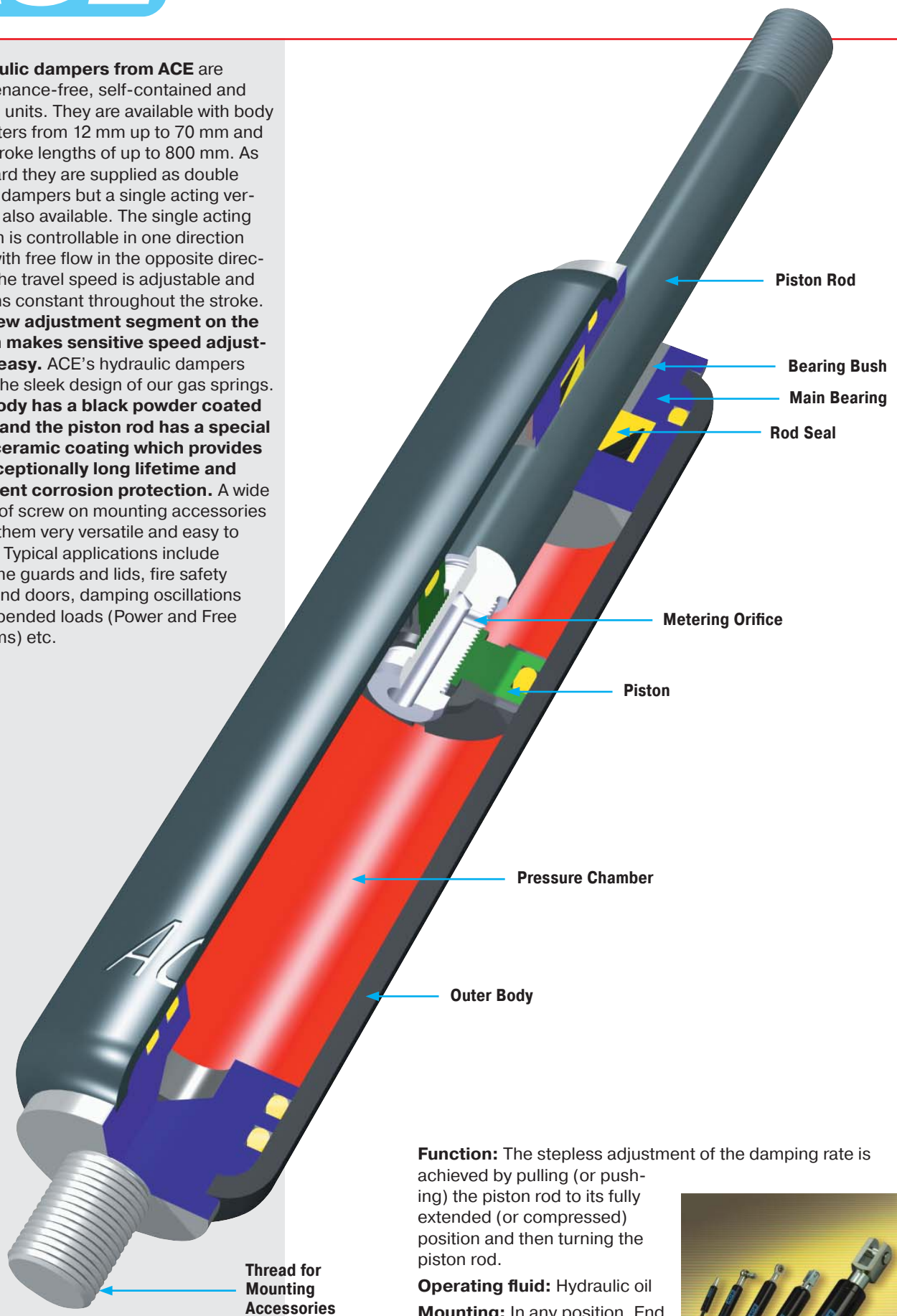

Function: The stepless adjustment of the damping rate is achieved by pulling (or pushing) the piston rod to its fully extended (or compressed) position and then turning the piston rod.

Operating fluid: Hydraulic oil

Mounting: In any position. End fittings must be positively secured to prevent unscrewing.

Operating temperature range: -20 °C to 80 °C

On request: Special lengths, alternative seals and end fittings.



End Fitting

Standard Dimensions

End Fitting

A3,5

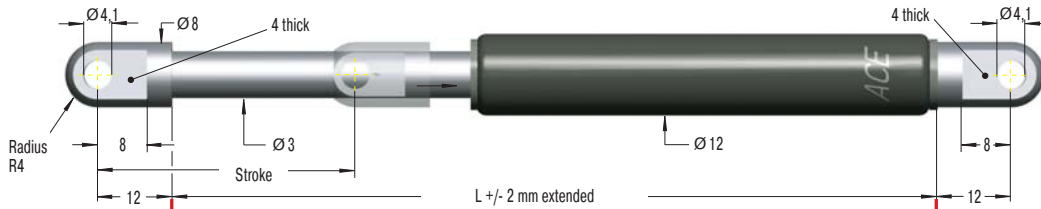

Eye
A3,5-M5

B3,5

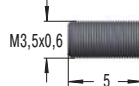

Dimensions

Type	Stroke mm	L extended	¹ Max. Compression Force N
HB-12-10	10	55	180
HB-12-20	20	75	180
HB-12-30	30	95	180
HB-12-40	40	115	180
HB-12-50	50	135	180
HB-12-60	60	155	180
HB-12-70	70	175	180
HB-12-80	80	195	150

¹ Max. extension force for all stroke lengths 180 N.

Stud Thread
B3,5-M5

C3,5

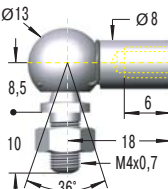

Angle Ball Joint
C3,5-M5
(max. force 225 N)

D3,5

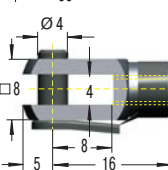

Clevis Fork
D3,5-M5
(max. force 225 N)

E3,5

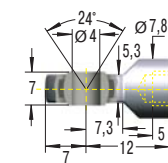

Swivel Eye
E3,5-M5
(max. force 225 N)

G3,5

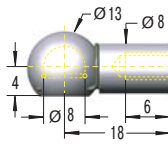

Ball Socket
G3,5-M5
(max. force 225 N)

Rod Shroud
W3,5-12

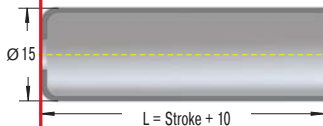

Ordering Example

Type (Hydraulic Damper) _____
 Body Ø (12 mm) _____
 Stroke (30 mm) _____
 Piston Rod End Fitting A3,5 _____
 Body End Fitting C3,5-M5 _____
 Damping Direction (M = out stroke only) _____

HB-12-30-AC-M

Damping Options

M = Damping on out stroke only
 N = Damping on in stroke only
 P = Damping in both directions
 X = Special model suffix

The end fittings are interchangeable and must be positively secured by the customer to prevent unscrewing (i.e. Loctite). For mounting accessories see page 155.

HB-12

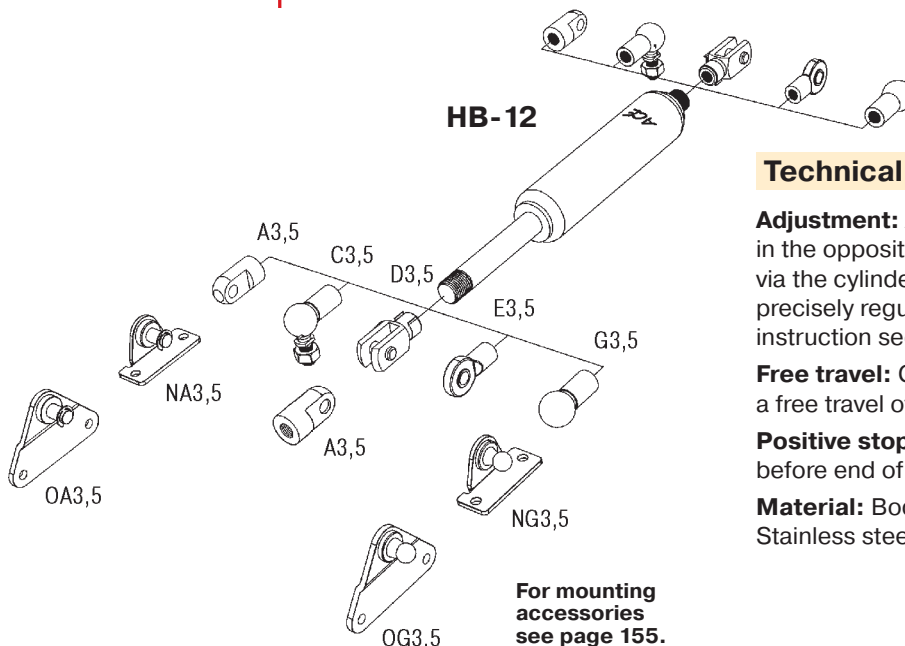

For mounting accessories see page 155.

Technical Data

Adjustment: Adjustment of the damping rate is handled, in the opposite way to the dampers HB-15 to HB-70, via the cylinder stud thread. The damping force can be precisely regulated by using a screwdriver (adjustment instruction see page 129).

Free travel: Construction of standard damper results in a free travel of approx. 21 % of stroke.

Positive stop: Provide mechanical stops 1 to 1.5 mm before end of each stroke direction.

Material: Body: Black powder coated steel. Piston rod: Stainless steel (1.4305). End fittings: Zinc plated steel.

End Fitting

Standard Dimensions

End Fitting

End Fitting Options:

- A8:** Eye A8
- B8:** Stud Thread B8
- C8:** Angle Ball Joint C8 (max. force 1 200 N)
- D8:** Clevis Fork D8 (max. force 3 000 N)
- E8:** Swivel Eye E8 (max. force 3 000 N)
- G8:** Ball Socket G8 (max. force 1 200 N)

Dimensions:

Type	Stroke mm	L extended	¹ Max. Compression Force N
HB-22-50	50	150	1 800
HB-22-100	100	250	1 800
HB-22-150	150	350	1 800
HB-22-200	200	450	1 000
HB-22-250	250	550	1 000

¹ Max. extension force for all stroke lengths 1 800 N.

Ordering Example: **HB-22-150-DD-M**

Type (Hydraulic Damper) _____
 Body Ø (22 mm) _____
 Stroke (150 mm) _____
 Piston Rod End Fitting D8 _____
 Body End Fitting D8 _____
 Damping Direction (M = out stroke only) _____

Damping Options:
 M = Damping on out stroke only
 N = Damping on in stroke only
 P = Damping in both directions
 X = Special model suffix

The end fittings are interchangeable and must be positively secured by the customer to prevent unscrewing (i.e. Loctite). For mounting accessories see page 156.

Rod Shroud W8-22

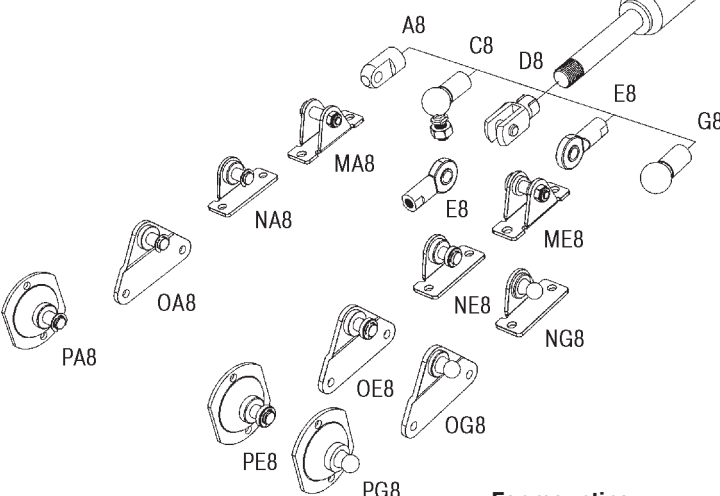
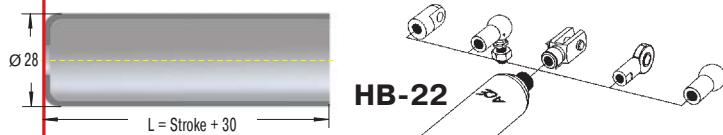

For mounting accessories see page 156.

Technical Data

Mounting: In any position. End fittings must be positively secured to prevent unscrewing.

Adjustment: Adjustment of the damping rate is achieved by pulling (or pushing) the piston rod to its fully extended (or compressed) position. Whilst still pulling the piston rod turn it clockwise to increase damping and anti-clockwise to decrease damping. If the resistance increases noticeably, stop adjusting to avoid damage. The adjustment can add a max. of 6 mm to the L dim. shown (adjustment instruction see page 129).

Free travel: Construction of standard damper results in a free travel of approx. 20 % of stroke.

Positive Stop: Provide mechanical stops 1 to 1.5 mm before end of each stroke direction.

Material: Body: Black powder coated steel. Piston rod: Ceramic coated steel. End fittings: Zinc plated steel.

Separator piston: Available as a special option to remove free travel. Also provides extension force of max. 100 N. Dimension L = 2.38 x stroke + 55 mm. Part number: add suffix -T.

On request: Special lengths, alternative seals and end fittings.

End Fitting

Standard Dimensions

End Fitting

End Fitting A8 Eye A8

End Fitting Stud Thread B8

End Fitting Angle Ball Joint C8 (max. force 1 200 N)

End Fitting Clevis Fork D8 (max. force 3 000 N)

End Fitting Swivel Eye E8 (max. force 3 000 N)

End Fitting Ball Socket G8 (max. force 1 200 N)

Dimensions

Type	Stroke mm	L extended	¹ Max. Compression Force N
HB-28-100	100	260	3 000
HB-28-150	150	360	3 000
HB-28-200	200	460	3 000
HB-28-250	250	560	3 000
HB-28-300	300	660	2 500
HB-28-350	350	760	2 000
HB-28-400	400	860	1 500
HB-28-500	500	1 060	1 000

¹ Max. extension force for all stroke lengths 3 000 N.

Ordering Example **HB-28-150-DD-M**

Type (Hydraulic Damper) _____

Body Ø (28 mm) _____

Stroke (150 mm) _____

Piston Rod End Fitting D8 _____

Body End Fitting D8 _____

Damping Direction (M = out stroke only) _____

Damping Options

M = Damping on out stroke only
 N = Damping on in stroke only
 P = Damping in both directions
 X = Special model suffix

The end fittings are interchangeable and must be positively secured by the customer to prevent unscrewing (i. e. Loctite). For mounting accessories see page 156.

Rod Shroud W8-28

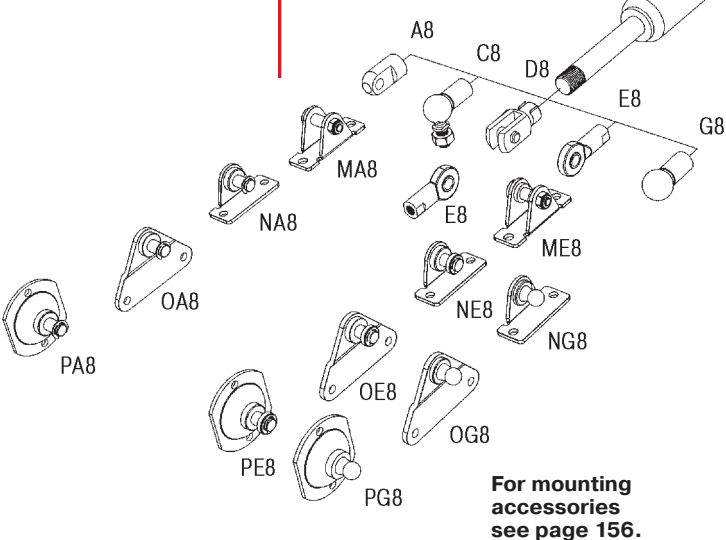
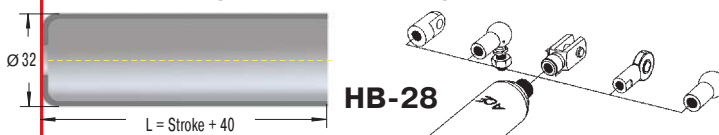

Technical Data

Mounting: In any position. End fittings must be positively secured to prevent unscrewing.

Adjustment: Adjustment of the damping rate is achieved by pulling (or pushing) the piston rod to its fully extended (or compressed) position. Whilst still pulling the piston rod turn it clockwise to increase damping and anti-clockwise to decrease damping. If the resistance increases noticeably, stop adjusting to avoid damage. The adjustment can add a max. of 6 mm to the L dim. shown (adjustment instruction see page 129).

Free travel: Construction of standard damper results in a free travel of approx. 20 % of stroke.

Positive Stop: Provide mechanical stops 1 to 1.5 mm before end of each stroke direction.

Material: Body: Black powder coated steel. Piston rod: Ceramic coated steel. End fittings: Zinc plated steel.

Separator piston: Available as a special option to remove free travel. Also provides extension force of max. 100 N. Dimension L = 2.35 x stroke + 60 mm. Part number: add suffix -T.

On request: Special lengths, alternative seals and end fittings.

Issue 4.2009 Specifications subject to change

End Fitting

Standard Dimensions

End Fitting

A14 Eye **A14**

B14 Stud Thread **B14**

C14 Angle Ball Joint **C14**
(max. force 3 200 N)

D14 Clevis Fork **D14**
(max. force 10 000 N)

E14 Swivel Eye **E14**
(max. force 10 000 N)

Dimensions

Type	Stroke mm	L extended	¹ Max. Compression Force N
HB-40-100	100	275	10 000
HB-40-150	150	375	10 000
HB-40-200	200	475	10 000
HB-40-300	300	675	10 000
HB-40-400	400	875	8 000
HB-40-500	500	1 075	6 000
HB-40-600	600	1 275	4 000
HB-40-700	700	1 475	3 000
HB-40-800	800	1 675	3 000

¹ Max. extension force for all stroke lengths 10 000 N.

Ordering Example **HB-40-300-EE-N**

Type (Hydraulic Damper) _____
 Body Ø (40 mm) _____
 Stroke (300 mm) _____
 Piston Rod End Fitting E14 _____
 Body End Fitting E14 _____
 Damping Direction (N = in stroke only) _____

Damping Options
 M = Damping on out stroke only
 N = Damping on in stroke only
 P = Damping in both directions
 X = Special model suffix

The end fittings are interchangeable and must be positively secured by the customer to prevent unscrewing (i.e. Loctite). For mounting accessories see page 157.

Rod Shroud W14-40

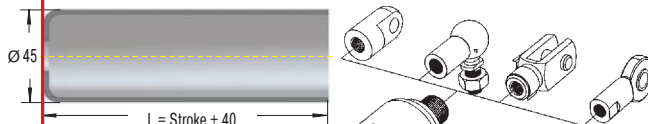

Technical Data

Mounting: In any position. End fittings must be positively secured to prevent unscrewing.

Adjustment: Adjustment of the damping rate is achieved by pulling (or pushing) the piston rod to its fully extended (or compressed) position. Whilst still pulling the piston rod turn it clockwise to increase damping and anti-clockwise to decrease damping. If the resistance increases noticeably, stop adjusting to avoid damage. The adjustment can add a max. of 6 mm to the L dim. shown (adjustment instruction see page 129).

Free travel: Construction of standard damper results in a free travel of approx. 20 % of stroke.

Positive stop: Provide mechanical stops 1 to 1.5 mm before end of each stroke direction.

Material: Body: Black powder coated steel. Piston rod: Ceramic coated steel. End fittings: Zinc plated steel.

Separator piston: Available as a special option to remove free travel. Also provides extension force of max. 200 N. Dimension L = 2.32 x stroke + 82 mm. Part number: add suffix -T.

On request: Special lengths, alternative seals and end fittings.

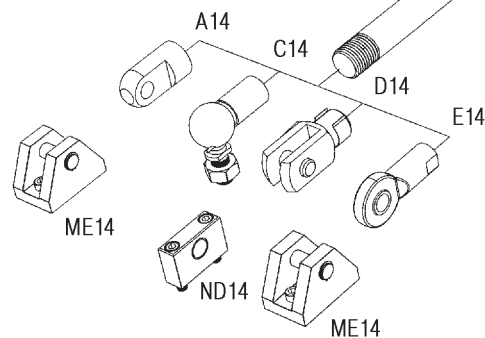

For mounting accessories see page 157.

HB-40

End Fitting

Standard Dimensions

End Fitting

B24

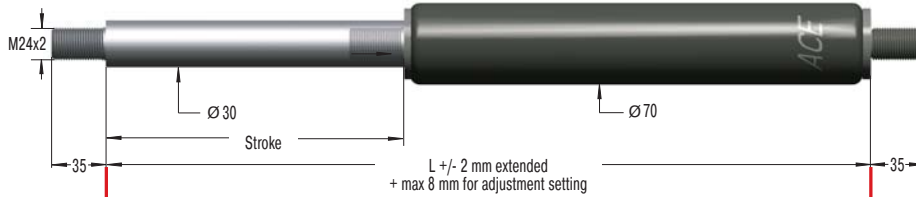

Stud Thread B24

D24

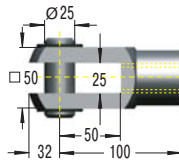

Clevis Fork D24
(max. force 50 000 N)

E24

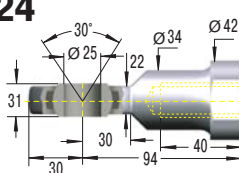

Swivel Eye E24
(max. force 50 000 N)

Dimensions

Type	Stroke mm	L extended	¹ Max. Compression Force N
HB-70-100	100	320	50 000
HB-70-200	200	520	50 000
HB-70-300	300	720	50 000
HB-70-400	400	920	30 300
HB-70-500	500	1 120	21 600
HB-70-600	600	1 320	16 200
HB-70-700	700	1 520	12 600
HB-70-800	800	1 720	10 100

¹ Max. extension force for all stroke lengths 50 000 N.

Ordering Example

HB-70-300-EE-N

Type (Hydraulic Damper) _____
 Body Ø (70 mm) _____
 Stroke (300 mm) _____
 Piston Rod End Fitting E24 _____
 Body End Fitting E24 _____
 Damping Direction (N = in stroke only) _____

Damping Options

M = Damping on out stroke only
 N = Damping on in stroke only
 P = Damping in both directions
 X = Special model suffix

The end fittings are interchangeable and must be positively secured by the customer to prevent unscrewing (i. e. Loctite). For mounting accessories see page 157.

Rod Shroud
W24-70

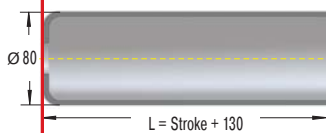

Technical Data

Mounting: In any position. End fittings must be positively secured to prevent unscrewing.

Adjustment: Adjustment of the damping rate is achieved by pulling (or pushing) the piston rod to its fully extended (or compressed) position. Whilst still pulling the piston rod turn it clockwise to increase damping and anti-clockwise to decrease damping. If the resistance increases noticeably, stop adjusting to avoid damage. The adjustment can add a max. of 8 mm to the L dim. shown (adjustment instruction see page 129).

Free travel: Construction of standard damper results in a free travel of approx. 20 % of stroke.

Positive stop: Provide mechanical stops 5 to 6 mm before end of each stroke direction.

Material: Body: Black powder coated steel or zinc plated steel. Piston rod: Hard chrome plated. End fittings: Zinc plated steel.

Separator piston: Available as a special option to remove free travel. Also provides extension force of max. 250 N. Increases dimension L + 150 mm. Part number: add suffix -T.

On request: Special lengths, alternative seals and end fittings.

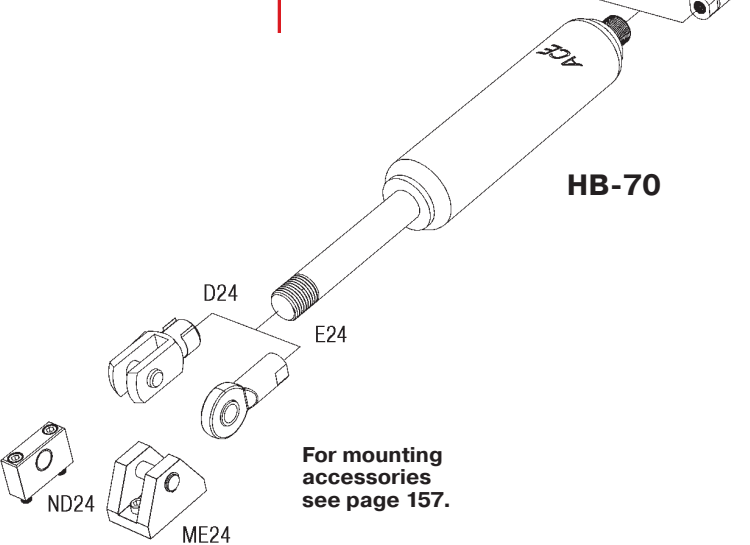

For mounting accessories see page 157.

Adjustment Instructions for HB-15 to HB-70 and HBS-28 to HBS-70



Adjustment only possible when piston rod is **fully** extended or **fully** compressed.

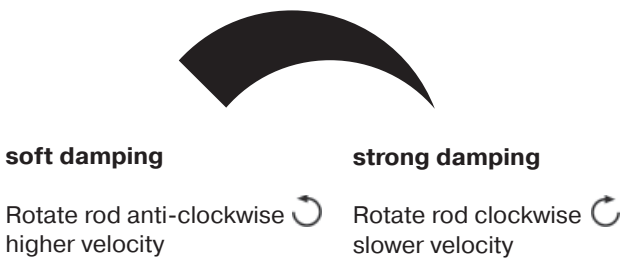

1. Hold outer body.
2. a) When piston rod is fully extended:
Adjust damping by turning the piston rod as shown in the picture. Whilst rotating, pull the piston rod gently, to ensure the adjuster locates in the end cap.
b) When the piston rod is fully compressed:
Adjust the damping by turning the piston rod as shown in the picture. Whilst rotating, push the piston rod gently, to ensure the adjuster locates in the end cap.
3. When resistance is felt when rotating the piston rod, stop turning. You will be at the end of the adjustment.
NOTE: Do not rotate piston rod too quickly as damage could occur.
4. Check the damping, if required repeat step 1 to 3.
5. On all versions with a separator piston (type "T") adjustment is only possible when the piston rod is extended (adjustment 2a).

Adjustment Instructions for HB-12

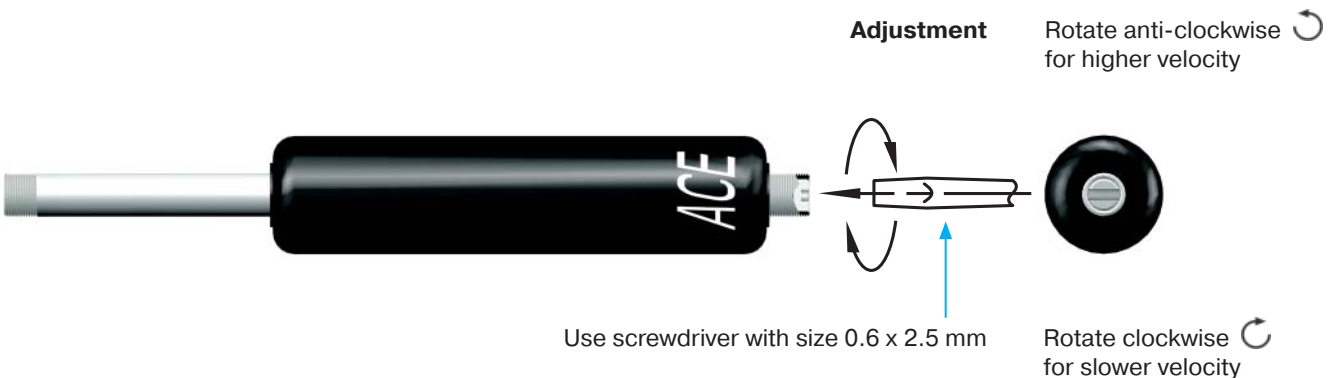

Standard Dimensions TD-28

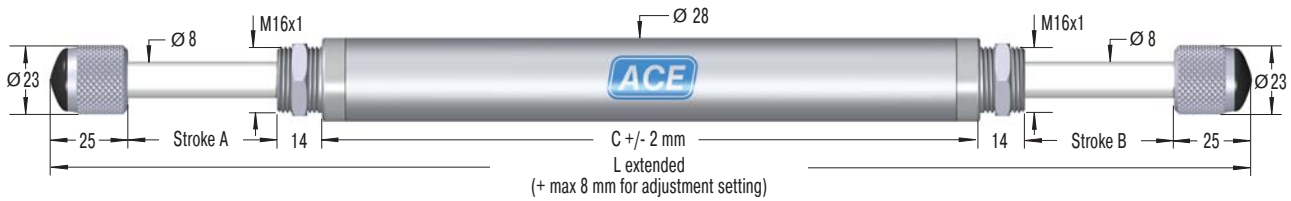

Ordering Example

Type (Door Damper) _____
 Body Ø (28 mm) _____
 Stroke A (50 mm) _____
 Stroke B (50 mm) _____

TD-28-50-50

Return Type

F = automatic return with return spring
 D = without return spring. When one piston is pushed in, the piston rod at the other end is pushed out (thus the damper must be impacted from alternate ends to sequence correctly).

Dimensions and Capacity Chart

Type	Stroke A mm	Stroke B mm	C	L max	Max. Impact Mass kg	Max. Damping Force Q N	Max. Energy Capacity		Return Type	Adjustment
							W ₃ Nm/Cycle	Max. Return Force N		
TD-28-50-50	50	50	220	402	150	1 550	75	30	F	Tooth Type
TD-28-70-70	70	70	260	482	200	1 500	70	30	F	Tooth Type
TD-28-100-100	100	100	220	502	250	1 500	80	40	F	Tooth Type
TD-28-120-120	120	120	208	410	250	3 800	165	0	D	Tooth Type

Standard Dimensions TDE-28

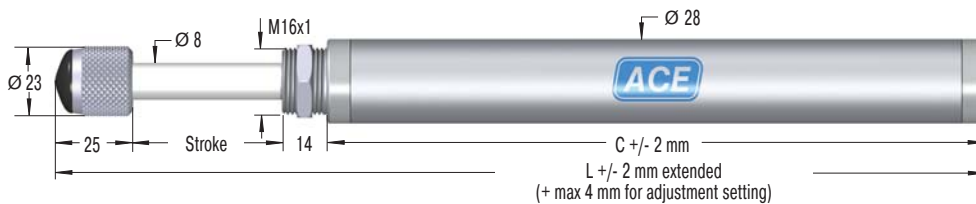

Ordering Example

Type (Door Damper) _____
 Body Ø (28 mm) _____
 Stroke (50 mm) _____

TDE-28-50

Dimensions and Capacity Chart

Type	Stroke mm	C	L max	Max. Impact Mass kg	Max. Damping Force Q N	Max. Energy Capacity		Max. Return Force N
						W ₃ Nm/Cycle		
TDE-28-50	50	130	221	4 000	2 400	80	30	
TDE-28-70	70	158	269	5 600	2 400	112	30	
TDE-28-100	100	193	333	8 000	2 400	160	30	
TDE-28-120	120	214	373	7 000	2 400	190	40	

Technical Data

ACE door dampers are single ended or double ended adjustable hydraulic shock absorbers.

Application areas: Cushioning of elevator doors, automatic and sliding doors and similar applications.

Adjustment: Pull the piston rod fully out and turn the knurled rod end button. This allows the damping to be separately adjusted for each side. As a result of the adjustment mechanism the overall length L can be increased by up to 4 mm.

Operating temperature range: -20 °C to 80 °C

Impact velocity range v: 0.1 to 2 m/s

Strokes per minute: max. 10

Material: Piston rod: hard chrome plated steel. Cylinder body: zinc plated steel.

On request: With different deceleration characteristics, special stroke lengths, special seals etc.

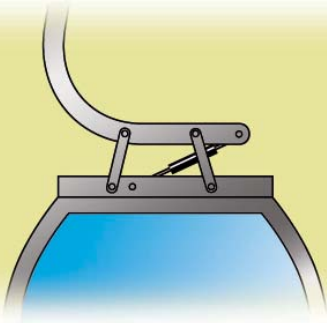

Swinging movements cushioned by hydraulic dampers

Passengers always feel the swinging movement involved when cable cars arrive at the ski station.

Maintenance-free **hydraulic dampers** type **HB-40-300-EE-X-P** cushion these movements perfectly. Designers of the cable cars, connected by means of an articulated joint via a four-point frame and connection guide to the suspension rod, profit from the ability of the adjustable dampers to absorb compressive forces of up to 10 000 N on either side.



Hydraulic dampers for added convenience when operating cable cars

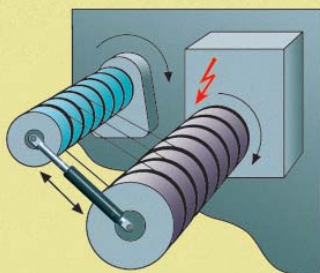

Precise unreeling

Hydraulic dampers bring the sled movement of this textile machine to a gentle stop.

At the turning point of 130 kg reeling spools, a sled should move up and down smoothly without causing a collision at the end of stroke position. The solution was provided by the hydraulic damper **DVC-32-100**. A self-contained sealed unit, ready to install and maintenance-free these units are ideal for precise control of speeds in both directions of travel. The travel speed is maintained throughout the entire stroke and can be independently adjusted in each direction of travel. Thanks to their compact design and wide choice of mounting accessories, these dampers could be easily integrated into this machine.

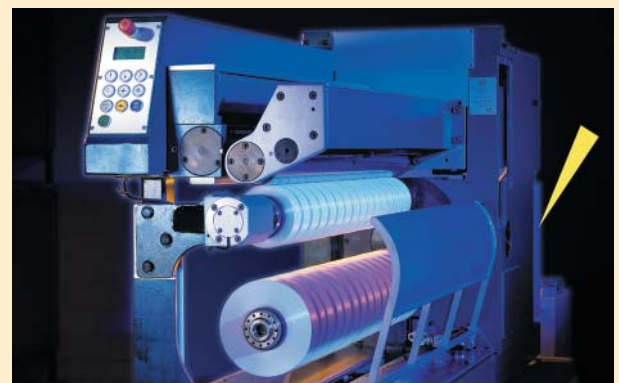

Textile machine unreels threads even better