

Discrete type for different piping conditions

VSH/VSU/VSU/VSU Series

- Nozzle diameter: $\varnothing 0.5$, $\varnothing 0.7$, $\varnothing 1.0$, $\varnothing 1.2$, $\varnothing 1.5$, $\varnothing 2.0$
Different performance and shape are available to match different conditions.



Features

- This ejector can be used to transport workpieces (objects) by changing compressed air to a vacuum and using combined with a vacuum pad.
- Different performance and shape are available to match different conditions.

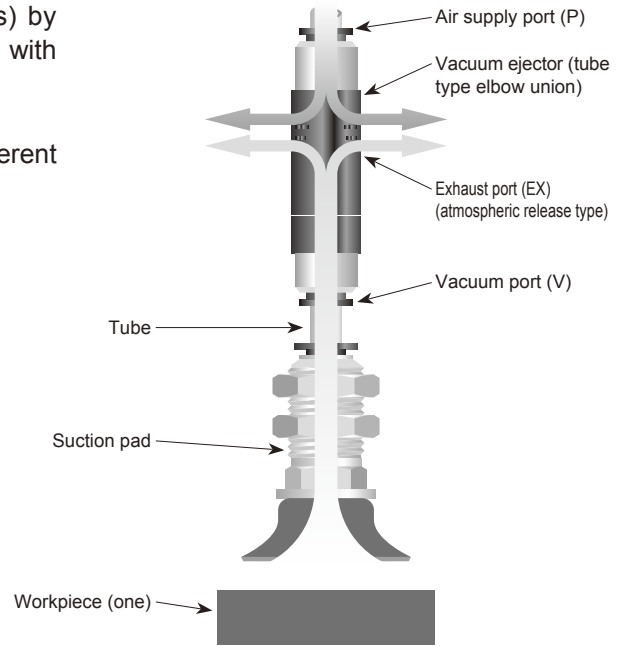

Common specifications

Descriptions	VSH/VSU/VSU/VSU
Working fluid	Compressed air
Working pressure range MPa	0.15 to 0.7
Ambient temperature range °C	0 to 60

Square shaped/vacuum switch mounted type (VSB) / mechanical vacuum switch specifications

Descriptions	Mechanical vacuum switch
Pressure detection method	Diaphragm - micro switch
Working fluid	Low vacuum/air
Ambient temperature range °C	0 to 60 (no freezing)
Rated electricity	3A 250V
Set pressure range kPa	-20 to -66
Precision kPa	± 5
Hysteresis kPa	22 or less
Setting pressure when shipping kPa	-53

How to order * Refer to the tables of dimensions on pages 18 to 28.

VS H - H 07 - 10 8A J

A Shape

B Vacuum characteristics

C Nozzle diameter

D Vacuum port (V)

E Air supply port (P)

F Additional

Symbol	Descriptions
A Shape	
H	Solenoid valve directly mounted type
U	Tube type
C	Pad directly mounted type
B	Square shaped
B Vacuum characteristics	
H	High vacuum/medium flow type
L	Medium vacuum/large flow rate type
E	High vacuum/small flow rate type
C Nozzle diameter	
05	ø0.5
07	ø0.7
10	ø1.0
12	ø1.2
15	ø1.5
20	ø2.0
D Vacuum port (V)	
4	ø4 push-in joint
6	ø6 push-in joint
8	ø8 push-in joint
10	ø10 push-in joint
12	ø12 push-in joint
M5	M5 x 0.5
6A	R1/8
8A	R1/4
10A	R3/8
E Air supply port (P)	
4	ø4 push-in joint
6	ø6 push-in joint
6L	ø6 push-in joint elbow
8	ø8 push-in joint
8L	ø8 push-in joint elbow
10	ø10 push-in joint
10L	ø10 push-in joint elbow
12	ø12 push-in joint
M5	M5 x 0.5
6A	R1/8
8A	R1/4
F Additional	
S	Atmospheric release with silencer (VSH/VSU/VSC)
J	Common exhaust (VSH/VSU/VSC)
V	With mechanical vacuum switch (VSB)
Blank	Without pressure switch for vacuum (VSB)

Ejector system

VSU

VSH-VSU
VSB-VSC

VSG

VSK
VSKM

VSJ
VSJM

VSX
VSXM

VSQ

VSZM

VSH/VSU/VSB/VSC Series

Vacuum characteristics

Supply pressure - ultimate vacuum, suction flow, air consumption flow

● VSH- Γ 05, VSB- Γ 05

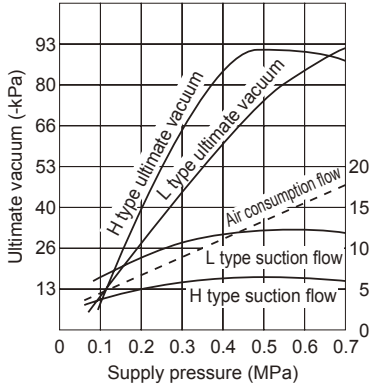

● VSH-*07, VSB-*07, VSC-*07

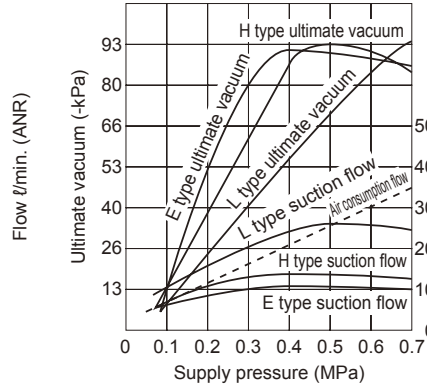

● VSH-*10, VSB-*10, VSC-*10

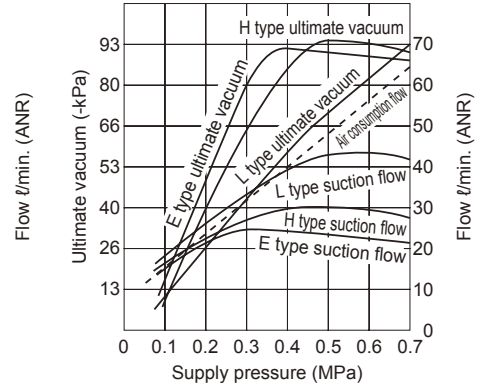

● VSH-H12, VSB-H12, VSC- Γ 12

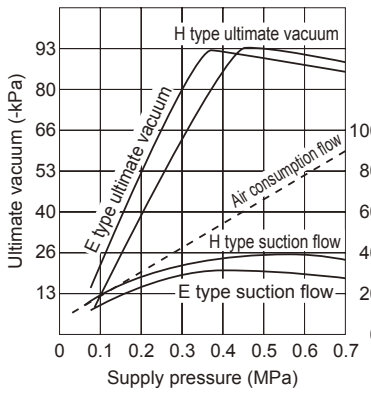

● VSH-*15, VSC-*15

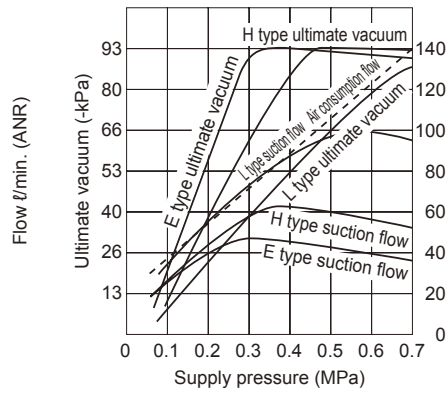

● VSH-*20, VSC-*20

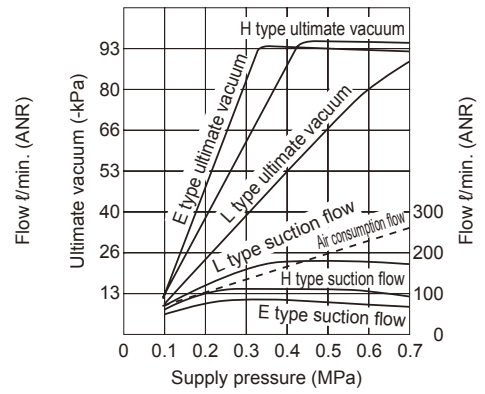

● VSU- Γ 05, VSC- Γ 05

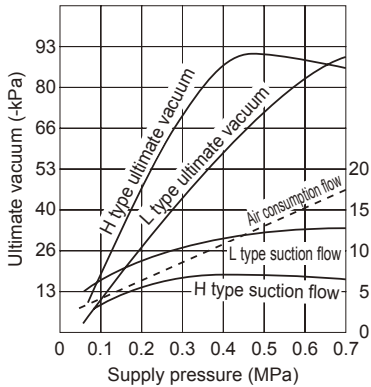

● VSU-*07

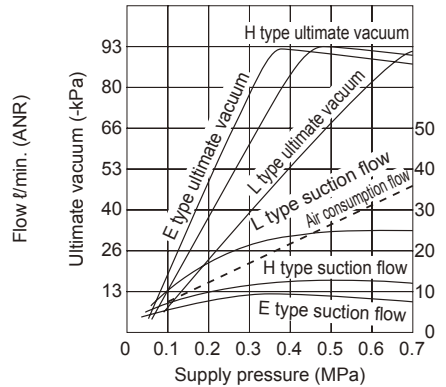

Vacuum characteristics

(References) Ultimate vacuum time (supply pressure H type: 0.5MPa, L type: 0.5MPa, E type: 0.3 to 0.5MPa)

* Values differ with vacuum system piping shape, etc., so use these valves for reference.

● VSH-H05, VSB-H05

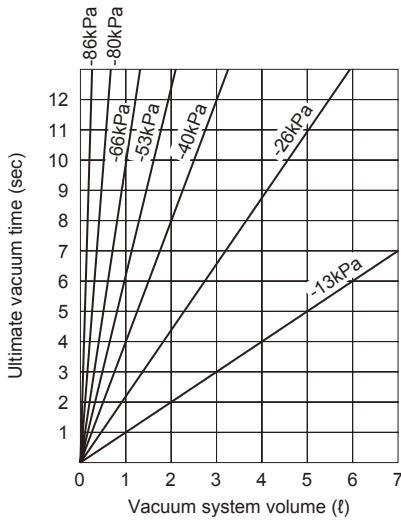

● VSH-L05, VSB-L05

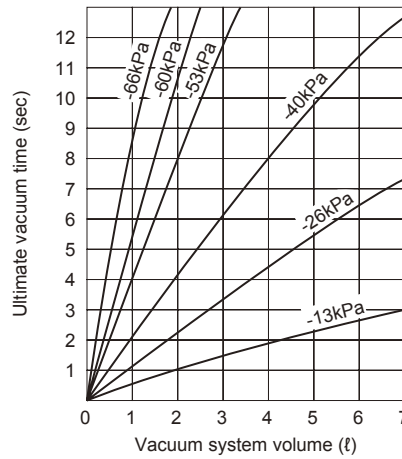

● VSU-H05

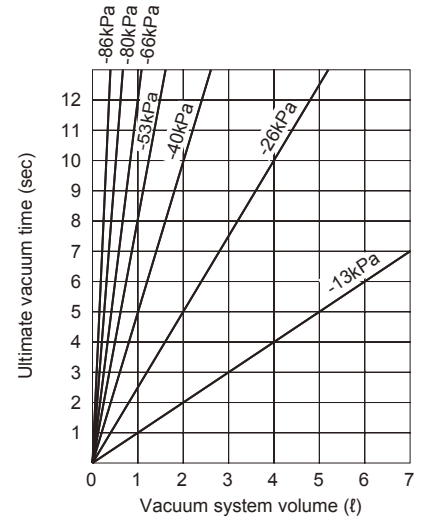

● VSU-L05

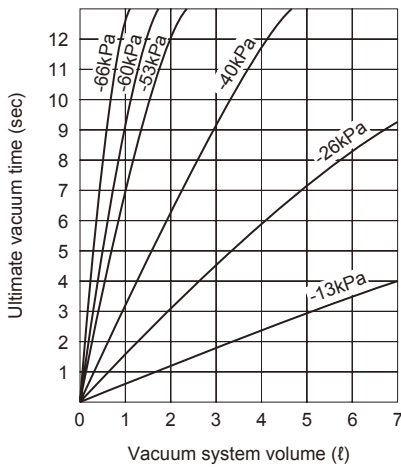

● VSU-H07

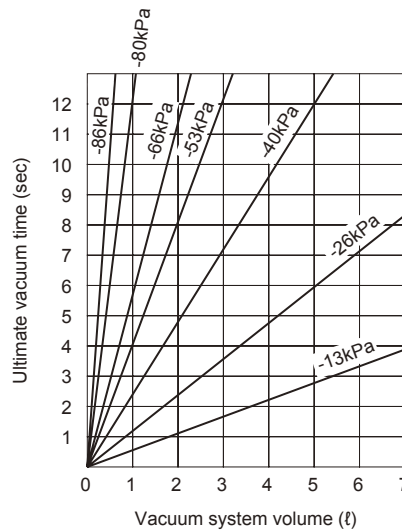

● VSU-L07

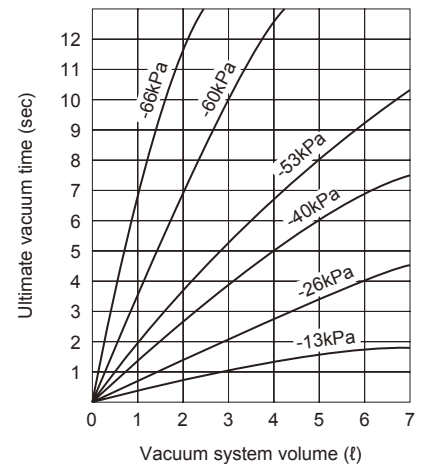

● VSU-E07

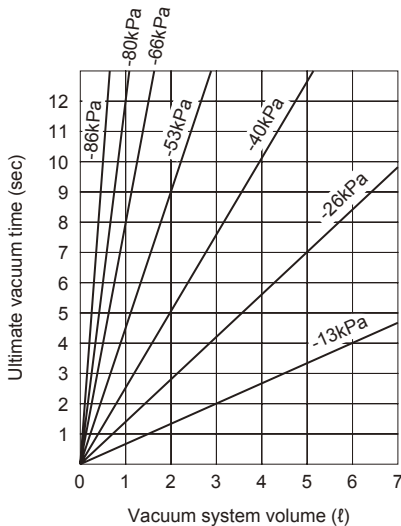

● VSH-H07, VSB-H07

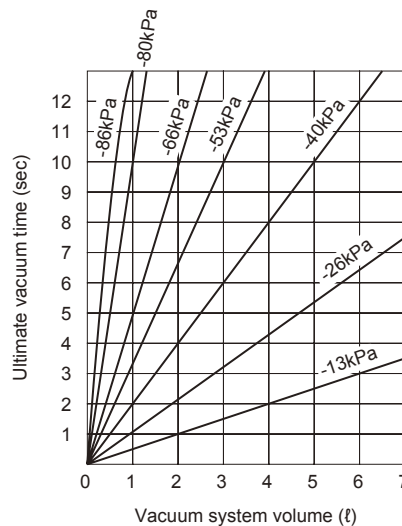

● VSH-L07, VSB-L07

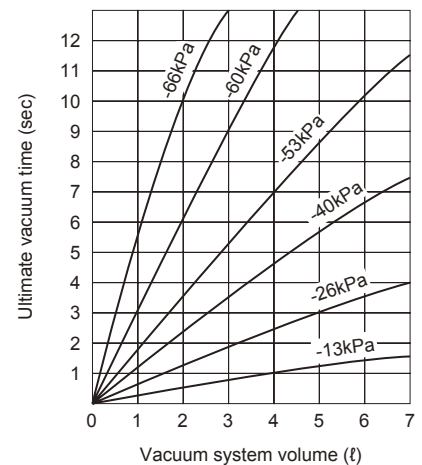

Ejector system

VSJ

VSH-VSU
VSB-VSC

VSG

VSK
VSKM

VSJ
VSJM

VSX
VSXM

VSQ

VSZM

VSH/VSU/VSB/VSC Series

Vacuum characteristics

(References) Ultimate vacuum time (supply pressure H type: 0.5MPa, L type: 0.5MPa, E type: 0.3 to 0.5MPa)

* Values differ with vacuum system piping shape, etc., so use these valves for reference.

● VSH-E07, VSB-E07

● VSH-H10, VSB-H10

● VSH-L10, VSB-L10

Ejector system

VSU

VSH-VSU
VSB-VSC

VSG

VSK
VSKM

VSJ
VSJM

VSX
VSXM

VSQ

VSZM

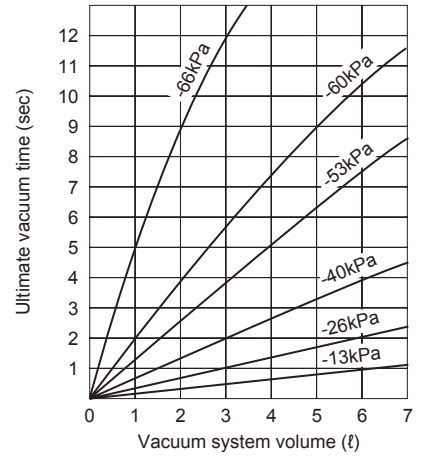
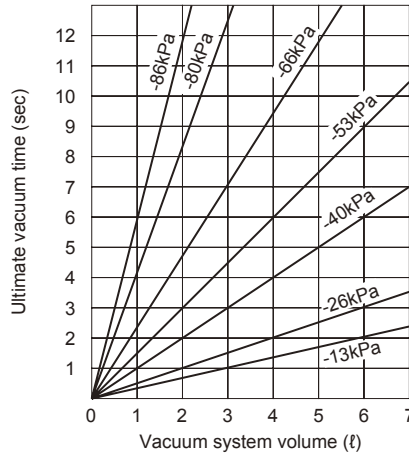
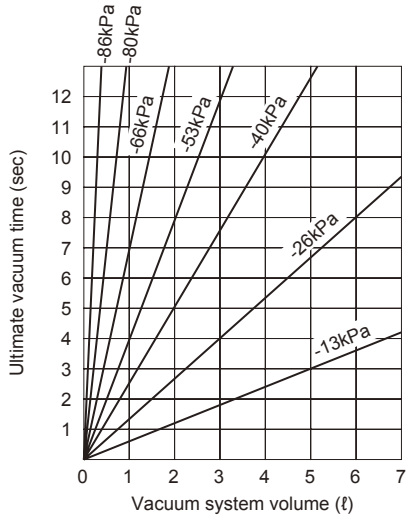

● VSH-E10

● VSH-H12, VSB-H12

● VSH-E12, VSB-E12

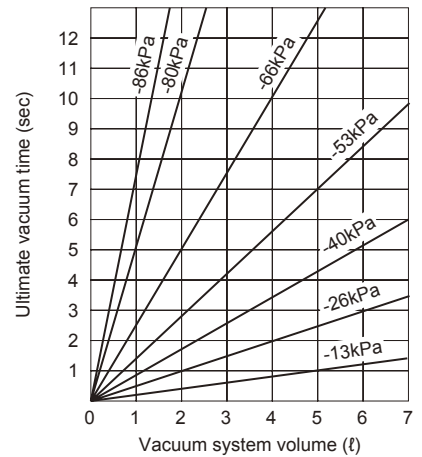
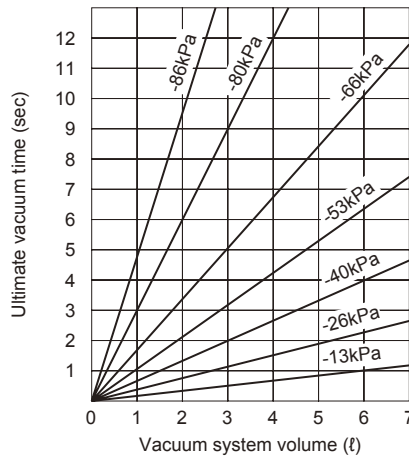
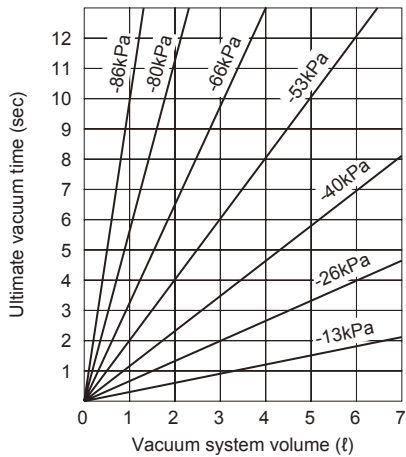

● VSH-H15

● VSH-L15

● VSH-E15

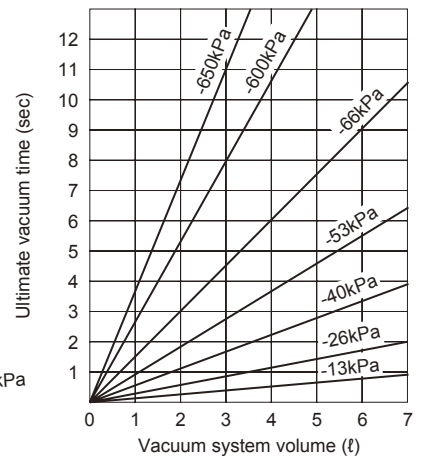
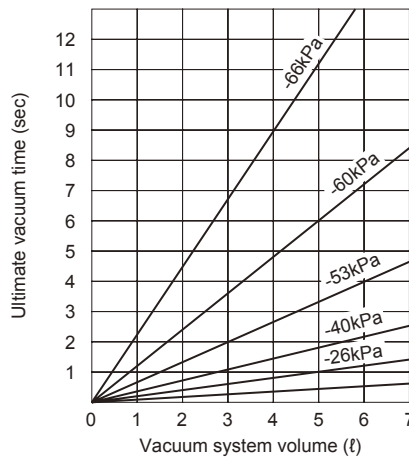
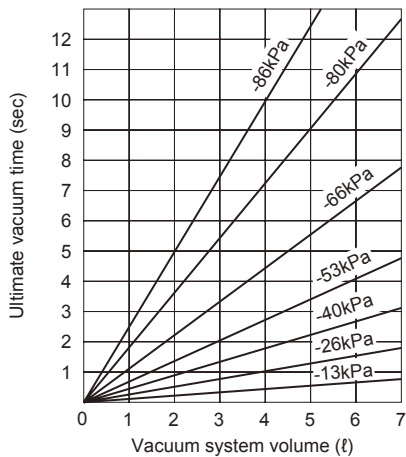

VSH/VSU/VSB/VSC Series

Vacuum characteristics / internal structure and parts list

Vacuum characteristics

(References) Ultimate vacuum time (supply pressure H type: 0.5MPa, L type: 0.5MPa, E type: 0.3 to 0.5MPa)

* Values differ with vacuum system piping shape, etc., so use these valves for reference.

● VSH-H20, VSC-H20

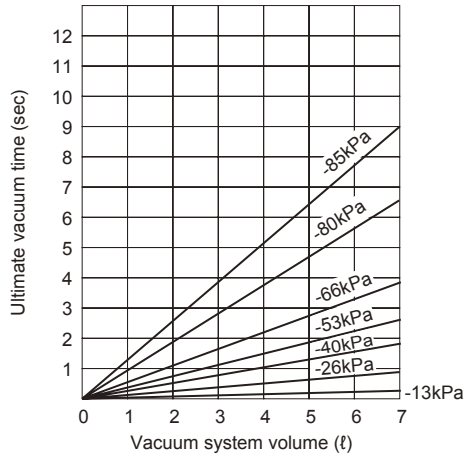

● VSH-E20, VSC-E20

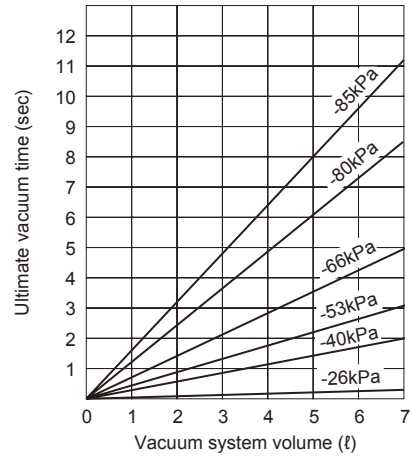

Internal structure and parts list

● VSH Series

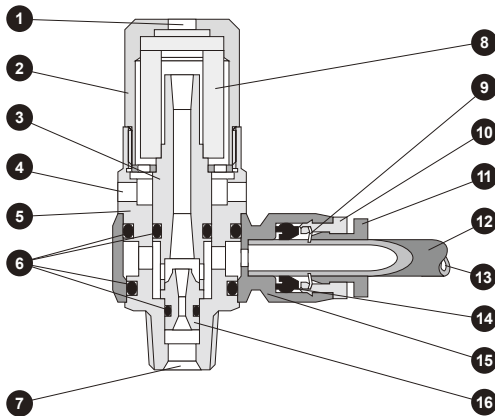

No.	Parts name	Material	Remarks
1	Exhaust port (EX)		
2	Cap	Aluminum	
3	Diffuser	Brass	Electroless nickel plating
4	Exhaust port (EX)		
5	Metal	Brass	Electroless nickel plating
6	O ring	Nitrile rubber	
7	Air supply port (P)		
8	Silencer element	Poly-vinyl formal	
9	Lock jaw	Stainless steel	
10	Guide ring	Brass	Electroless nickel plating
11	Release ring	Polyacetal	
12	Tube		
13	Vacuum port (V)		
14	Rubber sleeve	Nitrile rubber	
15	Resin	PBT	
16	Nozzle	Brass	Electroless nickel plating

Ejector system

VSY

VSH-VSU
VSB-VSC

VSG

VSK
VSKM

VSJ
VSJM

VSX
VSXM

VSQ

VSZM

Dimensions

● VSH-*-*S (atmospheric release with silencer)

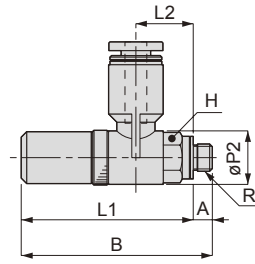
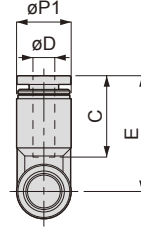
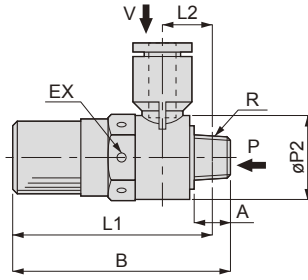
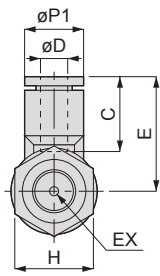

Meter screw type

Unit: mm

Model no.	O.D. ϕD	R	A	B	L1	L2	$\phi P1$	$\phi P2$	C	E	Opposite side H	Nozzle diameter (mm)	Working pressure (MPa)	Ultimate vacuum (-kPa)	Suction flow ($l/min.$ (ANR))	Air consumption ($l/min.$ (ANR))	Weight (g)					
VSH-H 05-4M5S	4	M5 x 0.8	3	34.5	31.5	10.5	10	9.8	14.9	21.2	8	0.5	0.5	90	7	11.5	13					
VSH-H 05-66AS	6	R1/8	8	48	44	11.4	12.4	18.4	17	25.5	17	0.7		17	93	13	23	37				
VSH-H 07-66AS												1				28	46	36.5				
VSH-H 10-66AS												1.2				38	70	36.5				
VSH-H 12-66AS												1				28	46	38				
VSH-H 10-86AS	8	R1/8	11	71.5	65.5	12.4	14.4	22	18.1	28.4	22	1.5		93	104	200	116	38				
VSH-H 12-86AS																		1.2	38	70	37.5	
VSH-H 15-88AS	10	R1/4	11	99.6	93.5	13.5	17.6	28	20.2	31.2	24	2.0		93	104	200	116	77				
VSH-H 15-108AS																		14.8	63	100	79.5	
VSH-H 20-108AS																		15.1	104	200	116	
VSH-H 20-128AS																		16.8	104	200	116	
VSH-L 05-4M5S	4	M5 x 0.8	3	34.5	31.5	10.5	10	9.8	14.9	21.2	8	0.5		0.5	66	12	11.5	13				
VSH-L 05-66AS	6	R1/8	8	48	44	11.4	12.4	18.4	17	25.5	17	0.7	17			66	26	23	37			
VSH-L 07-66AS												1					42	46	36			
VSH-L 10-66AS												0.7					26	23	38.5			
VSH-L 12-66AS												1					42	46	37.5			
VSH-L 10-86AS	8	R1/8	11	71.5	65.5	12.4	14.4	22	18.1	28.4	22	1.5	66			174	200	116	75			
VSH-L 07-86AS																			1	42	46	37.5
VSH-L 15-88AS	10	R1/4	11	99.6	93.5	13.5	17.6	28	20.2	31.2	24	2.0	66			174	200	116	77.5			
VSH-L 15-108AS																			14.8	95	100	77.5
VSH-L 15-128AS																			16.5	174	200	116
VSH-L 20-108AS																			15.1	174	200	116
VSH-L 20-128AS	16.8	174	200	116																		
VSH-E 07-66AS	6	R1/8	8	48	44	11.4	12.4	18.4	17	25.5	17	0.7	17	92	10.5	17	36.5					
VSH-E 10-66AS												1			21	34	37					
VSH-E 12-66AS												1.2			27	47	36.5					
VSH-E 10-86AS												1			21	34	38.5					
VSH-E 12-86AS	8	R1/8	11	71.5	65.5	12.4	14.4	22	18.1	28.4	22	1.5	92	82	150	116	38					
VSH-E 10-86AS																	1.2	27	47	38		
VSH-E 15-88AS	10	R1/4	11	99.6	93.5	13.5	17.6	28	20.2	31.2	24	2.0	92	82	150	116	78					
VSH-E 15-108AS																	14.8	42	70	80		
VSH-E 20-108AS																	15.1	82	150	116		
VSH-E 20-128AS																	16.8	82	150	116		

Note: L1 and L2 dimensions for tapered screws are reference dimensions applicable after screw tightening.

Dimensions

● VSH-**-*J (common exhaust)

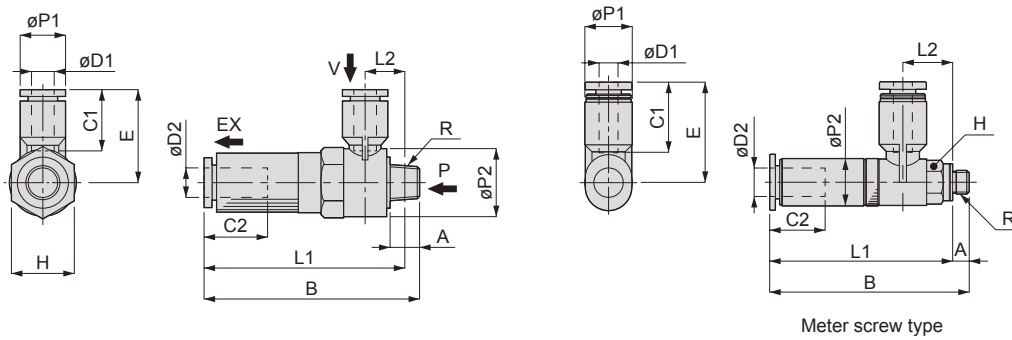

Unit: mm

Model no.	O.D. $\phi D1$	O.D. $\phi D2$	R	A	B	L1	L2	$\phi P1$	$\phi P2$	C1	C2	E	Opposite side H	Nozzle diameter (mm)	Working pressure (MPa)	Ultimate vacuum (-kPa)	Suction flow (l/min, (ANR))	Air consumption (l/min, (ANR))	Weight (g)				
VSH-H 05-4M5J	4	6	M5 x 0.8	3	41.8	38.8	10.5	10	10	14.9	11.9	21.2	8	0.5		90	7	11.5	18				
VSH-H 05-66AJ	6	8	R1/8	8	58.4	54.4	11.4	12.4	18.4	17	18.2	25.5	17	0.7	0.5	93	13	23	45.5				
VSH-H 07-66AJ							1							28			46	44.5					
VSH-H 10-66AJ							1.2							38			70	44					
VSH-H 12-66AJ							1							28			46	45.5					
VSH-H 10-86AJ	8						12.4	14.4		18.1		28.4		0.5	93	38	70	46					
VSH-H 12-86AJ							1.2									38	70	46					
VSH-H 15-88AJ	10	12	R1/4	11	76.9	70.9	13.5	17.6	22	20.2	23.3	28.9	22	1.5		66	63	100	92				
VSH-H 15-108AJ							14.8										31.2	95	100	94.5			
VSH-H 20-108AJ							15.1										33.6	104	200	128			
VSH-H 20-128AJ	12				89.4	83.3	16.8	21	28	23.4		36.4	24	2.0		104	200	128					
VSH-L 05-4M5J	4	6	M5 x 0.8	3	41.8	38.8	10.5	10	10	14.9	11.9	21.2	8	0.5		66	12	11.5	18				
VSH-L 05-66AJ	6	8	R1/8	8	58.4	54.4	11.4	12.4	18.4	17	18.2	25.5	17	0.7	0.5	66	26	23	45				
VSH-L 07-66AJ							1							42			46	44					
VSH-L 10-66AJ							0.7							26			23	46					
VSH-L 07-86AJ							1							42			46	45					
VSH-L 10-86AJ	8						12.4	14.4		18.1		28.4		0.5	66	42	46	45					
VSH-L 15-88AJ							13.5									28.9	89.5						
VSH-L 15-108AJ	10	12	R1/4	11	76.9	70.9	14.8	17.6	22	20.2	23.3	31.2	22	1.5		66	95	100	93				
VSH-L 15-128AJ							16.5										21	23.4	23.3	36.9	174	200	128
VSH-L 20-108AJ							15.1										17.6	20.2	23.3	33.6	174	200	128
VSH-L 20-128AJ	12				89.4	83.3	16.8	21	28	23.4		36.4	24	2.0		174	200	128					
VSH-E 07-66AJ	6	8	R1/8	8	58.4	54.4	11.4	12.4	18.4	17	18.2	25.5	17	0.7	0.35	92	10.5	17	45				
VSH-E 10-66AJ							1							21			34	44.5					
VSH-E 12-66AJ							1.2							27			47	46.5					
VSH-E 10-86AJ							1							21			34	46.5					
VSH-E 12-86AJ	8						12.4	14.4		18.1		28.4		0.35	92	27	47	45.5					
VSH-E 15-88AJ							13.5									28.9	42	70	92				
VSH-E 15-108AJ	10	12	R1/4	11	76.9	70.9	14.8	17.6	22	20.2	23.3	31.2	22	1.5		92	42	70	95.5				
VSH-E 15-128AJ							15.1										17.6	20.2	23.3	33.6	82	150	128
VSH-E 20-108AJ							15.1										17.6	20.2	23.3	33.6	82	150	128
VSH-E 20-128AJ	12				89.4	83.3	16.8	21	28	23.4		36.4	24	2.0		82	150	128					

Note: L1 and L2 dimensions for tapered screws are reference dimensions applicable after screw tightening.

Model no.

● Silencer kit

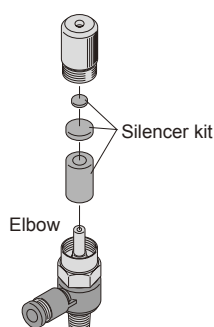

Silencer kit model no.	Vacuum ejector model no.
VSH-M5-SK	VSH-**-*M5S
VSH-6A-SK	VSH-**-*6AS
VSH-8A-SK	VSH-**-*8AS

Note: For VSH-*20-***, VSC-20-SK (silencer kit for VSC-20) is used.

Dimensions

● VSU-*-*S (atmospheric release with silencer)

Unit: mm

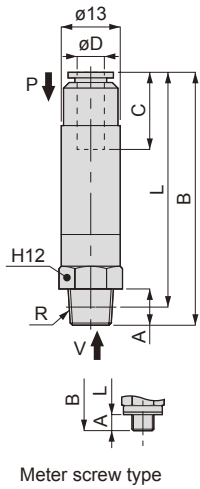

Model no.	O.D. øD	R	A	B	L	C	Nozzle diameter (mm)	Ultimate vacuum (-kPa)	Suction flow (l/min. (ANR))	Air consumption (l/min. (ANR))	Weight (g)																
VSU-H 05-M54S	4	M5 x 0.8	3	50.3	47.3	10.9	0.5	90	7	11.5	17.5																
VSU-H 05-M56S	6			51.3	48.3	11.7					17																
VSU-H 05-6A4S	4	R1/8	8	54.3	50.3	10.9					0.7	92	12.5	23	20												
VSU-H 05-6A6S	6			55.3	51.3	11.7									19.5												
VSU-H 07-M54S	4	M5 x 0.8	3	57.1	54.1	10.9									0.7	92	12.5	23	19								
VSU-H 07-M56S	6			57.8	54.8	11.7													18								
VSU-H 07-6A4S	4	R1/8	8	61.1	57.1	10.9	0.7	92	12.5	23									21								
VSU-H 07-6A6S	6			61.8	57.8	11.7													20.5								
VSU-L 05-M54S	4	M5 x 0.8	3	50.3	47.3	10.9													0.5	66	12	11.5	17.5				
VSU-L 05-M56S	6			51.3	48.3	11.7																	17				
VSU-L 05-6A4S	4	R1/8	8	54.3	50.3	10.9									0.7	66	20	23					20				
VSU-L 05-6A6S	6			55.3	51.3	11.7																	19.5				
VSU-L 07-M54S	4	M5 x 0.8	3	57.1	54.1	10.9																	0.7	66	20	23	19
VSU-L 07-M56S	6			57.8	54.8	11.7																					18
VSU-L 07-6A4S	4	R1/8	8	61.1	57.1	10.9					0.7	90	10	17					21								
VSU-L 07-6A6S	6			61.8	57.8	11.7													20.5								
VSU-E 07-M54S	4	M5 x 0.8	3	57.1	54.1	10.9													0.7	90	10	17					19
VSU-E 07-M56S	6			57.8	54.8	11.7																					21.5
VSU-E 07-6A4S	4	R1/8	8	61.1	57.1	10.9	0.7	90	10	17													20.5				
VSU-E 07-6A6S	6			61.8	57.8	11.7																	20.5				

Note 1: L dimensions for tapered screws are reference dimensions applicable after screw tightening.
 Note 2: M5 screw's opposite hexagon side is knurled. H12 applies to 6A (R1/8) screw.

● VSU-*-*J (common exhaust)

Unit: mm

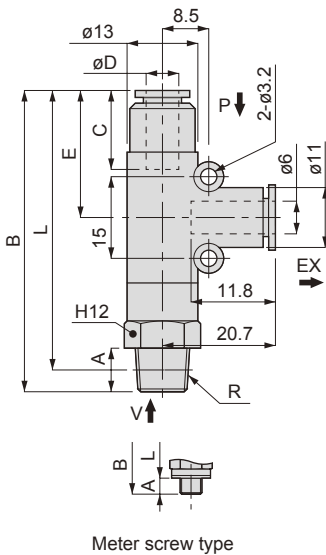

Model no.	O.D. øD	R	A	B	L	C	E	Nozzle diameter (mm)	Ultimate vacuum (-kPa)	Suction flow (l/min. (ANR))	Air consumption (l/min. (ANR))	Weight (g)																
VSU-H 05-M54J	4	M5 x 0.8	3	50.3	47.3	11.2	22.3	0.5	90	7	11.5	20																
VSU-H 05-M56J	6			51.3	48.3	11.9	23.3					19.5																
VSU-H 05-6A4J	4	R1/8	8	54.3	50.3	11.2	22.3					0.7	92	12.5	23	22.5												
VSU-H 05-6A6J	6			55.3	51.3	11.9	23.3									22												
VSU-H 07-M54J	4	M5 x 0.8	3	57.1	54.1	11.2	29.1									0.7	92	12.5	23	21								
VSU-H 07-M56J	6			57.8	54.8	11.9	29.8													20.5								
VSU-H 07-6A4J	4	R1/8	8	61.1	57.1	11.2	29.1	0.7	92	12.5	23									23.5								
VSU-H 07-6A6J	6			61.8	57.8	11.9	29.8													23								
VSU-L 05-M54J	4	M5 x 0.8	3	50.3	47.3	11.2	22.3													0.5	66	12	11.5	19.5				
VSU-L 05-M56J	6			51.3	48.3	11.9	23.3																	22				
VSU-L 05-6A4J	4	R1/8	8	54.3	50.3	11.2	22.3									0.7	66	20	23					21.5				
VSU-L 05-6A6J	6			55.3	51.3	11.9	23.3																	22.5				
VSU-L 07-M54J	4	M5 x 0.8	3	57.1	54.1	11.2	29.1																	0.7	66	20	23	20
VSU-L 07-M56J	6			57.8	54.8	11.9	29.8																					20
VSU-L 07-6A4J	4	R1/8	8	61.1	57.1	11.2	29.1					0.7	90	10	17					23								
VSU-L 07-6A6J	6			61.8	57.8	11.9	29.8													22.5								
VSU-E 07-M54J	4	M5 x 0.8	3	57.1	54.1	11.2	29.1													0.7	90	10	17					21.5
VSU-E 07-M56J	6			57.8	54.8	11.9	29.8																					20.5
VSU-E 07-6A4J	4	R1/8	8	61.1	57.1	11.2	29.1	0.7	90	10	17													23.5				
VSU-E 07-6A6J	6			61.8	57.8	11.9	29.8																	23				

Note 1: L dimensions for tapered screws are reference dimensions applicable after screw tightening.
 Note 2: M5 screw's opposite hexagon side is knurled. H12 applies to 6A (R1/8) screw.

Dimensions

● VSU-*-*S (atmospheric release with elbow union, silencer)

Unit: mm

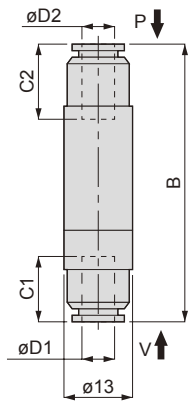

Model no.	O.D. ØD1	O.D. ØD2	B	C1	C2	Nozzle diameter (mm)	Ultimate vacuum (-kPa)	Suction flow (l/min. (ANR))	Air consumption (l/min. (ANR))	Weight (g)														
VSU-H 05-44S	4	4	49.9	11.2	11.2	0.5	90	7	11.5	18.5														
VSU-H 05-46S		6	50.9		11.9																			
VSU-H 05-64S	6	4	50.6	11.9	11.2					66	12	11.5	18											
VSU-H 05-66S		6	51.6		11.9								17.5											
VSU-H 07-44S	4	4	56.7	11.2	11.2								0.7	92	12.5	23	20							
VSU-H 07-46S		6	57.4		11.9												19.5							
VSU-H 07-64S	6	4	57.4	11.9	11.2	90	10	17	19															
VSU-H 07-66S		6	58.1		11.9				18.5															
VSU-L 05-44S	4	4	49.9	11.2	11.2				0.5								66	12	11.5	18.5				
VSU-L 05-46S		6	50.9		11.9																17.5			
VSU-L 05-64S	6	4	50.6	11.9	11.2								0.7	90	10	17				20				
VSU-L 05-66S		6	51.6		11.9															19.5				
VSU-L 07-44S	4	4	56.7	11.2	11.2															0.7	92	12.5	23	20
VSU-L 07-46S		6	57.4		11.9																			19.5
VSU-L 07-64S	6	4	57.4	11.9	11.2				90	10	17	18.5												
VSU-L 07-66S		6	58.1		11.9							17.5												
VSU-E 07-44S	4	4	56.7	11.2	11.2							0.7					90	10	17					20.5
VSU-E 07-46S		6	57.4		11.9																			19.5
VSU-E 07-64S	6	4	57.4	11.9	11.2	90	10	17												18.5				
VSU-E 07-66S		6	58.1		11.9															19				

Ejector system

VSU

VSH-VSU
VSB-VSC

VSG

● VSU-*-*J (elbow union, common exhaust)

Unit: mm

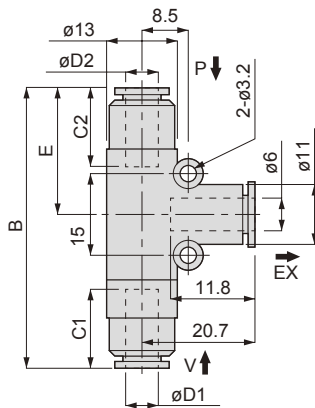

Model no.	O.D. ØD1	O.D. ØD2	B	C1	C2	E	Nozzle diameter (mm)	Ultimate vacuum (-kPa)	Suction flow (l/min. (ANR))	Air consumption (l/min. (ANR))	Weight (g)															
VSU-H 05-44J	4	4	49.9	11.2	11.2	22.3	0.5	90	7	11.5	21															
VSU-H 05-46J		6	50.9		23.3	20.5																				
VSU-H 05-64J	6	4	50.6	11.9	11.2	22.3					0.7	92	12.5	23	20											
VSU-H 05-66J		6	51.6		23.3	19.5																				
VSU-H 07-44J	4	4	56.7	11.2	11.2	29.1									0.7	92	12.5	23	22.5							
VSU-H 07-46J		6	57.4		29.8	21.5																				
VSU-H 07-64J	6	4	57.4	11.9	11.2	29.1	90	10	17	21.5																
VSU-H 07-66J		6	58.1		29.8	20.5																				
VSU-L 05-44J	4	4	49.9	11.2	11.2	22.3				0.5									66	12	11.5	21				
VSU-L 05-46J		6	50.9		23.3	20.5																				
VSU-L 05-64J	6	4	50.6	11.9	11.2	22.3									0.7	92	12.5	23				20				
VSU-L 05-66J		6	51.6		23.3	19.5																				
VSU-L 07-44J	4	4	56.7	11.2	11.2	29.1																0.7	92	12.5	23	22
VSU-L 07-46J		6	57.4		29.8	22																				
VSU-L 07-64J	6	4	57.4	11.9	11.2	29.1				90	10	17	21.5													
VSU-L 07-66J		6	58.1		29.8	20.5																				
VSU-E 07-44J	4	4	56.7	11.2	11.2	29.1							0.7	90					10	17	22					
VSU-E 07-46J		6	57.4		29.8	21.5																				
VSU-E 07-64J	6	4	57.4	11.9	11.2	29.1	90	10	17												21.5					
VSU-E 07-66J		6	58.1		29.8	20.5																				

VSK
VSKM

VSJ
VSJM

VSX
VSXM

VSQ

VSZM

Dimensions

● VSU fixing bracket

Unit: mm

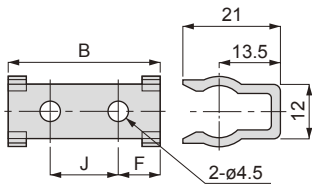

Model no.	B	F	J	Weight (g)
VSU-05-B	33.2	9	15	2
VSU-07-B	39.2	10	20	2

Note: VSU-05-B is for 0.5mm nozzle diameters and VSU-07-B is for 0.7mm nozzle diameters.

Model no.

● Filter element

VSU-E

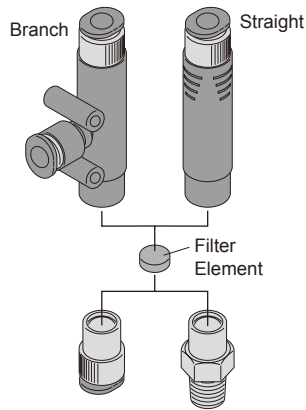

Ejector system

VSU

VSH-VSU
VSB-VSC

VSG

VSK
VSKM

VSJ
VSJM

VSX
VSXM

VSQ

VSZM

Dimensions

● VSB-*-* (atmospheric release)

Unit: mm

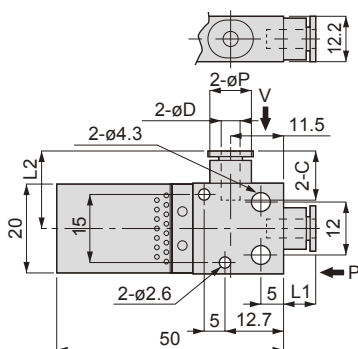

Model no.	O.D. ϕD	ϕP	C	L1	L2	Nozzle diameter (mm)	Working pressure (MPa)	Ultimate vacuum (-kPa)	Suction flow (l/min. (ANR))	Air consumption (l/min. (ANR))	Weight (g)
VSB-H 05-44	4	9	11.3	6.9	16.9	0.5	0.5	90	7	11.5	18
VSB-H 07-66	6	10.6	11.8	7.2	17.2	0.7	0.5	93	13	23	18.5
VSB-H 10-66						1			28	46	
VSB-H 12-66						1.2			38	70	
VSB-L 05-44	4	9	11.3	6.9	16.9	0.5	0.45	66	12	11.5	18
VSB-L 07-66	6	10.6	11.8	7.2	17.2	0.7			26	23	18.5
VSB-L 10-66						1			42	46	17.5
VSB-E 07-66	6	10.6	11.8	7.2	17.2	0.7	0.4	92	10.5	17	18.5
VSB-E 10-66						1			21	34	
VSB-E 12-66						1.2			27	47	

● VSB-*-*V (with vacuum switch)

Unit: mm

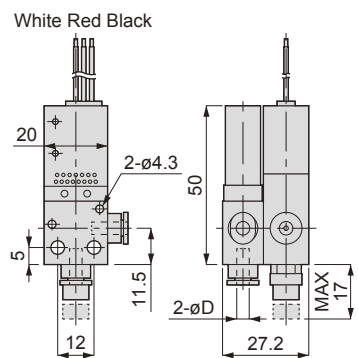

Model no.	O.D. ϕD	Nozzle diameter (mm)	Working pressure (MPa)	Ultimate vacuum (-kPa)	Suction flow (l/min. (ANR))	Air consumption (l/min. (ANR))	Weight (g)
VSB-H 05-44V	4	0.5	0.5	90	7	11.5	46.5
VSB-H 07-66V	6	0.7	0.5	93	13	23	46
VSB-H 10-66V		1			28	46	47
VSB-H 12-66V		1.2			38	70	47.5
VSB-L 05-44V	4	0.5	0.45	66	12	11.5	46.5
VSB-L 07-66V	6	0.7			26	23	48
VSB-L 10-66V		1			42	46	46.5
VSB-E 07-66V	6	0.7	0.4	92	10.5	17	48.5
VSB-E 10-66V		1			21	34	
VSB-E 12-66V		1.2			27	47	

Note: Lead wire White: COMMON
Red: N.C.
Black: N.O.

● VSB-VUSM-* Discrete mechanical vacuum switch

Unit: mm

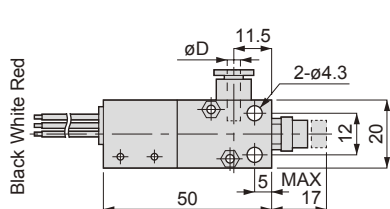

Model no.	Tube outer diameter		Weight (g)
	ϕD		
VSB-VUSM-4	4		29
VSB-VUSM-6	6		29

Note: Lead wire White: COMMON
Red: N.C.
Black: N.O.

Model no.

● Silencer element

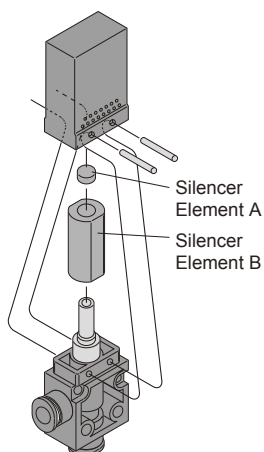

Element A model no.	Element B model no.
VSB-EA	VSB-EB

Note: VSB / VSG / VSJ common part

Note: VSB and VSG common part

Dimensions

- VSC-*-*S (straight type, atmospheric release with silencer)

Unit: mm

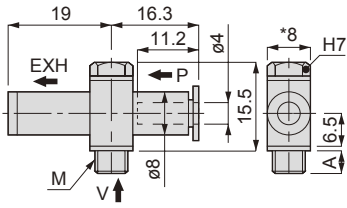

Model no.	M	A	Nozzle diameter (mm)	Ultimate vacuum (-kPa)	Suction flow (l/min. (ANR))	Air consumption (l/min. (ANR))	Weight (g)
VSC-H 05-M54S	M5 x 0.8	3	0.5	90	7	11.5	14.5
VSC-L 05-M54S	M5 x 0.8	3	0.5	66	11	11.5	17

Ejector system

VSJ

VSH·VSU
VSB·VSC

VSG

VSK
VSKM

VSJ
VSJM

VSX
VSXM

VSQ

VSZM

Dimensions

● VSC-*-*S (atmospheric release with silencer)

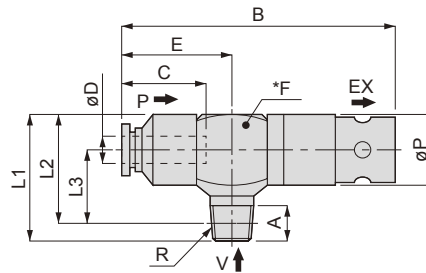

Unit: mm

Model no.	O.D. øD	R	A	L1	L2	L3	øP	B	E	C	*F	Nozzle diameter (mm)	Ultimate vacuum (-kPa)	Suction flow (l/min. (ANR))	Air consumption (l/min. (ANR))	Weight (g)			
VSC-H 07-6A6S	6	R1/8	8	28	24	16	16	62.5	24.5	17	16	0.7	93	13	23	31.5			
VSC-H 07-6A8S	8							65.2	27.2	18.2		1							
VSC-H 10-6A6S	6							62.5	24.5	17		1.2							
VSC-H 10-6A8S	8							65.2	27.2	18.2									
VSC-H 12-6A6S	6							62.5	24.5	17									
VSC-H 12-6A8S	8							65.2	27.2	18.2									
VSC-H 15-8A8S	8	R1/4	11	39	33	21	24	104.2	29.2	18.2	22	1.5	63	100	87				
VSC-H 15-10A8S	8	R3/8	12		32.7	20.7		104.2	29.2	18.2					88				
VSC-H 15-8A10S	10	R1/4	11		33	21		105.9	30.9	20.7					89				
VSC-H 15-10A10S		R3/8	12		32.7	20.7		105.9	30.9	20.7		91							
VSC-H 20-8A8S	8	R1/4	11		33	21		104.2	29.2	18.2		2			93	110	200	92	
VSC-H 20-10A8S	8	R3/8	12		32.7	20.7		104.2	29.2	18.2								92.5	
VSC-H 20-8A10S	10	R1/4	11	33	21	105.9	30.9	20.7	93.5										
VSC-H 20-10A10S		R3/8	12	32.7	20.7	105.9	30.9	20.7	93.5										
VSC-L 07-6A6S	6	R1/8	8	28	24	16	16	62.5	24.5	17	16	0.7	66	26	23	31.5			
VSC-L 07-6A8S	8							65.2	27.2	18.2		1							
VSC-L 10-6A6S	6							62.5	24.5	17							1.5		
VSC-L 10-6A8S	8							65.2	27.2	18.2		95						100	85
VSC-L 15-8A8S	8	R1/4	11	39	33	21	24	104.2	29.2	18.2	22	1.5	95	100	86				
VSC-L 15-10A8S	8	R3/8	12		32.7	20.7		104.2	29.2	18.2					86.5				
VSC-L 15-8A10S	10	R1/4	11		33	21		105.9	30.9	20.7					87.5				
VSC-L 15-10A10S		R3/8	12		32.7	20.7		105.9	30.9	20.7		87							
VSC-L 20-8A8S	8	R1/4	11		33	21		104.2	29.2	18.2		2			180	200	88		
VSC-L 20-10A8S	8	R3/8	12		32.7	20.7		104.2	29.2	18.2							89		
VSC-L 20-8A10S	10	R1/4	11	33	21	105.9	30.9	20.7	89										
VSC-L 20-10A10S		R3/8	12	32.7	20.7	105.9	30.9	20.7	89										
VSC-E 07-6A6S	6	R1/8	8	28	24	16	16	62.5	24.5	17	16	0.7	92	10.5	17	31.5			
VSC-E 07-6A8S	8							65.2	27.2	18.2		1							
VSC-E 10-6A6S	6							62.5	24.5	17							1.2		
VSC-E 10-6A8S	8							65.2	27.2	18.2		21						34	87.5
VSC-E 12-6A6S	6							62.5	24.5	17		1.5					42	70	88.5
VSC-E 12-6A8S	8							65.2	27.2	18.2									27
VSC-E 15-8A8S	8	R1/4	11	39	33	21	24	104.2	29.2	18.2	22		1.5	84	150	92.5			
VSC-E 15-10A8S	8	R3/8	12		32.7	20.7		104.2	29.2	18.2		93.5							
VSC-E 15-8A10S	10	R1/4	11		33	21		105.9	30.9	20.7		94							
VSC-E 15-10A10S		R3/8	12		32.7	20.7		105.9	30.9	20.7		95							
VSC-E 20-8A8S	8	R1/4	11		33	21		104.2	29.2	18.2		2	84			150	92.5		
VSC-E 20-10A8S	8	R3/8	12		32.7	20.7		104.2	29.2	18.2							93.5		
VSC-E 20-8A10S	10	R1/4	11	33	21	105.9	30.9	20.7	94										
VSC-E 20-10A10S		R3/8	12	32.7	20.7	105.9	30.9	20.7	95										

Note: L1, L2 and L3 dimensions are references applicable after screw tightening.

Ejector system

VSY

VSH-VSU
VSB-VSC

VSG

VSK
VSKM

VSJ
VSJM

VSX
VSXM

VSQ

VSZM

Dimensions

● VSC-*-*J (common exhaust)

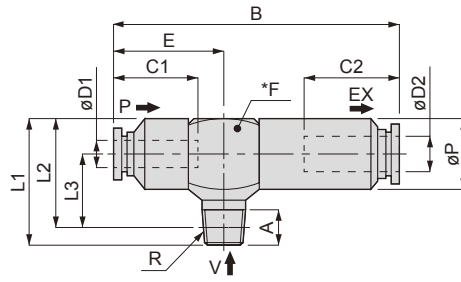

Unit: mm

Model no.	O.D. øD1	O.D. øD2	R	A	L1	L2	L3	øP	B	E	C1	C2	*F	Nozzle diameter (mm)	Ultimate vacuum (-kPa)	Suction flow (l/min. (ANR))	Air consumption (l/min. (ANR))	Weight (g)
VSC-H 07-6A6J	6	8	R1/8	8	28	24	16	16	64.7	24.5	17	18.2	16	0.7	93	13	23	36.5
VSC-H 07-6A8J	8								67.4	27.2	18.2							
VSC-H 10-6A6J	6	8	R1/8	8	28	24	16	16	64.7	24.5	17	18.2	16	1	93	28	46	36.5
VSC-H 10-6A8J	8								67.4	27.2	18.2							
VSC-H 12-6A6J	6	8	R1/8	8	28	24	16	16	64.7	24.5	17	18.2	16	1.2	93	38	70	36.5
VSC-H 12-6A8J	8								67.4	27.2	18.2							
VSC-H 15-8A8J	8	12	R1/4	11	38	32	21	22	94	29.2	18.2	23.3	22	1.5	93	63	100	98.5
VSC-H 15-10A8J	8		R3/8	12		31.7	20.7		99.5									
VSC-H 15-8A10J	10	12	R1/4	11	38	32	21	22	95.7	30.9	20.7	23.3	22	1.5	93	110	200	100.5
VSC-H 15-10A10J	10		R3/8	12		31.7	20.7		103									
VSC-H 20-8A8J	8	12	R1/4	11	38	32	21	22	94	29.2	18.2	23.3	22	2	93	110	200	104
VSC-H 20-10A8J	8		R3/8	12		31.7	20.7		105									
VSC-H 20-8A10J	10	12	R1/4	11	38	32	21	22	95.7	30.9	20.7	23.3	22	2	93	110	200	105
VSC-H 20-10A10J	10		R3/8	12		31.7	20.7		105									
VSC-L 07-6A6J	6	8	R1/8	8	28	24	16	16	64.7	24.5	17	18.2	16	0.7	66	26	23	36.5
VSC-L 07-6A8J	8								67.4	27.2	18.2							
VSC-L 10-6A6J	6	8	R1/8	8	28	24	16	16	64.7	24.5	17	18.2	16	1	66	42	46	36.5
VSC-L 10-6A8J	8								67.4	27.2	18.2							
VSC-L 15-8A8J	8	12	R1/4	11	38	32	21	22	94	29.2	18.2	23.3	22	1.5	66	95	100	97
VSC-L 15-10A8J	8		R3/8	12		31.7	20.7		98									
VSC-L 15-8A10J	10	12	R1/4	11	38	32	21	22	95.7	30.9	20.7	23.3	22	1.5	66	95	100	99
VSC-L 15-10A10J	10		R3/8	12		31.7	20.7		99									
VSC-L 20-8A8J	8	12	R1/4	11	38	32	21	22	94	29.2	18.2	23.3	22	2	66	180	200	98.5
VSC-L 20-10A8J	8		R3/8	12		31.7	20.7		99.5									
VSC-L 20-8A10J	10	12	R1/4	11	38	32	21	22	95.7	30.9	20.7	23.3	22	2	66	180	200	100
VSC-L 20-10A10J	10		R3/8	12		31.7	20.7		100.5									
VSC-E 07-6A6J	6	8	R1/8	8	28	24	16	16	64.7	24.5	17	18.2	16	0.7	92	10.5	17	36.5
VSC-E 07-6A8J	8								67.4	27.2	18.2							
VSC-E 10-6A6J	6	8	R1/8	8	28	24	16	16	64.7	24.5	17	18.2	16	1	92	21	34	36.5
VSC-E 10-6A8J	8								67.4	27.2	18.2							
VSC-E 12-6A6J	6	8	R1/8	8	28	24	16	16	64.7	24.5	17	18.2	16	1.2	92	27	47	36.5
VSC-E 12-6A8J	8								67.4	27.2	18.2							
VSC-E 15-8A8J	8	12	R1/4	11	38	32	21	22	94	29.2	18.2	23.3	22	1.5	92	42	70	99.5
VSC-E 15-10A8J	8		R3/8	12		31.7	20.7		100.5									
VSC-E 15-8A10J	10	12	R1/4	11	38	32	21	22	95.7	30.9	20.7	23.3	22	1.5	92	42	70	101.5
VSC-E 15-10A10J	10		R3/8	12		31.7	20.7		101.5									
VSC-E 20-8A8J	8	12	R1/4	11	38	32	21	22	94	29.2	18.2	23.3	22	2	92	84	150	104.5
VSC-E 20-10A8J	8		R3/8	12		31.7	20.7		105.5									
VSC-E 20-8A10J	10	12	R1/4	11	38	32	21	22	95.7	30.9	20.7	23.3	22	2	92	84	150	105.5
VSC-E 20-10A10J	10		R3/8	12		31.7	20.7		106.5									

Note: L1, L2 and L3 dimensions are references applicable after screw tightening.

Dimensions

● VSC-*-*S (air supply port elbow type, atmospheric release with silencer)

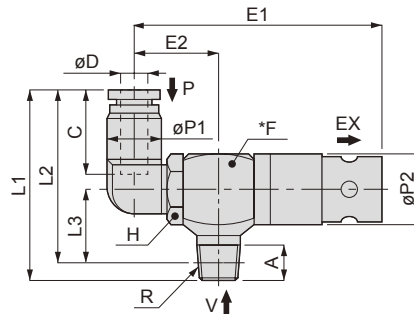

Unit: mm

Model no.	O.D. øD1	R	A	L1	L2	L3	E1	E2	øP1	øP2	C	Opposite side H	*F	Nozzle diameter (mm)	Ultimate vacuum (-kPa)	Suction flow (l/min. (ANR))	Air consumption (l/min. (ANR))	Weight (g)								
VSC-H 07-6A6LS	6	R1/8	8	42.8	38.8	16	57.3	19.3	12.5	16	17	14	16	0.7	93	13	23	31.5								
VSC-H 07-6A8LS	8			45.7	41.7		58.3	20.3	14.5		18.1							34								
VSC-H 10-6A6LS	6			42.8	38.8		57.3	19.3	12.5		17							31.5								
VSC-H 10-6A8LS	8			45.7	41.7		58.3	20.3	14.5		18.1			34												
VSC-H 12-6A6LS	6			42.8	38.8		57.3	19.3	12.5		17			31.5												
VSC-H 12-6A8LS	8			45.7	41.7		58.3	20.3	14.5		18.1			34												
VSC-H 15-8A8LS	8	R1/4	11	52.7	46.7	21	98.3	23.3	14.5	18.1	19	22	1.5	93	63	100	85.5									
VSC-H 15-10A8LS	8	R3/8	12	52.7	46.4	20.7	98.3	23.3	14.5	18.1							19	22	1.5	86.5						
VSC-H 15-8A10LS	10	R1/4	11	56.5	50.5	21	100.8	25.8	17.5	20.2	24	19	22				93	110	200	90.5						
VSC-H 15-10A10LS	10	R3/8	12	56.5	50.2	20.7	100.8	25.8	17.5	20.2										19	22	1.5	91.5			
VSC-H 20-8A8LS	8	R1/4	11	52.7	46.7	21	98.3	23.3	14.5	18.1	24	19	22							93	110	200	90			
VSC-H 20-10A8LS	8	R3/8	12	52.7	46.4	20.7	98.3	23.3	14.5	18.1													19	22	1.5	91
VSC-H 20-8A10LS	10	R1/4	11	56.5	50.5	21	100.8	25.8	17.5	20.2	24	19	22	93	110	200							95			
VSC-H 20-10A10LS	10	R3/8	12	56.5	50.2	20.7	100.8	25.8	17.5	20.2													19	22	1.5	96
VSC-L 07-6A6LS	6	R1/8	8	42.8	38.8	16	57.3	19.3	12.5	16	17	14	16				0.7	66	26				23	31.5		
VSC-L 07-6A8LS	8			45.7	41.7		58.3	20.3	14.5		18.1													34		
VSC-L 10-6A6LS	6			42.8	38.8		57.3	19.3	12.5		17									31.5						
VSC-L 10-6A8LS	8			45.7	41.7		58.3	20.3	14.5		18.1						34									
VSC-L 15-8A8LS	8			R1/4	11		52.7	46.7	21		98.3			23.3	14.5	18.1	19			22	1.5	66		95	100	84
VSC-L 15-10A8LS	8			R3/8	12		52.7	46.4	20.7		98.3			23.3	14.5	18.1										19
VSC-L 15-8A10LS	10	R1/4	11	56.5	50.5	21	100.8	25.8	17.5	20.2	24	19	22	66	95	100	89									
VSC-L 15-10A10LS	10	R3/8	12	56.5	50.2	20.7	100.8	25.8	17.5	20.2							19	22	1.5	90						
VSC-L 20-8A8LS	8	R1/4	11	52.7	46.7	21	98.3	23.3	14.5	18.1	24	19	22				66	180	200	85.5						
VSC-L 20-10A8LS	8	R3/8	12	52.7	46.4	20.7	98.3	23.3	14.5	18.1										19	22		1.5			86.5
VSC-L 20-8A10LS	10	R1/4	11	56.5	50.5	21	100.8	25.8	17.5	20.2	24	19	22							66	180	200	90.5			
VSC-L 20-10A10LS	10	R3/8	12	56.5	50.2	20.7	100.8	25.8	17.5	20.2													19	22	1.5	91.5
VSC-E 07-6A6LS	6	R1/8	8	42.8	38.8	16	57.3	19.3	12.5	16	17	14	16	0.7	92	10.5							17	31.5		
VSC-E 07-6A8LS	8			45.7	41.7		58.3	20.3	14.5		18.1													34		
VSC-E 10-6A6LS	6			42.8	38.8		57.3	19.3	12.5		17						31.5									
VSC-E 10-6A8LS	8			45.7	41.7		58.3	20.3	14.5		18.1			34												
VSC-E 12-6A6LS	6			42.8	38.8		57.3	19.3	12.5		17			31.5												
VSC-E 12-6A8LS	8			45.7	41.7		58.3	20.3	14.5		18.1			34												
VSC-E 15-8A8LS	8	R1/4	11	52.7	46.7	21	98.3	23.3	14.5	18.1	19	22	1.5	92	42	70	86.5									
VSC-E 15-10A8LS	8	R3/8	12	52.7	46.4	20.7	98.3	23.3	14.5	18.1							19	22	1.5	87.5						
VSC-E 15-8A10LS	10	R1/4	11	56.5	50.5	21	100.8	25.8	17.5	20.2	24	19	22				92	42	70	91.5						
VSC-E 15-10A10LS	10	R3/8	12	56.5	50.2	20.7	100.8	25.8	17.5	20.2										19	22	1.5	92.5			
VSC-E 20-8A8LS	8	R1/4	11	52.7	46.7	21	98.3	23.3	14.5	18.1	24	19	22							92	84	150	91.5			
VSC-E 20-10A8LS	8	R3/8	12	52.7	46.4	20.7	98.3	23.3	14.5	18.1													19	22	1.5	92.5
VSC-E 20-8A10LS	10	R1/4	11	56.5	50.5	21	100.8	25.8	17.5	20.2	24	19	22	92	84	150							96.5			
VSC-E 20-10A10LS	10	R3/8	12	56.5	50.2	20.7	100.8	25.8	17.5	20.2													19	22	1.5	97.5

Note: L1, L2 and L3 dimensions are references applicable after screw tightening.

Ejector system

VSY

VSH-VSU
VSB-VSC

VSG

VSK
VSKM

VSJ
VSJM

VSX
VSXM

VSQ

VSZM

Dimensions

● VSC-*-*J (air supply port elbow type, common exhaust)

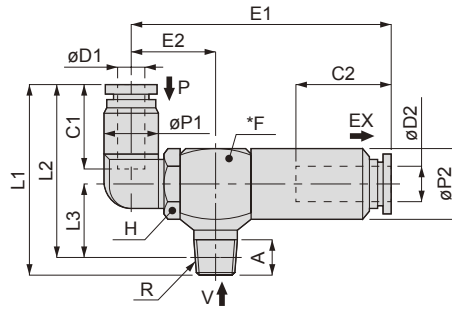

Unit: mm

Model no.	O.D. øD1	O.D. øD2	R	A	L1	L2	L3	E1	E2	øP1	øP2	C1	C2	Opposite side H	*F	Nozzle diameter (mm)	Ultimate vacuum (-kPa)	Suction flow (l/min. (ANR))	Air consumption (l/min. (ANR))	Weight (g)			
VSC-H 07-6A6LJ	6	8	R1/8	8	42.8	38.8	16	59.5	19.3	12.5	16	17	18.2	14	16	0.7	93	13	23	35.5			
VSC-H 07-6A8LJ	8				45.7	41.7		60.5	20.3	14.5		18.2								38			
VSC-H 10-6A6LJ	6				42.8	38.8		59.5	19.3	12.5		17								35.5			
VSC-H 10-6A8LJ	8				45.7	41.7		60.5	20.3	14.5		18.2								38			
VSC-H 12-6A6LJ	6				42.8	38.8		59.5	19.3	12.5		17								35.5			
VSC-H 12-6A8LJ	8				45.7	41.7		60.5	20.3	14.5		17								38			
VSC-H 15-8A8LJ	8	12	R1/4	11	52.7	46.7	21	88.1	23.3	14.5	22	18.2	19	22	1.5	93	63	100	97.5				
VSC-H 15-10A8LJ	8		R3/8	12	46.4	20.7	18.2	98.5															
VSC-H 15-8A10LJ	10		R1/4	11	56.5	50.5	21	90.6	25.8	17.5		20.2							102				
VSC-H 15-10A10LJ	10		R3/8	12	50.2	20.7	20.2	103															
VSC-H20-8A8LJ	8		R1/4	11	52.7	46.7	21	88.1	23.3	14.5		18.2							101.5				
VSC-H 20-10A8LJ	8		R3/8	12	46.4	20.7	2	93	110	200		102.5											
VSC-H 20-8A10LJ	10	R1/4	11	56.5	50.5	21	90.6	25.8	17.5	20.2	106.5												
VSC-H 20-10A10LJ	10	R3/8	12	50.2	20.7	2	93	110	200	107.5													
VSC-L 07-6A6LJ	6	8	R1/8	8	42.8	38.8	16	59.5	19.3	12.5	16	17	18.2	14	16	0.7	93	26	23	35.5			
VSC-L 07-6A8LJ	8				45.7	41.7		60.5	20.3	14.5		18.2								38			
VSC-L 10-6A6LJ	6				42.8	38.8		59.5	19.3	12.5		17								35.5			
VSC-L 10-6A8LJ	8				45.7	41.7		60.5	20.3	14.5		18.2								38			
VSC-L 15-8A8LJ	8				R1/4	11		52.7	46.7	21		88.1								23.3	14.5	18.2	95.5
VSC-L 15-10A8LJ	8				R3/8	12		46.4	20.7	18.2		96.5											
VSC-L 15-8A10LJ	10	R1/4	11	56.5	50.5	21	90.6	25.8	17.5	20.2	100.5												
VSC-L 15-10A10LJ	10	R3/8	12	50.2	20.7	20.2	101.5																
VSC-L 20-8A8LJ	8	R1/4	11	52.7	46.7	21	88.1	23.3	14.5	18.2	97												
VSC-L 20-10A8LJ	8	R3/8	12	46.4	20.7	2	93	180	200	98													
VSC-L 20-8A10LJ	10	R1/4	11	56.5	50.5	21	90.6	25.8	17.5	20.2	102												
VSC-L 20-10A10LJ	10	R3/8	12	50.2	20.7	2	93	180	200	103													
VSC-E 07-6A6LJ	6	8	R1/8	8	42.8	38.8	16	59.5	19.3	12.5	16	17	18.2	14	16	0.7	92	10.5	17	35.5			
VSC-E 07-6A8LJ	8				45.7	41.7		60.5	20.3	14.5		18.2								38			
VSC-E 10-6A6LJ	6				42.8	38.8		59.5	19.3	12.5		17								35.5			
VSC-E 10-6A8LJ	8				45.7	41.7		60.5	20.3	14.5		18.2								38			
VSC-E 12-6A6LJ	6				42.8	38.8		59.5	19.3	12.5		17								35.5			
VSC-E 12-6A8LJ	8				45.7	41.7		60.5	20.3	14.5		17								38			
VSC-E 15-8A8LJ	8	12	R1/4	11	52.7	46.7	21	88.1	23.3	14.5	22	18.2	19	22	1.5	92	42	70	98				
VSC-E 15-10A8LJ	8		R3/8	12	46.4	20.7	18.2	99															
VSC-E 15-8A10LJ	10		R1/4	11	56.5	50.5	21	90.6	25.8	17.5		20.2							103				
VSC-E 15-10A10LJ	10		R3/8	12	50.2	20.7	20.2	104															
VSC-E 20-8A8LJ	8		R1/4	11	52.7	46.7	21	88.1	23.3	14.5		18.2							103				
VSC-E 20-10A8LJ	8		R3/8	12	46.4	20.7	2	93	84	150		104											
VSC-E 20-8A10LJ	10	R1/4	11	56.5	50.5	21	90.6	25.8	17.5	20.2	108												
VSC-E 20-10A10LJ	10	R3/8	12	50.2	20.7	2	93	84	150	109													

Note: L1, L2 and L3 dimensions are references applicable after screw tightening.

Model no.

● Silencer element

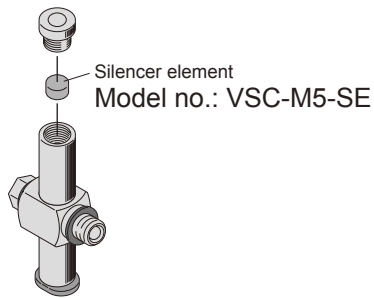

● Silencer kit
• VSC-*07, 10, 12

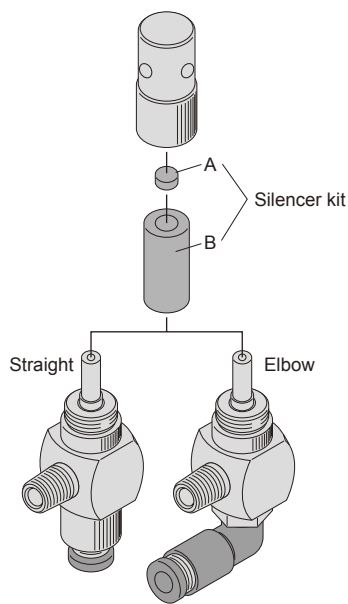

• VSC-*15, 20

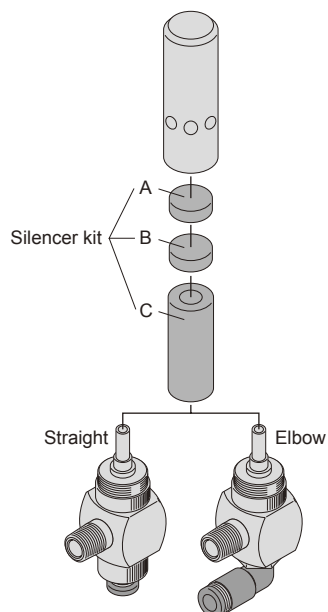

Silencer kit model no.	Vacuum ejector model no.
VSC-12-SK	VSC-*07-6A* (L) S
	VSC-*10-6A* (L) S
	VSC-*12-6A* (L) S

Silencer kit model no.	Vacuum ejector model no.
VSC-15-SK	VSC-*15-8A8* (L) S
	VSC-*15-10A8* (L) S
	VSC-*15-8A10* (L) S
	VSC-*15-10A10* (L) S
VSC-20-SK	VSC-*20-8A8* (L) S
	VSC-*20-10A8* (L) S
	VSC-*20-8A10* (L) S
	VSC-*20-10A10* (L) S

Ejector system

VSJ

VSH-VSU
VSB-VSC

VSG

VSK
VSKM

VSJ
VSJM

VSX
VSXM

VSQ

VSZM