

Guide with rated load approx. **1.5-fold** higher incorporated!

(Compared to similar $\phi 16$ product available commercially)

Innovative lubrication mechanism greatly improves life and operation stability.

High precision guided magnetic super rod-less cylinder high accuracy ($\phi 10, \phi 16, \phi 25$) boasts a high accuracy and high rigidity.

Workpiece installation on two faces

High repetition accuracy

Outstanding repetition accuracy attained with linear guide

Single face common piping possible (standard)

Low table design

This slim design has a low slide table height.

T switch with ample models mounted

Switch mounting face can be selected from two faces without any protrusion.

Direct mounting

Mount vertically or horizontally

Double durability.

(CKD comparison)

Lube-keeping structure

Textile (lube-keeping structure) impregnated with grease is mounted on the sliding section of the piston and slider, enabling stable long-term lubricant supply and preventing wear. Long life (more than double by CKD comparison) and stable operation are realized.

Lubrication supply/absorption function

A capillary tube applies impregnated grease evenly and regularly to the sliding surface, absorbing excess grease.

Dust wiper function

Dust and wear power from the packing, etc., are collected by the textile to reduce contamination on the sliding section.

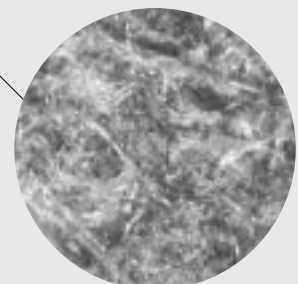

SCP*2
CMK2
CMA2
SCM
SCG
SCA2
SCS
CKV2
CA/OV2
SSD
CAT
MDC2
MVC
SMD2
MSD*
FC*
STK
ULK*
JSK/M2
JSG
JSC3
USSD
USC
JSB3
LMB
STG
STS/L
LCS
LCG
LCM
LCT
LCY
STR2
UCA2
HCM
HCA
SRL2
SRG
SRM
SRT
MRL2
MRG2
SM-25
CAC3
UCAC
RCC2
MFC
SHC
GLC
Ending

Series variation

Magnet type rodless cylinder high precision guide type MRG2 Series

●: Standard, ○: Option, ■: Not available

Variation	Model no.	Bore size (mm)	Standard stroke length (mm)								Min. stroke length (mm)	Max. stroke length (mm)	Option			Switch	Page	
			50	100	150	200	300	400	500	600			700	Brackets for full stroke adjustment on both ends	R side adjustable full-stroke with bracket			L side adjustable full-stroke with bracket
			■	■	■	■	■	■	■	■			A					
Double acting	MRG2 	φ 10	●	●	●	●	●	■	■	■	50	300						
		φ 16	●	●	●	●	●	●	●	■		500	○	○	○	○	2202	
		φ 25	●	●	●	●	●	●	●	●		700						

- SCP*2
- CMK2
- CMA2
- SCM
- SCG
- SCA2
- SCS
- CKV2
- CA/OV2
- SSD
- CAT
- MDC2
- MVC
- SMD2
- MSD*
- FC*
- STK
- ULK*
- JSK/M2
- JSG
- JSC3
- USSD
- USC
- JSB3
- LMB
- STG
- STS/L
- LCS
- LCG
- LCM
- LCT
- LCY
- STR2
- UCA2
- HCM
- HCA
- SRL2
- SRG
- SRM
- SRT
- MRL2
- MRG2**
- SM-25
- CAC3
- UCAC
- RCC2
- MFC
- SHC
- GLC
- Ending

Magnet rodless cylinder high precision guide types
Rodless type



Pneumatic components

Safety precautions

Always read this section before starting use.

Refer to Intro 71 for general precautions of the cylinder, and to Intro 78 for general precautions of the cylinder switch.

Rodless cylinder MRG2 Series

Design & Selection

WARNING

■ If the force of the cylinder changes because of torsion at the machine's sliding section, the table could pop out.

In this case, there is a risk of personal injury such as catching of arms or legs, and of machine damage. Always adjust for smooth machine movement, and provide a design that protects the workers from injury.

■ When requiring deceleration circuit and shock absorber. If the driven object's speed is fast or the weight is large, it may be difficult to absorb the impact just with the standard shock absorber. Provide a circuit which decelerates before the shock absorber, or use an external shock absorber to ease the impact. The machine's rigidity must also be carefully considered in this case.

■ The piston could separate if a load exceeding the allowable value is applied or if used at a pressure exceeding the maximum working pressure.

Installation & Adjustment

CAUTION

■ Check clearance between the end plate and slider. Avoid catching fingers or hands while the cylinder is moving.

■ Do not apply a load exceeding that allowed given in selection material to the cylinder.

■ Do not use with the table fixing. Use the cylinder with the end plate fixed. Avoid using at table fixing.

■ Install so the table moves at the minimum working pressure for the entire process.

If the cylinder installation surface is not flat, minimum working pressure rises due to twisting in the guide section, and may cause bearings to wear early. Install the table so it operates at minimum working pressure. The installation surface should be very flat, but if it cannot be confirmed, adjust with a shim, etc.

■ Do not scratch or dent the periphery of the cylinder tube. Lube-keeping structure, scraper, or slider wear ring may be damaged and result in operation faults.

■ The cylinder may malfunction if a magnetic substance, such as a steel plate, is nearby. Separate the cylinder or the magnetic sensor by the distance below.

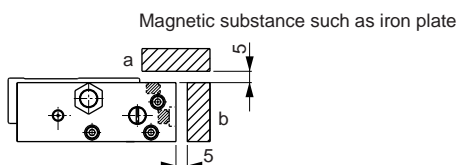

Avoid a, b simultaneous.

■ When using cylinders next to each other, or when using another magnetic sensor in the area, separate the cylinder or magnetic sensor from the slider surface by the distance shown below to prevent faults caused by the leakage field of the magnet in the cylinder.

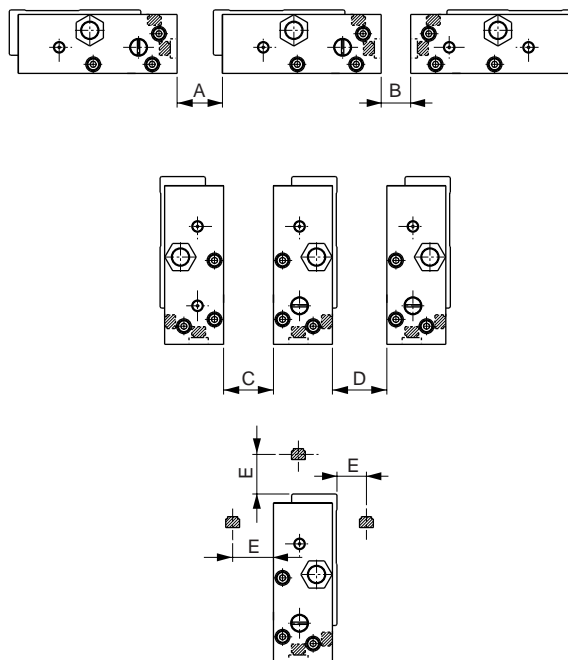

Unit: mm

Port size	A	B	C	D	E
φ 10	20	10	10	10	20
φ 16	20	10	10	10	20
φ 25	50	20	20	20	50

When less than dimension E, faults may be prevented by placing a magnetic object (2 mm or thicker steel plate) between the sensor and slider.

SCP*2
CMK2
CMA2
SCM
SCG
SCA2
SCS
CKV2
CA/OV2
SSD
CAT
MDC2
MVC
SMD2
MSD*
FC*
STK
ULK*
JSK/M2
JSG
JSC3
USSD
USC
JSB3
LMB
STG
STS/L
LCS
LCG
LCM
LCT
LCY
STR2
UCA2
HCM
HCA
SRL2
SRG
SRM
SRT
MRL2
MRG2
SM-25
CAC3
UCAC
RCC2
MFC
SHC
GLC
Ending

■ Piping port position and operational direction

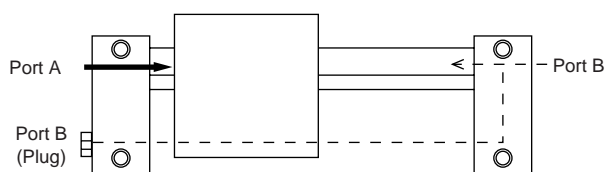

When the port A is pressurized, the slide table will move to the right as shown in the figure.

When the port B is pressurized, the slide table will move to the left as shown in the figure.

The port B (plug) is sealed with a plug when shipped. Common piping can be used by removing the plug and sealing the right port B.

■ The CKD shock absorber is treated as a consumable.

Replace the shock absorber if energy absorption performance drops or if movement is no longer smooth.

■ Adjustable stroke method

Stroke (-) direction ↔ Stroke (+) direction

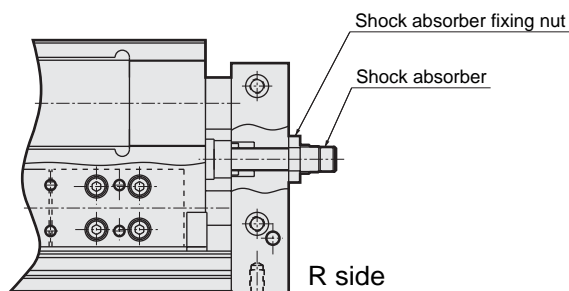

Adjustable stroke length (single)

Bore size (mm)	Stroke length (-) direction	Stroke length (+) direction
φ 10	5	5
φ 16	5	5
φ 25	6	4

1. Loosen the shock absorber fixing nut, turn the shock absorber so that the slide table comes to the target position. After adjusting, tighten the shock absorber fixing nut with the tightening torque shown right.

CAUTION

The stroke can be adjusted to the values shown above by adjusting the shock absorber, but when adjusting in the stroke (+) direction, special care is required as the switch detection will be disabled at the stroke end only on the R side.

■ Adjustable full-stroke bracket adjustment method

Stroke (-) direction ↔ Stroke (+) direction

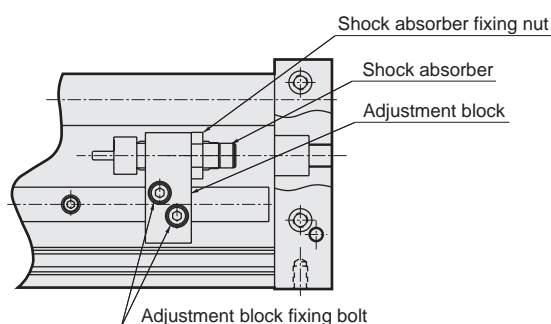

Adjustable full-stroke volume (adjust amount per adjustable full-stroke bracket 1 pc.)

Bore size (mm)	A		A1		A2	
	Stroke length (-) direction	Stroke length (+) direction	Stroke length (-) direction	Stroke length (+) direction	Stroke length (-) direction	Stroke length (+) direction
φ 10	Stroke length	0	Stroke length	24	Stroke length	24
φ 16	Stroke length	0	Stroke length	24	Stroke length	24
φ 25	Stroke length	15	Stroke length	65	Stroke length	65

1. Movement of adjustment block

Loosen the adjustment block fixing bolt, move to a random position, and tighten the adjustment block fixing bolts with the tightening torque shown below.

2. Fine adjustment of shock absorber

Loosen the shock absorber fixing nut, turn the shock absorber so that the slide table comes to the target position. After adjusting, tighten the shock absorber fixing nut with the tightening torque shown below.

Tightening torque	Shock absorber fixing nut (N·m)	Adjustment block fixing bolt (N·m)
φ 10	12 to 20	22 to 30
φ 16	30 to 40	22 to 30
φ 25	45 to 60	46 to 63

During Use & Maintenance

⚠ CAUTION

- A magnetic force of integrated magnet is powerful. Do not disassemble the product.

SCP*2
CMK2
CMA2
SCM
SCG
SCA2
SCS
CKV2
CA/OV2
SSD
CAT
MDC2
MVC
SMD2
MSD*
FC*
STK
ULK*
JSK/M2
JSG
JSC3
USSD
USC
JSB3
LMB
STG
STS/L
LCS
LCG
LCM
LCT
LCY
STR2
UCA2
HCM
HCA
SRL2
SRG
SRM
SRT
MRL2
MRG2
SM-25
CAC3
UCAC
RCC2
MFC
SHC
GLC
Ending

Magnet rodless cylinder high precision guide types
Rodless type

Magnet rodless cylinder high precision guide types

MRG2 Series

Bore size: ϕ 10, ϕ 16, ϕ 25

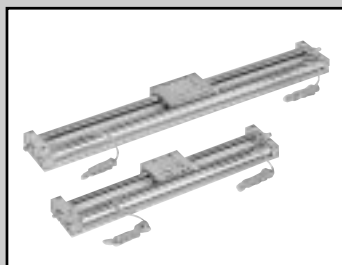

JIS symbol

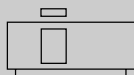

Specifications

Descriptions	MRG2		
	ϕ 10	ϕ 16	ϕ 25
Bore size mm	ϕ 10	ϕ 16	ϕ 25
Actuation	Double acting		
Working fluid	Compressed air		
Max. working pressure MPa	0.7		
Min. working pressure MPa	0.3 (note)	0.2	
Withstanding pressure MPa	1.05		
Ambient temperature $^{\circ}$ C	5 to 60		
Port size	M5		Rc1/8
Stroke tolerance mm	+1.5 0		
Working piston speed mm/s	50 to 1000		
Cushion	Shock absorber		
Lubrication	Not required (when lubricating, use turbine oil ISO VG32.)		
Magnet holding force N	63	166	350
Allowable energy absorption J	2.1	5.3	8.7

Note: The shock absorber resistance may increase the time to reach the stroke end. Take this into consideration when using this cylinder.

Note: Other than standard stroke length is custom order.

Stroke length

Bore size (mm)	Standard stroke length (mm)	Max. stroke length (mm)	Min. stroke length (mm)	Min. stroke length with switch (mm)
ϕ 10	50, 100, 150, 200, 300	300	50	50 (If 2 installed)
ϕ 16	50, 100, 150, 200, 300, 400, 500	500		
ϕ 25	50, 100, 150, 200, 300, 400, 500, 600, 700	700		

Note: Other than standard stroke length is custom order.

- SCP*2
- CMK2
- CMA2
- SCM
- SCG
- SCA2
- SCS
- CKV2
- CA/OV2
- SSD
- CAT
- MDC2
- MVC
- SMD2
- MSD*
- FC*
- STK
- ULK*
- JSK/M2
- JSG
- JSC3
- USSD
- USC
- JSB3
- LMB
- STG
- STS/L
- LCS
- LCG
- LCM
- LCT
- LCY
- STR2
- UCA2
- HCM
- HCA
- SRL2
- SRG
- SRM
- SRT
- MRL2
- MRG2**
- SM-25
- CAC3
- UCAC
- RCC2
- MFC
- SHC
- GLC
- Ending

Switch specifications

- 1 color/2 color indicator

*The T0/T5 switch can be used with 220 VAC.
Consult with CKD for working conditions.

Descriptions	Proximity 2 wire			Proximity 3 wire			Reed 2 wire			
	T1H/T1V	T2H/T2V	T2YH/T2YV	T3H/T3V	T3PH/T3PV (Custom order)	T3YH/T3YV	T0H/T0V		T5H/T5V	
Applications	Programmable controller, relay, small solenoid valve	Programmable controller		Programmable controller			Programmable controller		Programmable controller, relay, IC circuit (w/o light), serial connection	
Output method	-			NPN output	PNP output	NPN output	-			
Power voltage	-			10 to 28 VDC			-			
Load voltage	85 to 265 VAC	10 to 30 VDC		30 VDC or less			12/24 VDC	110 VAC	5/12/24 VDC	110 VAC
Load current	5 to 100mA	5 to 20mA (Note 1)		100mA or less		50mA or less	5 to 50mA	7 to 20mA	50mA or less	20mA or less
Light	LED (ON lighting)	LED (ON lighting)	Red/green LED (ON lighting)	LED (ON lighting)	Green LED (ON lighting)	Red/green LED (ON lighting)	LED (ON lighting)		Without indicator light	
Leakage current	1mA or less with 100 VAC 2mA or less with 200 VAC	1mA or less		10 μA or less			0mA			

- With preventive maintenance output

Descriptions	Proximity 3 wire		Proximity 4 wire		Proximity 3 wire		Proximity 4 wire			
	T2YFH/V		T3YFH/V		T2YMH/V		T3YMH/V			
Applications	Programmable controller		Programmable controller		Programmable controller		Programmable controller			
Output method	NPN output									
Light	Red/green LED (ON lighting)									
	Installation position adjustment section	-			Yellow LED (ON lighting)					
Regular	Preventive maintenance output		-		-					
	Power voltage	-		10 to 28 VDC		-		10 to 28 VDC		
	Load voltage	10 to 30 VDC		30 VDC or less		10 to 30 VDC		30 VDC or less		
	Load current	5 to 20mA		50mA or less		5 to 20mA		50mA or less		
Preventive maintenance output	Leakage current		1mA or less		10 μA or less		1.2mA or less		10 μA or less	
	Load voltage	30 VDC or less								
	Load current	20mA or less		50mA or less		5 to 20mA or less		50mA or less		
Leakage current		10 μA or less								

Note 1: Refer to Ending 1 for other switch specifications.

Note 2: Maximum load current above: 20mA at 25°C. The current will be lower than 20mA if ambient temperature around switch is higher than 25°C.
(5 to 10mA when 60°C)

Cylinder weight

Unit (g)

Type	Without switch		Weight of adjustable full-stroke bracket (per 1)
	Weight when stroke length 0mm	Additional weight per S = 100mm	
MRG2-10	610	180	75
MRG2-16	1170	280	110
MRG2-25	3270	490	200

SCP*2
CMK2
CMA2
SCM
SCG
SCA2
SCS
CKV2
CA/OV2
SSD
CAT
MDC2
MVC
SMD2
MSD*
FC*
STK
ULK*
JSK/M2
JSG
JSC3
USSD
USC
JSB3
LMB
STG
STS/L
LCS
LCG
LCM
LCT
LCY
STR2
UCA2
HCM
HCA
SRL2
SRG
SRM
SRT
MRL2
MRG2
SM-25
CAC3
UCAC
RCC2
MFC
SHC
GLC

Ending

Magnet rodless cylinder high precision guide types
Rodless type

How to order

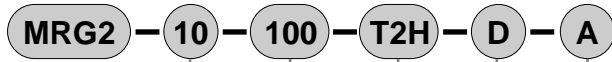

A Bore size

B Stroke length

C Switch model no.
* indicates lead wire length.
Note 3

D Switch quantity

E Option
Note 4

- SCP*2
- CMK2
- CMA2
- SCM
- SCG
- SCA2
- SCS
- CKV2
- CA/OV2
- SSD
- CAT
- MDC2
- MVC
- SMD2
- MSD*
- FC*
- STK
- ULK*
- JSK/M2
- JSG
- JSC3
- USSD
- USC
- JSB3
- LMB
- STG
- STS/L
- LCS
- LCG
- LCM
- LCT
- LCY
- STR2
- UCA2
- HCM
- HCA
- SRL2
- SRG
- SRM
- SRT
- MRL2
- MRG2**
- SM-25
- CAC3
- UCAC
- RCC2
- MFC
- SHC
- GLC
- Ending

Symbol	Descriptions			
A Bore size (mm)				
10	ϕ 10			
16	ϕ 16			
25	ϕ 25			
B Stroke length (mm)				
	Bore size ϕ (mm)	10	16	25
50	50	●	●	●
100	100	●	●	●
150	150	●	●	●
200	200	●	●	●
300	300	●	●	●
400	400		●	●
500	500		●	●
600	600			●
700	700			●
C Switch model no.				
Radial lead wire	Axial lead wire	Contact	Indication	Lead wire
T0H*	T0V*	Reed	1 color indicator type	2-wire
T5H*	T5V*		Without indicator light	
T1H*	T1V*		1 color indicator type	
T2H*	T2V*	Proximity	1 color indicator type (custom order)	
T3PH*	T3PV*		2 color indicator type	2-wire
T2YH*	T2YV*		2 color indicator type (w/o indicator light for preventive maintenance output)	3-wire
T3YH*	T3YV*		2 color indicator type (w/ indicator light for preventive maintenance output (1 color))	4-wire
T2YFH*	T2YFV*			3-wire
T3YFH*	T3YFV*			4-wire
T2YMH*	T2YMV*			3-wire
T3YMH*	T3YMV*			4-wire
*Lead wire length				
Blank	1m (standard)			
3	3m (option)			
5	5m (option)			
D Switch quantity				
R	One on R side (Note 1)			
L	One on L side (Note 1)			
D	Two			
T	Three			
4	Four (when more than 4 switches, indicate switch quantity.)			
E Option				
A	Brackets for full stroke adjustment on both ends			
A1	R side adjustable full-stroke with bracket (Note 2)			
A2	L side adjustable full-stroke with bracket (Note 2)			

Note on model no. selection

Note1: Refer to the switch installation position dimensions (page 2207) for the R side and L side.

Note2: Refer to page 2208 for the positions of R side and L side stroke adjustment fittings.

Note3: T type switches other than switch model no. are available. (Custom order) Refer to Ending 1 for the details.

Note4: The adjustable full-stroke bracket cannot be retrofitted

<Example of model number>

MRG2-10-100-T2H-D-A

Model: Rodless cylinder high precision guide type

A Bore size : ϕ 10mm

B Stroke length : 100mm

C Switch model no. : Proximity switch T2H

D Switch quantity : Two

E Option : Brackets for full stroke adjustment on both ends

How to order switch

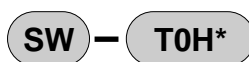

Switch model no.
(Item **C** above)

How to order discrete shock absorber

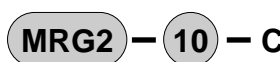

Bore size
(Item **A** above)

Internal structure and parts list

● MRG2 (high precision guide type)

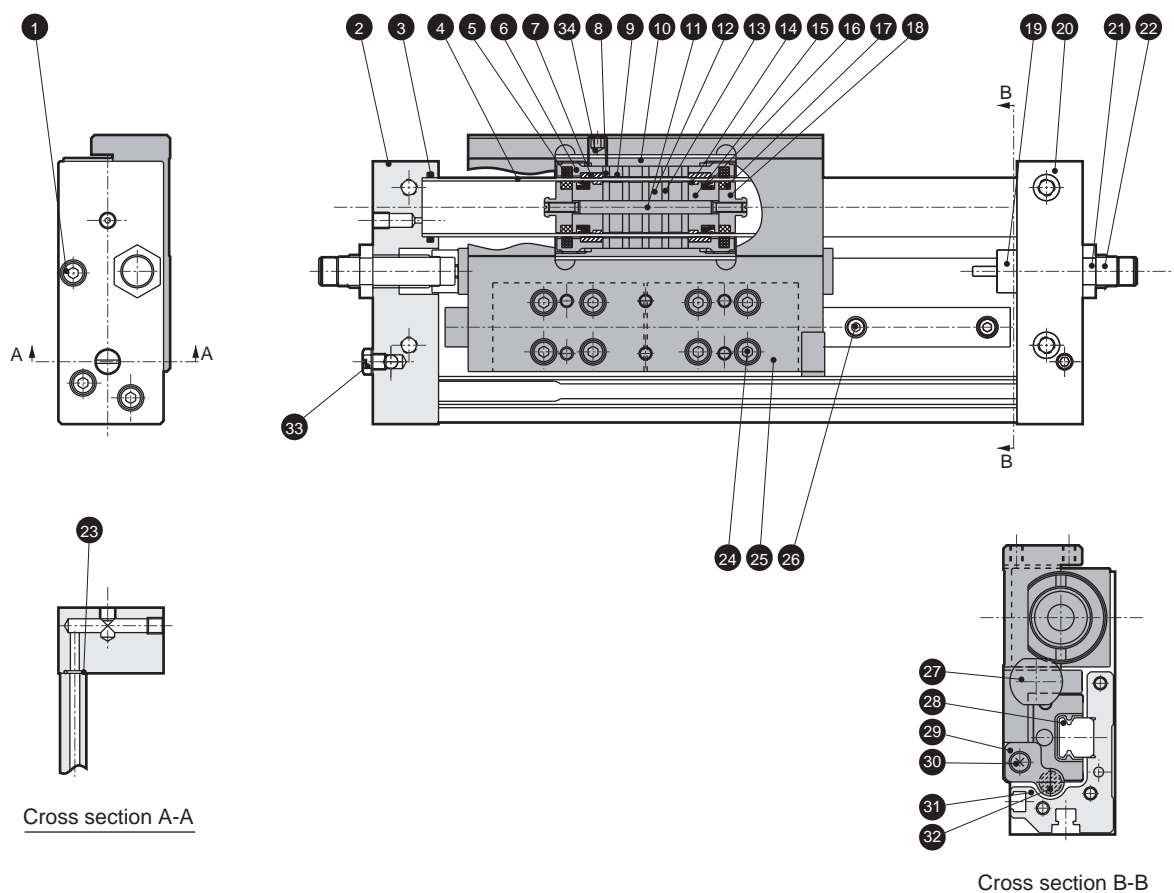

SCP*2
CMK2
CMA2
SCM
SCG
SCA2
SCS
CKV2
CA/OV2
SSD
CAT
MDC2
MVC
SMD2
MSD*
FC*
STK
ULK*
JSK/M2
JSG
JSC3
USSD
USC
JSB3
LMB
STG
STS/L
LCS
LCG
LCM
LCT
LCY
STR2
UCA2
HCM
HCA
SRL2
SRG
SRM
SRT
MRL2
MRG2
SM-25

MRG2 (high precision guide type)

No.	Parts name	Material	Remarks	No.	Parts name	Material	Remarks
1	Hexagon socket head cap bolt	Stainless steel		18	Piston (2)	Aluminum alloy	Chromate
2	End plate (L)	Aluminum alloy	Alumite	19	Stopper cap	Stainless steel	
3	O ring	Nitrile rubber		20	End plate (R)	Aluminum alloy	Alumite
4	Cylinder tube	Stainless steel		21	Hexagon nut	Steel	Galvanizing
5	Lube keeping structure (slider)	Special rubber		22	Shock absorber		
6	Slider guard	Aluminum alloy	Chromate	23	O ring	Nitrile rubber	
7	Slider wear ring	Polyacetal resin		24	Hexagon socket head cap bolt	Stainless steel	
8	Slider yoke	Steel	Galvanizing	25	Table	Aluminum alloy	Alumite
9	Magnet	Special alloy		26	Hexagon socket head cap bolt	Stainless steel	
10	Slider	Aluminum alloy	Chromate	27	Rod receiving	Stainless steel	
11	Piston shaft	Stainless steel		28	Linear guide		
12	Magnet	Special alloy		29	Magnet holder	Polyacetal resin	
13	Piston yoke	Steel	Galvanizing	30	Cross headed pan	Stainless steel	
14	Piston wear ring	Polyacetal resin		31	Base	Aluminum alloy	Alumite
15	Piston (1)	Aluminum alloy	Chromate	32	Magnet	Special alloy	
16	Piston packing seal	Nitrile rubber		33	Plug	Copper alloy or steel	
17	Lube keeping structure (piston)	Special rubber		34	Hexagon socket head set screw	Stainless steel	Only φ 25

Magnet rodless cylinder high precision guide types
Rodless type

Dimensions



● MRG2 (high precision guide type)

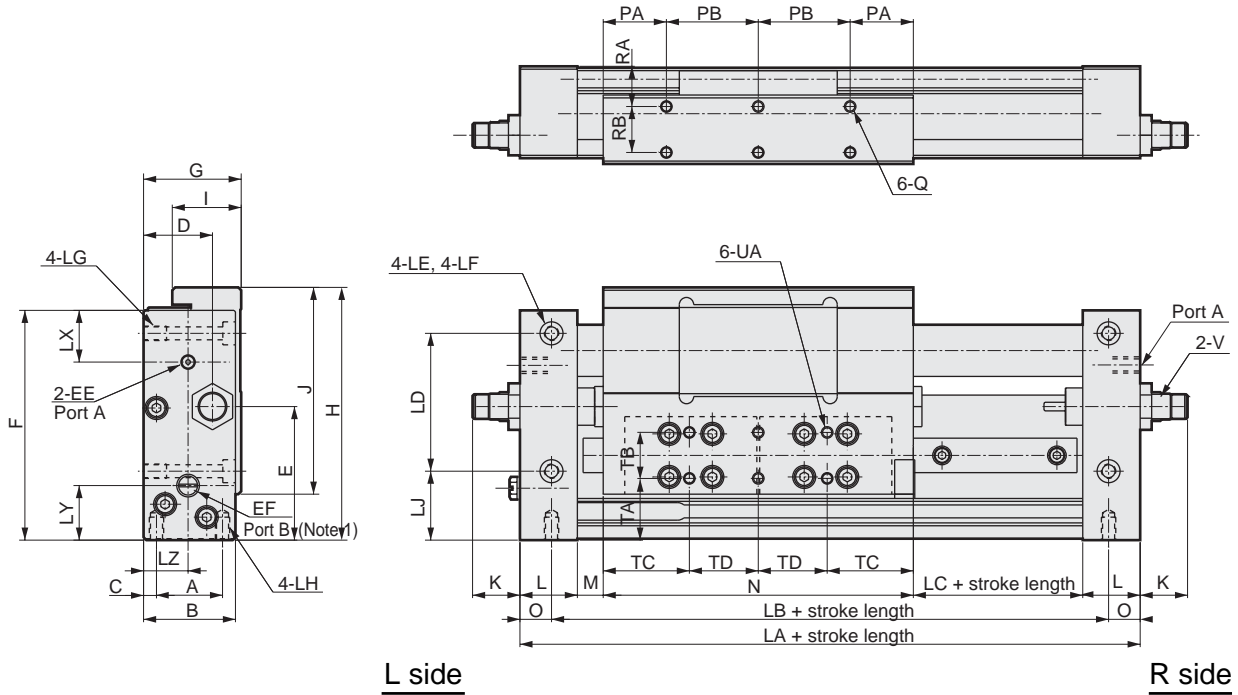

Symbol	Dimensions					Installation dimensions										
	LA	B	G	F	H	O	LB	LD	LJ	LE	LF	LG	LH			
Bore size (mm)																
φ 10	138	26	28	70	74	11	116	40	22	φ 4.5	8 spot face depth 4.4	M5 depth 8	M4 depth 8			
φ 16	166	32	34	80	88	11	144	48	24	φ 4.5	8 spot face depth 4.4	M5 depth 8	M5 depth 8			
φ 25	214	44	46	100	114	15	184	62	32	φ 5.5	9.5 spot face depth 5.4	M6 depth 12	M6 depth 10			
Symbol	Installation dimensions															
	A	C	PA	PB	RA	RB	Q	TA	TB	TC	TD	UA				
Bore size (mm)																
φ 10	18	4	16	24	12	12	M4 depth 6	19.5	13	24	16	M4 depth 6				
φ 16	23	4.5	22	32	14	16	M4 depth 6	21.5	16	30	24	M4 depth 6				
φ 25	23	5.5	34	40	20	20	M6 depth 8	23	22	38	36	M6 depth 8				
Symbol	General dimensions															
	D	LX	EE	LY	EF	LZ	E	I	J	K	L	M	N	LC	V	
Bore size (mm)																
MRG2	φ 10	19	18	M5 depth 4	17	M5 depth 4	11.5	38.5	20	58	14	20	9	80	9	MRG2-10-C
SM-25	φ 16	24	18	M5 depth 4	19	M5 depth 4	15	46.5	24	72	16.5	20	9	108	9	MRG2-16-C
CAC3	φ 25	32.5	23	Rc1/8	21.5	Rc1/8	23	55	32	98	19	25	8	148	8	MRG2-25-C

Note 1: When using the single face common piping, remove the plug from the port B and attach that plug to the R side port A.

- SCP*2
- CMK2
- CMA2
- SCM
- SCG
- SCA2
- SCS
- CKV2
- CA/OV2
- SSD
- CAT
- MDC2
- MVC
- SMD2
- MSD*
- FC*
- STK
- ULK*
- JSK/M2
- JSG
- JSC3
- USSD
- USC
- JSB3
- LMB
- STG
- STS/L
- LCS
- LCG
- LCM
- LCT
- LCY
- STR2
- UCA2
- HCM
- HCA
- SRL2
- SRG
- SRM
- SRT
- MRL2
- MRG2
- SM-25
- CAC3
- UCAC
- RCC2
- MFC
- SHC
- GLC
- Ending

Switch installation position dimensional drawing

● MRG2- (switch: T0H/V, T5H/V, T2H/V, T3H/V)

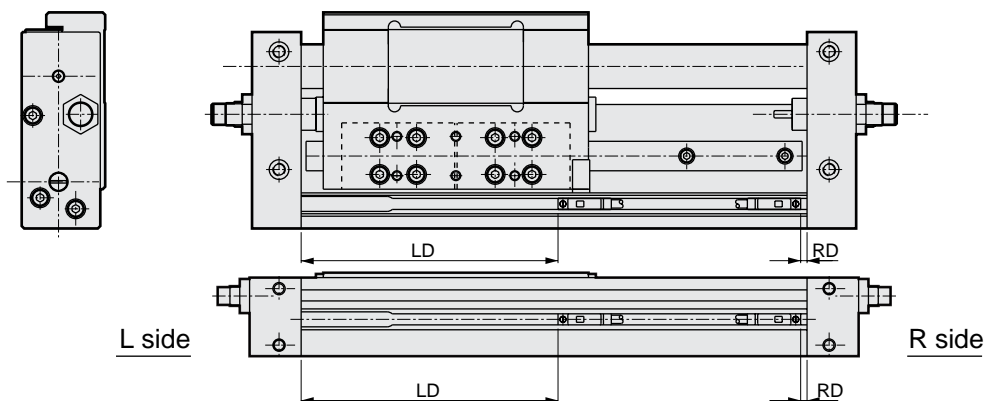

Symbol	Bore size (mm)	T0 H/V, T5 H/V		T2 H/V, T3 H/V	
		RD	LD	RD	LD
MRG2	φ 10	1.5	75.5	2.5	76.5
	φ 16	1.5	103.5	2.5	104.5
	φ 25	0.5	142.5	1.5	143.5
MRG2*-A	φ 10	26.5	100.5	27.5	101.5
	φ 16	26.5	128.5	27.5	129.5
	φ 25	50.5	192.5	51.5	193.5
MRG2*-A1	φ 10	51.5	75.5	52.5	76.5
	φ 16	51.5	103.5	52.5	104.5
	φ 25	100.5	142.5	101.5	143.5
MRG2*-A2	φ 10	1.5	125.5	2.5	126.5
	φ 16	1.5	153.5	2.5	154.5
	φ 25	0.5	242.5	1.5	243.5

● MRG2- (switch: T1H/V, T2Y*H/V, T3Y*H/V)

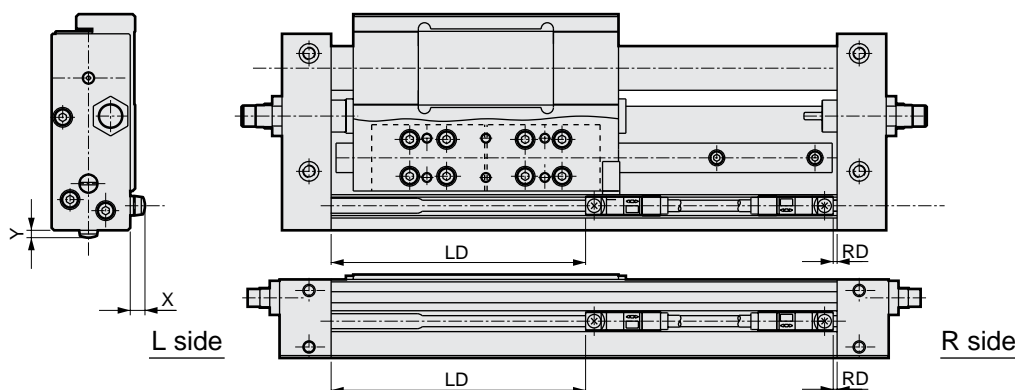

Symbol	Bore size (mm)	T2Y*H/V, T3Y*H/V			
		RD	LD	X	Y
MRG2	φ 10	1.5	75.5	6 (11.5)	3 (8.5)
	φ 16	1.5	103.5	6 (11.5)	3 (8.5)
	φ 25	0.5	142.5	6 (11.5)	3 (8.5)
MRG2*-A	φ 10	26.5	100.5	6 (11.5)	3 (8.5)
	φ 16	26.5	128.5	6 (11.5)	3 (8.5)
	φ 25	50.5	192.5	6 (11.5)	3 (8.5)
MRG2*-A1	φ 10	51.5	75.5	6 (11.5)	3 (8.5)
	φ 16	51.5	103.5	6 (11.5)	3 (8.5)
	φ 25	100.5	142.5	6 (11.5)	3 (8.5)
MRG2*-A2	φ 10	1.5	125.5	6 (11.5)	3 (8.5)
	φ 16	1.5	153.5	6 (11.5)	3 (8.5)
	φ 25	0.5	242.5	6 (11.5)	3 (8.5)

Note 1: Values in parentheses apply for the T1H/V and preventive maintenance output type.

SCP*2
CMK2
CMA2
SCM
SCG
SCA2
SCS
CKV2
CA/OV2
SSD
CAT
MDC2
MVC
SMD2
MSD*
FC*
STK
ULK*
JSK/M2
JSG
JSC3
USSD
USC
JSB3
LMB
STG
STS/L
LCS
LCG
LCM
LCT
LCY
STR2
UCA2
HCM
HCA
SRL2
SRG
SRM
SRT
MRL2
MRG2
SM-25
CAC3
UCAC
RCC2
MFC
SHC
GLC

Ending

Magnet rodless cylinder high precision guide types
Rodless type

Dimensions



- SCP*2
- CMK2
- CMA2
- SCM
- SCG
- SCA2
- SCS
- CKV2
- CA/OV2
- SSD
- CAT
- MDC2
- MVC
- SMD2
- MSD*
- FC*
- STK
- ULK*
- JSK/M2
- JSG
- JSC3
- USSD
- USC
- JSB3
- LMB
- STG
- STS/L
- LCS
- LCG
- LCM
- LCT
- LCY
- STR2
- UCA2
- HCM
- HCA
- SRL2
- SRG
- SRM
- SRT
- MRL2
- MRG2**
- SM-25
- CAC3
- UCAC
- RCC2
- MFC
- SHC
- GLC
- Ending

● MRG2-*-A (high precision guide type, brackets for full stroke adjustment on both ends)

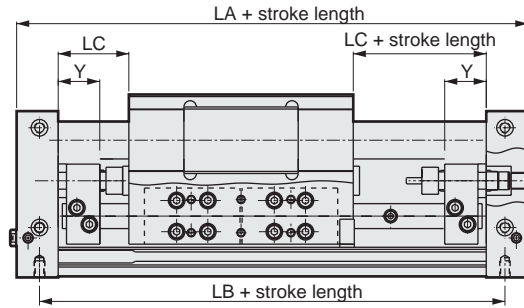

● MRG2-*-A1 (high precision guide type, R side adjustable full-stroke with bracket)

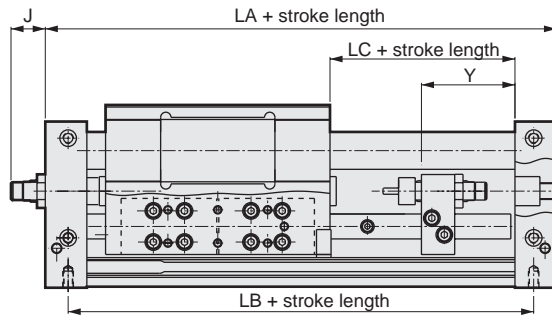

● MRG2-*-A2 (high precision guide type, L side adjustable full-stroke with bracket)

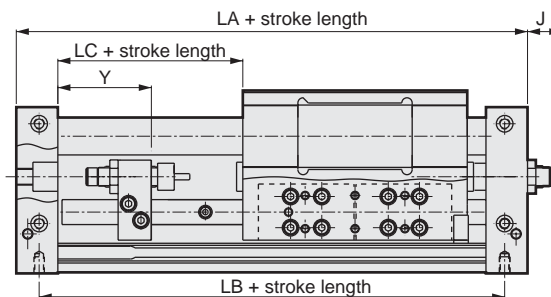

Symbol	LA			LB			LC			Y			J		
	A	A1	A2	A	A1	A2	A	A1	A2	A	A1	A2	A	A1	A2
φ 10	188			166			34	59		20	45		-	14	
φ 16	216			194			34	59		20	45		-	16.5	
φ 25	314			284			58	108		41	91		-	19	

MRG2 Series selection guide

● Selecting conditions are different from general cylinders. Please check if the proper product is selected according to selection guide.

SCP*2
CMK2
CMA2
SCM
SCG
SCA2
SCS
CKV2
CA/OV2
SSD
CAT
MDC2
MVC
SMD2
MSD*
FC*
STK
ULK*
JSK/M2
JSG
JSC3
USSD
USC
JSB3
LMB
STG
STS/L
LCS
LCG
LCM
LCT
LCY
STR2
UCA2
HCM
HCA
SRL2
SRG
SRM
SRT
MRL2
MRG2
SM-25
CAC3
UCAC
RCC2
MFC
SHC
GLC
Ending

Magnet rodless cylinder high precision guide types
Rodless type

STEP-1

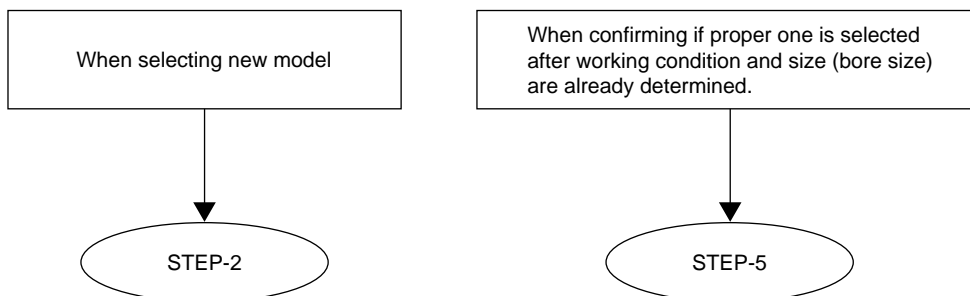

STEP-2

● Working conditions confirmation

1. Working pressure (P) (MPa)
2. Load (W) (N) (Load = workpiece load + jig load)
3. Installation attitude Width/Height (Refer to the following diagram " fig.1")
4. Stroke length (L) (m)
5. Moving time (t) (S)
6. Average speed (Va) (m/s)

Formula of cylinder average speed Va

$$Va = \frac{L}{t} \text{ (m/s)}$$

<Installation attitude>

Operation direction : horizontal, vertical-up, vertical-down

Installation attitude : width, height (refer to the Fig.1)

Fig.1

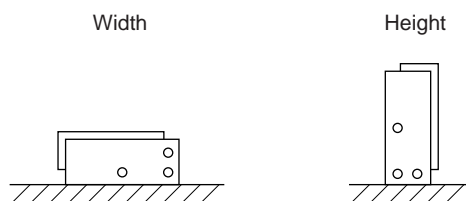

STEP-3

● Calculating required thrust

Calculate the cylinder required thrust (FN)

1. At horizontal operation

$$F_N = W \times 0.2^* = \text{[] (N)}$$

2. At vertical operation

$$F_N = W = \text{[] (N)}$$

* This is a frictional resistance value such as guide section, etc., when the load was put on the slider. Special consideration is required when a separate resistor is provided externally.

STEP-4

● Roughly selecting cylinder size

$$\text{Cylinder required thrust } F_N \leq \text{theoretical thrust} \times \frac{\mu}{100} \times \frac{\alpha}{100}$$

μ : Thrust efficiency (%) (Refer to the Fig.2.)

α : Load factor (%) (Refer to the Table 2.)

Select a cylinder size which satisfies these conditions.

Table 1. Theoretical thrust

Bore size (mm)	Working pressure MPa					
	0.2	0.3	0.4	0.5	0.6	0.7
$\phi 10$	-	24	31	39	47	55
$\phi 16$	40	60	80	101	121	139
$\phi 25$	98	147	196	245	295	339

Fig.2. Thrust efficiency μ

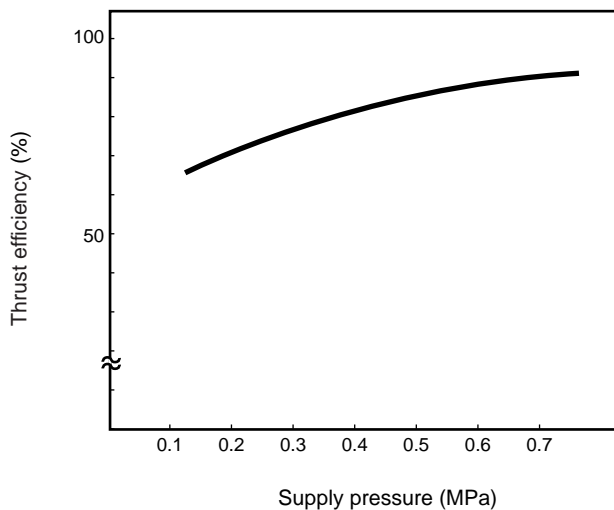

Load factor α : should be within the range of the following Table 2 for general use.

Table 2. Reference of load factor

Working pressure MPa	α (%)
0.2 to 0.3	$\alpha \leq 40$
0.3 to 0.6	$\alpha \leq 50$
0.6 to 0.7	$\alpha \leq 60$

- SCP*2
- CMK2
- CMA2
- SCM
- SCG
- SCA2
- SCS
- CKV2
- CA/OV2
- SSD
- CAT
- MDC2
- MVC
- SMD2
- MSD*
- FC*
- STK
- ULK*
- JSK/M2
- JSG
- JSC3
- USSD
- USC
- JSB3
- LMB
- STG
- STS/L
- LCS
- LCG
- LCM
- LCT
- LCY
- STR2
- UCA2
- HCM
- HCA
- SRL2
- SRG
- SRM
- SRT
- MRL2
- MRG2**
- SM-25
- CAC3
- UCAC
- RCC2
- MFC
- SHC
- GLC
- Ending

Magnet rodless cylinder high precision guide types
Rodless type

STEP-5

● Calculation of vertical load and each moment value

Calculate vertical load ($W1$, 2), and moment ($M1$, $M2$, $M3$) according to cylinder installation conditions of load.

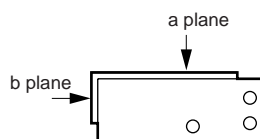

	a plane installation	b plane installation	Calculation result
Vertical load $W1$ $W2$			$W1 =$ <input type="text"/> $W2 =$ <input type="text"/>
Bending moment $M1 = F1 \times \ell_1$			$M1 =$ <input type="text"/>
Radial moment $M2 = F2 \times \ell_2$			$M2 =$ <input type="text"/>
Twist moment $M3 = F3 \times \ell_3$			$M3 =$ <input type="text"/>

Table 3. Each parameter value

Bore size (mm)	C	D
$\phi 10$	0.016	0.012
$\phi 16$	0.020	0.014
$\phi 25$	0.026	0.020

(m)

STEP-6

● Confirming vertical load and each composite moment

Divide each load by the value on Table 4 to find moment ratio, and confirm if the total is 1.0 or less.

$$\frac{W1 \text{ (or } W2)}{W1 \text{ (or } W2) \text{ max.}} + \frac{M1}{M1\text{max}} + \frac{M2}{M2\text{max}} + \frac{M3}{M3\text{max}} \leq 1.0$$

If the total is larger than 1.0

1. Reexamine load → STEP-2
2. Review cylinder bore size etc. as selecting large bore size. → Increase cylinder bore size
STEP-5

Table 4. Vertical load, maximum allowable value of each moment

Bore size (mm)	W1max. (N)	W2max. (N)	M1max. (N·m)	M2max. (N·m)	M3max. (N·m)
φ 10	44	35	2.2	1.2	2.2
φ 16	103	91	7.4	3.2	7.4
φ 25	176	176	18.3	7.3	18.3

STEP-7

● Kinetic energy confirmation

Calculate the kinetic energy from the load weight m (kg) and speed V (m/s), and make sure that it is within the specified range for the shock absorber.

If the specifications are exceeded, increase the cylinder size or consider installing an external damper.

(1) Formula of kinetic energy

$$E_1 = \frac{1}{2} \times m \times V^2 = \text{ } \text{ (J)}$$

E_1 : Kinetic energy (J)

$$m = \frac{W}{9.8} = \text{ } \text{ (kg)}$$

m : Load weight (kg)

V : Speed (m/s)

W : Load (N)

$$V = \frac{L}{t} \times \left[1 + 1.5 \times \frac{\alpha}{100} \right] = \text{ } \text{ (m/s)}$$

L : Cylinder stroke (m)

t : Operation time (s)

$$\alpha = \frac{F_N}{\text{Cylinder theoretical thrust} \times \frac{\mu}{100}} \times 100 = \text{ } \text{ (%)}$$

α : Cylinder load factor (%)

F_N : Required thrust (N)

μ : Thrust efficiency (%)

(2) Shock absorber

Table 5 shows shock absorbers used for MRG2.

Table 5. Specifications of shock absorber

Model	MRG2-10	MRG2-16	MRG2-25
Shock absorber model no.	MRG2-10-C (NCK-00-0.3 used)	MRG2-16-C (NCK-00-0.7 used)	MRG2-25-C (NCK-00-1.2 used)
Maximum energy absorption (J) ^{Note 1}	2.1	5.3	8.7
Stroke length (mm) ^{Note 1}	5	7	8.5
Energy absorption per hour (J/Hr)	6.3	12.6	21.6
Max. repeating cycle (time/min)	35	30	30

Note 1) The movement is stopped just before the stroke end with a stopper cap, so the energy and stroke are smaller than the standard product.

● Confirming allowable colliding energy of shock absorber

Calculate colliding object equivalent weight Me , and colliding energy E according to the formula on the table below, and confirm if Me and E should not be greater than the allowable values of Fig.4, Table 5. Also, refer to Table 5 to check if specifications of repeat frequency should be allowable values or less.

● Symbol

E : Colliding energy	<input type="text"/>	(J)
Me : Colliding object equivalent weight	<input type="text"/>	(kg)
m : Load weight	<input type="text"/>	(kg)
F : Cylinder thrust	<input type="text"/>	(N)
V : Colliding speed	<input type="text"/>	(m/s)
St : Stroke of shock absorber	<input type="text"/>	(m)
g : Gravity acceleration	9.8	(m/s ²)

	Horizontal movement	Moving downward	Moving upward
Applications			
Colliding object equivalent weight Me (kg)	$Me = m + \frac{2F \cdot St}{V^2}$	$Me = m + \frac{2 \cdot St (F + mg)}{V^2}$	$Me = m + \frac{2 \cdot St (F - mg)}{V^2}$
Energy E (J)	$E = \frac{mV^2}{2} + F \cdot St$	$E = \frac{mV^2}{2} + (F + mg) \cdot St$	$E = \frac{mV^2}{2} + (F - mg) \cdot St$

Fig. 4 Vp-Me characteristics (colliding speed-colliding object equivalent weight)



MRG2-25 (NCK-1.2)
MRG2-16 (NCK-0.7)
MRG2-10 (NCK-0.3)

- SCP*2
- CMK2
- CMA2
- SCM
- SCG
- SCA2
- SCS
- CKV2
- CA/OV2
- SSD
- CAT
- MDC2
- MVC
- SMD2
- MSD*
- FC*
- STK
- ULK*
- JSK/M2
- JSG
- JSC3
- USSD
- USC
- JSB3
- LMB
- STG
- STS/L
- LCS
- LCG
- LCM
- LCT
- LCY
- STR2
- UCA2
- HCM
- HCA
- SRL2
- SRG
- SRM
- SRT
- MRL2
- MRG2**
- SM-25
- CAC3
- UCAC
- RCC2
- MFC
- SHC
- GLC

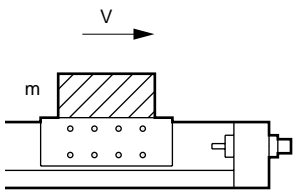
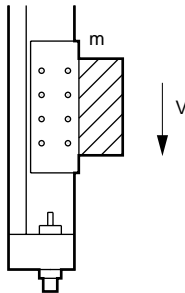
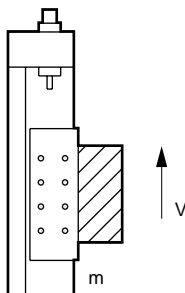
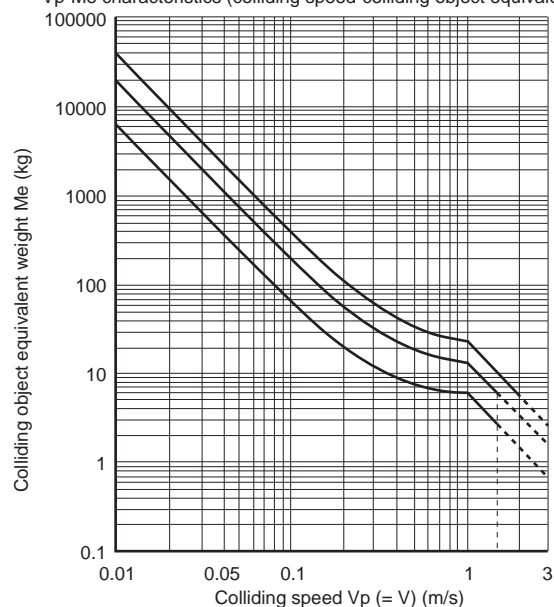
Ending
Magnet rodless cylinder high precision guide types
Rodless type

STEP-8

● Inertia load confirmation

The inertial force generated from the load is applied at the stroke end.
Confirm that the force is within the allowable range.

(1) Calculate inertia force (F_i) according to velocity (V) and inertia force coefficient on Fig.5.

$$F_i = 9.8 \times m \times G \text{ (N)}$$

m: Load weight (kg)

G: Inertia force coefficient

Fig.5. Inertia force coefficient

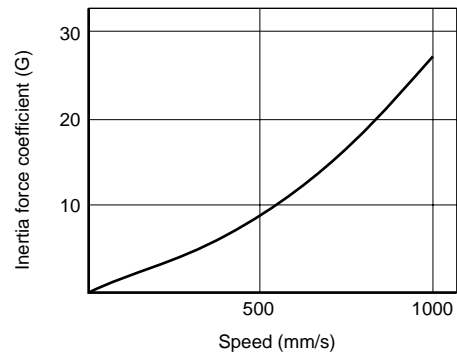

(2) Calculate the load or moment generated from the inertial force.

(Example)

$$M1i = F_i \times \ell_1$$

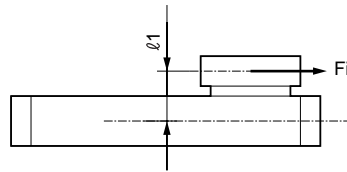

$$W1i = F_i$$

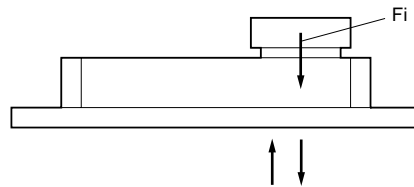

When elevating the entire cylinder

(3) Add the load or moment generated by the static load and inertial force, and divide it by the allowable value given in Table 4. Confirm that the total is 1.0 or less.

$$W1g = W1 + W1i$$

$$M1g = M1 + M1i$$

$$W2g = W2 + W2i$$

$$M2g = M2 + M2i$$

$$M3g = M3 + M3i$$

$$\frac{W1g \text{ (or } W2g)}{W1 \text{ (or } W2) \text{ max.}} + \frac{M1g}{M1 \text{ max}} + \frac{M2g}{M2 \text{ max}} + \frac{M3g}{M3 \text{ max}} \leq 1.0$$

Displacement of MRG2 table (reference value)

- Bending moment direction
 $M1 = F \times L$

- Radial moment direction
 $M2 = F \times L$

- Twist moment direction
 $M3 = F \times L$

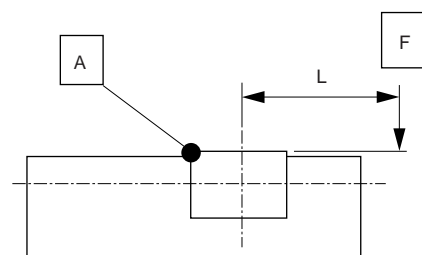
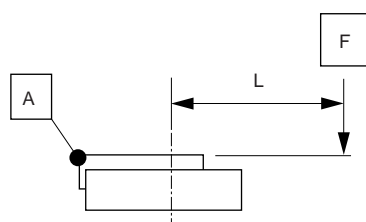
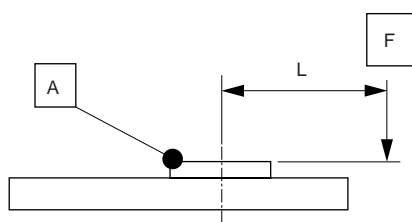

A displacement amount = table displacement amount

- MRG2-10

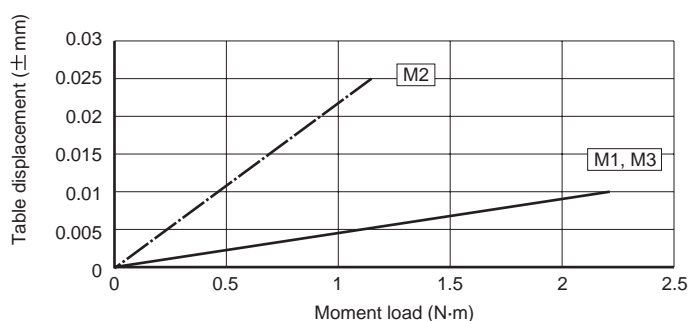

- MRG2-16

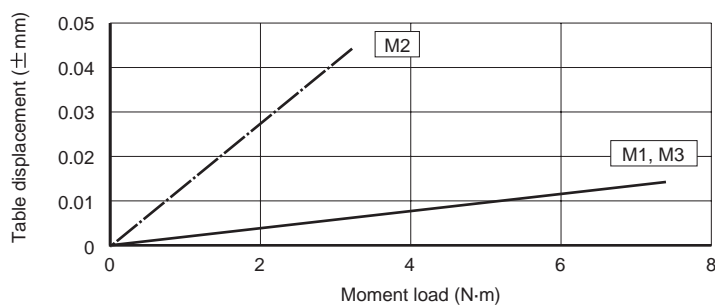

- MRG2-25

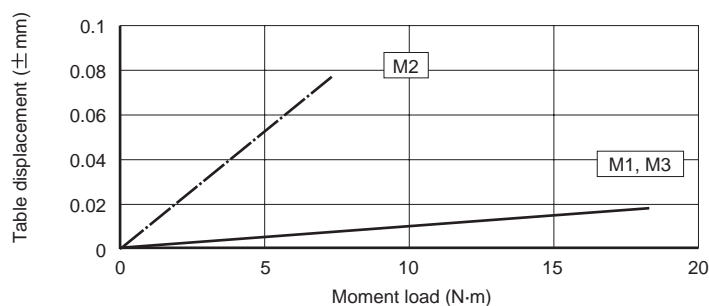

Note: The table displacement amount indicates the reference value at the stroke end.

SCP*2
CMK2
CMA2
SCM
SCG
SCA2
SCS
CKV2
CA/OV2
SSD
CAT
MDC2
MVC
SMD2
MSD*
FC*
STK
ULK*
JSK/M2
JSG
JSC3
USSD
USC
JSB3
LMB
STG
STS/L
LCS
LCG
LCM
LCT
LCY
STR2
UCA2
HCM
HCA
SRL2
SRG
SRM
SRT
MRL2
MRG2
SM-25
CAC3
UCAC
RCC2
MFC
SHC
GLC
Ending

Magnet rodless cylinder high precision guide types
Rodless type