

Series variation

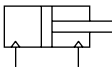
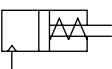
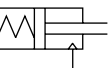
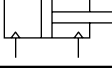

Small direct mounting cylinder MDC2 Series

●: Standard, ◎: Option, ■: Not available

Variation	Model no. JIS symbol	Bore size (mm)	Standard stroke length (mm)					Min. stroke length (mm)	Max. stroke length (mm)	Switch	Page
			3	4	6	8	10				
Double acting single rod type with switch 	MDC2 MDC2-L	φ4	●	■	●	■	■	3	6	◎	966
		φ6	■	●	●	●	■	4	8	◎	
		φ8	■	●	●	●	■		◎		
		φ10	■	●	●	■	●		◎		
Single acting extend type with switch 	MDC2-X MDC2-XL	φ4	●	■	●	■	3	6	■	972	
		φ6	■	●	●	●	■	4	8		◎
		φ8	■	●	●	●	■		◎		
		φ10	■	●	●	■	●		◎		
Single acting retract type with switch 	MDC2-Y MDC2-YL	φ4	●	■	●	■	3	6	■	972	
		φ6	■	●	●	●	■	4	8		◎
		φ8	■	●	●	●	■		◎		
		φ10	■	●	●	■	●		◎		
Double acting fine speed type with switch 	MDC2-F MDC2-LF	φ6	■	●	●	●	■	4	8	◎	982
		φ8	■	●	●	●	■		◎		
		φ10	■	●	●	■	●		◎		

- SCP*2
- CMK2
- CMA2
- SCM
- SCG
- SCA2
- SCS
- CKV2
- CA/OV2
- SSD
- CAT
- MDC2**
- MVC
- SMD2
- MSD*
- FC*
- STK
- ULK*
- JSK/M2
- JSG
- JSC3
- USSD
- USC
- JSB3
- LMB
- STG
- STS/L
- LCS
- LCG
- LCM
- LCT
- LCY
- STR2
- UCA2
- HCM
- HCA
- SRL2
- SRG
- SRM
- SRT
- MRL2
- MRG2
- SM-25
- CAC3
- UCAC
- RCC2
- MFC
- SHC
- GLC
- Ending

Variation/option selection table

- ◎ : Option
- : Available (custom order)
- △ : Available depending on conditions (consult with CKD)
- X : Not available

Code	Code	Code	Variation					Port thread		Option			
		Symbol	None	X	Y	L	F	N	G				
Variation	Double acting basic type	Blank						X	X		○	◎	◎
	Single acting extend type	X			X	◎	X	X	X		○	X	X
	Single acting retract type	Y				◎	X	X	X		○	X	X
	With cylinder switch	L						◎	X	X	○	◎	◎
	Fine speed type	F							X	X	X	◎	◎
Port thread	NPT	N								X	X	X	X
	G	G									X	X	X
Option	Copper and PTFE free type	P6										X	X
	Clean room specifications (exhaust treatment)	P7											X
	Clean room specifications (vacuum treatment)	P71											
Accessory	Cylinder switch	Listed on Ending	◎	◎	◎	◎	◎	X	X		○	◎	◎

Note 1: Refer to the Clean Component System (Catalog No. CB-O33SA) for clean room specifications P7 and P71.

<Example of model number>

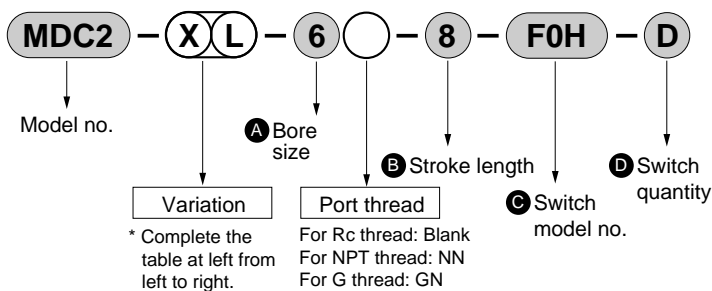

Model no.: Small direct mounting cylinder

- Variation: Single acting extend type with switch
- A Bore size : φ 6mm
- B Stroke length : 8mm
- C Switch model no. : Reed FO switch, lead wire 1m
- D Switch quantity : 2

SCP*2
CMK2
CMA2
SCM
SCG
SCA2
SCS
CKV2
CA/OV2
SSD
CAT
MDC2
MVC
SMD2
MSD*
FC*
STK
ULK*
JSK/M2
JSG
JSC3
USSD
USC
JSB3
LMB
STG
STS/L
LCS
LCG
LCM
LCT
LCY
STR2
UCA2
HCM
HCA
SRL2
SRG
SRM
SRT
MRL2
MRG2
SM-25
CAC3
UCAC
RCC2
MFC
SHC
GLC
Ending

Small direct mounting cylinder
Space saving structure



Safety precautions

Always read this section before starting use.

Refer to Intro 71 for general details on the cylinder, and to Intro 78 for details on the cylinder.

Small direct mounting cylinder MDC2 Series

Design & Selection

1. Common

CAUTION

■ MDC2 with reed switch cannot be installed on magnetic substance (iron plate, etc.).

■ MDC2 with proximity switch should be used at ambient temperature 40°C or less. Failure to observe this may cause switch detection defective.

2. Single acting MDC2-X, Y

CAUTION

■ Do not leave the single acting cylinder in the pressurized state. If left under elevated pressure, the piston rod may not return with the spring force when pressure is released.

3. Fine speed type MDC2-F

CAUTION

■ Use with oil-free specifications.

- Features may change if the device is lubricated.

■ Assemble the flow control valve near the cylinder.

- Adjustments become unstable if assembled away from the cylinder.
- Use the SC-M3/M5, SC3W, SCD-M3/M5, or SC3WU Series speed control valve.

■ Generally, the higher the air pressure, the smaller the load results in the more stable operation.

- Keep the load factor at 50% or less.

■ Stable speed control is achieved with a meter-out circuit.

- When driving the single rod cylinder at fine speed with the operation direction set to PUSH, popping-out may occur if operation is started when load resistance is small. As countermeasures, use a (b), (c), or (d) circuit. Note that the (d) circuit is the most stable.

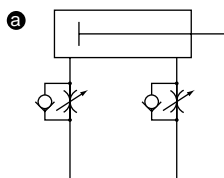

PUSH: meter-out
PULL: meter-out

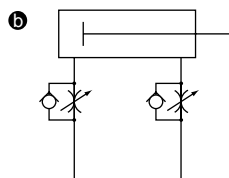

PUSH: meter-in
PULL: meter-in

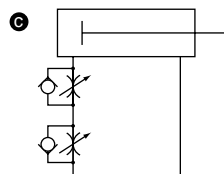

PUSH: meter-in
PULL: meter-out

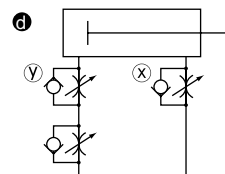

PUSH: meter-in/out
PULL: meter-out

① Speed adjustment method of PUSH operation of circuit:

1. Set the speed with the x flow control valve
2. Lower the flow rate with the y flow control valve until popping out no longer occurs
3. Reconfirm speed

(Note 1) When (b), (c) and (d) are compared, (d) circuit operation is most stable.
(Note 2) When installed vertically, the load will drop naturally if the meter-in circuit is used. Use the meter-out circuit in this case.

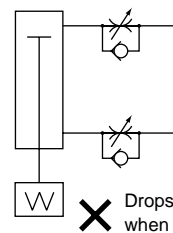
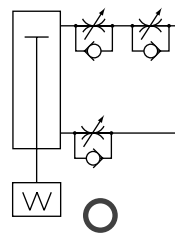

(Note 3) Connect the speed control valve in the parallel with the following circuit:

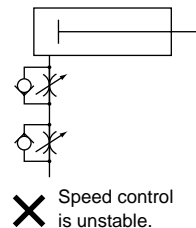
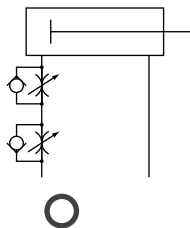

(Popping out phenomenon causes)

- The meter-out circuit slows the flow so fine speed is attained on the exhaust side, so both side reach the same pressure immediately after the valve is changed and the thrust of the piston pressurized area difference functions in the PUSH direction, causing popping out.

(Guide for popping out occurrence)

- Popping out occurs when the piston rod area x air pressure > load resistance.

■ Do not apply lateral load the cylinder.

Install the cylinder so the sliding guide is not twisted.

- Operation may become unstable due to fluctuations in load and resistance.
- Operation of a guide having a large difference in static and dynamic friction may become unstable.

■ Avoid use with vibration.

- The product would be adversely affected by vibration and operation may become unstable.

Installation & Adjustment

1. Common

⚠ CAUTION

■ Applicable piping joints are limited. See the following table when making a selection.

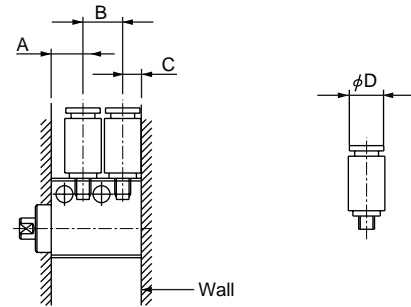

Descriptions Bore(mm)	Port size	Port dimension (mm)				When there is a wall			When there is no wall			
		Stroke length	A	B	C	Applicable joints	Joint outer diameter φD	Incompatible joint	Applicable joints	Joint outer diameter φD	Incompatible joint	
φ4	M3	3	6.5	7	3.5	GWS3-M3-S FTS4-M3	φ7 or less	GWS4-M3-S SC3W-M3-3 SC3W-M3-4 SC3WU-M3-3 SC3WU-M3-4	GWS3-M3-S FTS4-M3	φ7 or less	GWS4-M3-S SC3W-M3-3 SC3W-M3-4 SC3WU-M3-3 SC3WU-M3-4	
		6	6.5	10	3.5				GWS3-M3-S GWS4-M3-S FTS4-M3 SC3W-M3-* SC3WU-M3-*			φ10 or less
φ6	M3	4	6	7.5	3.5	GWS3-M3-S FTS4-M3	φ7 or less	GWS4-M3-S SC3W-M3-3 SC3W-M3-4 SC3WU-M3-3 SC3WU-M3-4	GWS3-M3-S SC3W-M3-* SC3WU-M3-*	φ7.5 or less	GWS4-M3-S	
		6	6	9.5	3.5				GWS3-M3-S GWS4-M3-S FTS4-M3 SC3W-M3-* SC3WU-M3-*			φ9.5 or less
		8	6	11.5	3.5				↑			φ11.5 or less
φ8	M3	4	6	7.5	3.5	GWS3-M3-S FTS4-M3	φ7 or less	GWS4-M3-S SC3W-M3-3 SC3W-M3-4 SC3WU-M3-3 SC3WU-M3-4	GWS3-M3-S SC3W-M3-* SC3WU-M3-*	φ7.5 or less	GWS4-M3-S	
		6	6	9.5	3.5				GWS3-M3-S GWS4-M3-S FTS4-M3 SC3W-M3-* SC3WU-M3-*			φ9.5 or less
		8	6	11.5	3.5				↑			φ11.5 or less
φ10	M5	4	7	10	5	GWS*-M5-S SC3W-M5-* SC3WU-M5-* GWS4-M5-S FTS4-M5 FTS6-M5	φ10 or less	GWS*-M5 GWS6-M5-S	GWS*-M5-S SC3W-M5-* SC3WU-M5-* GWS4-M5-S GWS6-M5-S GWS4-M5 FTS4-M5 FTS6-M5	φ10 or less	GWS*-M5 GWS6-M5-S	
		6	7	12	5				GWS*-M5-S SC3W-M5-* SC3WU-M5-* GWS4-M5-S GWS6-M5-S GWS4-M5 FTS4-M5 FTS6-M5			φ12 or less
		10	7	16	5				GWS*-M5-S SC3W-M5-* SC3WU-M5-* GWS4-M5-S GWS6-M5-S GWS4-M5 GWS6-M5 FTS4-M5 FTS6-M5			φ14 or less

*Port position dimensions are for when no switch is used.

2. Fine speed type MDC2-F

⚠ CAUTION

■ Align the centers, etc., so that no lateral load is applied to the cylinder.

Install the cylinder so the sliding guide is not twisted.

- Operation may become unstable due to fluctuations in load and resistance.
- Operation of a guide having a large difference in static and dynamic friction may become unstable.

SCP*2
CMK2
CMA2
SCM
SCG
SCA2
SCS
CKV2
CA/OV2
SSD
CAT
MDC2
MVC
SMD2
MSD*
FC*
STK
ULK*
JSK/M2
JSG
JSC3
USSD
USC
JSB3
LMB
STG
STS/L
LCS
LCG
LCM
LCT
LCY
STR2
UCA2
HCM
HCA
SRL2
SRG
SRM
SRT
MRL2
MRG2
SM-25
CAC3
UCAC
RCC2
MFC
SHC
GLC
Ending

Small direct mounting cylinder
Space saving structure

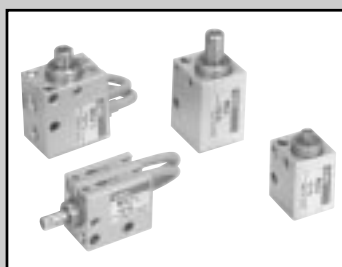

Small direct mounting cylinder, double acting single rod type

MDC2 Series

● Bore size: $\phi 4$, $\phi 6$, $\phi 8$, $\phi 10$

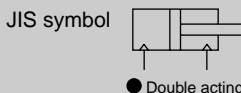

Specifications

Descriptions	MDC2/MDC2-L (with switch)			
Bore size mm	$\phi 4$ Note 1	$\phi 6$	$\phi 8$	$\phi 10$
Actuation	Double acting			
Working fluid	Compressed air			
Max. working pressure MPa	0.7			
Min. working pressure MPa	0.2	0.15	0.1	
Withstanding pressure MPa	1.05			
Ambient temperature $^{\circ}\text{C}$	-10 to 60 (no freezing) Note 2			
Port size	M3			M5
Stroke tolerance mm	+0.5			
	0			
Working piston speed mm/s	50 to 500			
Cushion	None			
Lubrication	Not required (when lubricating, use turbine oil Class 1 ISO VG32.)			
Allowable energy absorption J	A cylinder without cushion cannot absorb an energy generated by an external load. Use this with leadless or install an external shock absorber.			

Note 1: $\phi 4$ is not available for MDC2-L.

Note 2: When proximity switch is installed, use the product at 40 $^{\circ}\text{C}$ or less.

Stroke length

Bore size (mm)	Standard stroke length (mm)	Max. stroke length (mm)	Min. stroke length with 2 switches (mm)		Min. stroke length with 1 switch (mm)	
			Reed switch	Proximity switch	Reed switch	Proximity switch
$\phi 4$	3, 6	6	-	-	-	-
$\phi 6$	4, 6, 8	8	6	4	4	4
$\phi 8$	4, 6, 8	8	8	4	4	4
$\phi 10$	4, 6, 10	10	6	4	4	4

Note: Other than standard stroke length is not available.

Cylinder switch specifications

Descriptions	Reed 2 wire	Proximity 2 wire	Proximity 3 wire
	F0H/V	F2H/V	F3H/V
Applications	Programmable controller		Programmable controller, relay
Output method	-		NPN output
Power voltage	-	-	10 to 28 VDC
Load voltage	24 VDC	10 to 30 VDC	30 VDC or less
Load current	5 to 20mA (Note 1)	5 to 20mA (Note 1)	50mA or less
Current consumption	-	-	10mA or less (at ON state) at 24 VDC
Internal voltage drop	4 V or less		0.5 V or less
Light	Yellow LED (ON lighting)		
Leakage current	1mA or less		10 μA or less
Lead wire length (standard)	Standard 1m (oil resistant vinyl cabtire cord 2 conductor 0.15mm ²)		Standard 1m (oil resistant vinyl cabtire cord 3 conductor 0.15mm ²)
Maximum shock resistance	294m/s ²	980m/s ²	
Insulation resistance	20M Ω and over at 500 VDC megger		
Withstand voltage	No failure at 1000 VAC for one minute.		
Ambient temperature	-10 to + 60 $^{\circ}\text{C}$		
Protective structure	IEC standards IP67, JIS C 0920 (water tight type), oil resistance		

Note 1: Max. load current 20mA is the value at 25 $^{\circ}\text{C}$.

When ambient temperature around switch is higher than 25 $^{\circ}\text{C}$, the value is lower than 20mA. (5 to 10mA at 60 $^{\circ}\text{C}$)

Clean room specifications (Catalog No. CB-033SA)

- Dust generation preventing structure for use in clean room

MDC2 P7*

MDC2 P5*

Cylinder weight

Stroke length (mm)	3		4		6		8		10		Weight per 1 switch (g)
	W/o switch	With switch	W/o switch	With switch	W/o switch	With switch	W/o switch	With switch	W/o switch	With switch	
φ4	6.4	-	-	-	7.3	-	-	-	-	-	-
φ6	-	-	11.4	13.1	12.4	14	13.4	15	-	-	10
φ8	-	-	16.1	18.2	17.4	19.5	18.7	20.8	-	-	10
φ10	-	-	21.4	23.3	22.6	24.5	-	-	25	26.9	10

How to order

- Without switch

MDC2 - 6 - 4

- With switch

MDC2-L - 6 - 4 - F2V - R

A Model no.

B Bore size

C Stroke length

D Switch model no. Note 1
Note 2
Note 3
Note 4

E Switch quantity

Note on model no. selection

- Note 1: For φ 4 cylinder, switches are not available.
 Note 2: Min. stroke length with two reed switches is 6mm for φ 6, 8mm for φ 8 and 6mm for φ 10.
 Note 3: MDC2 with reed switch cannot be installed on magnetic substance (iron plate, etc.). Failure to observe this may cause switch detection defective.
 Note 4: For MDC2-L-6 with reed switch, use mounting bolts that do not contain magnetic substance (stainless steel hexagon socket head cap screw etc.). Failure to observe this may cause switch detection defective.

<Example of model number>

MDC2-L-6-4-F2V-R

Model: Small direct mounting cylinder

- A Model no. : Double acting single rod type with switch
- B Bore size : φ 6mm
- C Stroke length : 6mm
- D Switch model no. : Proximity switch F2V, lead wire 1m
- E Switch quantity : 1 on rod end

Symbol	Descriptions			
A Model no.				
MDC2	Double acting, single rod type	Without switch		
MDC2-L	Double acting, single rod type	With switch		
B Bore size				
4	φ4			
6	φ6			
8	φ8			
10	φ10			
C Stroke length (mm)				
3	3 (φ 4)			
4	4 (φ 6 to φ 10)			
6	6 (φ 4 to φ 10)			
8	8 (φ 6, φ 8)			
10	10 (φ 10)			
D Switch model no.				
Axial lead wire	Radial lead wire	Contact	Indicator	Lead wire
F0H*	F0V*	Reed	1 color indicator type	2-wire
F2H*	F2V*	Proximity		3-wire
F3H*	F3V*			
*Lead wire length				
Blank	1m (standard)			
3	3m (option)			
E Switch quantity				
R	1 on rod end			
H	1 on head end			
D	Two			

How to order switch

SW - F0H

Switch model no. (Item D above)

SCP*2
CMK2
CMA2
SCM
SCG
SCA2
SCS
CKV2
CA/OV2
SSD
CAT
MDC2
MVC
SMD2
MSD*
FC*
STK
ULK*
JSK/M2
JSG
JSC3
USSD
USC
JSB3
LMB
STG
STS/L
LCS
LCG
LCM
LCT
LCY
STR2
UCA2
HCM
HCA
SRL2
SRG
SRM
SRT
MRL2
MRG2
SM-25
CAC3
UCAC
RCC2
MFC
SHC
GLC
Ending

Small direct mounting cylinder
Space saving structure

Internal structure and parts list

SCP*2
CMK2
CMA2
SCM
SCG
SCA2
SCS
CKV2
CA/OV2
SSD
CAT
MDC2
MVC
SMD2
MSD*
FC*
STK
ULK*
JSK/M2
JSG
JSC3
USSD
USC
JSB3
LMB
STG
STS/L
LCS
LCG
LCM
LCT
LCY
STR2
UCA2
HCM
HCA
SRL2
SRG
SRM
SRT
MRL2
MRG2
SM-25
CAC3
UCAC
RCC2
MFC
SHC
GLC
Ending

● MDC2-4 (double acting single rod type)

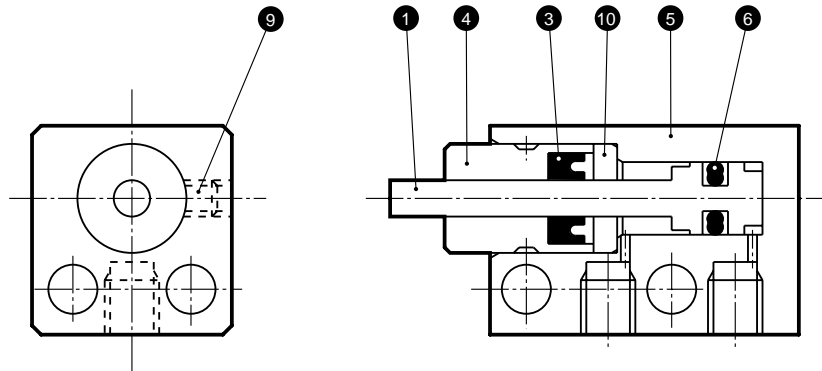

● MDC2-L-6, 8, 10 (double acting single rod type/with switch)

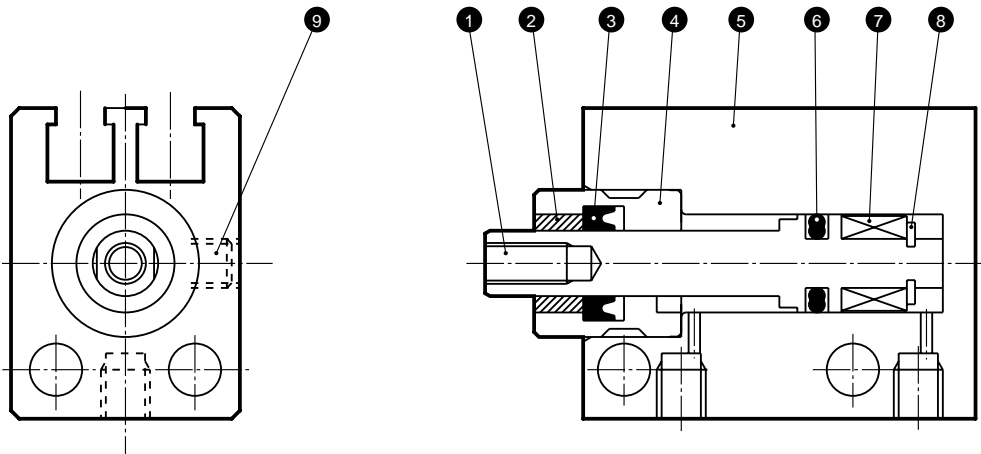

● MDC2-6, 8, 10 (double acting single rod type)

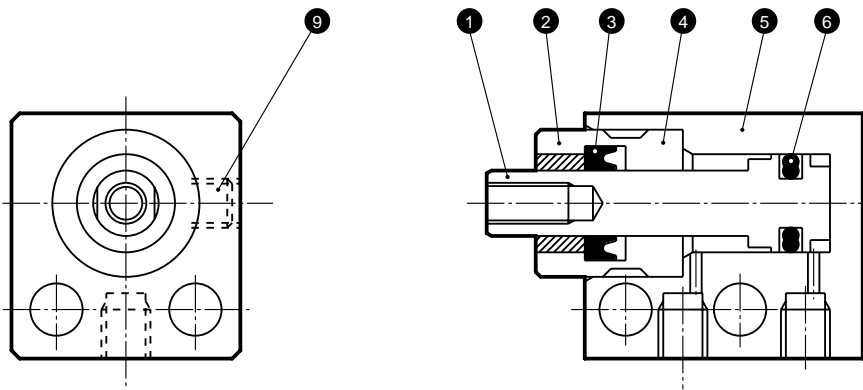

No.	Parts name	Material	Remarks	No.	Parts name	Material	Remarks
1	Piston	Stainless steel		6	Piston packing seal	Nitrile rubber	
2	Bush	Oil impregnated copper alloy		7	Magnet	Plastic	
3	Rod packing seal	Nitrile rubber		8	E type snap ring	Stainless steel	
4	Rod bushing	ϕ 4: phosphor bronze ϕ 6 to ϕ 10: stainless steel		9	Hexagon socket head set screw	Stainless steel	
5	Body	Aluminum alloy	Hard alumite	10	Collar	Stainless steel	

Dimensions



- MDC2-4-3, 6 (single acting retract/with switch)

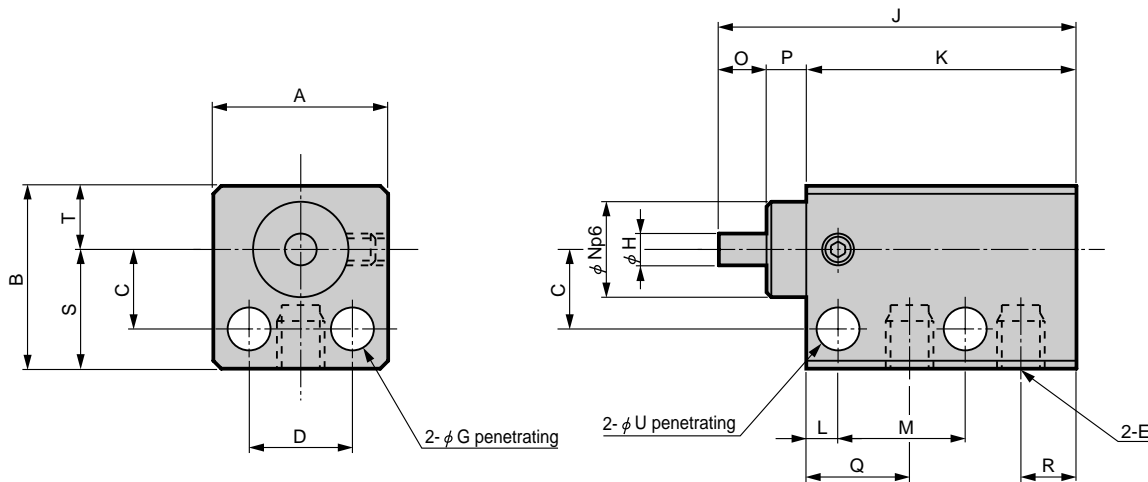

Model no.	A	B	C	D	E	G	H	J	K	L	M	N	O	P	Q	R	S	T	U
MDC2-4-3	11	11.5	5	6.5	M3	2.7	2	22.5	17	2	8	6	3	2.5	6.5	3.5	7.5	4	2.7
MDC2-4-6	11	11.5	5	6.5	M3	2.7	2	25.5	20	2	11	6	3	2.5	6.5	3.5	7.5	4	2.7

SCP*2
CMK2
CMA2
SCM
SCG
SCA2
SCS
CKV2
CA/OV2
SSD
CAT
MDC2
MVC
SMD2
MSD*
FC*
STK
ULK*
JSK/M2
JSG
JSC3
USSD
USC
JSB3
LMB
STG
STS/L
LCS
LCG
LCM
LCT
LCY
STR2
UCA2
HCM
HCA
SRL2
SRG
SRM
SRT
MRL2
MRG2
SM-25
CAC3
UCAC
RCC2
MFC
SHC
GLC
Ending

Small direct mounting cylinder
Space saving structure

Dimensions



● MDC2-6, 8, 10 (double acting single rod/without switch)

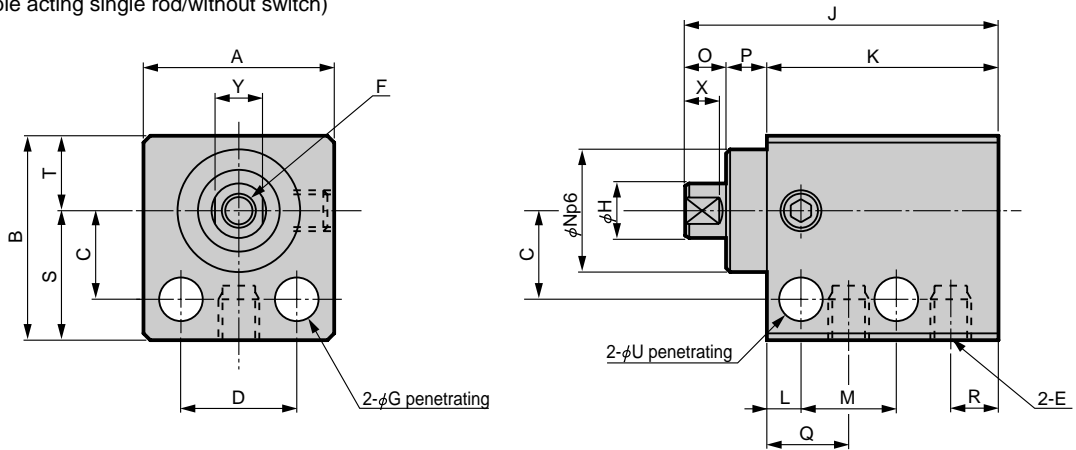

Model no.	Stroke length	A	B	C	D	E	F	G	H	J	K	L	M	O	N	P	Q	R	S	T	U	X	Y
MDC2-6	4	14	15	6.5	8.5	M3	M2.5 x	3.2	4	23	17	2.5	7.5	3	9	3	6	3.5	9.5	5.5	3.2	2.5	3.5
	0.45						25			19	9												
	depth 4						27			21	11												
MDC2-8	4	16	17	7.5	10	M3	M3 x	3.2	5	23	17	2.5	7.5	3	11	3	6	3.5	10.5	6.5	3.2	2.5	4.5
	0.5						25			19	9												
	depth 5						27			21	11												
MDC2-10	4	16	17.5	8	10	M5	M3 x	3.2	6	28	22	2.5	9.5	3	11	3	7	5	11	6.5	3.2	2.5	5
	0.5						30			24	11.5												
	depth 5						34			28	15.5												

● MDC2-L-6, 8, 10 (double acting single rod/with switch)

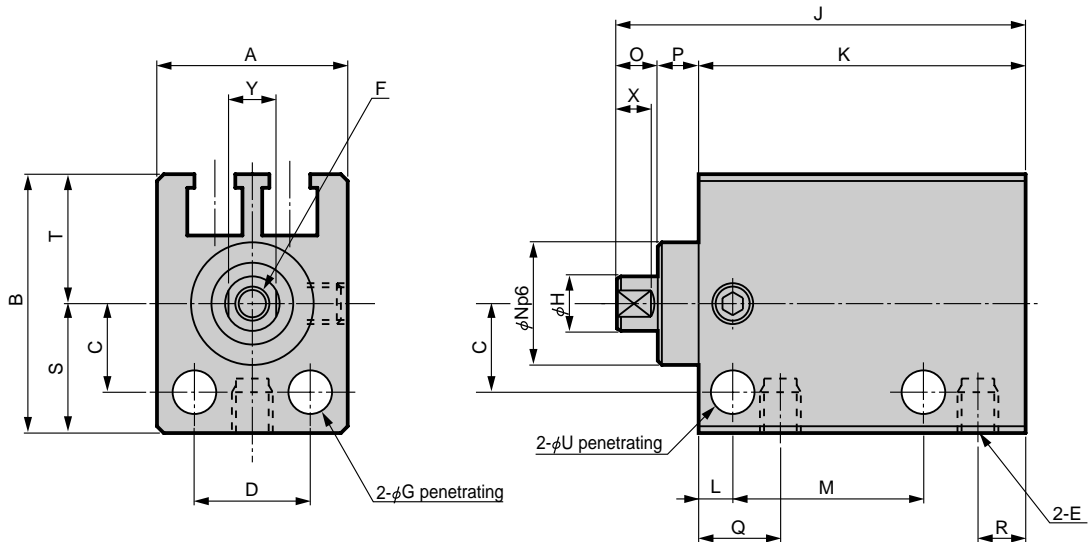

Model no.	Stroke length	A	B	C	D	E	F	G	H	J	K	L	M	O	N	P	Q	R	S	T	U	X	Y
MDC2-L-6	4	14	19	6.5	8.5	M3	M2.5 x	3.2	4	28	22	2.5	12.5	3	9	3	6	3.5	9.5	9.5	3.2	2.5	3.5
	0.45						30			24	14												
	depth 4						32			26	16												
MDC2-L-8	4	16	22	7.5	10	M3	M3 x	3.2	5	28	22	2.5	12.5	3	11	3	6	3.5	11	11	3.2	2.5	4.5
	0.5						30			24	14												
	depth 5						32			26	16												
MDC2-L-10	4	16	22	8	10	M5	M3 x	3.2	6	31	25	2.5	12.5	3	11	3	7	5	11	11	3.2	2.5	5
	0.5						33			27	14.5												
	depth 5						37			31	18.5												



Small direct mounting cylinder, single acting extend, single acting retract types

MDC2-X_Y Series

● Bore size: $\phi 4$, $\phi 6$, $\phi 8$, $\phi 10$

JIS symbol

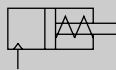

● Single acting extend type

● Single acting return type



Specifications

Descriptions		MDC2-X, MDC2-Y, MDC2-XL(with switch), MDC2-YL(with switch)			
Bore size	mm	$\phi 4$ Note 1	$\phi 6$	$\phi 8$	$\phi 10$
Actuation	MDC2-X (L)	Single acting extend type			
	MDC2-Y (L)	Single acting retract type			
Working fluid		Compressed air			
Max. working pressure	MPa	0.7			
Min. working pressure	MDC2-X (L)	0.35	0.3		0.25
	MDC2-Y (L)	0.4	0.3		0.25
Withstanding pressure	MPa	1.05			
Ambient temperature	°C	-10 to 60 (no freezing) Note 2			
Port size		M3			M5
Stroke tolerance	mm	+0.5			
		0			
Working piston speed	mm/s	50 to 500			
Cushion		None			
Lubrication		Not required (when lubricating, use turbine oil Class 1 ISO VG32.)			
Allowable energy absorption	J	A cylinder without cushion cannot absorb an energy generated by an external load. Use this with leadless or install an external shock absorber.			

Note 1: $\phi 4$ is not available for MDC2-XL, MDC2-YL or MDC2-YL.

Note 2: When proximity switch is installed, use the product at 40°C or less.

Stroke length

Bore size (mm)	Standard stroke length (mm)	Max. stroke length (mm)	Min. stroke length with 2 switches (mm)		Min. stroke length with 1 switch (mm)	
			Reed switch	Proximity switch	Reed switch	Proximity switch
$\phi 4$	3, 6	6	-	-	-	-
$\phi 6$	4, 6, 8	8	6	4	4	4
$\phi 8$	4, 6, 8	8	8	4	4	4
$\phi 10$	4, 6, 10	10	6	4	4	4

Note: Other than standard stroke length is not available.

Cylinder switch specifications

Descriptions	Reed 2 wire	Proximity 2 wire	Proximity 3 wire
	F0H/V	F2H/V	F3H/V
Applications	Programmable controller		Programmable controller, relay
Output method	-		NPN output
Power voltage	-	-	10 to 28 VDC
Load voltage	24 VDC	10 to 30 VDC	30 VDC or less
Load current	5 to 20mA (Note 1)	5 to 20mA (Note 1)	50mA or less
Current consumption	-	-	10mA or less (at ON state) at 24VDC
Internal voltage drop	4V or less		0.5V or less
Light	Yellow LED (ON lighting)		
Leakage current	1mA or less		10 μ A or less
Lead wire length (standard)	Standard 1m (oil resistant vinyl cabtire cord 2 conductor 0.15mm ²)		Standard 1m (oil resistant vinyl cabtire cord 3 conductor 0.15mm ²)
Maximum shock resistance	294m/s ²	980m/s ²	
Insulation resistance	20M Ω and over at 500 VDC megger		
Withstand voltage	No failure at 1000 VAC for one minute.		
Ambient temperature	-10 to +60°C		
Protective structure	IEC standards IP67, JIS C 0920 (water tight type), oil resistance		

Note 1: Max. load current 20mA is the value at 25°C.

When ambient temperature around switch is higher than 25°C, the value is lower than 20mA. (5 to 10mA at 60°C)

Cylinder weight table

Stroke length (mm)		3		4		6		8		10		Weight per 1 switch (g)
Bore size (mm)	Model no.	W/o switch	With switch	W/o switch	With switch	W/o switch	With switch	W/o switch	With switch	W/o switch	With switch	
φ4	MDC2-X	4.9	-	-	-	6.9	-	-	-	-	-	-
	MDC2-Y	7.4	-	-	-	9.4	-	-	-	-	-	
φ6	MDC2-X	-	-	10.9	12.6	11.2	14.4	15.1	16.8	-	-	10
	MDC2-Y	-	-	13.3	15	15	16.7	17.5	19.2	-	-	
φ8	MDC2-X	-	-	16	18	18.4	20.5	20.7	22.8	-	-	10
	MDC2-Y	-	-	19	21	21.4	23.5	23.7	25.8	-	-	
φ10	MDC2-X	-	-	19.6	22	22	24.4	-	-	26.9	29.3	10
	MDC2-Y	-	-	21.2	23.4	23.6	25.8	-	-	28.5	30.7	

MDC2-X/MDC2-Y spring load

Bore size (mm)	Stroke length (mm)	Spring load (N)	
		When set	Operation
φ4	3, 6	1.8	2.9
φ6	4, 6, 8	2.3	5.0
φ8	4, 6, 8	4.0	7.0
φ10	4, 6, 10	4.1	7.4

How to order

● Without switch

MDC2-X - **6** - **4**

● With switch

MDC2-XL - **6** - **4** - **F2V** - **R**

A Model no.

B Bore size

C Stroke length

D Switch model no. Note 1
Note 2
Note 3
Note 4

E Switch quantity

Note on model no. selection

Note 1: For φ 4 cylinder, switches are not available.

Note 2: Min. stroke length with two reed switches is 6mm for φ 6, 8mm for φ 8 and 6mm for φ 10.

Note 3: MDC2 with reed switch cannot be installed on magnetic substance (iron plate, etc.). Failure to observe this may cause switch detection defective.

Note 4: For MDC2-XL, YL-6 with reed switch, use mounting bolts that do not contain magnetic substance (stainless steel hexagon socket head cap screw etc.). Failure to observe this may cause switch detection defective.

<Example of model number>

MDC2-XL-6-4-F2V-R

Model: Small direct mounting cylinder

A Model no. : Single acting extend type with switch

B Bore size : φ 6mm

C Stroke length : 6mm

D Switch model no. : Proximity switch F2V, lead wire 1m

E Switch quantity : 1 on rod end

Symbol	Descriptions			
A Model no.				
MDC2-X	Single acting, extend type	Without switch		
MDC2-Y	Single acting, retract type			
MDC2-XL	Single acting, extend type	With switch		
MDC2-YL	Single acting, retract type			
B Bore size				
4	φ4			
6	φ6			
8	φ8			
10	φ10			
C Stroke length (mm)				
3	3 (φ 4)			
4	4 (φ 6 to φ 10)			
6	6 (φ 4 to φ 10)			
8	8 (φ 6, φ 8)			
10	10 (φ 10)			
D Switch model no.				
Axial lead wire	Radial lead wire	Contact	Indicator	Lead wire
F0H*	F0V*	Reed	1 color indicator type	2-wire
F2H*	F2V*	Proximity		3-wire
F3H*	F3V*			
*Lead wire length				
Blank	1m (standard)			
3	3m (option)			
E Switch quantity				
R	1 on rod end			
H	1 on head end			
D	Two			

How to order switch

SW - **F0H**

Switch model no.
(Item D above)

SCP*2
CMK2
CMA2
SCM
SCG
SCA2
SCS
CKV2
CA/OV2
SSD
CAT
MDC2
MVC
SMD2
MSD*
FC*
STK
ULK*
JSK/M2
JSG
JSC3
USSD
USC
JSB3
LMB
STG
STS/L
LCS
LCG
LCM
LCT
LCY
STR2
UCA2
HCM
HCA
SRL2
SRG
SRM
SRT
MRL2
MRG2
SM-25
CAC3
UCAC
RCC2
MFC
SHC
GLC
Ending

Small direct mounting cylinder
Space saving structure

Internal structure and parts list

● MDC2-X-4 (single acting extend type)

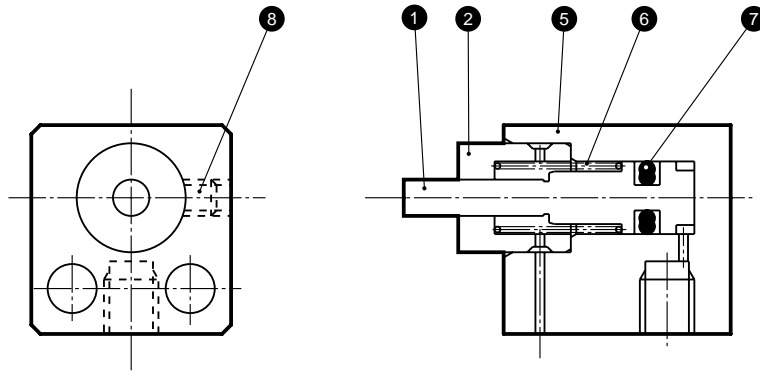

● MDC2-Y-4 (single acting retract type)

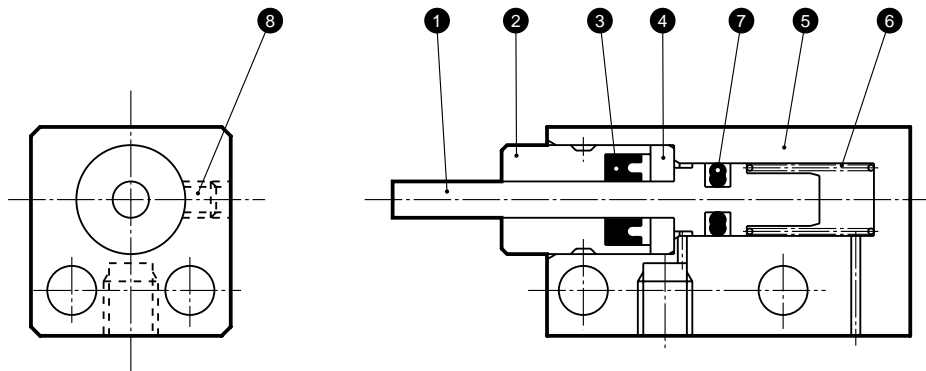

No.	Parts name	Material	Remarks	No.	Parts name	Material	Remarks
1	Piston	Stainless steel		5	Body	Aluminum alloy	Hard alumite
2	Rod bushing	Phosphor bronze		6	Coil spring	Steel	Electrode position coating
3	Rod packing seal	Nitrile rubber		7	Piston packing seal	Nitrile rubber	
4	Collar	Stainless steel		8	Hexagon socket head set screw	Stainless steel	

SCP*2
CMK2
CMA2
SCM
SCG
SCA2
SCS
CKV2
CA/OV2
SSD
CAT
MDC2
MVC
SMD2
MSD*
FC*
STK
ULK*
JSK/M2
JSG
JSC3
USSD
USC
JSB3
LMB
STG
STS/L
LCS
LCG
LCM
LCT
LCY
STR2
UCA2
HCM
HCA
SRL2
SRG
SRM
SRT
MRL2
MRG2
SM-25
CAC3
UCAC
RCC2
MFC
SHC
GLC
Ending

Internal structure and parts list

- MDC2-XL-6, 8, 10 (single acting extend type/with switch)

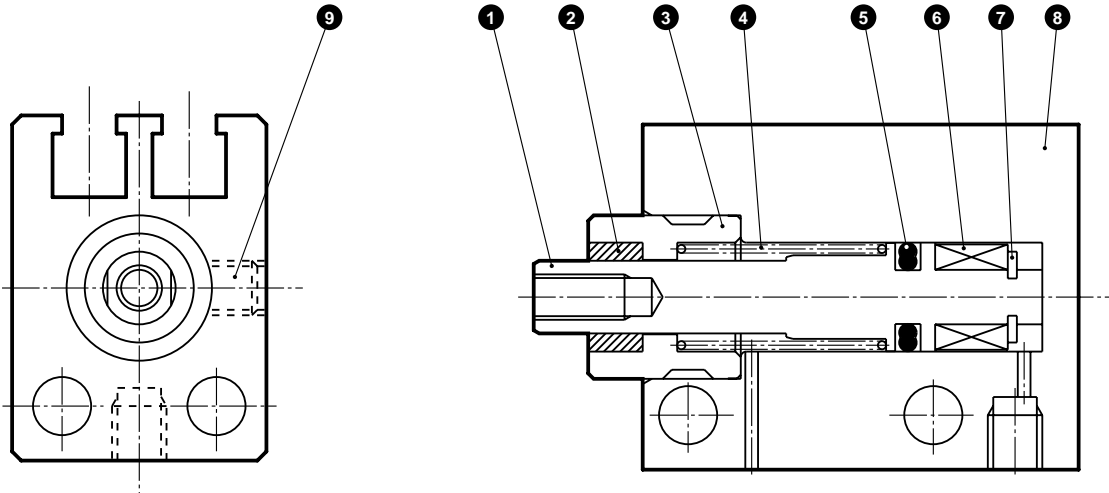

- MDC2-X-6, 8, 10 (single acting extend type)

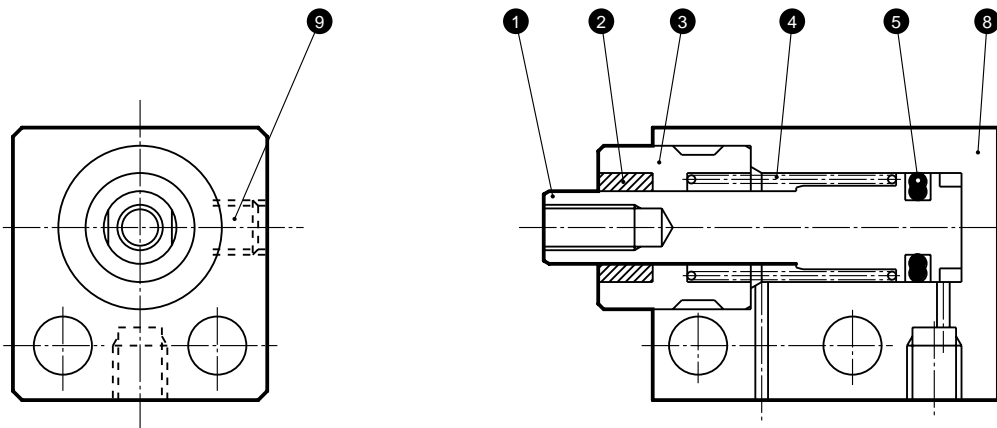

SCP*2
CMK2
CMA2
SCM
SCG
SCA2
SCS
CKV2
CA/OV2
SSD
CAT
MDC2
MVC
SMD2
MSD*
FC*
STK
ULK*
JSK/M2
JSG
JSC3
USSD
USC
JSB3
LMB
STG
STS/L
LCS
LCG
LCM
LCT
LCY
STR2
UCA2
HCM
HCA
SRL2
SRG
SRM
SRT
MRL2
MRG2
SM-25
CAC3
UCAC
RCC2
MFC
SHC
GLC
Ending

No.	Parts name	Material	Remarks	No.	Parts name	Material	Remarks
1	Piston	Stainless steel		6	Magnet	Plastic	
2	Bush	Oil impregnated copper alloy		7	E type snap ring	Stainless steel	
3	Rod bushing	Stainless steel		8	Body	Aluminum alloy	Hard alumite
4	Coil spring	Steel	Electrode position coating	9	Hexagon socket head set screw	Stainless steel	
5	Piston packing seal	Nitrile rubber					

Small direct mounting cylinder
Space saving structure

MDC2-Y Series

Internal structure and parts list

SCP*2
CMK2
CMA2
SCM
SCG
SCA2
SCS
CKV2
CA/OV2
SSD
CAT
MDC2
MVC
SMD2
MSD*
FC*
STK
ULK*
JSK/M2
JSG
JSC3
USSD
USC
JSB3
LMB
STG
STS/L
LCS
LCG
LCM
LCT
LCY
STR2
UCA2
HCM
HCA
SRL2
SRG
SRM
SRT
MRL2
MRG2
SM-25
CAC3
UCAC
RCC2
MFC
SHC
GLC
Ending

● MDC2-YL-6, 8, 10 (single acting/retract type/with switch)

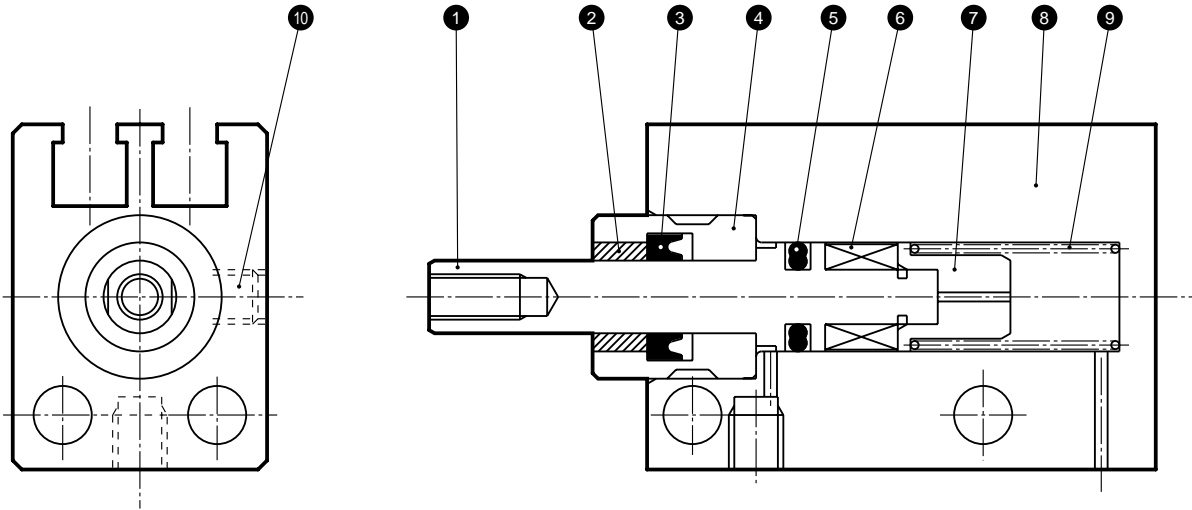

● MDC2-Y-6, 8, 10 (single acting/retract type)

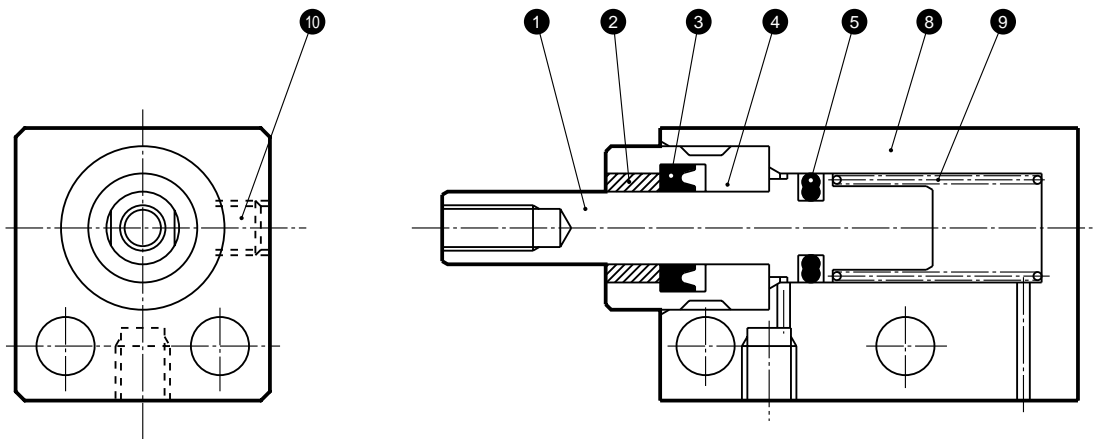

No.	Parts name	Material	Remarks	No.	Parts name	Material	Remarks
1	Piston	Stainless steel		6	Magnet	Plastic	
2	Bush	Oil impregnated copper alloy		7	Spring holder	Stainless steel	
3	Rod packing seal	Nitrile rubber		8	Body	Aluminum alloy	Hard alumite
4	Rod bushing	Stainless steel		9	Coil spring	Steel	Electrodeposition coating
5	Piston packing seal	Nitrile rubber		10	Hexagon socket head set screw	Stainless steel	

Dimensions



SCP*2
CMK2
CMA2
SCM
SCG
SCA2
SCS
CKV2
CA/OV2
SSD
CAT
MDC2
MVC
SMD2
MSD*
FC*
STK
ULK*
JSK/M2
JSG
JSC3
USSD
USC
JSB3
LMB
STG
STS/L
LCS
LCG
LCM
LCT
LCY
STR2
UCA2
HCM
HCA
SRL2
SRG
SRM
SRT
MRL2
MRG2
SM-25
CAC3
UCAC
RCC2
MFC
SHC
GLC
Ending

● MDC2-X-4-3 (single acting extend type)

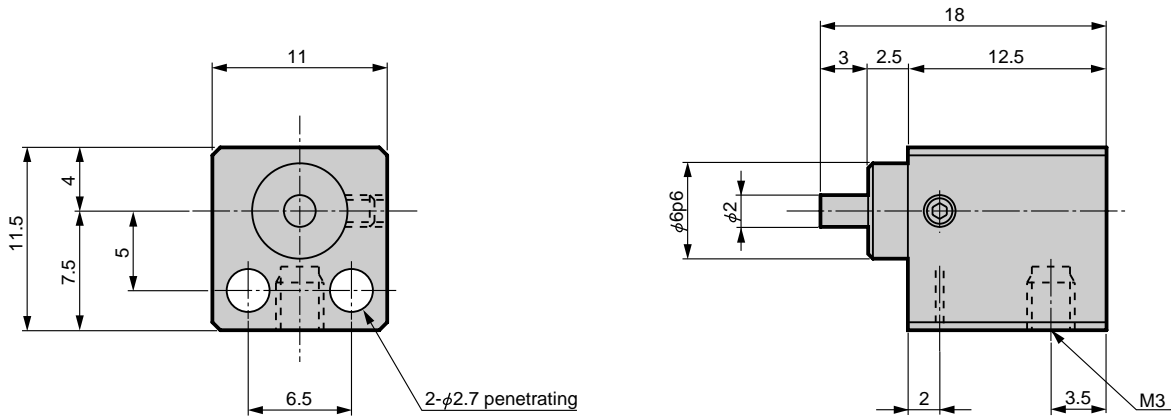

● MDC2-X-4-6 (single acting extend type)

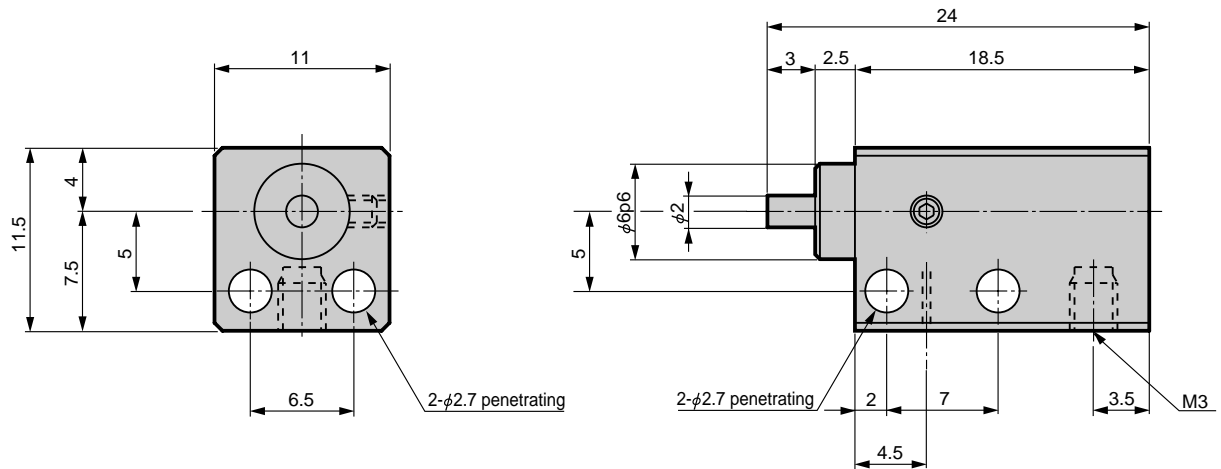

Dimensions



- MDC2-X-6, 8, 10 (single acting extend type/without switch)

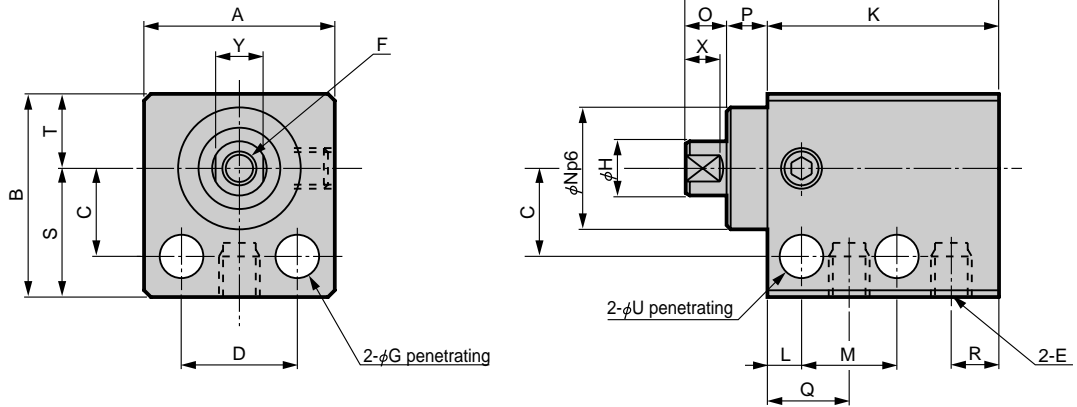

Model no.	Stroke length	A	B	C	D	E	F	G	H	J	K	L	M	O	N	P	Q	R	S	T	U	X	Y
MDC2-X-6	4	14	15	6.5	8.5	M3	M2.5 x	3.2	4	22	16	2.5	6.5	3	9	3	6	3.5	9.5	5.5	3.2	2.5	3.5
	0.45						25			19	8.5												
	depth 4						29			23	10.5												
MDC2-X-8	4	16	17	7.5	10	M3	M3 x	3.2	5	23	17	2.5	7.5	3	11	3	6	3.5	10.5	6.5	3.2	2.5	4.5
	0.5						26			20	9												
	depth 5						29			23	11												
MDC2-X-10	4	16	17.5	8	10	M5	M3 x	3.2	6	26	20	2.5	7.5	3	11	3	7	5	11	6.5	3.2	2.5	5
	0.5						29			23	9.5												
	depth 5						35			29	13.5												

- MDC2-XL-6, 8, 10 (single acting extend type/with switch)

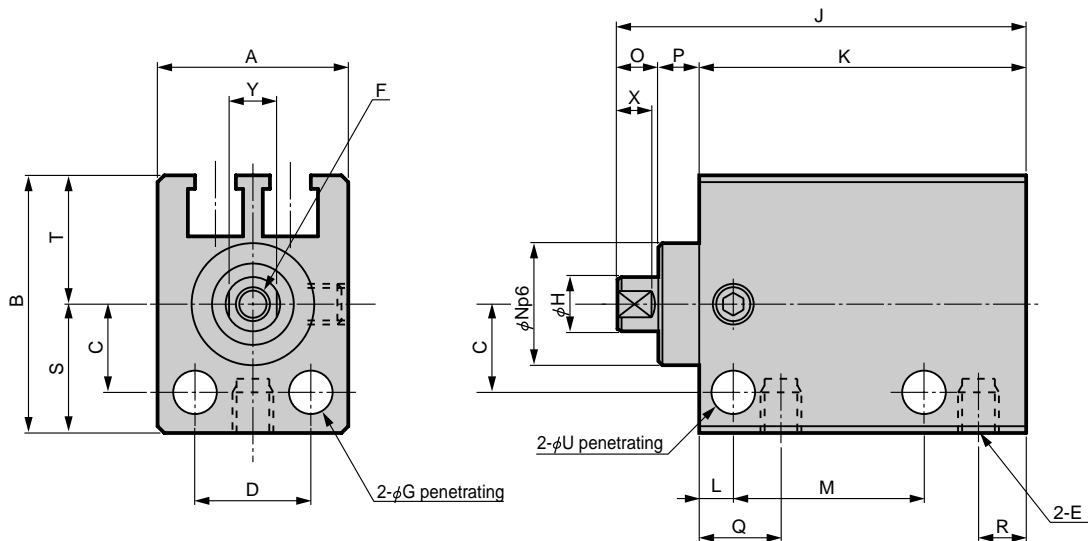

Model no.	Stroke length	A	B	C	D	E	F	G	H	J	K	L	M	O	N	P	Q	R	S	T	U	X	Y
MDC2-XL-6	4	14	19	6.5	8.5	M3	M2.5 x	3.2	4	27	21	2.5	11.5	3	9	3	6	3.5	9.5	9.5	3.2	2.5	3.5
	0.45						30			24	13.5												
	depth 4						34			28	15.5												
MDC2-XL-8	4	16	22	7.5	10	M3	M3 x	3.2	5	28	22	2.5	12.5	3	11	3	6	3.5	11	11	3.2	2.5	4.5
	0.5						31			25	14												
	depth 5						34			28	16												
MDC2-XL-10	4	16	22	8	10	M5	M3 x	3.2	6	31	25	2.5	12.5	3	11	3	7	5	11	11	3.2	2.5	5
	0.5						34			28	14.5												
	depth 5						40			34	18.5												

- SCP*2
- CMK2
- CMA2
- SCM
- SCG
- SCA2
- SCS
- CKV2
- CA/OV2
- SSD
- CAT
- MDC2**
- MVC
- SMD2
- MSD*
- FC*
- STK
- ULK*
- JSK/M2
- JSG
- JSC3
- USSD
- USC
- JSB3
- LMB
- STG
- STS/L
- LCS
- LCG
- LCM
- LCT
- LCY
- STR2
- UCA2
- HCM
- HCA
- SRL2
- SRG
- SRM
- SRT
- MRL2
- MRG2
- SM-25
- CAC3
- UCAC
- RCC2
- MFC
- SHC
- GLC
- Ending

Small direct mounting cylinder
Space saving structure

MDC2-Y Series

Dimensions



- MDC2-Y-4-3, 6 (single acting retract type)

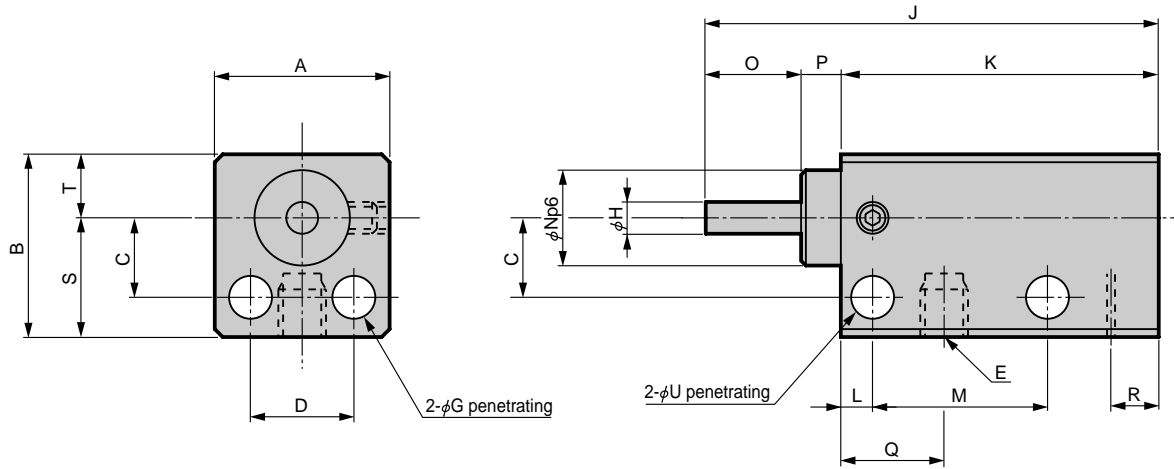

Model no.	A	B	C	D	E	G	H	J	K	L	M	N	O	P	Q	R	S	T	U
MDC2-Y-4-3	11	11.5	5	6.5	M3	2.7	2	28.5	20	2	11	6	6	2.5	6.5	3.5	7.5	4	2.7
MDC2-Y-4-6	11	11.5	5	6.5	M3	2.7	2	37.5	26	2	14	6	9	2.5	6.5	3.5	7.5	4	2.7

- SCP*2
- CMK2
- CMA2
- SCM
- SCG
- SCA2
- SCS
- CKV2
- CA/OV2
- SSD
- CAT
- MDC2**
- MVC
- SMD2
- MSD*
- FC*
- STK
- ULK*
- JSK/M2
- JSG
- JSC3
- USSD
- USC
- JSB3
- LMB
- STG
- STS/L
- LCS
- LCG
- LCM
- LCT
- LCY
- STR2
- UCA2
- HCM
- HCA
- SRL2
- SRG
- SRM
- SRT
- MRL2
- MRG2
- SM-25
- CAC3
- UCAC
- RCC2
- MFC
- SHC
- GLC
- Ending

Dimensions



● MDC2-Y-6, 8, 10 (single acting retract type/without switch)

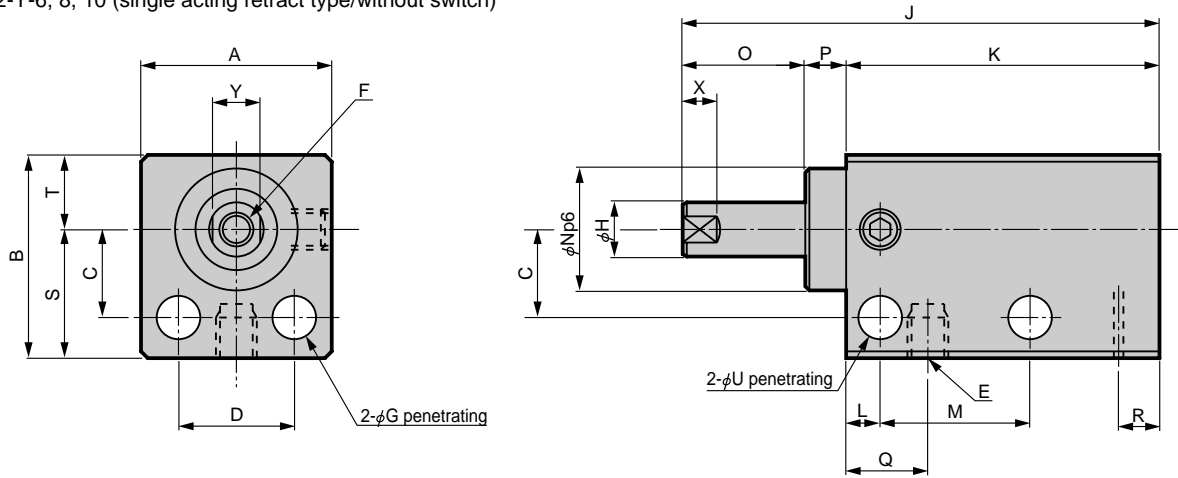

Model no.	Stroke length	A	B	C	D	E	F	G	H	J	K	L	M	N	O	P	Q	R	S	T	U	X	Y		
MDC2-Y-6	4	14	15	6.5	8.5	M3	M2.5 x	3.2	4	30	20	2.5	9	9	7	3	6	3	9.5	5.5	3.2	2.5	3.5		
	6						0.45			35	23		11		9									9	11
	8						depth 4			41	27		13		11										
MDC2-Y-8	4	16	17	7.5	10	M3	M3 x	3.2	5	31	21	2.5	9.5	11	7	3	6	3	10.5	6.5	3.2	2.5	4.5		
	6						0.5			36	24		11.5		9									11	
	8						depth 5			41	27		13.5		11										
MDC2-Y-10	4	16	17.5	8	10	M5	M3 x	3.2	6	32	22	2.5	9.5	11	7	3	7	3.5	11	6.5	3.2	2.5	5		
	6						0.5			37	25		11.5		9									13	
	10						depth 5			47	31		15.5												

● MDC2-YL-6, 8, 10 (single acting retract type/with switch)

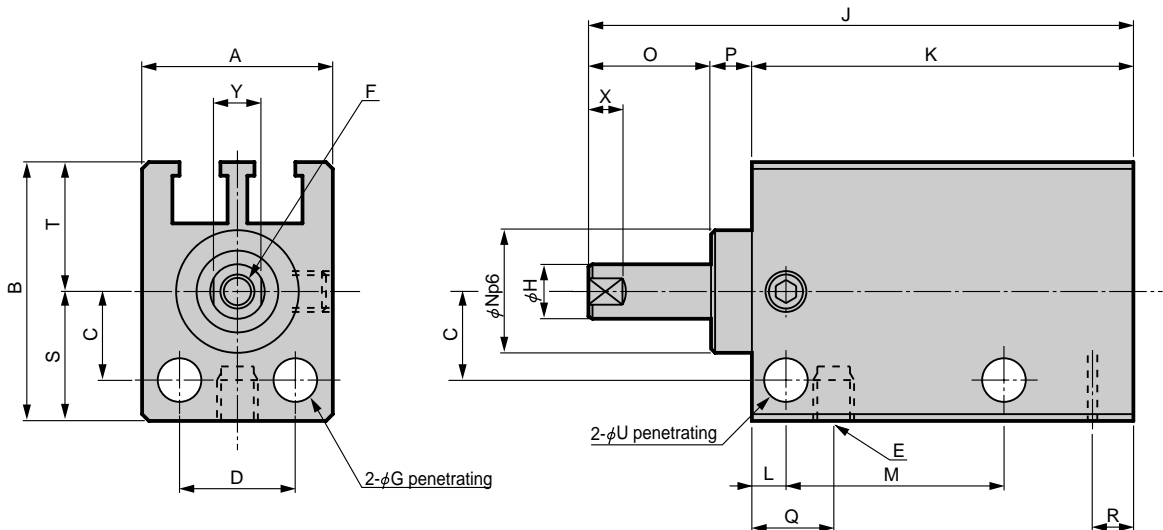

Note) Refer to page 984 for the switch installation dimensions.

Model no.	Stroke length	A	B	C	D	E	F	G	H	J	K	L	M	N	O	P	Q	R	S	T	U	X	Y		
MDC2-YL-6	4	14	19	6.5	8.5	M3	M2.5 x	3.2	4	35	25	2.5	14	9	7	3	6	3	9.5	9.5	3.2	2.5	3.5		
	6						0.45			40	28		16		9									9	11
	8						depth 4			46	32		18												
MDC2-YL-8	4	16	22	7.5	10	M3	M3 x	3.2	5	36	26	2.5	14.5	11	7	3	6	3	11	11	3.2	2.5	4.5		
	6						0.5			41	29		16.5		9									11	
	8						depth 5			46	32		18.5		11										
MDC2-YL-10	4	16	22	8	10	M5	M3 x	3.2	6	36	26	2.5	13.5	11	7	3	7	3.5	11	11	3.2	2.5	5		
	6						0.5			41	29		15.5		9									13	
	10						depth 5			51	35		19.5												

- SCP*2
- CMK2
- CMA2
- SCM
- SCG
- SCA2
- SCS
- CKV2
- CA/OV2
- SSD
- CAT
- MDC2**
- MVC
- SMD2
- MSD*
- FC*
- STK
- ULK*
- JSK/M2
- JSG
- JSC3
- USSD
- USC
- JSB3
- LMB
- STG
- STS/L
- LCS
- LCG
- LCM
- LCT
- LCY
- STR2
- UCA2
- HCM
- HCA
- SRL2
- SRG
- SRM
- SRT
- MRL2
- MRG2
- SM-25
- CAC3
- UCAC
- RCC2
- MFC
- SHC
- GLC
- Ending

Small direct mounting cylinder
Space saving structure



Small direct mounting cylinder, fine speed type

MDC2-F Series

● Bore size $\phi 6$, $\phi 8$, $\phi 10$

JIS symbol

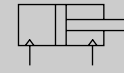

● Double acting



Specifications

Descriptions	MDC2-F/MDC2-LF (with switch)		
Bore size mm	$\phi 6$	$\phi 8$	$\phi 10$
Actuation	Double acting, single rod type		
Working fluid	Compressed air		
Max. working pressure MPa	0.7		
Min. working pressure MPa	0.15		0.1
Withstanding pressure MPa	1.05		
Ambient temperature $^{\circ}\text{C}$	5 to 60 Note 1		
Port size	M3		M5
Stroke tolerance mm	+0.5 0		
Working piston speed mm/s	1 to 200		
Cushion	None		
Lubrication	Must be oil free		
Allowable energy absorption J	A cylinder without cushion cannot absorb an energy generated by an external load. Use this with loadless, select a cushion type, or install an external shock absorber.		

Note 1: 40°C for types with proximity switches.

Stroke length

Model no.	Bore size (mm)	Standard stroke length (mm)	Max. stroke length (mm)	Min. stroke length with 2 switches (mm)		Min. stroke length with 1 switch (mm)	
				Reed switch	Proximity switch	Reed switch	Proximity switch
MDC2-F	$\phi 6$	4, 6, 8	8	6	4	4	4
	$\phi 8$	4, 6, 8	8	8	4	4	4
MDC2-LF	$\phi 10$	4, 6, 10	10	6	4	4	4

Note: Other than standard stroke length is not available.

Switch specifications

Descriptions	Reed 2 wire	Proximity 2 wire	Proximity 3 wire
	F0H/V	F2H/V	F3H/V
Applications	Programmable controller		Programmable controller, relay
Output method	-		NPN output
Power voltage	-	-	10 to 28 VDC
Load voltage	24 VDC	10 to 30 VDC	30 VDC or less
Load current	5 to 20mA (Note 1)	5 to 20mA (Note 1)	50mA or less
Current consumption	-	-	10mA or less (at ON state) at 24 VDC
Internal voltage drop	4 V or less		0.5 V or less
Light	Yellow LED (ON lighting)		
Leakage current	1mA or less		10 μA or less
Lead wire length (standard)	Standard 1m (oil resistant vinyl cabtire cord 2 conductor 0.15mm ²)		Standard 1m (oil resistant vinyl cabtire cord 3 conductor 0.15mm ²)
Maximum shock resistance	294m/s ²	980m/s ²	
Insulation resistance	20M Ω and over at 500 VDC megger		
Withstand voltage	No failure at 1000 VAC for one minute.		
Ambient temperature	-10 to + 60°C		
Protective structure	IEC standards IP67, JIS C 0920 (water tight type), oil resistance		

Note 1: Max. load current 20mA is the value at 25°C.

When ambient temperature around switch is higher than 25°C, the value is lower than 20mA. (5 to 10mA at 60°C)

Clean room specifications (Catalog No. CB-033SA)

● Dust generation preventing structure for use in clean room

MDC2-F

P7*

How to order

- Without switch

MDC2-F - **6** - **4**

- With switch

MDC2-LF - **6** - **4** - **F2V** - **R**

A Bore size

B Stroke length

C Switch model no. Note 1
Note 2
Note 3

D Switch quantity

Symbol	Descriptions			
A Bore size				
6	$\phi 6$			
8	$\phi 8$			
10	$\phi 10$			
B Stroke length (mm)				
	Bore size	$\phi 6$	$\phi 8$ $\phi 10$	
4	4	●	● ●	
6	6	●	● ●	
8	8	●	● ●	
10	10	—	— ●	
C Switch model no.				
Axial lead wire	Radial lead wire	Contact	Indicator	Lead wire
F0H*	F0V*	Reed	1 color indicator type	2-wire
F2H*	F2V*	Proximity		3-wire
F3H*	F3V*			
*Lead wire length				
Blank	1m (standard)			
3	3m (option)			
D Switch quantity				
R	1 on rod end			
H	1 on head end			
D	Two			

⚠ Note on selection guide

Note 1: Min. stroke length with two reed switches is 6mm for $\phi 6$, 8mm for $\phi 8$ and 6mm for $\phi 10$.

Note 2: MDC2 with reed switch cannot be installed on magnetic substance (iron plate, etc.). Failure to observe this may cause switch detection defective.

Note 3: MDC2 with proximity switch should be used at ambient temperature 40°C or less. Failure to observe this may cause switch detection defective.

<Example of model number>

MDC2-LF-6-4-F2V-R

Model: Small direct mounting cylinder, fine speed type

- A** Bore size : $\phi 6$ mm
- B** Stroke length : 4mm
- C** Switch model no. : Proximity switch F2V, lead wire 1m
- D** Switch quantity : 1 on rod end

How to order switch

SW - **F0H**

Switch model no.
(Item **C** above)

Dimensions

It is the same as the double acting single rod type MDC2 series. Refer to Page 970.

SCP*2
CMK2
CMA2
SCM
SCG
SCA2
SCS
CKV2
CA/OV2
SSD
CAT
MDC2
MVC
SMD2
MSD*
FC*
STK
ULK*
JSK/M2
JSG
JSC3
USSD
USC
JSB3
LMB
STG
STS/L
LCS
LCG
LCM
LCT
LCY
STR2
UCA2
HCM
HCA
SRL2
SRG
SRM
SRT
MRL2
MRG2
SM-25
CAC3
UCAC
RCC2
MFC
SHC
GLC
Ending

Small direct mounting cylinder
Space saving structure

Switch dimensions

● MDC2 switch installation position

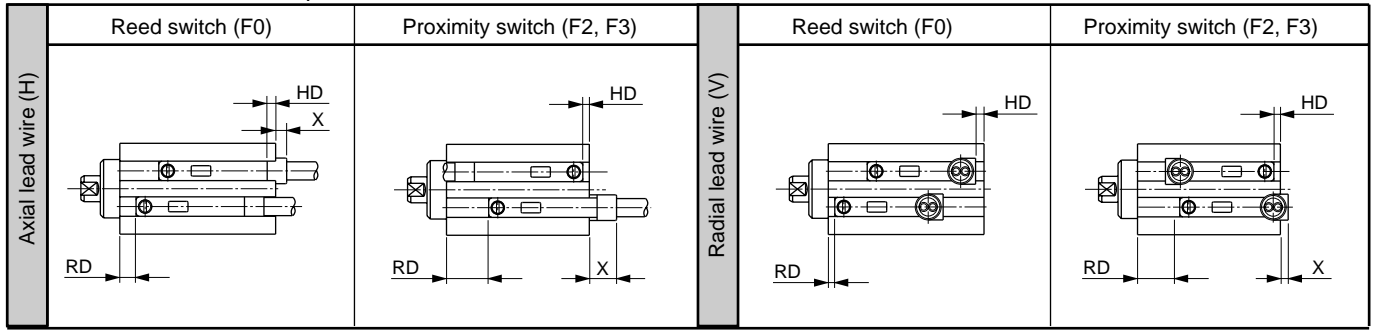

Note: This indicates switch installation position at shipment.

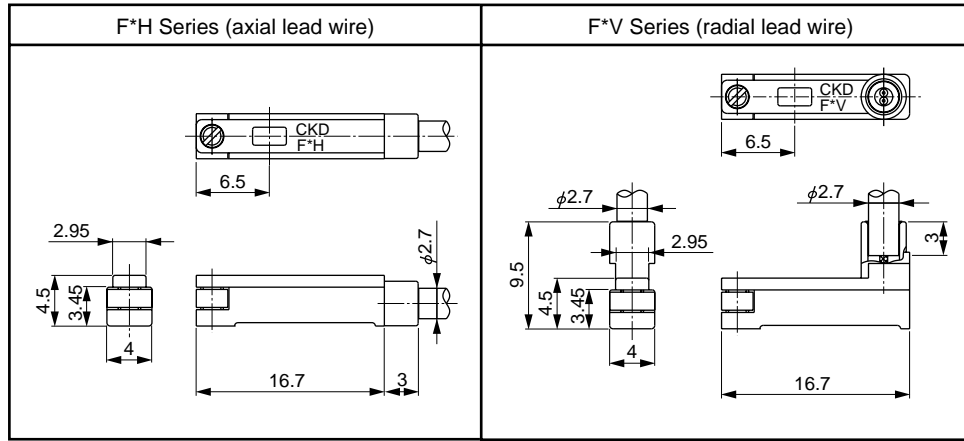

Note 1: Min. stroke length of 2 switches is as the below table.

Note 2: MDC2 with reed switch cannot be installed on magnetic substance (iron plate, etc.). Failure to observe this may cause switch detection defective.

Note 3: MDC2 with proximity switch should be used at ambient temperature 40°C or less. Failure to observe this may cause switch detection defective.

Min. stroke length (with 2 switches) (mm)

Bore size (mm)	Reed switch	Proximity switch
φ6	6	4
φ8	8	4
φ10	6	4

(mm)

Installation of switch		Reed switch									Proximity switch								
		FO _H									F2 _H F3 _H								
		RD			HD			X (Note 1)			RD			HD			X (Note 1)		
Bore size (mm)	Actuation	Stroke length (mm)			Stroke length (mm)			Stroke length (mm)			Stroke length (mm)			Stroke length (mm)			Stroke length (mm)		
		4	6	8 (10)	4	6	8 (10)	4	6	8 (10)	4	6	8 (10)	4	6	8 (10)	4	6	8 (10)
φ6	Double acting	1	1	1	-0.5	0	0	3.5	3	3	6.5	6.5	6.5	1	1	1	4.2	2.2	0.2
	Single acting extend type (X)	0	1	3	-1	0	0	4	3	3	6	7	9	0.5	0.5	0.5	4.7	2.7	0.7
	Single acting retract type (Y)	2.5	2.5	2.5	1.5	2.5	4.5	1.5	0.5	-1.5	6.5	6.5	6.5	4	5	7	1.7	-1.3	-5.3
φ8	Double acting	1	1	1	-1.5	0	0	4.5	3	3	6.5	6.5	6.5	1	1	1	4.2	2.2	0.2
	Single acting extend type (X)	1	2	3	-1.5	0	0	4.5	3	3	6.5	7.5	8.5	1	1	1	4.2	2.2	0.2
	Single acting retract type (Y)	2.5	2.5	2.5	2.5	3.5	4.5	0.5	-0.5	-1.5	6.5	6.5	6.5	5	6	7	0.2	-2.8	-5.8
φ10	Double acting	3.5	3.5	3.5	0.5	0.5	0.5	2.5	2.5	2.5	8	8	8	2.5	2.5	2.5	2.7	0.7	-3.3
	Single acting extend type (X)	4	5	7	0	0	0	3	3	3	8.5	9.5	11.5	2	2	2	3.2	1.2	-2.8
	Single acting retract type (Y)	3.5	3.5	3.5	1.5	2.5	4.5	1.5	0.5	-1.5	8	8	8	3.5	4.5	6.5	1.7	-1.3	-7.3

Note 1: X dimension shows projecting section of switch from the edge of groove. (A negative value shows hollowed dimensions.)

The upper row shows X dimension of axial lead wire type, while the lower row shows X dimension of radial lead wire type.

Max. sensitive position (RD, HD), operating range, hysteresis

(mm)

Descriptions		Proximity switch (F2H/V, F3H/V)				Reed switch (F0H/V)			
		Maximum sensitive position		Operating range	Hysteresis	Maximum sensitive position		Operating range	Hysteresis
Bore size (mm)	Actuation	RD	HD			RD	HD		
φ6	Double acting single rod	6.5	1	1.5 to 3.5	1.0 or less	1	-0.5	3.5 to 6.0	
	Single acting extend	7	1			1	-1		
	Single acting retract	7	5			2.5	2.5		
φ8	Double acting single rod	6.5	1	2.0 to 3.5	1.0 or less	1	-1.5	5.5 to 7.5	
	Single acting extend	7.5	1			2	-1.5		
	Single acting retract	6.5	6			2.5	3.5		
φ10	Double acting single rod	8	2.5	1.5 to 3.5	1.0 or less	3.5	0.5	4.5 to 6.0	
	Single acting extend	9.5	2			5	0		
	Single acting retract	8	5			3.5	2.5		