

Outstanding performance in extremely low pressure and low pressure ranges from 0.003 to 0.1 MPa.

Realizing high performance, energy saving, and compact size. Realize precise pressure control in a pressure range of 0.03 to 0.4 MPa.

Pilot pressure control with a nozzle flapper enables highly precise, stable precise pressure control in a setting pressure range between 0.003 to 0.4 MPa. Control performance is especially outstanding in extremely low to low pressure ranges between 0.003 and 0.1 MPa. The relief flow is high even with the *42mm compact size. This energy saving type also has low air consumption.

- **High precision pressure control**
Pressure control within $\pm 0.5\%$ of repeatability full scale and within 0.1% of the sensitivity full scale is possible.
- **Stable flow characteristics with small pressure drop**

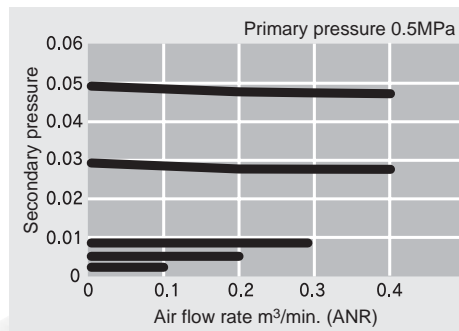

- **Set extremely low pressures**
A pressure as low as 0.003MPa can be set (RP1000-8-02).

- **High relief flow**

- **Energy saving with small air consumption**

■ Pressure control

- **Extremely smooth pressure setting**

- **Compact 42mm, light weight 250g**
Compact and light weight design incorporates aluminum.

- **Modular type**
Connect with the C1000 Series filter and oil mist filter.

- **Highly reliable material for moving sections**
Ozone resistant material is used as a standard for the moving section's rubber material to prevent deterioration.

- **Nongrease specification fluid passage section**

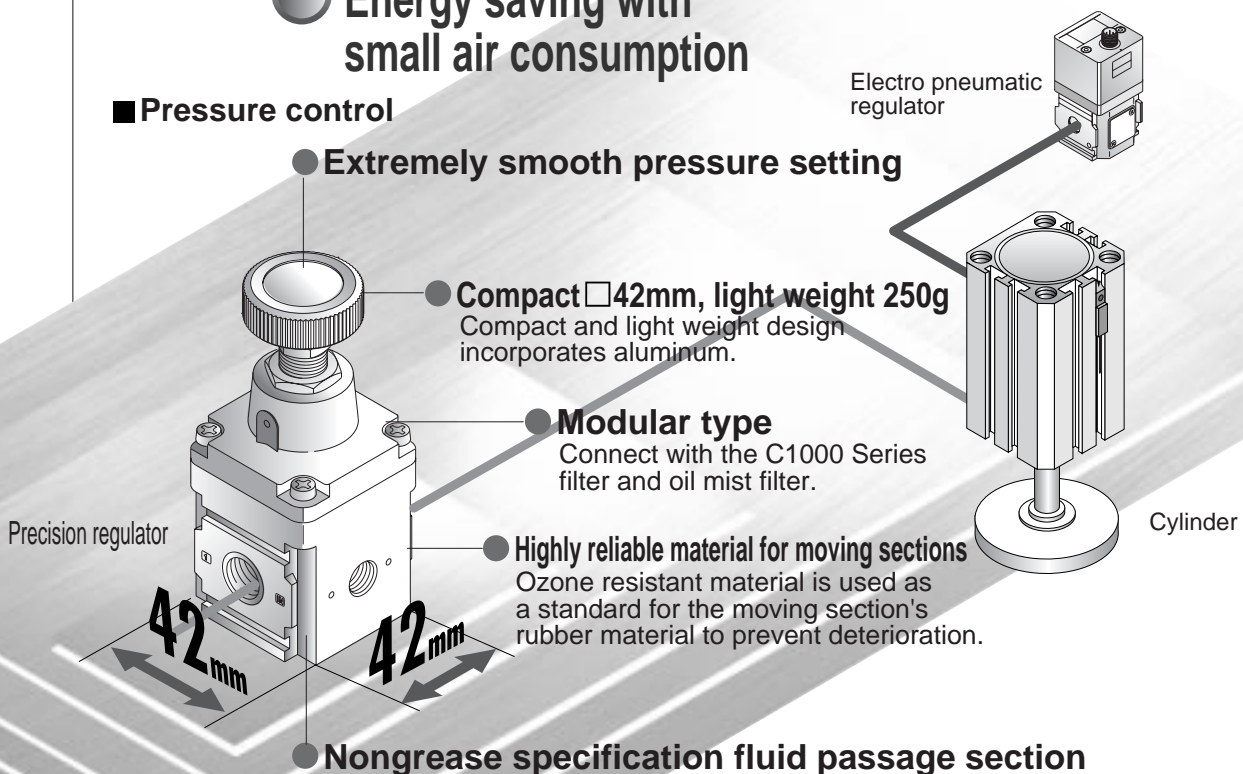

High performance, energy saving, compact

RP1000 Series

CKD

- Refrigerating type dryer
- Desiccant type dryer
- High polymer membrane dryer
- Air filter
- Auto. drain / others
- F.R.L. (Module unit)
- F.R.L. (Separate)
- Compact F.R.
- Precise regulator
- F.R.L. (Related products)
- Clean F.R.
- Electro pneumatic regulator
- Air booster
- Speed control valve
- Silencer
- Check valve / others
- Joint / tube
- Vacuum filter
- Vacuum regulator
- Suction plate
- Magnetic spring buffer
- Mechanical pressure SW
- Electronic pressure SW
- Contact / close contact conf. SW
- Air sensor
- Pressure SW for coolant
- Small flow sensor
- Small flow controller
- Flow sensor for air
- Flow sensor for water
- Total air system
- Total air system (Gamma)
- Ending

Pressure setting: Max. 0.85MPa

Long-life, high flow perfect for balancer applications.

Realizing high performance, long service, and high exhaust flow. Realize precise pressure control in a pressure range of 0.03 to 0.85MPa.

The RP2000 Series incorporates pilot pressure control using a nozzle flapper similar to the 1000 Series. However, this *50mm compact high exhaust flow has high relief. Low sliding packing is used for moving parts, extending parts life. This type has outstanding durability and sufficient supply/discharge at optimum high frequency and high response required for devices such as balancers.

High precision pressure control
Pressure control within $\pm 0.5\%$ of repeatability full scale and within 0.2% of the sensitivity full scale is possible.

50mm • 470g
Compact aluminum body with high flow.

Foreign matter entry prevention
A mesh filter is installed as a standard on the IN side.

Modular type
Connect with the C3000 and C4000 Series filter and oil mist filter.

Long service life
Low sliding packing is adapted for moving sections, and strong grease is used for dry air.

Stable flow characteristics with small pressure drop

High relief flow

● Cylinder bore size and corresponding speed (guide)	
$\phi 80$	1000mm/s
$\phi 100$	900mm/s
$\phi 125$	600mm/s

■ Balancer

High performance, long service life, and high exhaust flow

RP2000 Series

- Refrigerating type dryer
- Desiccant type dryer
- High polymer membrane dryer
- Air filter
- Auto. drain / others
- F.R.L. (Module unit)
- F.R.L. (Separate)
- Compact F.R.
- Precise regulator**
- F.R.L. (Related products)
- Clean F.R.
- Electro pneumatic regulator
- Air booster
- Speed control valve
- Silencer
- Check valve / others
- Joint / tube
- Vacuum filter
- Vacuum regulator
- Suction plate
- Magnetic spring buffer
- Mechanical pressure SW
- Electronic pressure SW
- Contact / close contact cont. SW
- Air sensor
- Pressure SW for coolant
- Small flow sensor
- Small flow controller
- Flow sensor for air
- Flow sensor for water
- Total air system
- Total air system (Gamma)
- Ending

Precision regulator
F.R.L. unit



Pneumatic components (F.R.L. unit precision type)

Safety precautions

Always read this section before starting use.
Refer to Intro 67 for general precautions.

Precision regulator RP1000/2000 Series

Design & Selection

⚠ WARNING

- Use this product in accordance with the specifications range.
- Working fluid must be clean air from which solids, water and oil have been sufficiently removed using a dryer, filter and oil mist filter. Never supply oiled air. When secondary pressure, etc., is turned off, air on the secondary side will pass through the regulator and be discharged from the EXH port. Thus, if secondary piping or inside of the load side is dirty, performance is adversely affected so characteristics will deteriorate. Keep the inside of pipes clean.

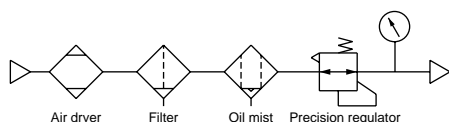

⚠ CAUTION

- Keep the pressure difference between the primary and secondary sides to 0.1 MPa and over. Note that, for RP1000-8-04, if the set pressure is 0.3 MPa and over, keep the pressure difference at 0.2 MPa and over.
(Precautions for RP1000)
When using under conditioned with a small pressure difference between the primary and secondary sides, the secondary pressure could pulsate. In this case, decrease the pressure setting (high pressure → low pressure). Another method is to set the primary pressure to an extremely high level or to somewhat lower the setting pressure, and restrict the secondary side line. Consult with CKD if the pulsation still does not cease. When using with low friction cylinder having constant leak, secondary pressure may pulsate depending on working conditions. In this case, restrict the secondary side line and decrease the pressure setting (high pressure → low pressure) to attenuate pulsation. Consult with CKD if the pulsation still does not cease.
(Precautions for RP2000)
If the pressure difference between primary and secondary sides is large and secondary side piping is large, secondary pressure could pulse during low flow. In this case, set the primary side to the secondary side pressure +0.1 to 0.2 MPa or restrict the secondary side line. Consult with CKD if the pulsation still does not cease.
- If the regulator is repeatedly turned ON and OFF with the directional control valve on the primary side, the set pressure may change greatly. Thus, the directional control valve should be installed on the secondary side.
- Install a safety device where an output pressure exceeding the regulator's set pressure value could result in damage or faulty operation of secondary side devices.
- Do not operate the pressure adjustment knob while the primary side is released to the atmosphere as performance could deteriorate.

Installation & Adjustment

⚠ CAUTION

- Check IN and OUT indications indicating the air inlet and outlet before connecting. Reverse connection could result in improper operation. If connected reversely, malfunction may be caused.
- Do not move or swing the product holding the adjustment knob on the regulator.
- Avoid installing this product where vibration and impact are present.

- Flush air pipes before connecting the regulator.
- Check that sealing tape is not caught when piping.
- When using regulator in parallel as shown below, do not use the OUT side as a closed circuit. If a closed circuit is required, set a check valve at the regulator's OUT side.

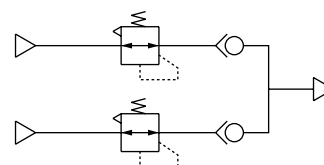

- Refrigerating type dryer
- Desiccant type dryer
- High polymer membrane dryer
- Air filter
- Auto. drain / others
- F.R.L. (Module unit)
- F.R.L. (Separate)
- Compact F.R.
- Precision regulator
- F.R.L. (Related products)
- Clean F.R.
- Electro pneumatic regulator
- Air booster
- Speed control valve
- Silencer
- Check valve / others
- Joint / tube
- Vacuum filter
- Vacuum regulator
- Suction plate
- Magnetic spring buffer
- Mechanical pressure SW
- Electronic pressure SW
- Contact / close contact conf. SW
- Air sensor
- Pressure SW for coolant
- Small flow sensor
- Small flow controller
- Flow sensor for air
- Flow sensor for water
- Total air system
- Total air system (Gamma)
- Ending

- Install the regulator so that the EXH is not plugged.
- When installing on a panel, completely loosen the pressure adjustment knob, and insert the body into the 12.5 diameter panel hole. Then, fix to the tightening panel with the panel mounting nut. Next, turn the pressure adjustment knob, and assemble it onto the body.
(Precautions for RP2000)
If the product is installed on the panel in a horizontal direction, the panel could be damaged by the product weight and vibration.

- Apply adequate torque when connecting pipes.
 - To prevent air leak and to protect thread.
 - Tighten by hand first, then use a tool, to prevent screw thread damage.

(Recommended value)

Port thread	Tightening torque N·m
Rc1/8	3 to 5
Rc1/4	6 to 8
Rc3/8	13 to 15

During use & Maintenance

CAUTION

- Working air quality
 - Use only compressed air. Air containing corrosive gases, fluids or chemicals could result in improper pressure adjustment due to body damage or rubber deterioration.
- Working environment
 - Avoid using the regulator in the following environment.
 - Place where the ambient temperature exceeds -5 to 60°C.
 - Where air freezes.
 - Where water drip and cutting lubricant contact to the product.
 - Highly humid places where dew condenses due to temperature fluctuations.
 - Where sea breeze or salt water could come in contact.
 - If there is atmosphere of corrosive gas and liquid and chemical material.
 - Where the product is exposed to direct sun lay.
 - With the precision regulator RP1000, the setting pressure fluctuates by approx. 0.12kPa/°C. The pressure tends to drop when the temperature rises.
- Use
 - Air constantly leaks from the bleed port. This is necessary for precise pressure control, so do not plug the hole.
 - Check primary pressure before setting pressure.
 - Do not set a pressure higher than primary pressure.
 - Turn the pressure adjustment knob clockwise to increase secondary pressure, and counterclockwise to lower pressure.
 - Pressure is set in the depressurizing direction (high pressure → low pressure), so a highly precise setting can be made.
 - After adjusting pressure, tighten the lock nut, and then fix the knob.
 - The precision regulator RP1000 exhaust valve has a metal seal, so a small amount of secondary air will leak.

Maintenance

- Pneumatic components must be disassembled and assembled by a qualified worker.
- Personnel involved in this step must have passed the Pneumatic Pressure Skill Test Class 2 or higher.
- Read the relevant product instruction manual thoroughly and fully familiarize yourself with work before disassembling or assembling the pneumatic component.
- Personnel must be fully familiar with pneumatic component structure and operational principles and safety requirements.
- Before servicing the product, turn power off, stop the compressed air supply, and check that there is no residual pressure.

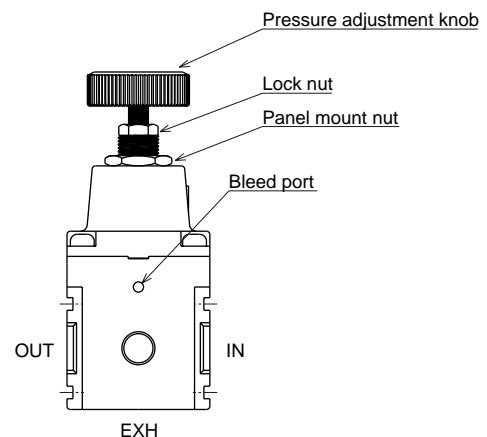

Refrigerating type dryer
Desiccant type dryer
High polymer membrane dryer
Air filter
Auto. drain / others
F.R.L. (Module unit)
F.R.L. (Separate)
Compact F.R.
Precise regulator
F.R.L. (Related products)
Clean F.R.
Electro pneumatic regulator
Air booster
Speed control valve
Silencer
Check valve / others
Joint / tube
Vacuum filter
Vacuum regulator
Suction plate
Magnetic spring buffer
Mechanical pressure SW
Electronic pressure SW
Contact / close contact cont. SW
Air sensor
Pressure SW for coolant
Small flow sensor
Small flow controller
Flow sensor for air
Flow sensor for water
Total air system
Total air system (Gamma)

Ending

Precision regulator
F.R.L. unit

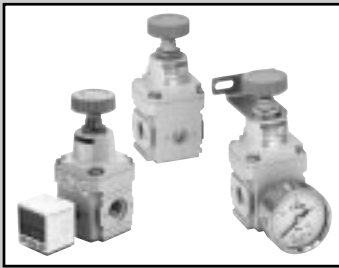

Precision regulator

RP1000 Series

● Port size: Rc 1/4

JIS symbol



Specifications

Descriptions	RP1000-8-02	RP1000-8-04	RP1000-8-07
Working fluid	Clean compressed air (refer to recommended air circuit on page 672)		
Max. working pressure Mpa	1.0		
Min. working pressure Mpa	Setting pressure + 0.1 Note 1		
Withstanding pressure Mpa	1.5		
Ambient temperature, fluid temperature °C	-5 to 60 (no freezing) Note 3		
Set pressure range Mpa	0.003 to 0.2	0.005 to 0.4	0.005 to 0.7
Sensitivity	Within 0.1% of full scale		
Repeatability	Within ±0.5% of full scale		
Air consumption Note 2 l/min. (ANR)	1.3 or less		3.4 or less
Port size	Rc1/4		
Pressure gauge port size	Rc1/8		
Weight g	250		

Note 1. Flow rate of the secondary side is to be zero. If the set pressure is 0.3MPa and over, increase +0.2MPa in the set pressure.

Note 2. The primary pressure is to be 0.7MPa. Air is released to atmosphere normally.

Note 3. The range is -5 to 50°C when a digital pressure sensor is used.

How to order

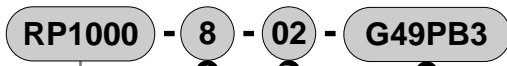

Model
RP1000: Precision regulator

A Port size		B Setting pressure range		C Attachment (attached)	
8	Rc1/4	02	MAX. 0.2MPa	Blank	Without attachment
		04	MAX. 0.4MPa	G49P	Pressure gauge (G49D-6-*)
		07	MAX. 0.7MPa	B3	L type bracket
				R2	Digital pressure sensor

Note 1: A pressure gauge and a bracket are attached.

Note 2: A pressure gauge as same pressure range as the regulator is attached.

Note 3: One R1/8 plug is attached to the product.

Discrete attachment model no.

Model	Discrete attachment model no.
RP1000-8-02-G49P	G49D-6-P02
RP1000-8-04-G49P	G49D-6-P04
RP1000-8-07-G49P	G49D-6-P10
RP1000-8- ⁰² / ₀₄ / ₀₇ -B3	B131
RP1000-8- ⁰² / ₀₄ / ₀₇ -R2	PPX-R10N-6M

Clean room specifications (catalog No. CB-033SA)

● Dust generation preventing structure for use in cleanrooms

RP1000 - - P70

Internal structure and parts list

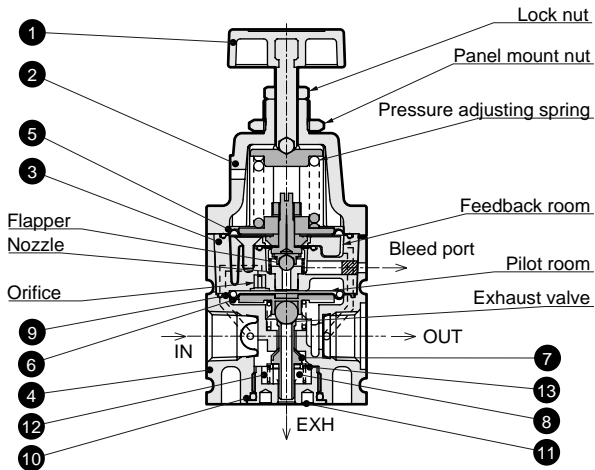

No.	Parts name	Material
1	Pressure adjustment knob	Polyacetal resin, stainless steel
2	Cover	Aluminum alloy die-casting
3	Pilot body assembly	Aluminum alloy die-casting, etc.
4	Body	Aluminum alloy die-casting
5	Pilot diaphragm	Hydrogen nitrile rubber
6	Main diaphragm	Hydrogen nitrile rubber
7	Valve	Hydrogen nitrile rubber, stainless steel
8	Bottom rubber	Silicon rubber
9	O ring	Nitrile rubber
10	O ring	Hydrogen nitrile rubber
11	Bottom plug	Brass, electroless nickel plating
12	Spring	Stainless steel
13	Valve adaptor	Aluminum alloy

Part No. 12 and 13 cannot be used for 0.2 or 0.4 MPa.

Operational explanation

Air supplied from IN side is stopped its flow to OUT side by the 7 valve. Some supplied air passes through the orifice to flow into the pilot room. If the 1 pressure adjustment knob is rotated, the pressure adjustment spring is compressed, and the 5 pilot diaphragm and the flapper are pushed down to close the nozzle.

If the pressure in the pilot room rises, 6 main diaphragm is forced lower to open 7 valve, and to supply air to OUT side. The entered air is flowed into the feedback room, and functions to the 5 pilot diaphragm. If the diaphragm is forced upward until reach the pressure of regulator spring, the 5 pilot diaphragm and flapper is forced upward to open the nozzle, and extremely small air is released to the atmosphere to reduce pressure in the pilot room. At the same time, OUT side pressure functions to the 6 main diaphragm to force upward, the 7 valve is closed and set pressure is maintained. Air is consumed and the pressure drops in OUT side, the pressure in feedback room also drops. The 5 pilot diaphragm and the flapper are forced lower to close the nozzle.

If the pressure in the pilot room rises, and the pressure functions to the 6 main diaphragm to open the 7 valve. This compensates pressure drops. If OUT side pressure increases higher than the set pressure, the pressure in feedback room also increases. The 5 pilot diaphragm and the flapper are forced upward to open the nozzle. This allows the pressure in the pilot room to decrease, and the 6 main diaphragm is forced upward to open the exhaust valve, and the surplus pressure is exhausted from EXH port in OUT side to the atmosphere.

This pilot pressure control method with precise pressure control enables precise pressure control following extremely small pressure deviation.

Repair parts list

0.2, 0.4MPa

Model no.	No.
RP1000-PILOT-ASSY	3 5
RP1000-DIAPHRAGM-ASSY	6 9
RP1000-VALVE-ASSY	7 8 10

0.7MPa

Model no.	No.
RP1000-PILOT-ASSY-07	3 5
RP1000-DIAPHRAGM-ASSY-07	6 9
RP1000-VALVE-ASSY	7 8 10

The RP1000-VALVE-ASSY is common to 0.2 and 0.4 MPa models.

Dimensions

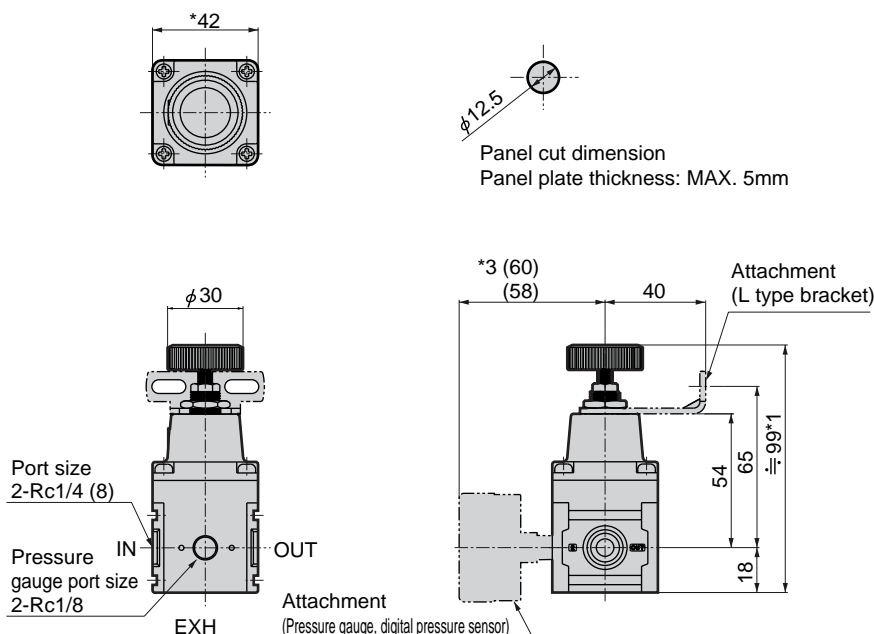

- *1: Dimension at setting pressure 0MPa
- *2: Pressure gauge, digital pressure sensor and bracket are optional.
- *3: Dimension when digital pressure sensor assembled.

Pressure gauge
P02
- G49D-6- P04
P10

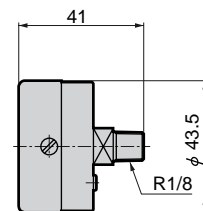

L type bracket
- B131

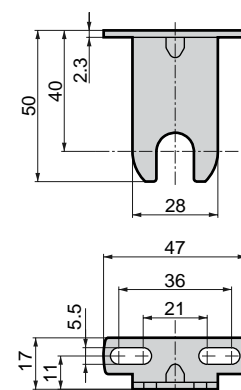

Refrigerating type dryer
Desiccant type dryer
High polymer membrane dryer
Air filter
Auto. drain / others
F.R.L. (Module unit)
F.R.L. (Separate)
Compact F.R.
Precise regulator
F.R.L. (Related products)
Clean F.R.
Electro pneumatic regulator
Air booster
Speed control valve
Silencer
Check valve / others
Joint / tube
Vacuum filter
Vacuum regulator
Suction plate
Magnetic spring buffer
Mechanical pressure SW
Electronic pressure SW
Contact / close contact cont. SW
Air sensor
Pressure SW for coolant
Small flow sensor
Small flow controller
Flow sensor for air
Flow sensor for water
Total air system
Total air system (Gamma)

Ending

Precision regulator
F.R.L. unit

Dimensions

● PPX-R10N-6M

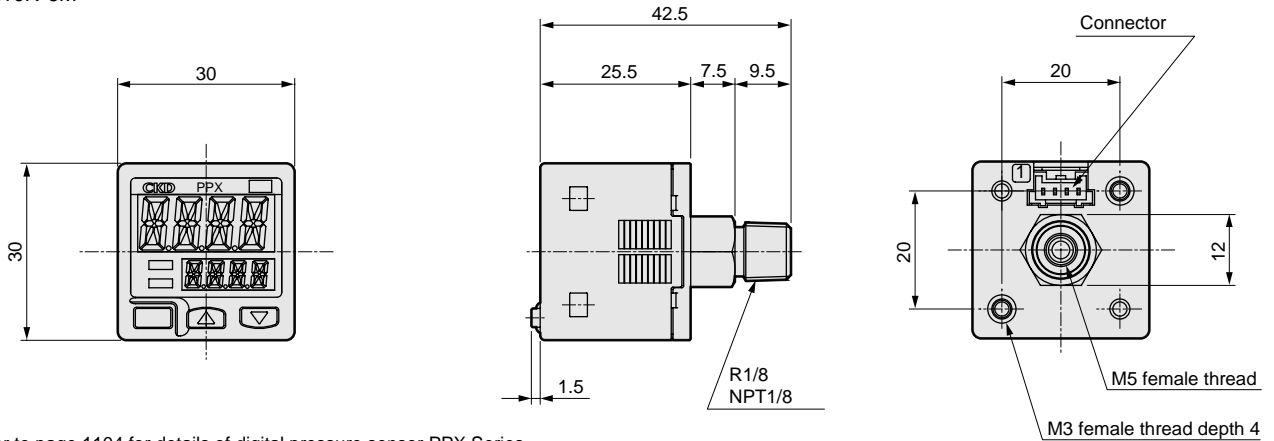

Note: Refer to page 1104 for details of digital pressure sensor PPX Series.

Flow characteristics

● RP1000-8-07

● RP1000-8-04

● RP1000-8-02

● RP1000-8-02

(Flow characteristics at low pressure)

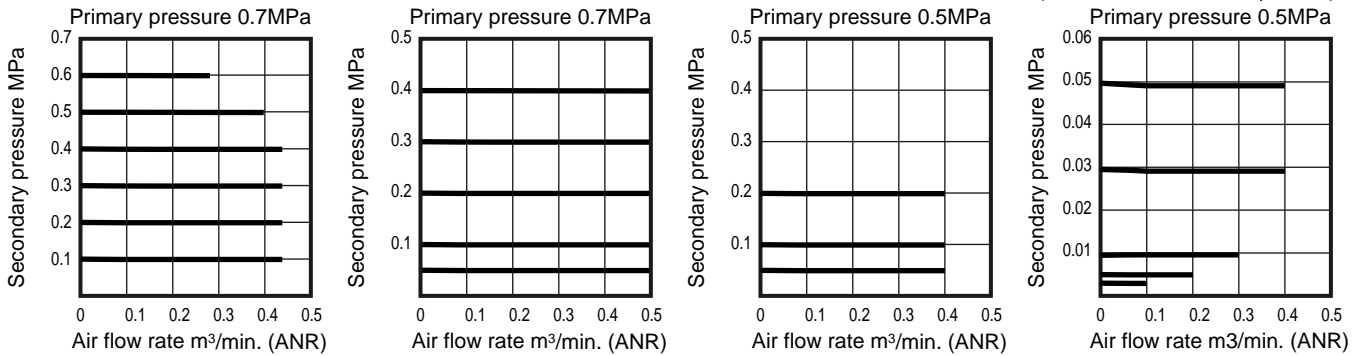

Relief flow characteristics

● RP1000-8-07

● RP1000-8-04

● RP1000-8-02

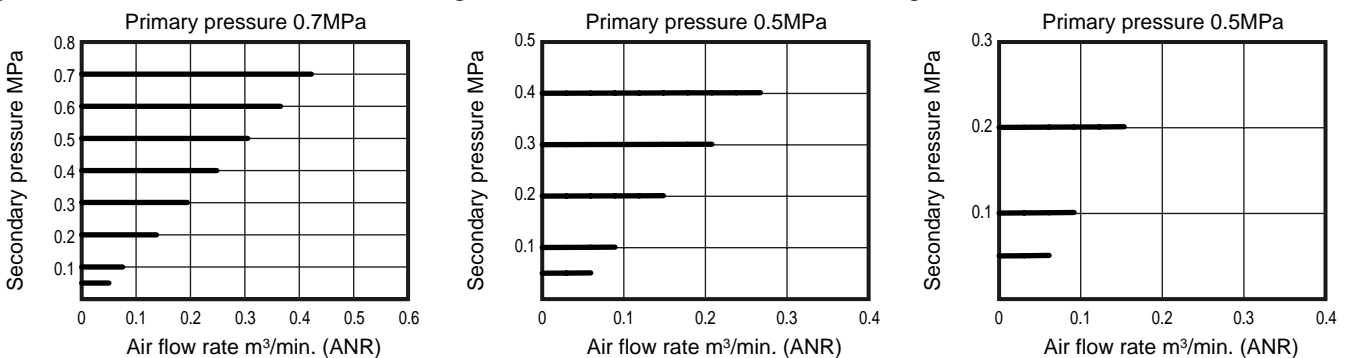

Pressure characteristics

● RP1000-8-07

● RP1000-8-04

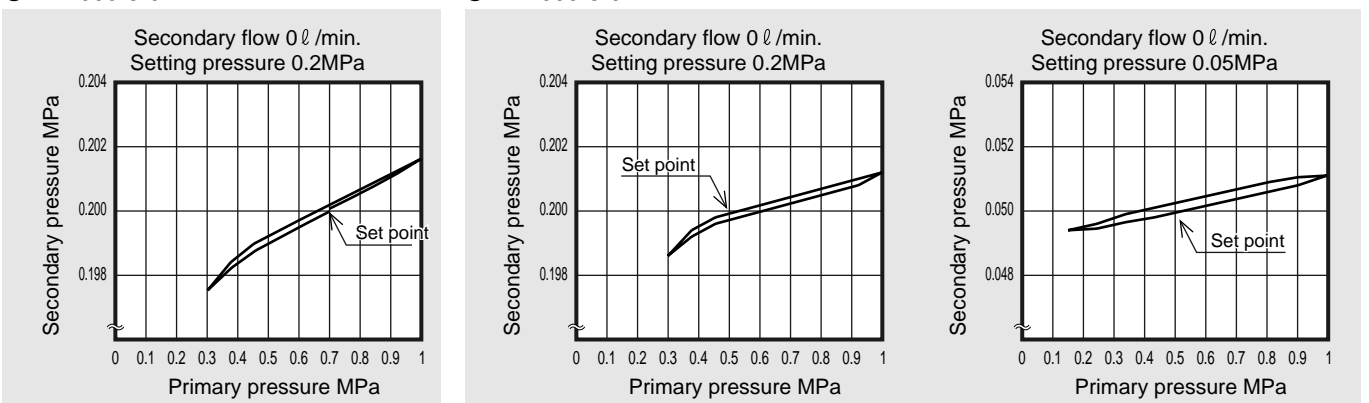

- Refrigerating type dryer
- Desiccant type dryer
- High polymer membrane dryer
- Air filter
- Auto. drain / others
- F.R.L. (Module unit)
- F.R.L. (Separate)
- Compact F.R.
- Precise regulator
- F.R.L. (Related products)
- Clean F.R.
- Electro pneumatic regulator
- Air booster
- Speed control valve
- Silencer
- Check valve / others
- Joint / tube
- Vacuum filter
- Vacuum regulator
- Suction plate
- Magnetic spring buffer
- Mechanical pressure SW
- Electronic pressure SW
- Contact / close contact conf. SW
- Air sensor
- Pressure SW for coolant
- Small flow sensor
- Small flow controller
- Flow sensor for air
- Flow sensor for water
- Total air system
- Total air system (Gamma)
- Ending

Pressure characteristics

● RP1000-8-02

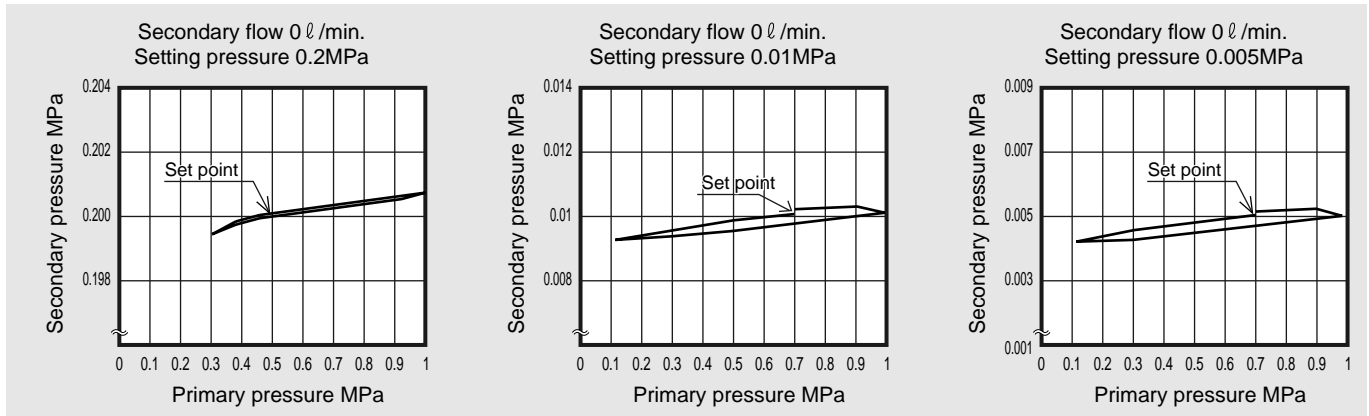

Cylinder speed range of RP1000

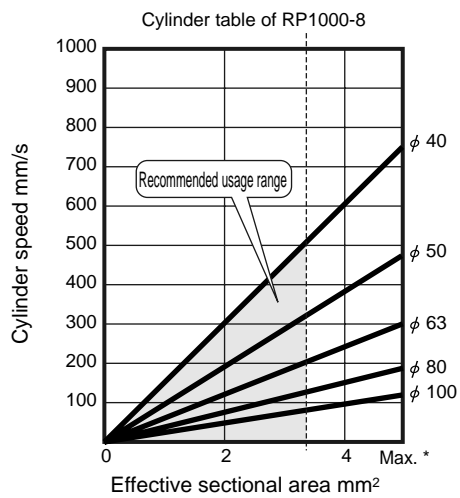

This cylinder table shows available range according to air supply / exhaust flow rate of precision regulator and required consumption flow rate at cylinder PUSH/PULL.

----- Recommended cylinder line (70% of maximum flow rate is recommended)

* Max. cylinder line (Cylinder directly installed)

Note: Using at a speed higher than maximum could cause relief faults.

Example of precise pressure control system

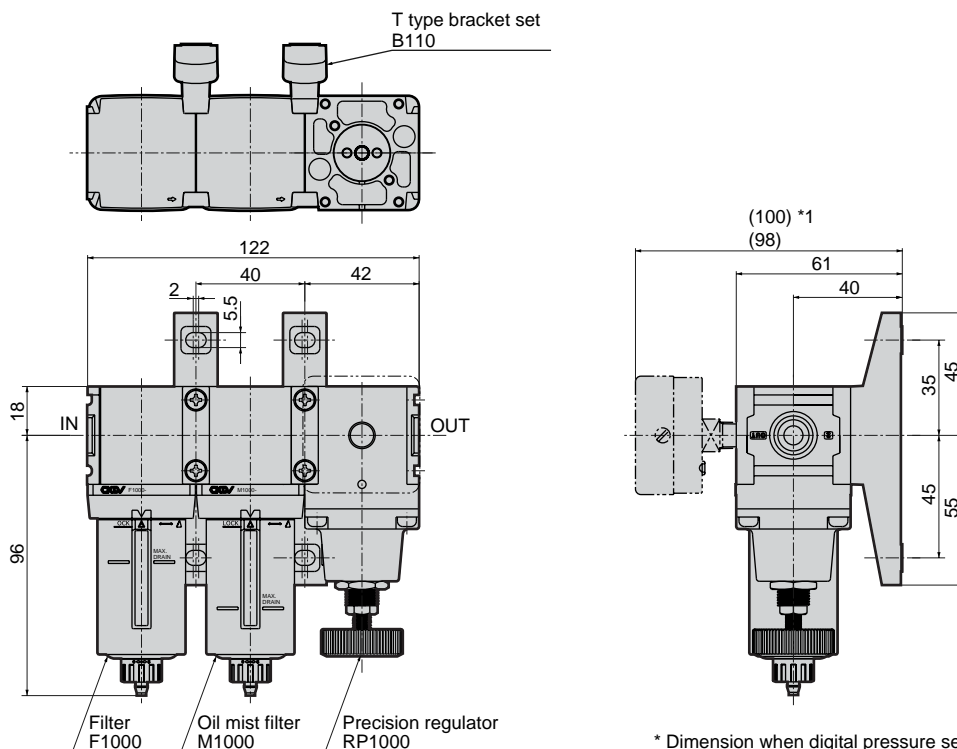

* Dimension when digital pressure sensor assembled.

* Consult with CKD if required for assembly.

Applicable model	Filter	Oil mist filter	Precision regulator	T type bracket set
Model	F1000	M1000	RP1000	B110 (2 pcs.)

- Refrigerating type dryer
- Desiccant type dryer
- High polymer membrane dryer
- Air filter
- Auto. drain / others
- F.R.L. (Module unit)
- F.R.L. (Separate)
- Compact F.R.
- Precise regulator
- F.R.L. (Related products)
- Clean F.R.
- Electro pneumatic regulator
- Air booster
- Speed control valve
- Silencer
- Check valve / others
- Joint / tube
- Vacuum filter
- Vacuum regulator
- Suction plate
- Magnetic spring buffer
- Mechanical pressure SW
- Electronic pressure SW
- Contact / close contact conf. SW
- Air sensor
- Pressure SW for coolant
- Small flow sensor
- Small flow controller
- Flow sensor for air
- Flow sensor for water
- Total air system
- Total air system (Gamma)

Ending

Precision regulator
F.R.L. unit

Refrigerating type dryer
 Desiccant type dryer
 High polymer membrane dryer
 Air filter
 Auto. drain / others
 F.R.L. (Module unit)
 F.R.L. (Separate)
 Compact F.R.
 Precise regulator
 F.R.L. (Related products)
 Clean F.R.
 Electro pneumatic regulator
 Air booster
 Speed control valve
 Silencer
 Check valve / others
 Joint / tube
 Vacuum filter
 Vacuum regulator
 Suction plate
 Magnetic spring buffer
 Mechanical pressure SW
 Electronic pressure SW
 Contact / close contact conf. SW
 Air sensor
 Pressure SW for coolant
 Small flow sensor
 Small flow controller
 Flow sensor for air
 Flow sensor for water
 Total air system
 Total air system (Gamma)
 Ending

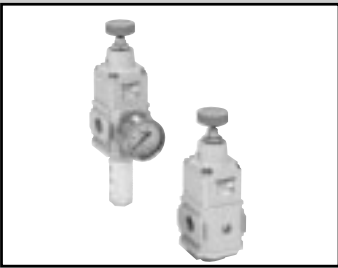

Precision regulator

RP2000 Series

● Port size: Rc 1/4, Rc3/8

JIS symbol



Specifications

Descriptions	RP2000-8-08	RP2000-10-08
Working fluid	Clean compressed air (refer to recommended air circuit on page 672)	
Max. working pressure Mpa	1.0	
Min. working pressure Mpa	Setting pressure + 0.1 Note 1	
Withstanding pressure Mpa	1.5	
Ambient temperature, fluid temperature °C	-5 to 60 (no freezing) Note 3	
Set pressure range Mpa	0.03 to 0.85	
Sensitivity	Within 0.2% of full scale	
Repeatability	Within ±0.5% of full scale	
Air consumption ℓ /min (ANR)	5 or less Note 2	
Port size	Rc1/4	Rc3/8
Exhaust side port size	Rc3/8	
Pressure gauge port size	Rc1/8	
Weight g	470	

Note 1. Flow rate of the secondary side is to be zero.

Note 2. Conditions where the primary pressure is 0.7MPa and set pressure is 0.3MPa. Consumed air is normally released to the atmosphere from the bleed port and EXH port. So, air consumption is the total of consumption volume released from the bleed port and EXH port. Air 1ℓ/min. (ANR) or less is released from EXH port.

Note 3. The range is -5 to 50°C when a digital pressure sensor is used.

How to order

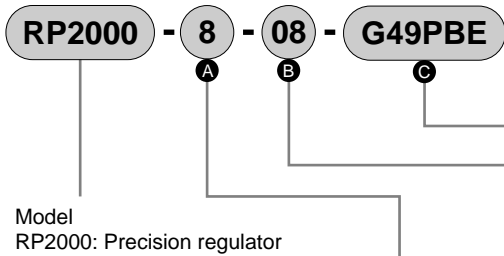

Model
 RP2000: Precision regulator

A Port size		B Setting pressure range		C Attachment	
8	Rc1/4	08	MAX. 0.85MPa	Blank	Without attachment
10	Rc3/8			G49P	Pressure gauge
				B	C type bracket
				E	Silencer
				R2	Digital pressure sensor

Note 1: If the port size Rc1/2 is required, use a piping adapter set (model no.: A400-15).

Note 2: Attachment is attached.

Note 3: The piping adapter set and C bracket cannot be used together.

Note 4: One R1/8 plug is attached to the product.

Discrete attachment model no.

Attachment symbol	Discrete attachment model no.
G49P	G49D-6-P10
B	B220
E	SLW-10A
R2	PPX-R10N-6M

Clean room specifications (catalog No. CB-033SA)

● Dust generation preventing structure for use in cleanrooms

RP2000 P70

Internal structure and parts list

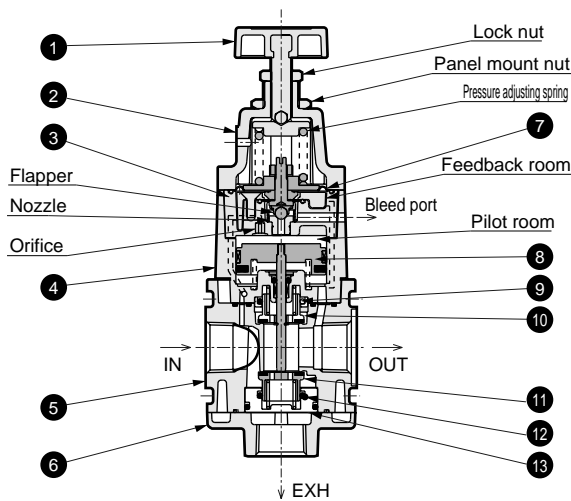

No.	Parts name	Material
1	Pressure adjustment knob	Polyacetal resin, stainless steel
2	Cover	Aluminum alloy die-casting
3	Pilot body assembly	Aluminum alloy die-casting, etc.
4	Top body assembly	Aluminum alloy die-casting, etc.
5	Body	Aluminum alloy die-casting
6	Exhaust adaptor	Aluminum alloy die-casting
7	Pilot diaphragm	Hydrogen nitrile rubber
8	Piston assembly	Aluminum, stainless steel, etc.
9	O ring	Nitrile rubber
10	Exhaust valve	Brass, hydrogen nitrile rubber
11	Air supply valve	Brass, hydrogen nitrile rubber
12	O ring	Nitrile rubber
13	Bottom cap	Brass

Operational explanation

Air supplied from IN side is stopped its flow to OUT side by the air supply valve. Some supplied air passes through the orifice to flow into the pilot room. If the ① pressure adjustment knob is rotated, the pressure adjustment spring is compressed, and the ⑦ pilot diaphragm and the flapper are pushed down to close the nozzle.

If the pressure in the pilot room rises, piston is forced lower to open ⑪ air supply valve, and to supply air to OUT side. The entered air is flowed into the feedback room, and functions to the ⑦ pilot diaphragm. If the diaphragm is forced upward until reach the pressure of regulator spring, the ⑦ pilot diaphragm and flapper is forced upward to open the nozzle, and extremely small air is released to the atmosphere to reduce pressure in the pilot room.

At the same time, OUT side pressure functions to the piston to force upward, the ⑪ air supply valve is closed and set pressure is maintained. Air is consumed and the pressure drops in OUT side, the pressure in feedback room also drops. The ⑦ pilot diaphragm and the flapper are forced lower to close the nozzle.

If the pressure in the pilot room rises, and the pressure functions to the piston to open the ⑪ air supply valve. This compensates pressure drops. If OUT side pressure increases higher than the set pressure, the pressure in feedback room also increases. The ⑦ pilot diaphragm and the flapper are forced upward to open the nozzle.

This allows the pressure in the pilot room to decrease, and the piston is forced upward to open the ⑩ exhaust valve, and the surplus pressure is exhausted from EXH port in OUT side to the atmosphere.

This pilot pressure control method with precise pressure control enables precise pressure control following extremely small pressure deviation.

Repair parts list

No.	Parts name	Model no.
3	Pilot body assembly	RP2000-PILOT-ASSY
7	Pilot diaphragm	
4	Top body assembly	RP2000-TOP-BODY-ASSY
11	Air supply valve	RP2000-BTM-VALVE-ASSY
12	O ring	
13	Bottom cap	

Note: Part no. (8), (9) and (10) are contained in top body assembly (4).

Dimensions

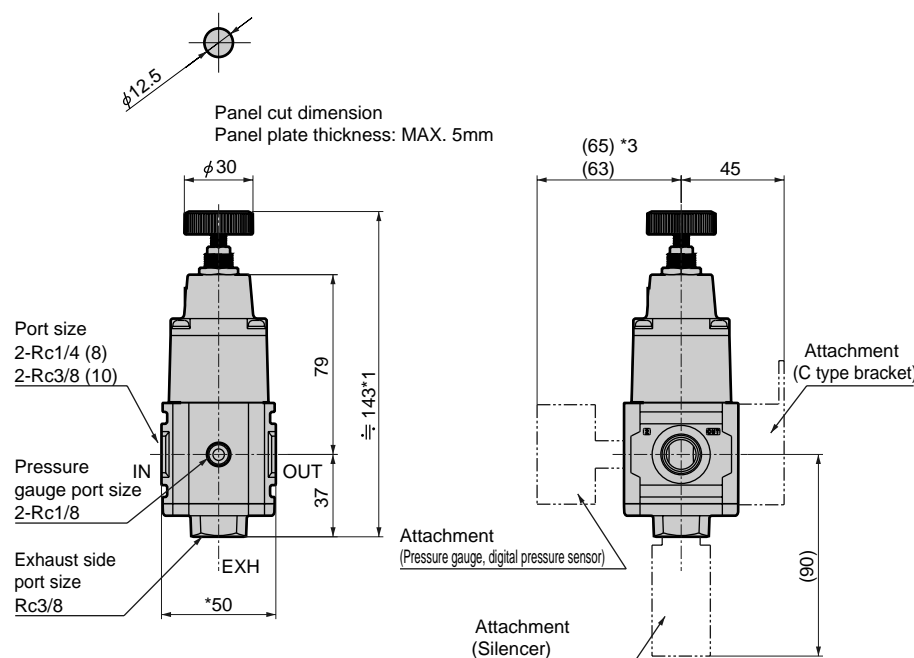

*1: Dimension at setting pressure OMPa
 *2: Pressure gauge, digital pressure sensor, C type bracket and silencer are optionally attached.
 *3: Dimension when digital pressure sensor assembled.

C type bracket

· B220

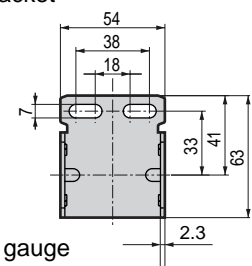

Pressure gauge

· G49D-6-P10

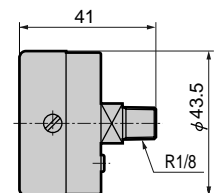

Silencer

· SLW-10A

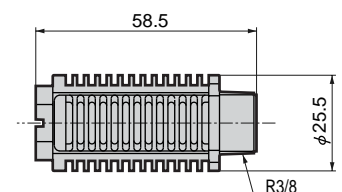

Refrigerating type dryer
 Desiccant type dryer
 High polymer membrane dryer
 Air filter
 Auto. drain / others
 F.R.L. (Module unit)
 F.R.L. (Separate)
 Compact F.R.
 Precise regulator
 F.R.L. (Related products)
 Clean F.R.
 Electro pneumatic regulator
 Air booster
 Speed control valve
 Silencer
 Check valve / others
 Joint / tube
 Vacuum filter
 Vacuum regulator
 Suction plate
 Magnetic spring buffer
 Mechanical pressure SW
 Electronic pressure SW
 Contact / close contact cont. SW
 Air sensor
 Pressure SW for coolant
 Small flow sensor
 Small flow controller
 Flow sensor for air
 Flow sensor for water
 Total air system
 Total air system (Gamma)

Ending

Precision regulator
 F.R.L. unit

Dimensions

● PPX-R10N-6M

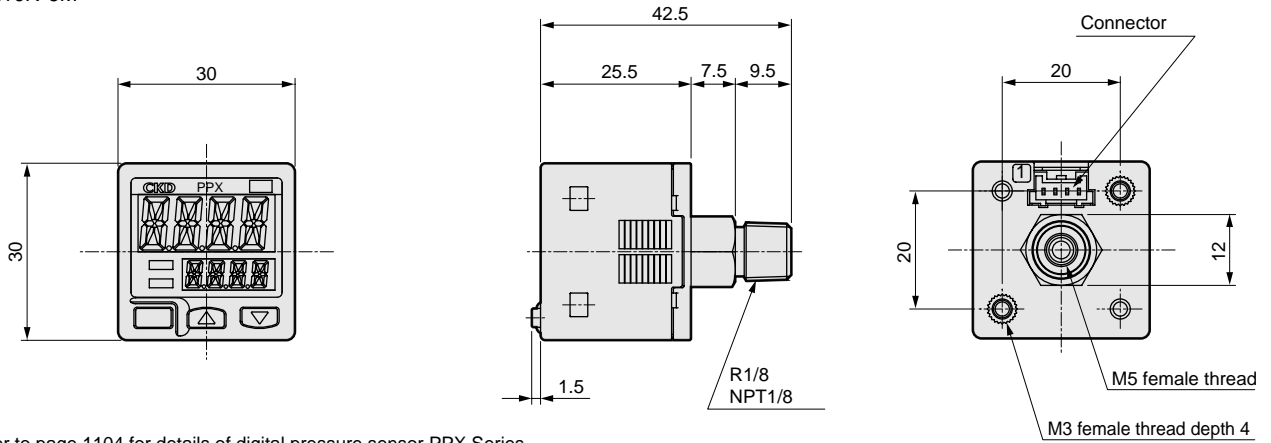

Note: Refer to page 1104 for details of digital pressure sensor PPX Series.

Flow characteristics

● RP2000-10-08

Primary pressure 0.7MPa

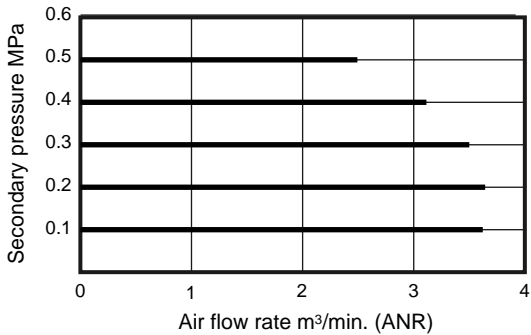

● RP2000-8-08

Primary pressure 0.7MPa

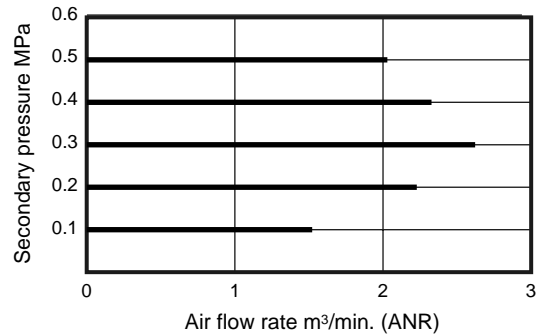

Relief flow characteristics

● RP2000-10-08

Primary pressure 0.7MPa

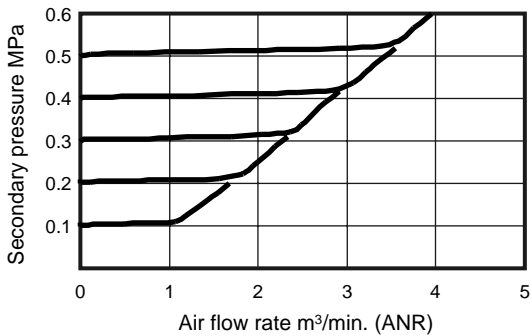

● RP2000-8-08

Primary pressure 0.7MPa

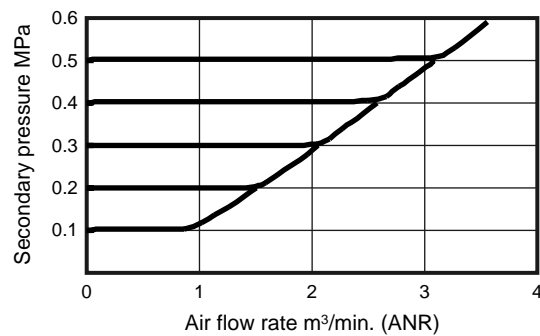

Pressure characteristics

● RP2000-*-08

Secondary flow 0 l/min.

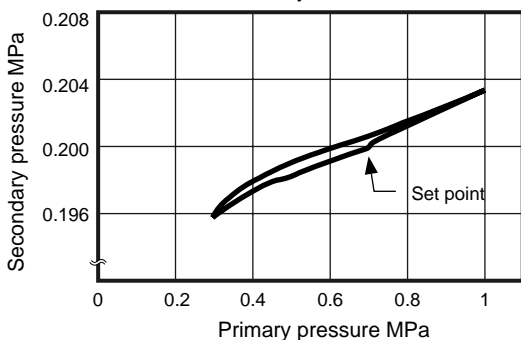

- Refrigerating type dryer
- Desiccant type dryer
- High polymer membrane dryer
- Air filter
- Auto. drain / others
- F.R.L. (Module unit)
- F.R.L. (Separate)
- Compact F.R.
- Precise regulator
- F.R.L. (Related products)
- Clean F.R.
- Electro pneumatic regulator
- Air booster
- Speed control valve
- Silencer
- Check valve / others
- Joint / tube
- Vacuum filter
- Vacuum regulator
- Suction plate
- Magnetic spring buffer
- Mechanical pressure SW
- Electronic pressure SW
- Contact / close contact conf. SW
- Air sensor
- Pressure SW for coolant
- Small flow sensor
- Small flow controller
- Flow sensor for air
- Flow sensor for water
- Total air system
- Total air system (Gamma)
- Ending

Cylinder speed range of RP2000

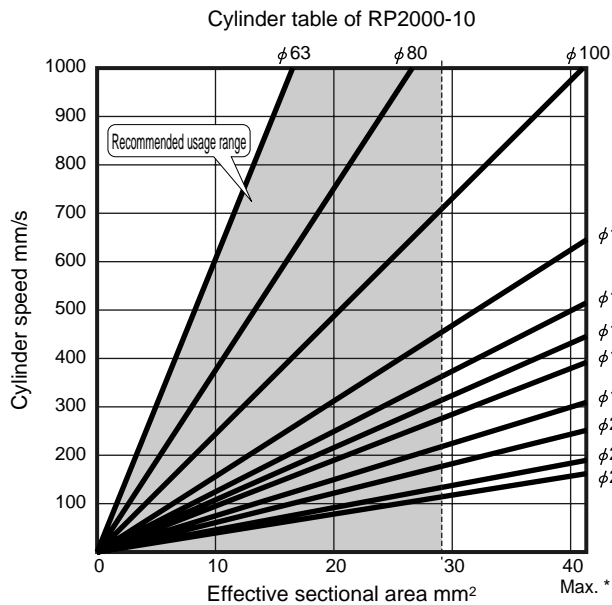

This cylinder table shows available range according to air supply / exhaust flow rate of precision regulator and required consumption flow rate at cylinder PUSH/PULL.

----- Recommended cylinder line
(70% of maximum flow rate is recommended)

* Max. cylinder line
(Cylinder directly installed)

Example of precise pressure control system

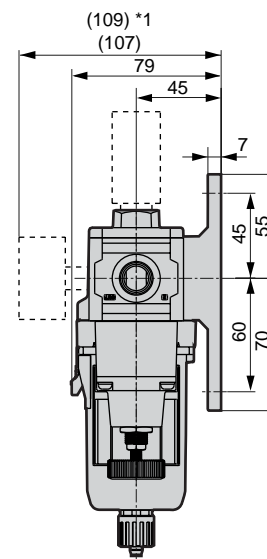
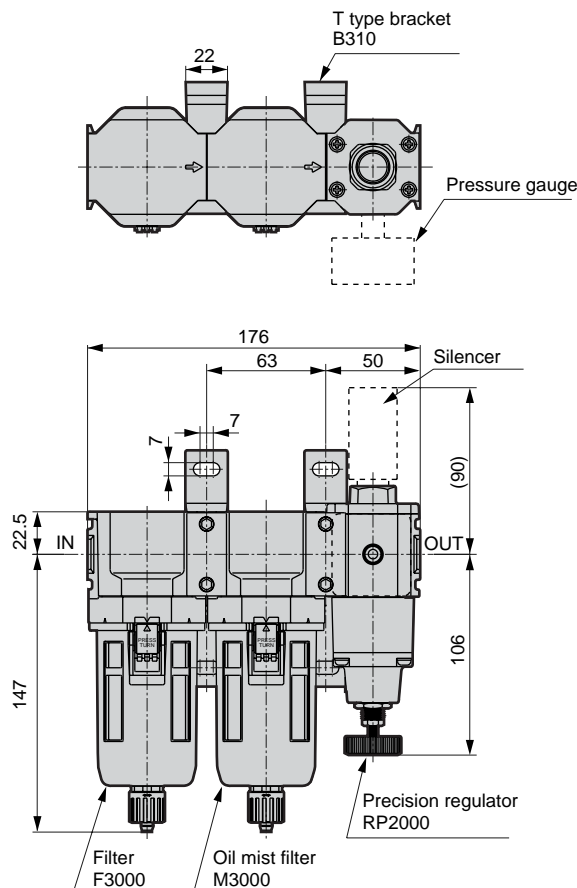

* Dimension when digital pressure sensor assembled.

* Consult with CKD if required for assembly.

Applicable model	Filter	Oil mist filter	Precision regulator	T type bracket set
Model	F3000	M3000	RP2000	B310 (2 pcs.)

- Refrigerating type dryer
- Desiccant type dryer
- High polymer membrane dryer
- Air filter
- Auto. drain / others
- F.R.L. (Module unit)
- F.R.L. (Separate)
- Compact F.R.
- Precise regulator**
- F.R.L. (Related products)
- Clean F.R.
- Electro pneumatic regulator
- Air booster
- Speed control valve
- Silencer
- Check valve / others
- Joint / tube
- Vacuum filter
- Vacuum regulator
- Suction plate
- Magnetic spring buffer
- Mechanical pressure SW
- Electronic pressure SW
- Contact / close contact cont. SW
- Air sensor
- Pressure SW for coolant
- Small flow sensor
- Small flow controller
- Flow sensor for air
- Flow sensor for water
- Total air system
- Total air system (Gamma)

Precision regulator
F.R.L. unit

Refrigerating type dryer
Desiccant type dryer
High polymer membrane dryer
Air filter
Auto. drain / others
F.R.L. (Module unit)
F.R.L. (Separate)
Compact F.R.
Precise regulator
F.R.L. (Related products)
Clean F.R.
Electro pneumatic regulator
Air booster
Speed control valve
Silencer
Check valve / others
Joint / tube
Vacuum filter
Vacuum regulator
Suction plate
Magnetic spring buffer
Mechanical pressure SW
Electronic pressure SW
Contact / close contact conf. SW
Air sensor
Pressure SW for coolant
Small flow sensor
Small flow controller
Flow sensor for air
Flow sensor for water
Total air system
Total air system (Gamma)
Ending

Major applications

■ Liquid discharge control

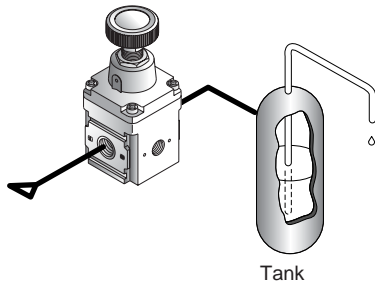

■ Balance

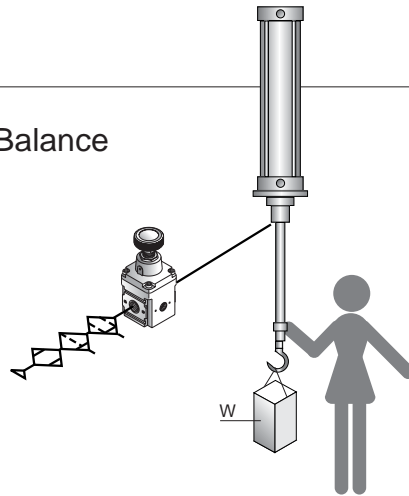

■ Pilot pressure control

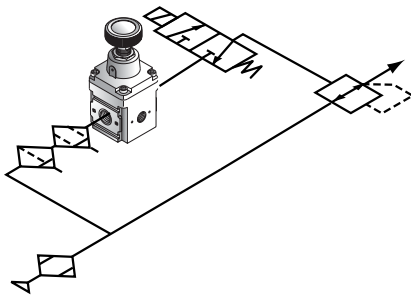

■ Extremely low pressure blow

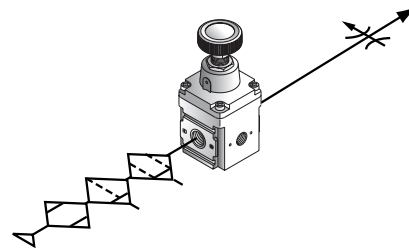

■ Quick pressure adjustment in tank

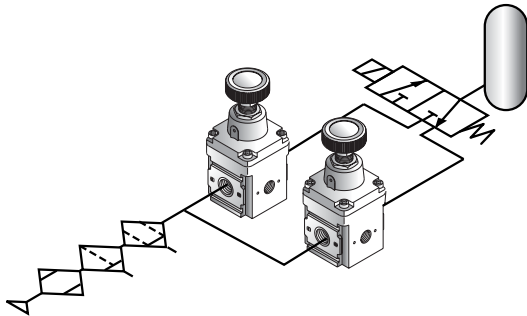

■ Leak test

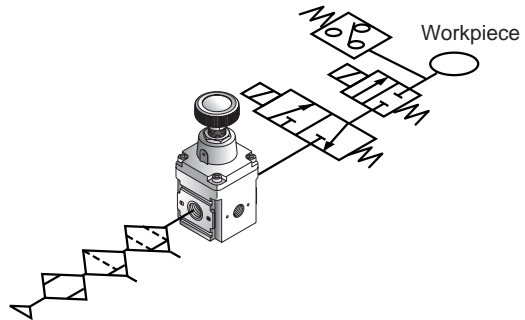

■ Tension control

