

Air unit CXU Series

AIR UNIT CXU SERIES



New

Additional solenoid valves and check valve now available.
More flexibility and less space by combining 2000 Series.

New-Generation Pneumatic Unit

NEW

Flexible combination without piping or problems!

A wide variety of function parts enhances versatile unit combinations. Customized specifications are also available.

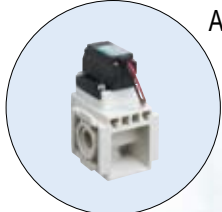

2 port pilot solenoid valve
<Blow valve>

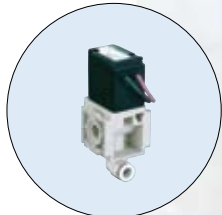

2 port direct acting solenoid valve
<Blow valve>



2 port direct acting solenoid valve
<Blow valve>



2 port pilot operated solenoid valve
<Main ON/OFF valve>

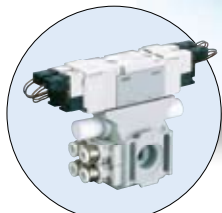

5 port pilot operated valve
<Actuator drive>



CUSTOM AIR UNIT

VALVE UNIT

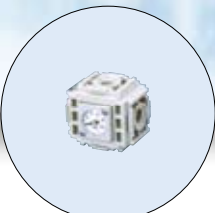

Four direction distributor
<Line branch>

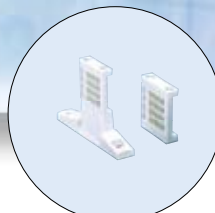

Masking adapter
<Masking of connection section>

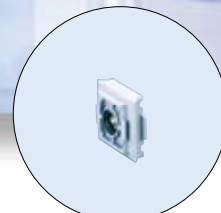

Module transform adapter
<Conversion to other series>

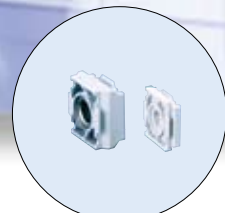

Turn adapter
<90° direction conversion>

PART

NEW



2 port pilot kick solenoid valve
<Main ON/OFF valve>

NEW

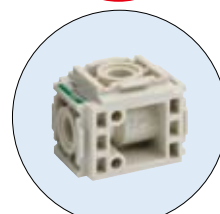

Modular check valve

NEW

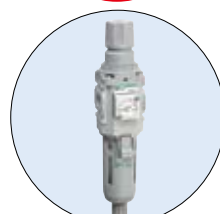

Modular F.R.L.
2000 Series

Air unit

CXU Series

The air unit CXU series modularizes and joins the wide variety of air components indispensable for pneumatic control and actuator drives between filters or regulators and valves. This series dramatically reduces conventional design and piping labor hours.



配管不要・手間要らず

Piping-versatile, space-saving

Bothersome piping design and work have been eliminated. All work is completed by preparing a single unit. Installation space is also reduced with the elimination of piping and tubes. This also makes for a neater appearance. Mounting positions for separate components are eliminated, and errors in mounting dimensions caused when pipes are tightened are solved.

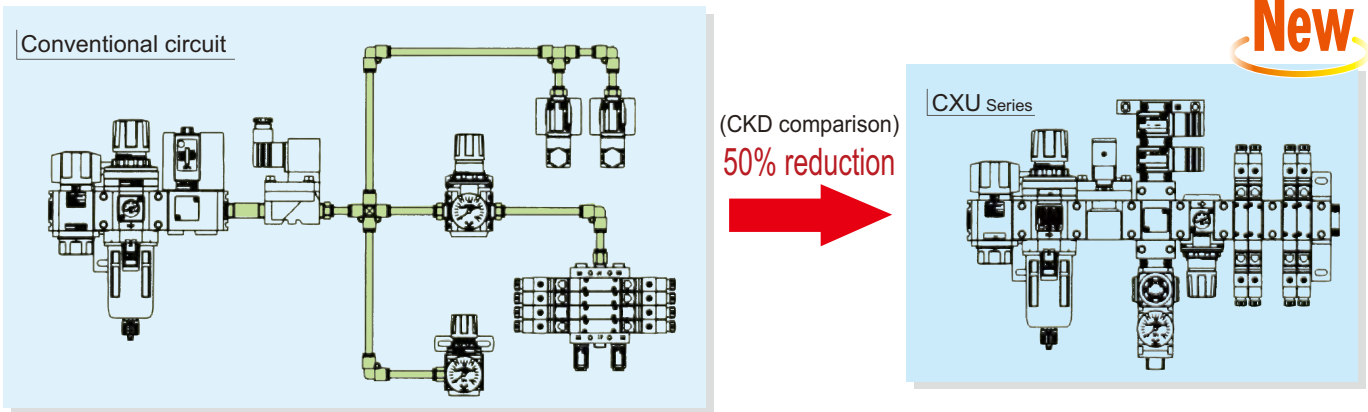

Improved quality

No threading sections, no external leaks! This also prevents foreign materials from entering during piping work.

組合せ自在

Vertical or horizontal

Vertical and horizontal pipes can be arranged versatilely. Solenoid valves can also be connected directly. The simple layout greatly reduces piping design labor hours. (AIR UNIT custom order parts)

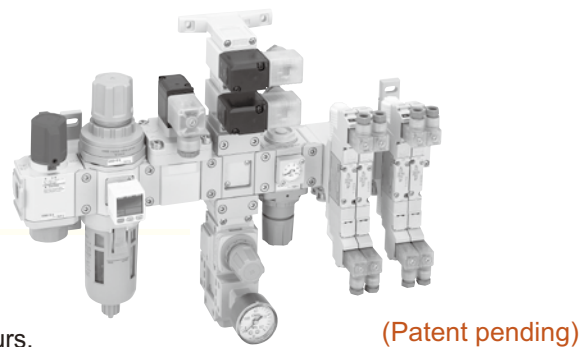

(Patent pending)

Easy change and expansion

Module joining lets air components be changed and expanded freely. Components can be attached and removed from the front face. This also facilitates maintenance.

Example of major applications

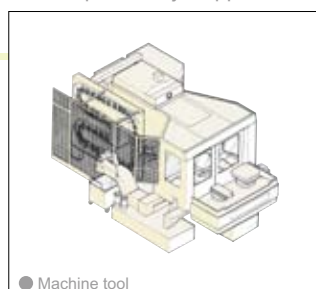

● Machine tool

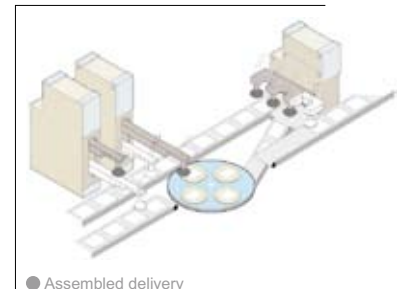

● Assembled delivery



Valve air unit (model no. for manifold)

Model	Model no.	Series			Page
		1000	2000 3000 4000		
2 port direct acting solenoid valve	CXU10-GEXA NEW	●		2	
5 port pilot operated valve	CXU30-M4G2		●	6	

Air unit (model no. for discrete part)

Model	Model no.	Series			Page
		1000	2000 3000 4000		
2 port direct acting solenoid valve	CXU10-EXA NEW	●		14	
	CXU10-FAB3	●		16	
	CXU30-FAB4U		●	18	
2 port pilot kick solenoid valve	CXU30-ADK NEW		●	20	
2 port pilot operated solenoid valve	CXU30-FAD		●	22	
5 port pilot operated valve	CXU30-4G2		●	24	
Contact confirmation switch	GPS2, MGPS2	●		30	
Modular check valve	CXU10-CHV NEW	●		34	
4 directional distributor	CXU10-D4	●		36	
	CXU30-D4		●	36	
Turn adapter	CXU10-TA	●		38	
	CXU30-TA		●	38	
Masking adapter	CXU10-MA	●		39	
Module transform adaptor	CXU13-CA	●		40	

Custom air unit (Model no. for custom combinations)

Model	Model no.	Series		Page
		1000	2000 3000 4000	
CXU10 Series	CXU10-UN-	●		46 to 47
CXU13 Series	CXU13-UN-		●	52 to 53
CXU30 Series	CXU30-UN-		●	48 to 51

Order made air units

Model	Model no.	Series		Page
		1000	2000 3000 4000	
Order made air units	CXUZ-FL	●	●	89

Valve air unit

Air unit component

Custom air unit

Handled as a custom order



Safety precautions

Always read this section before starting use.



When designing and manufacturing a device using CKD products, the manufacturer is obligated to check that device safety mechanism, pneumatic control circuit, or water control circuit and the system operated by electrical control that controls the devices is secured.

It is important to select, use, handle, and maintain the product appropriately to ensure that the CKD product is used safely. Be sure to observe the description given under DANGER, WARNING and CAUTION to assure safety of the equipment. Check that device safety is ensured, and manufacture a safe device.

WARNING

- 1 This product is designed and manufactured as a general industrial machine part.
It must be handled by an operator having sufficient knowledge and experience in handling.
- 2 Use this product in accordance of specifications.
This product must be used within its stated specifications. It must not be modified or machined.
This product is intended for use as a general-purpose industrial device or part. It is not intended for use outdoors or for use under the following conditions or environment.
(Note that this product can be used when CKD is consulted prior to use and the customer consents to CKD product specifications. The customer must provide safety measures to avoid risks in the event of problems.)
 - ① Use for special applications requiring safety including nuclear energy, railroad, aviation, ship, vehicle, medical equipment, equipment or applications coming into contact with beverage or food, amusement equipment, emergency shutoff circuits, press machine, brake circuits, or for safeguard.
 - ② Use for applications where life or assets could be adversely affected, and special safety measures are required.
- 3 Observe corporate standards, regulations, etc., related to the safety of device design and control, etc.
ISO4414, JIS B 8370 (pneumatic system rules)
Principles for pneumatic cylinder selection and use
Including High Pressure Gas Maintenance Law, Occupational Safety and Sanitation Laws, other safety rules, body standards and regulations, etc.
- 4 Do not handle, pipe, or remove devices before confirming safety.
 - ① Inspect and service the machine and devices after confirming safety of the entire system related to this product.
 - ② Note that there may be hot or charged sections even after operation is stopped.
 - ③ When inspecting or servicing the device, turn off the energy source (air supply or water supply), and turn off power to the facility. Discharge any compressed air from the system, and pay enough attention to possible water leakage and leakage of electricity.
 - ④ When starting or restarting a machine or device that incorporates pneumatic components, make sure that the system safety, such as pop-out prevention measures, is secured.
- 5 Observe warnings and cautions on the pages below to prevent accidents.

■ The safety cautions are ranked as "DANGER", "WARNING" and "CAUTION" in this section.

-  **DANGER:** When a dangerous situation may occur if handling is mistaken leading to fatal or serious injuries, or when there is a high degree of emergency to a warning.
-  **WARNING:** When a dangerous situation may occur if handling is mistaken leading to fatal or serious injuries.
-  **CAUTION:** When a dangerous situation may occur if handling is mistaken leading to minor injuries or physical damage.

Even items described under CAUTION may cause serious results.
In any case, important information that must be observed is explained.

Disclaimer

- 1 **Term of warranty**
"Warranty Period" is one (1) year from the first delivery to the customer.
- 2 **Scope of warranty**
In case any defect attributable to CKD is found during the Warranty Period, CKD shall, at its own discretion, repair the defect or replace the relevant product in whole or in part, according to its own judgment.
This Limited Warranty will not apply to:
 - ① Product abuse/misuse contrary to conditions/environment recommended in its catalogs/specifications.
 - ② Failure due to other causes.
 - ③ Use other than original design purposes.
 - ④ Third-party repair/modification
 - ⑤ Failure caused by reason that is unforeseeable with technology put into practical use at the time of delivery
 - ⑥ Failure attributable to force majeure.In no event shall CKD be liable for business interruptions, loss of profits, personal injury, costs of delay or for any other special, indirect, incidental or consequential losses, costs or damages.
- 3 **Compatibility confirmation**
In no event shall CKD be liable for merchantability or fitness for a particular purpose, notwithstanding any disclosure to CKD of the use to which the product is to be put.



Safety precautions

Fluid control components: Warnings, cautions

Refer to the "General purpose valve (No. CB-03-1SA)" for precautions for general-purpose control components. Always read this section before starting use.

Specific precautions 2 port direct acting solenoid valve CXU10-FAB3, CXU30-FAB4U/2 port pilot operated solenoid valve CXU30-FAD, 2 port pilot kick type solenoid valve CXU30-ADK

Design & Selection

1. Design for Safety

⚠ WARNING

- This product can not be used as an emergency shut off valve.

Valves in this catalog are not designed to ensure safety such as emergency shutoff. When using in such a system, provide other measures to ensure safety.

- Take measures to prevent harm to operators or objects should this product fail.

⚠ CAUTION

- Leakage current from other fluid control components
When using a programmable controller, etc., with CR circuits to absorb the surge voltage generated by switching elements, leakage current could pass and adversely affect the operation of the solenoid valve. Keep leakage current to less than the value given in precautions for products in this catalog or values given for products.

- Minimum working pressure difference
The pilot valve must be used at the minimum working pressure difference or higher listed in specifications in this catalog. (CXU30-FAD)

2. Working fluid

⚠ WARNING

- Quality of fluid
Iron rust and dirt, etc., in fluid can cause operation faults or leaks, and lowering product performance. Eliminate such substances.

- Temperature of fluid
Do not use beyond specified temperature range.

3. Working conditions

⚠ WARNING

- Only explosion-proof solenoid valves and air-driven valves can be used in an explosion-proof atmosphere. Explosion proof solenoid valves are not available for an air unit. Select from "General purpose valve" (No.CB-03S-1)

- When using AC voltage, a large noise may be generated, depending on working conditions. Select DC specifications if humming could become an issue.

- Do not use this product in an environment in which corrosive gases could impregnate configuration materials.

- Do not use this product near heat-generating elements or where it may be subject to radiated heat.

- Use the product within the specified ambient temperature range.

- Take appropriate antifreeze measures when using in a cold district.
When insulating the solenoid valve, etc., do not treat the coil.

- Take appropriate safeguards for protective structures listed in catalog specifications.

- Take appropriate safeguards when using this product in places where oil or spatter from welding, etc., could come in contact.

4. Securing space

⚠ CAUTION

- Securing maintenance space
Secure sufficient space for maintenance and inspection.

5. Leakage current

- Leakage current from other fluid control components
When operating the solenoid valve with a programmable controller etc., confirm that the leak current output from the programmable controller is within the following specifications.

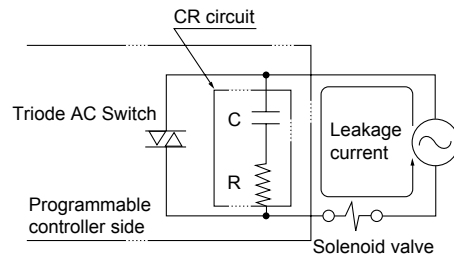

Voltage	AC100V	AC200V	DC12V	DC24V
Model no.				
CXU10-FAB3	6mA or less	3mA or less	1mA or less	2mA or less
CXU30-FAB4U				
CXU30-FAD				
CXU30-ADK	6mA or less	3mA or less	2mA or less	1mA or less

Installation & Adjustment

1. Installation

⚠ CAUTION

- Always thoroughly read the Instruction Manual before installing this product.
- Do not apply external force to the coil section.
- After installing, check for leaks from pipes and wire connections, and check that the product is correctly installed.

2. Piping

⚠ CAUTION

- If the pipe vibrates when the solenoid valve is opened and closed, secure piping.
- The solenoid valve may chatter depending on the circuit. Contact CKD if chattering occurs.
- If the piping cross-section area on the fluid inlet is reduced, the operation may become unstable due to a differential pressure fault during valve operation. For fluid supply piping, the pipe size must match the valve's bore size, and the piping diameter must have no restricted sections. (CXU30-FAD, CXU30-ADK)

3. Wiring

⚠ CAUTION

- Use within the allowable voltage range. Use outside of the allowable voltage range may lead to operation faults or coil damage.
- Provide a circuit breaker, such as a fuse, on the control circuit to protect electrical equipment.
- If electrical circuitry is susceptible to solenoid surges, provide measures such as inserting a surge absorber parallel to the solenoid.
- Use a wire more than 0.5mm² of nominal section area as the reference. Check that no excessive force is applied to leads.
- Use of a switching circuit that does not cause contact chatter will lengthen the life of the solenoid valve and motorized valve.

During Use & Maintenance

1. Maintenance Inspection

⚠ WARNING

- Do not tighten while pressure is applied.
The solenoid valve's coil and actuator will heat up when electricity is passed through them. Depending on the product, directly touching these sections could cause burns.
- Do not touch coils or actuators with hands while power is on or immediately after turning power on. There is a risk of electric shock.
Touching electrical wire connections while power is on could lead to electrical shocks.
- Use within the maximum service pressure and maximum working pressure difference range.
- To ensure that the product is used optimally, regularly inspect the product every six months. This frequency varies with the frequency of use.

⚠ CAUTION

- Do not step the valve, nor put the heavy things on it.
- When using the product with continuous energizing and low frequency, consult with CKD.
- If the product has not been used for more than a month, carry out trial operation.
- Read the instruction manual thoroughly before starting maintenance to ensure correct operation.
- Turn power off and release fluids or pressure before starting maintenance.
- Check that the filter is not clogged.

During Use & Maintenance

2. Assembling & Disassembling

⚠ CAUTION

- When cleaning the product, use a low-polluting cleaning agent such as a neutral detergent. (However, rubber parts must be replaced since it may swell)
- Consult with CKD on questions about consumables, etc.
- The coil assembly mounting screw must be tightened with the following torque for disassembly and assembly.

Model no.	Coil assembly mounting screw
CXU10-FAB3	1.1 to 1.8Nm
CXU30-FAB4U	
CXU30-FAD	
CXU30-ADK	

3. How to connect terminal box

■ DIN terminal box with indicator light (Pg11)

- ① Use the following cabtire cable.
 - Cable outer diameter: $\phi 6$ to $\phi 10$
 - Nominal sectional area: 0.5 to 1.5mm²
- ② Insert a bare crimp terminal for copper wire into the lead wire of the cabtire cable and caulk the terminal. M3 terminal screws are used with the terminal box.
- ③ Tighten screws with the following tightening torque.
 - Setscrew tightening torque ... 0.5Nm
 - Terminal screw tightening torque ... 0.5Nm

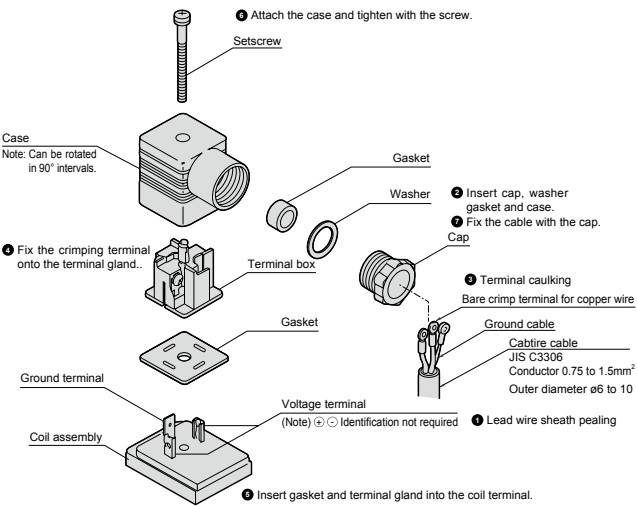

Wire the terminal box following steps ① to ④.

* The orientation of the cable lead out port can be changed by removing the terminal box from the case, rotating it by 90°, then returning the terminal box to the case.

4. Instantaneous leakage phenomenon

- Instantaneous leakage phenomenon
When using the 2 port pilot operated solenoid valve, sudden application of pressure (e.g. starting up compressor) could momentarily open a closed valve and cause fluid to leak. Exercise caution.
(CXU30-FAD, CXU30-ADK)



Safety precautions

Fluid control components: Warnings, cautions

Always read this section before starting use.

Refer to the "General Purpose Valves (Catalog No. CB-03-1S)" for details on precautions for general purpose valves.

Specific precautions: 2 port pilot operated solenoid valve CXU-EXA Series

Design & Selection

1. Confirmation of specifications

⚠ WARNING

- Use within the product's specific specification range. Use with pressure or temperature exceeding the specification range may result in damage or operation faults. Refer to specifications. Contact CKD when using for fluids other than compressed air.

■ Working fluid

Active gases are not applicable.
Consult with our sales office when using it.

2. Safe design

⚠ WARNING

- Take measures to prevent harm to operators and product failure.

⚠ CAUTION

- Check leakage current to prevent other fluid control components from malfunctioning due to leakage current.
 - When using a programmable controller, etc., the solenoid valve could malfunction because of leakage current. The value affected by leakage current differs with the solenoid valve.

■ DIN terminal box connection type protection property symbol (IPX5)

IP X5 (IEC 60529 (IEC 529: 1989-11)) standards are applied to the test. Avoid use in condition which water or coolant could directly contact the valve.

Explanation of protection property symbols and examination method of IPX5

● Protective structure

Note: IP-X5 is a test based on the following standard

■ IEC (International Electrotechnical Commission) Standards

(IEC60529 [IEC529: 1989-11])

IP - □ □

Protection property symbols (International Protection)

1st characteristic number (protective class against external solids)

2nd characteristic number (protective class against entry of water)

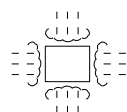
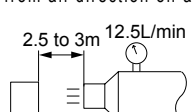
Grade	Degree of protection	Overview of test method (fresh water is used.)
5	Protection against powerful jets 	Water projected in powerful jets shall not enter products in adverse amounts. 

Spray nozzle inner diameter: ø6.3mm

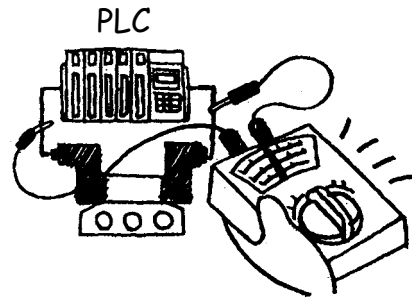

100VAC	2.0mA or less
24VAC	1.8mA or less

■ Follow the precautions below when using nylon tubes or urethane tubes.

- Use flame resistant tubes where spatter could scatter.
- When using the standard push-in joint on the spiral tube, fix the base of the tube with a hose band. The tube will rotate and holding force will drop if not fixed.

3. Working environment

■ Use clean air.

- The product could break or malfunction if used with compressed air containing chemicals, synthetic oils containing organic solvents, salt, or corrosive gases, etc.
- Maintain the ozone concentration in the compressed air below 0.1ppm. Increase in ozone concentration will result in deficiencies such as malfunctions and leakage.

4. Durability

⚠ WARNING

- Use in continuous energizing could deteriorate the solenoid valve's performance. Contact CKD for such applications.

5. Pneumatic pressure source

⚠ CAUTION

- Install the air filter just before the circuit using the pneumatic component.

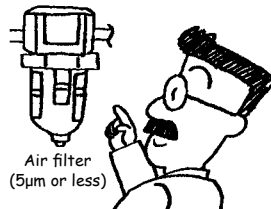

- Do not supply other than compressed air.
- Use clean compressed air that does not contain corrosive gases.
- Use dry compressed air that does not cause condensation in piping.

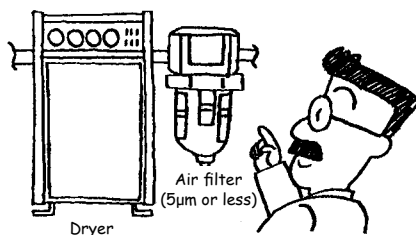

- Drainage will remove lubricant, and cause lubrication faults.
- Drain will enter the air path in pneumatic components to block the flow path instantaneously, causing malfunction.
- Drainage could cause rust, causing the pneumatic device to fail.
- Use compressed air that does not contain oxidized oil, tar, carbon, etc., from the air compressor.
 - If oxidized oil, tar, or carbon enter the air compressor and solidifies, resistance at the sliding section will increase, and could lead to operation faults.
- Use compressed air that does not contain solid foreign matter.
 - Solid foreign matter in compressed air could enter the air compressor and cause wear, sticking, or leakage at the sliding section.

6. Surge suppressor

⚠ CAUTION

- The surge suppressor enclosed with the solenoid valve is to protect the output contact for that solenoid valve's drive. There is no significant protection for the other peripheral devices, and devices could be damaged or malfunction by the surge. Surge generated by other devices could be absorbed, resulting in damage or accidents such as burning. Note the following points.

- The surge suppressor functions to limit a solenoid valve surge voltage, which can reach several hundred V, to a low voltage level that the output contact can withstand. This may be insufficient for the output circuit, however, and could result in damage or malfunction. Check that the surge suppressor is adequate for the surge voltage limit of the solenoid valve used, the output device withstand voltage, and circuit configuration, and the degree of return delay time. Provide separate surge measures if necessary. Reverse voltage surge generated at OFF is suppressed to the following levels by the solenoid valve with surge suppressor of this product.

Rated voltage	Reverse voltage value when power turned OFF
24VDC	Approx. 47V

- When using the NPN output unit, a surge voltage equivalent to the voltage above plus the power voltage surge could be applied. Provide contact protection circuit.

(example of output transistor protective circuit installation 1)

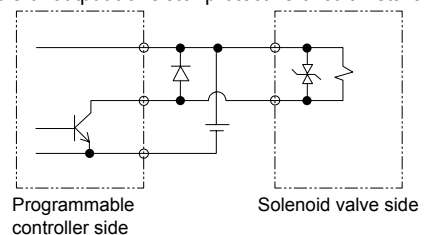

(example of output transistor protective circuit installation 2)

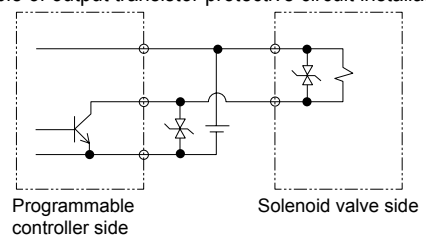

- If another device or solenoid valve is connected in parallel to the solenoid valve, the inverse voltage surge generated when the valve is OFF would apply to those devices. Even when using the solenoid valve for the surge suppressor for 24 VDC, surge voltage may reach minus several ten V depending on the model. This reverse polarity voltage could damage or cause other devices connected in parallel to malfunction. Avoid parallel connection with a device having weak reverse polarity voltage. (Example: LED indicator.) When driving several solenoid valves in parallel, the surge from other solenoid valves could enter the surge suppressor of one solenoid valve with a surge suppressor. Depending on the current value, that surge suppressor could burn. When driving several solenoid valves with surge suppressors in parallel, surge current could concentrate at the surge suppressor with the lowest limit voltage and cause similar burning. Even if the solenoid valve is the same, surge suppressor limit voltage is inconsistent and in the worst case could result in burning. Avoid driving several solenoid valves in parallel.

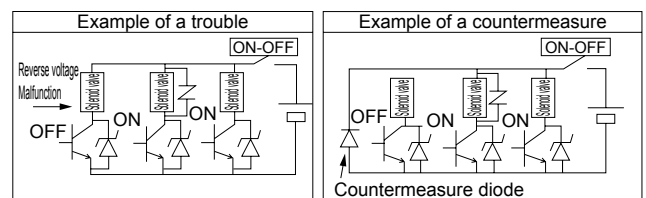

- The surge suppressor incorporated in the solenoid valve will often short-circuit if damaged by excessive voltage or current the other solenoid valves. After such damage, large current flows when output is turned on, and in the worst case, the output circuit or solenoid valve is damaged or fires start. Do not leave the solenoid valve energized in a faulty state. Provide an overcurrent protection circuit on the power or drive circuit, or use a power supply with overcurrent protection so that no large current flows continuously.

7. 100VAC specifications

⚠ CAUTION

- For 100 VAC, all wave rectified circuit is incorporated.

When using an SSR to turn the solenoid valve on and off, a solenoid valve reset fault may occur depending on the SSR.

Select the SSR appropriately. Consult with the relay or PLC manufacturer for details.)

Installation & Adjustment

1. Installation

⚠ WARNING

- Avoid washing with water or solvents or painting after installation.
 - Resin parts could be damaged.
- Make sure that the joint and tube are not twisted or pulled, and that moment load is not applied.
- Check that tubing is not worn or damaged.
 - Tubing could be crushed, ruptured, or dislocated.

2. Confirmation before operation

⚠ CAUTION

- When supplying compressed air for the first time after connecting pipes, do not apply high pressure suddenly.
 - Tube may come off and fly out, causing an accident.
- When supplying compressed air for the first time after connecting piping, confirm that no air is leaking from any pipe connections.
 - Apply a leakage detection agent on pipe connections with a brush, and check for air leaks.

3. Piping

- Connect piping so that connections are not dislocated by system movement, vibration, or tension.
 - When using the push in joint, cut the tube at right angles using a dedicated tool.
 - Confirm that the tube has been inserted properly, and make sure that there is no tension during use. The tube could be dislocated or damaged if there is any tension.
- Make sure that the joint and tube are not twisted or pulled, and that moment load is not applied.
- Use the designated tube.
 - Mount an insert sleeve especially when using extremely flexible urethane tubing.

- Securely insert the tube to the tube end, and make sure that the tube cannot be pulled off.

- Cut the tube at right angles using a dedicated cutting tool.

4. Lead wire wiring

⚠ CAUTION

- Wire in a suitable method for the lead wire.

The used lead wires are as follows.

Electric connection symbol	Descriptions	Conductor size	Conductor cross-section areas	Isolator outer diameter	Sheath outer diameter
Blank	Grommet lead wire	AWG#24	0.22 equivalent	1.42	-

5. DIN terminal box

⚠ WARNING

- Turn power OFF before disassembling or assembling the terminal box. There is a risk of electric shock.

⚠ CAUTION

■ Disassembly

- Loosen the screw ①, and pull the cover ② in the direction of screw ①. The connector will come off the coil assembly ⑩.
- Pull the screw ① out of the cover ②.
- There is a notch ⑨ (next to GDSN mark) on the bottom of the terminal block ③. Insert a small flat-tip screwdriver between the housing ② and terminal block ③, and twist it. The terminal block ③ will come off the cover ②. (Refer to Fig. 1.) Remove the terminal box without applying excessive force. may result in damage
- Remove the cable gland ④, and remove the washer ⑤ and rubber packing ⑥.

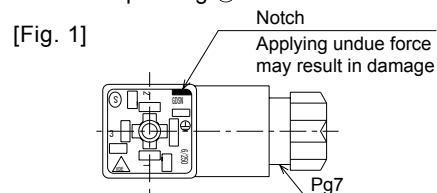

Exploded diagram

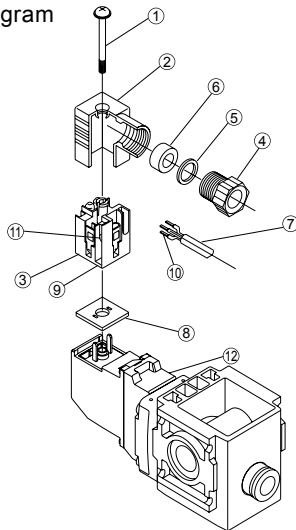

■ Wiring

● Wiring preparation

- Applicable dimensions for cable ⑦ are VCTF2 (3 core (φ3.5 to 7) specified in JISC3306.
- Strip 10mm of the cable's lead sheath.
- Either twisted wires or single conductors are connected.
- When using twisted wires, avoid connecting soldered wires.
- When using a crimping sleeve ⑩ on the end of the twisted wire, use the Japan Weidmuller H0.5/6 (0.3 to 0.5 mm²), H0.75/6 (0.75 mm²) or another equivalent product. The crimping sleeve must be prepared by the user. The crimping sleeve must be prepared by the user.

● Wiring

- Pass the cable gland ④, washer ⑤ and rubber packing ⑥ in order through the cable ⑦, and insert into cover ②.
- Connect to terminal 1 and 2. There is no polarity. There is no polarity.
- Recommended tightening torque is 0.2 to 0.25N·m.

■ Assembly

- Set the wired terminal gland ③ on cover ②
(Press in until it clicks.)

* The terminal block can be set in four directions.

- Set the rubber packing ⑥ and washer ⑤ in order into the cover ② cable lead-in port, and then securely tighten the cable gland ④.

Remarks: Reference tightening torque of cable gland is 1.0 to 1.5N·m.

Check that the cable cannot be pulled out.

- Set the gasket ⑧ between the bottom of the terminal block ③ and the coil assembly ⑫ plug, and insert the connector.

Insert the screw ① from the top of the cover ② and tighten.
Remarks: Recommended tightening torque of a screw is 0.2 to 0.25 N·m.

[Fig. 2]

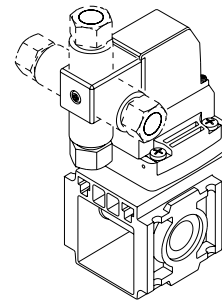

During Use & Maintenance

1. Common

▲ CAUTION

- Energizing for a long time could impair solenoid valve performance. Similar caution is required in the following use.

- During intermittent energizing, when the energized time is longer than the non-energized time.
- During intermittent energizing which one energizing session exceeds 30min.

Consider heat dissipating measures at installation. Consult with CKD when energizing this device continuously.

- Instantaneous leakage phenomenon

When using the 2 port pilot operated solenoid valve, sudden application of pressure (e.g. starting up compressor) could momentarily open a closed valve and cause fluid to leak.

- Disassembly

Do not disassemble this valve.

Disassembling this valve may drop the valve performance.

- Do not touch coils or actuators with hands or otherwise while power is on or immediately after turning power on. The solenoid valve's coil and actuator will heat up when electricity is passed through them.

- Differential pressure

Keep the differential pressure with the valve open above 0.01MPa in the following situations.

- If a restriction, such as a nozzle is included to the secondary side.
- When valves are simultaneously opened in a state where multiple solenoid valves are piped (modular connection) in parallel.
(differential pressure will become difficult to generate between the primary and secondary, due to the drop in source pressure)

- Do not apply tension to the coil section lead wire during installation.

- Hold the product body when carrying the product.
(Do not hold onto the lead wire)

- When the regulator and solenoid valve are directly connected, the parts could mutually vibrate causing resonance and chattering.

- If the piping cross-section area on the fluid inlet is reduced, the operation may become unstable due to a differential pressure fault during valve operation. Use a pipe that matches the port size on the supply side.

- Depending on the working conditions, the operation of the solenoid valve may become unstable if left unused for a long period.
Always have a trial run before using.



Safety precautions

Always read this section before starting use.

Refer to Pneumatic valves Catalog No. CB-023SA for the general valves.

Specific precautions: 5 port pilot operated valve CXU30-4G2 Series

Design & Selection

1. Surge suppressor

CAUTION

■ The surge suppressor enclosed with the solenoid valve is to protect the output contact for that solenoid valve's drive. There is no significant protection for the other peripheral devices, and devices could be damaged or malfunction by the surge. Surge generated by other devices could be absorbed, resulting in damage or accidents such as burning. Note the following points.

- The surge suppressor limits solenoid valve surge voltage, which can reach several hundred volts, to a lower voltage level withstandable by the output contact. This may be insufficient for the output circuit, however, and could result in damage or malfunction. Check that the surge suppressor is adequate for the surge voltage limit of the solenoid valve used, the output device withstand voltage, and circuit configuration, and the degree of return delay time. Provide separate surge measures if necessary. The 4G Series solenoid valve surge suppressor suppresses reverse voltage surge generated at OFF as shown in the following table.

Rated voltage	Reverse voltage value when power turned OFF
24VDC	Approx. 47V

- When using the NPN output unit, a surge voltage equivalent to the voltage above plus the power voltage surge could be applied. Provide contact protection circuit.

(Example of output transistor protective circuit installation 1)

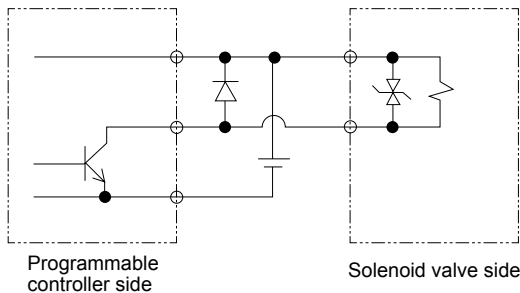

(Example of output transistor protective circuit installation 2)

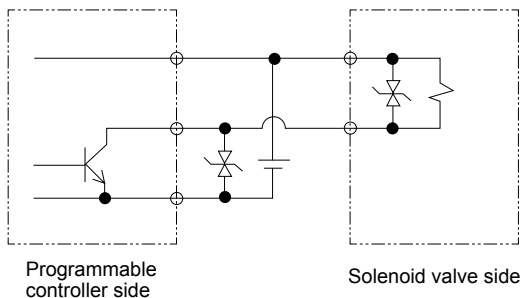

- If another device or solenoid valve is connected in parallel to the solenoid valve, reverse voltage surge generated when the solenoid valve is off is applied to these devices. Even when using the solenoid valve for the surge suppressor for 24 VDC, surge voltage may reach minus several ten V depending on the model. This reverse polarity voltage could damage or cause other devices connected in parallel to malfunction. Avoid parallel connection with a device having weak reverse polarity voltage. (Example: LED indicator.) When driving several solenoid valves in parallel, the surge from other solenoid valves could enter the surge suppressor of one solenoid valve with a surge suppressor. Depending on the current value, that surge suppressor could burn. When driving several solenoid valves with surge suppressors in parallel, surge current could concentrate at the surge suppressor with the lowest limit voltage and cause similar burning. Even if the solenoid valve is the same, surge suppressor limit voltage is inconsistent and in the worst case could result in burning. Avoid driving several solenoid valves in parallel.
- The surge suppressor incorporated in the solenoid valve often short-circuits if damaged by overvoltage or overcurrent from a source other than the solenoid valve. After such damage, large current flows when output is turned on, and in the worst case, the output circuit or solenoid valve is damaged or fires start. Do not leave the solenoid valve energized in a faulty state. Provide an overcurrent protection circuit on the power or drive circuit, or use a power supply with overcurrent protection so that no large current flows continuously.

2. 100VAC specifications

CAUTION

- For 100 VAC, all wave rectified circuit is incorporated. When using an SSR to turn the solenoid valve on and off, a solenoid valve reset fault may occur depending on the SSR. Select the SSR appropriately. Consult with the relay or PLC manufacturer for details.)

Installation & Adjustment

1. Lead wire wiring

⚠ CAUTION

- Lead standards differ with the type of wire connection. Connect wires appropriately.

Electric connection symbol	Descriptions	Conductor size	Conductor cross-section areas	Isolator outer diameter
E□	E-connector with lead wire	AWG#26	0.13 equivalent	1.35

When connecting wires, check that leads do not apply tension to the solenoid valve coil.

2. How to use E-connector

⚠ CAUTION

- The E-connector is a top/side common connector to which the sockets can be connected to either the top or side directions. The socket assembly is enclosed with the valve. Select the connection direction based on installation.

■ How to mount or dismount socket

- When installing the socket, hold the lever and socket with your fingers and insert straight into the square window on the connector. Align the lever with the groove on the connector and lock. When installing from the top, face the socket so that the lever is in front. When installing from the side, face the socket so that the lever is on the top.
- When pulling the socket out, press down on the lever to release jaws from the groove, then pull straight out.

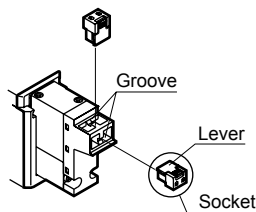

■ How to connect lead wire

- Strip 3 mm of the lead end, arrange the ends of the core wires and insert them into the contact terminal. Crimp both the sheath and wire, and check that 0 to 0.5 mm of the core wire is visible.
- After crimping, turn the contact terminal as shown below, and insert into the square window on the socket. The terminal locks when it is inserted to the end. After insertion, tug lightly on the terminal to check that it is locked.

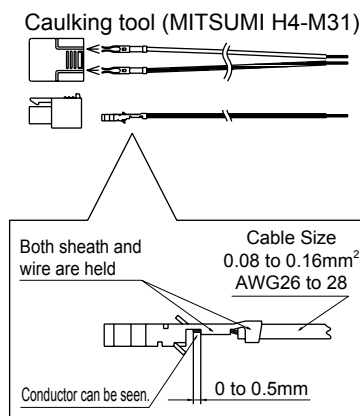

3. DIN terminal box

⚠ WARNING

- Turn power OFF before disassembling or assembling the terminal box. There is a risk of electric shock.

⚠ CAUTION

■ Disassembly

- Loosen the screw ①, and pull the cover ② in the direction of screw ①. The connector will come off the coil assembly ⑫.
- Pull the screw ① out of the cover ②.
- There is a notch ⑨ (next to GDSN mark) on the bottom of the terminal block ③. Insert a small flat-tip screwdriver between the housing ② and terminal block ③, and twist it. The terminal block ③ will come off the cover ②. (Refer to Fig. 1.) Remove the terminal box without applying excessive force. may result in damage
- Remove the cable gland ④, and remove the washer ⑤ and rubber packing ⑥.

[Fig. 1]

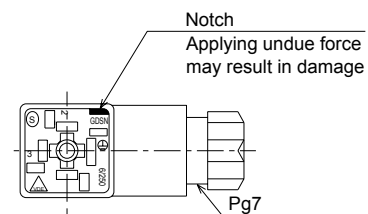

Exploded diagram

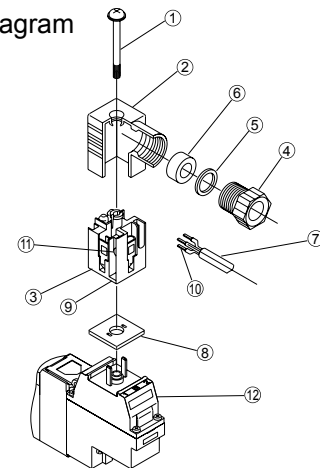

■ Wiring

● Wiring preparation

- Applicable dimensions for cable ⑦ are VCTF2 (3) core (ø3.5 to 7) specified in JISC3306.
- Strip 10mm of the cable's lead sheath.
- Either twisted wires or single conductors are connected.
- When using twisted wires, avoid connecting soldered wires.
- When using a crimping sleeve ⑩ on the end of the twisted wire, use the Japan Weidmuller H0.5/6 (0.3 to 0.5 mm²), H0.75/6 (0.75 mm²) or another equivalent product. The crimping sleeve must be prepared by the user. The crimping sleeve must be prepared by the user.

● Wiring

- Pass the cable gland ④, washer ⑤ and rubber packing ⑥ in order through the cable ⑦, and insert into cover ②.
- Connect to terminal 1 and 2. There is no polarity. There is no polarity.
- Recommended tightening torque is 0.2 to 0.25N·m.

Installation & Adjustment

■ Assembly

- Set the wired terminal gland ③ on cover ② (Press in until it clicks.)

The terminal block can be set in four directions.

- Set the rubber packing ⑥ and washer ⑤ in order into the cover ② cable lead-in port, and then securely tighten the cable gland ④.

Remarks: Reference tightening torque of cable gland is 1.0 to 1.5N·m.

Check that the cable cannot be pulled out.

- Set the gasket ⑧ between the bottom of the terminal block ③ and the coil assembly ⑫ plug, and insert the connector. Insert the screw ① from the top of the cover ② and tighten.

Remarks: Recommended tightening torque of a screw is 0.2 to 0.25 N·m.

[Fig. 2]

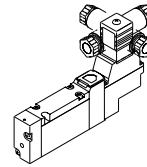

4. Installation

- Make sure that the joint and tube are not twisted or pulled, and that moment load is not applied.

During Use & Maintenance

1. Common

⚠ CAUTION

- Energizing for a long time could impair solenoid valve performance. Similar caution is required in the following use.

- During intermittent energizing, when the energized time is longer than the non-energized time.
- During intermittent energizing which one energizing session exceeds 30min.

Consider heat dissipating measures at installation.

Consult with CKD when energizing this device continuously.

2. Manual override

⚠ WARNING

- CXU30-4G2 series is an internal pilot operated solenoid valve. If air is not supplied to the P port, the main valve will not change even if the manual override is operated.

- A protective cover of manual override is provided as standard. The manual override protective cover is closed when the valve is shipped to protect manual override, which cannot be seen when delivered. Open the protective cover and operate the manual override.

The protective cover will not close unless the manual override is unlocked.

- Manual override is used for both non-locking and locking. The lock is applied by pressing down and turning manual override. When locking, press down and turn. If manual override is turned without being pressed down, it could be damaged or air could leak.

- How to open and close protective cover of manual override

Do not excessively force the manual protective cover when opening and closing it. Excessive force could cause faults. (less than 5N)

CXU30-4G2 Series

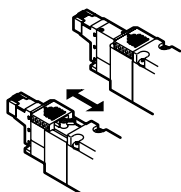

Slide type

CXU30-4G2 Series
DIN terminal box

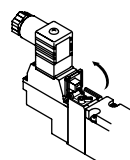

Turn type

- How to operate manual override

- Push/non-locking operation

Push in the direction of the arrow until it stops.

Manual override is unlocked when released.

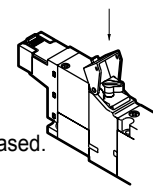

- Push/locking operation

Push manual override and turn 90° in the direction of the arrow.

Manual override is not unlocked even when released.

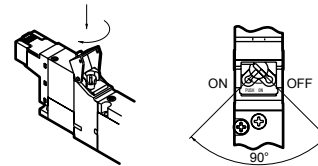

- When conducting manual operations, make sure that there are no people near the moving cylinder.

3. How to replace coil

⚠ WARNING

- E type connector coil assembly

Replace the coil by removing the set screw shown below. Loosening the other screws could cause operation faults. When installing, check that the gasket is installed on the coil side, and note tightening torque. Improper installation could result in air leaks or operation faults.

- DIN terminal box coil assembly

Replace the coil assembly by removing the set screw shown below. Loosening the other screws could cause operation faults. When installing, check that the gasket is installed on the coil assembly side, and note tightening torque. Improper installation could result in air leaks or operation faults.

The grommet lead, E-connector specification and DIN terminal box specification coil assembly cannot be replaced.

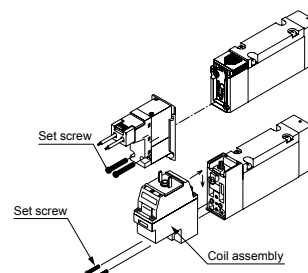



Pneumatic components (F.R.L. unit (modular design))

Safety precautions

Always read this section before starting use.

Refer to "Pneumatic, vacuum and auxiliary components CB-024SA".

Specific precautions: F.R.L. (modular design)

Design & Selection

1. Common

⚠ WARNING

- This product is for industrial use only. Must not be used in components or circuits for medical equipment or components that involve human lives.
- Air filter, lubricator plastic bowl, lubricator' drip window, and pressure gauge lens
Material is polycarbonate. Do not use in the atmosphere with synthetic oil, organic solvent, chemical materials, coolant, screw locking adhesive, liquid soap, hot water, etc., or possible exposure to these substances.
Refer to page 16 for details on bowl chemical resistance.

- Piping load torque
Check that the piping load or torque is not applied to the body or piping sections.

Series	1000	2000	3000	4000
Max. torque N·m	10	10	50	50

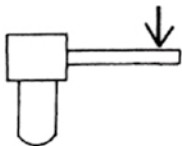

With the 1000-W Series, application of a torque of 20N·m or more on piping could damage piping. Use within the specified torque, even when using the piping adapter.

⚠ CAUTION

- Large drainage
Install the air dryer and drain separator before the air filter.
If there is a large drainage from the compressor. Hot and highly humid air could shorten the device life or result in corrosion.
- Ultra dry air
Rubber parts for the regulator could deteriorate quickly, so use of a fluorine rubber valve assembly is recommended. Consult with CKD for more information.
- Water lubricated compressor circuit
Take measures to prevent chlorine-based substances from entering the compressed air.
- Use the automatic drain under the working conditions below. Failure to observe these conditions could result in malfunction.
 - N.O. type automatic drain (exhaust without pressurized): F
 - Use a compressor with a capacity of 0.75 kW {90l/min [ANR]} or more.
 - Set the working pressure to 0.1 MPa or more. (Initially generated drainage and air are purged until pressure reaches 0.1 MPa.)
 - N.C. type automatic drain (exhaust without pressurized): F1
 - Can be used with compressor with 0.75kw or less.
 - Set the working pressure to 0.15 MPa or more.
- 1000 Series NC automatic drain
 - The working flow must be less than the maximum working flow.
 - In places with high vibration, such as where the compressor is installed, air could leak from the drain port when the float vibrates. Avoid this use.
 - Do not let the drain overflow as it may lead to malfunctioning.

2. Regulator, filter with regulator

⚠ WARNING

- Install a safety device where an output pressure exceeding the regulator's set pressure value could result in damage or faulty operation of secondary side devices.
- The regulator cannot process residual pressure (remove secondary pressure) when primary pressure is released. Use a regulator with a check valve when residual pressure must be processed.
- In some cases, the regulator cannot be used for secondary side sealing circuits or balance circuits. Consult with CKD for these types of applications.

⚠ CAUTION

- Set the regulator's secondary pressure to 85% or less that of the primary side. The pressure could drop further.
- When using regulators in parallel as shown below, do not use the OUT side as a closed circuit. If a closed circuit is required, set a check valve at the regulator's OUT side.

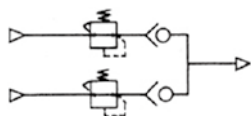

3. Lubricator

⚠ WARNING

- Lubricator
Consult with CKD for using lubrication with an air motor or bearings. Also consult with CKD when using this unit at a high frequency such as in a press machine.

⚠ CAUTION

- If the working air rate is low for the lubricator, oil may not drip.
Check the minimum air rate required for dripping oil.

4. Pressure switch

⚠ CAUTION

- When using a digital pressure sensor PPX or compact pressure switch PPD, avoid using it as a set with the lubricator. The switch is not a drip-proof structure, so operation could be disabled if the lubricating oil comes in contact with it.

5. Shut-off valve

⚠ WARNING

- Precautions for shut-off valve
 - The EXH port is dedicated for installation of the silencer. Tighten with a torque of 3 N·m or less -- as far as is tightened manually.
Avoid piping that applies piping load or torque, etc., to the EXH port.
 - If exhaust is incomplete because of air quality, manually discharge air by operating the knob (turn and raise).

6. Modular check valve

- This valve can not be used as a stop valve that has no leakage. Due to its structure, a few leakage will occur.

Installation & Adjustment

1. Common

CAUTION

- Avoid installing this product where it is subject to direct sunlight.

- Flush and clean pipes before use.
Dirt or foreign materials in piping will lower product performance.

- Check that foreign materials do not enter when tightening pipes or joints.
When screwing in piping or joints, check that swarf from piping threads or sealing agent does not get inside. Dirt or foreign materials in piping will lower product performance.

- How to use the F.R.L. correctly
 - 1 Set the regulator pressure setting to increase. After setting pressure, lock the handle. Check primary pressure carefully before setting pressure.
 - 2 Check the arrow indicating the air inlet before connection. Reverse connection causes malfunctions.
 - 3 Install the air filter and lubricator vertically with the bowl facing downward. Failure to do so could lead to disconnection or malfunction.
 - 4 Use of the automatic drain where vibration is present could cause faults and malfunctions.

- Pipe the automatic drain in the following conditions. Otherwise, malfunctioning may occur.
Use a drain discharge pipe with $\phi 5.7$ or larger size. Keep the pipe length within 5 m, and avoid an upward slope.
Do not pipe in a manner which will apply lateral load to the bowl.
Fix the hexagon side of the cock before screwing the joint, etc., into the Rc1/8 female screw.

■ Piping screw-in torque

Make sure that excessive torque is not applied on the body and piping when piping.

Series	1000	2000	3000	4000
Max. torque N·m	15	30	30	30

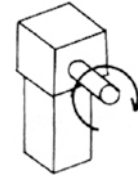

■ Drain piping

- Confirm that the drain cock is closed before inserting the tube. The drain piping for the plastic bowl has a barbed nipple, and can be directly installed. However, confirm that the drain cock is closed before inserting the tube.

■ Drain cock tightening torque

- The max. tightening torque of the drain cock for the plastic bowl is as follows.
 - 1000 Series: 0.1N·m
 - Others: 0.5N·m

■ Drain piping of metal bowl with automatic drain

- Fix the cock's hexagonal face before screwing the joint, etc., into the drain port's female threads. When using the metal bowl with automatic drain, if the drain is piped with a tightening joint, manual operation is not possible.

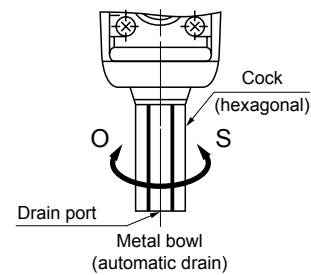

2. Regulator, filter with regulator

⚠ CAUTION

■ Regulator, filter with regulator

- Lightly tighten (0.6 N·m or less) mounting screws for embedded pressure gauge G401-W-OP, G401-W, and gauge plug.
- When installing the pressure gauge with a safety mark on the gauge plug, or when installing a general screw-in pressure gauge, tighten with a torque of 10 to 15 N·m or less.
- Do not move or swing the product holding the adjustment knob on the regulator.
- Do not apply pressure exceeding the pressure gauge's full scale. This will cause the pressure gauge to break. (Pay extra caution when using 0.2 and 0.4 MPa pressure gauges)

3. Lubricator

⚠ CAUTION

■ Adjustment of lubricator drop down

- Adjust the oil rate by turning the adjusting dome with bare hands. When closing the dome, tighten with a torque of 0.5 N·m or less. The numbers (scale) on the dial are a guide used after adjustment, and do not indicate the oil drip.

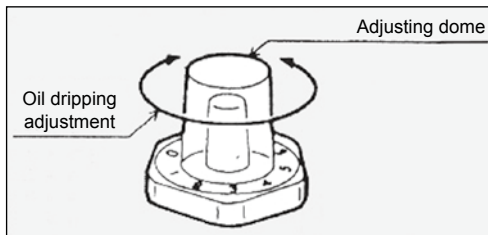

4. Pressure switch

⚠ CAUTION

■ How to mount pressure switch (PPD)

- Separate the body from the base.
- Attach an O ring.
 - * Refer to the outline drawings for the direct installation type (PPD-****-1F-1) (PPD-****-1F-2) on the left, and attach the O ring to the O ring groove with a clean finger.
- Install the base
 - Install the base with the two enclosed screws (M3).
 - * Carefully install at the designated position in the designated direction while taking care not to dislocate the O ring.
 - * Do not tighten one screw completely at once, and instead tighten the two screws so that they are balanced. (Tightening torque 0.5±0.1 N·m)

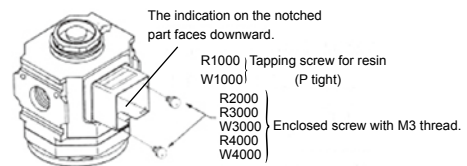

- Install and fix the body.
 - Make sure no dirt or foreign matter is on the base, and then insert the body. Make sure that the body does not catch on the base. Then, insert the two keys. While pressing the body exterior against the base, set the heads of the keys so that they face each other, then insert them so that they are completely stored in the recesses on the base.

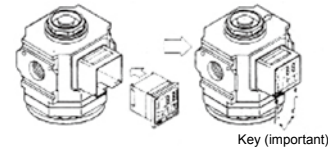

Note: Install both keys. Check that both keys are installed before pressurizing.

Note: When changing the position or orientation of the PPD which has been installed once, install using the new keys, O rings and installing screws enclosed with the option kit.

5. Pressure gauge

⚠ CAUTION

■ Pressure gauge

Repeated and sudden increases and decreases in pressure and pressure pulsation must be avoided because it could adversely shorten pressure gauge life. Either ease pressure fluctuation in the circuit or consult with CKD so that a pressure gauge with a cushioning screw can be prepared. Applying pressure exceeding the pressure range could damage the pressure gauge.

During Use & Maintenance

1. Common

⚠ WARNING

■ Regularly, once or more in six months, check the air filter and lubricator's plastic bowl for cracks, damage, and other deterioration. Cracks, damage or other deterioration could result in breakage, so if found, replace with a new bowl or with a metal bowl.

■ Check the air filter, lubricator plastic bowl, and lubricator drip window periodically for contamination.

- If parts are heavily contaminated or if transparency has dropped, replace with a new bowl or drip window.
- Use a diluted neutral household detergent to wash parts, and then rinse well with clean water. Use of other agents could result in breakage.

■ Removing filter, lubricator bowl

Before removing the bowl, the compressed air, discharge pressure in the bowl completely, and confirm that no residual pressure remains.

⚠ CAUTION

- Check the oil drip rate once a day. If the oil drip is faulty, problems could occur in the unit being lubricated.
- Do not branch the air into lubricating air and oilless air with a distributor. The lubricator oil could reverse flow.
- Filter element clogging will decrease vacuum source conductance. Regularly inspect, clean, and replace the element.
- Do not disassemble or modify the product.
- Read instructions and precautions enclosed with the product before starting use or maintenance.

How to discharge drain

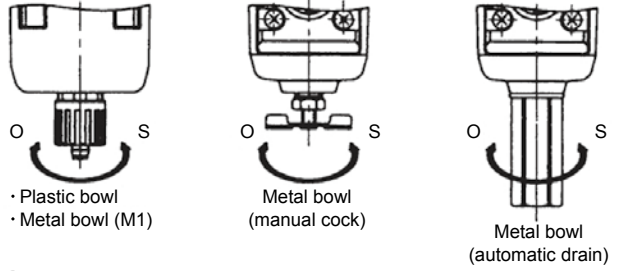

- Drainage is started when the cock is turned to the O side, and the discharge is stopped when the cock is turned in the S direction. Tighten in the S direction with your hands.
- When the automatic drain is provided, drainage is discharged automatically when it accumulates. Drainage is also discharged manually.

Removing resin bowl

2000, 3000, 4000 Series

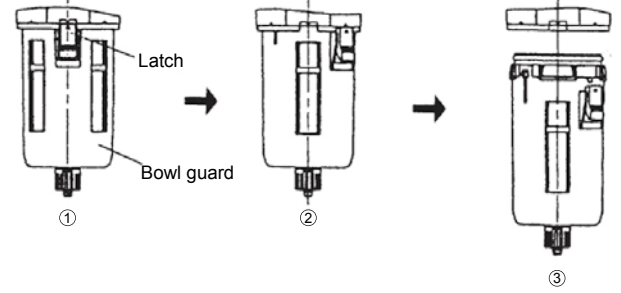

1000 Series

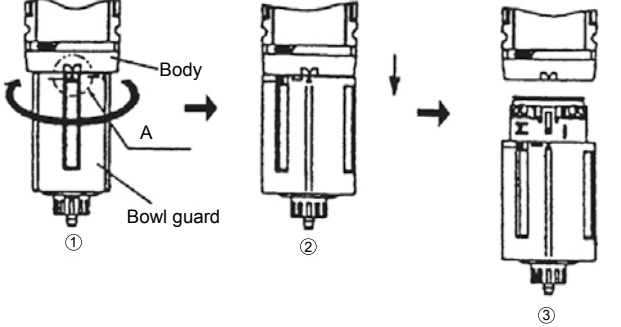

Removing metal bowl

2000, 3000, 4000 Series

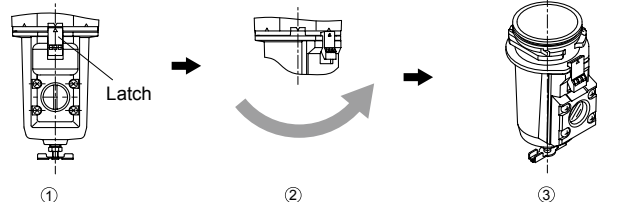

2. Filter-regulator

⚠ CAUTION

- Element of the W1000 to W4000 Series
Inspect the valve assembly when it is removed during maintenance.
Do not lose internal parts when removing the coil.

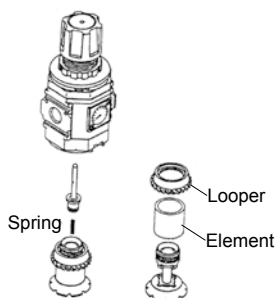

3. Filter

⚠ WARNING

- Drain so that air filter drainage does not accumulate beyond the maximum.
Components could malfunction if drainage flows into the secondary side.

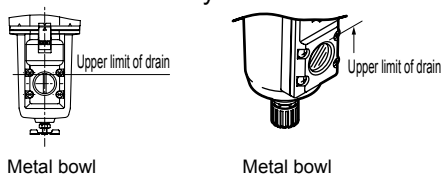

- The resin bowl must not be filled beyond the "MAX LEVEL" stamped on the bowl guard.

⚠ CAUTION

- Submicron 0.3 μ m element
Washing cannot restore functions. When the pressure drops to 0.07 MPa, replace the filter with a new one. (Excluding 1000 Series)
- Oil mist filter
The mantle (element) life ends after one year (6000 hours) or when pressure drops to 0.1 MPa (Except for the X type,) Replace the mantle when life is reached. (Do not touch the urethane foam layer during replacement.)

4. Regulator, filter with regulator

⚠ CAUTION

- Pull the pressure adjustment knob and release the lock before setting the regulator pressure. The regulator could be damaged if the pressure is set without unlock.

5. Lubricator

⚠ WARNING

- Use Class 1 turbine oil (nonadditive) ISO VG32 for the lubricator.
Use of other oil will result in damage or malfunction.
- Removing the lubricator's filling plug
To prevent the filling plug from popping out, loosen the filling plug by one turn, and then completely depressurize the bowl before removing the filling plug.
Wipe away any dirt around the fill plug that could scatter.

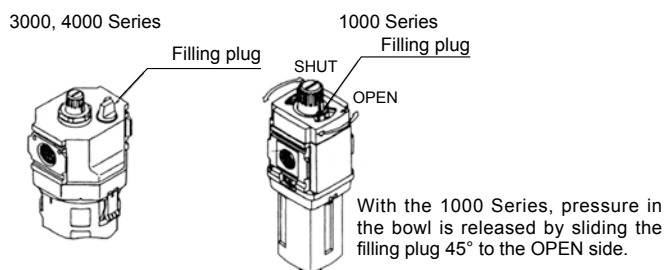

- Close the fill plug after lubricating.
- Do not remove the bowl without removing the filling plug while the bowl is pressurized. (L3000 to L4000)
- With the 1000 Series, never remove the bowl with the filling plug set to the SHUT side (while the bowl is pressurized). (L1000)

⚠ CAUTION

- Periodically replenish oil in the lubricator bowl so that it does not drop below the lower limit.
- When lubricating the L1000-W, pressure in the bowl is released by turning the fill plug. Refer to the above for the operation of the filling plug. (Lubrication can be carried out while the pipes are pressurized.)
Check that there is no pressure in the bowl, remove the bowl and bowl guard, and then directly lubricate to the bowl.
Refer to the previous page for details on removing the bowl.
- When lubricating L3000 to L4000, loosen the filling plug slightly to release the pressure in the bowl, and then remove the filling plug. Refer to the above for the operation of the filling plug.
(By removing the filling plug, lubrication can be carried out while the pipes are pressurized.)
Oil can also be supplied from the filling plug hole, and the bowl can be directly lubricated by removing the bowl and bowl guard.
Refer to the previous page for details on removing the bowl.

Specific precautions: F.R.L. components

Chemical resistance of plastic parts

⚠ WARNING

- The chemical resistance of plastic parts is shown below.
- Avoid using products in an atmosphere where chemicals are contained in compressed air, the atmosphere, or where they could adhere to parts.
- Use in this state could lead to bowl damage and accidents.
- Avoid using these types of chemicals or in an atmosphere containing these chemicals.
- A metal bowl is available if these chemicals must be used.

Chemical resistance of plastic bowl and body Use a metal bowl in an atmosphere containing the following chemicals.
Check whether the testing solutions, sealing agents and adhesives contain the following chemicals.

Types of chemicals	Categories of chemicals	Main products containing the chemical	Example of general usage	Polycarbonate bowl	Nylon Bowl	Nylon Body
Inorganic chemicals	Acid	Hydrochloride, sulfuric acid, fluorine, phosphoric acid, chromic acid, etc.	Acid washing of metals, acidic degreasing solution, coating fluid, etc.	×	×	×
	Alkaline	Alkalies such as caustic soda, caustic potash, calcium hydroxide, ammonium water, or sodium carbonate	Alkaline degreasing of metals Water-based coolant, leakage detection agent	×	○	○
	Inorganic salts	Alkalies such as caustic soda, caustic potash, calcium hydroxide, ammonium water, or sodium carbonate		×	○	○
Organic chemicals	Aromatic Hydrocarbon	Benzene, toluene, xylene, ethyl benzene, styrene, etc.	Contained in paint thinner (benzene, toluene, xylene)	×	×	×
	Chlorinated aliphatic hydrocarbon Hydrocarbon	Methyl chloride, ethylene chloride, methylene chloride, acetylene chloride, chloroform, trichylene, perchloro ethylene, carbon tetrachloride	Organic solvent based washing solution for metals (Trichylene, perchloro ethylene, carbon tetrachloride)	×	○	○
	Chlorinated aromatic Hydrocarbon	Chlorobenzene, dichlorobenzene, benzene hexachloride (B, H, C), etc.	Agricultural chemicals	×	○	○
	Petroleum components	Solvent naphtha, gasoline, kerosene		×	○	○
	Alcohol	Methanol, ethanol, cyclohexanol, benzyl alcohol	Anti-freeze Leakage detection agent	×	×	×
	Phenol	Carbolic acid, cresold, naphthol, etc.	Antiseptic solution.	×	×	×
	Ether	Methyl ether, methyl ethyl ether, ethyl ether	Brake oil additive	×	○	○
	Ketone	Acetone, methyl ethyl ketone, cyclohexanone, acetophenone, etc.		×	×	×
	Carboxylic acid	Formic acid, acetic acid, butyl acid, acrylic acid, oxalic acid, phthalic acid, etc.	Dust/jet-proof Dyes; oxalic acid for aluminum processing, Phthalic acid is used for paint base. Used as leakage detection agent	×	×	×
	Ester	Dimethyl phthalate (DMP), diethyl phthalate (DEP), dibutyl phthalate (DBP), dioctyl phthalate (DOP)	Lubricant, synthetic oil, additive for rust preventing agent Used as plasticizer for synthetic resin.	×	○	○
	Oxo acid	Glycocholic acid, lactic acid, malic acid, citric acid, tartarate		×	×	×
	Nitro compounds compounds	Nitromethane, nitroethane, nitroethylene, nitrobenzene, etc.		×	○	○
	Amine	Methylamine, diethylamine, ethylamine, aniline, acetoacetanilide, etc.	Brake oil additive	×	×	×
Nitrile	Acetonitrile, acrylonitrile, benznitrile, acetylidyne nitrile, etc.	Raw material for nitril rubber	×	○	○	

○: Permissible ×: Not permissible (plastic will be damaged)



Pneumatic component (Air unit (CXU Series))

Safety precautions

Always read this section before starting use.

Refer to the "Pneumatic, Vacuum and Auxiliary Components (No. CB-024SA)" for precautions for general purpose pneumatic pressure components.

Specific precautions: Air unit CXU Series

Design & Selection

- Use the T-type bracket in regular intervals.
Single support joiners can be used for three or fewer stations.

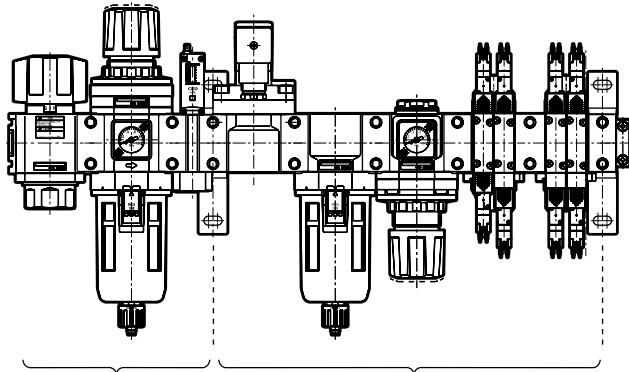

Use 3 stations or less
for single support.

Use 5 stations or less
for double support.

- When using 5 port pilot operated valve (CXU30-4G2) at maximum flow rate, use with 3 or less stations.

One station consists of two solenoid valves. Up to six solenoid valves can be used.

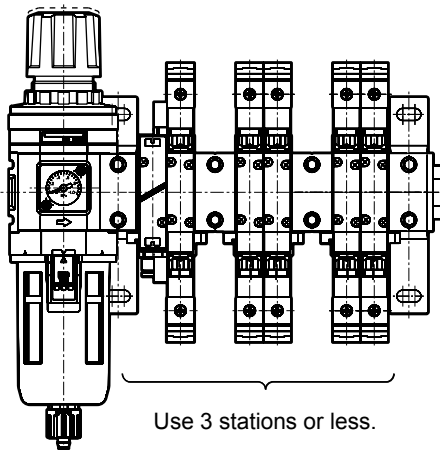

Use 3 stations or less.

- When using 2 port pilot operated solenoid valve (CXU10-EXA) at maximum flow rate
As a reference, use only 1 station when 1000 Series regulator is connected,
and use upto 4 stations when 3000 Series regulator is connected.

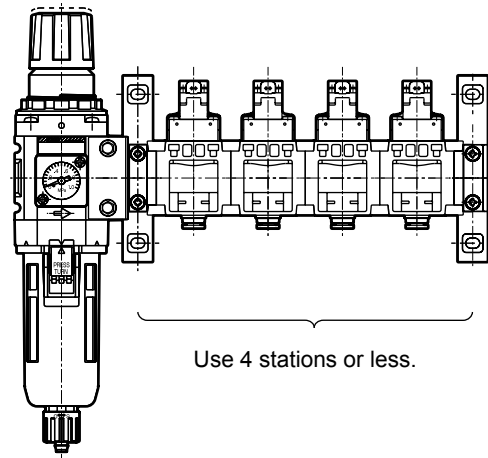

Use 4 stations or less.

Installation & Adjustment

- With the 1000 Series unit, the bracket may twist and rise on one side. Tighten and fix the bracket in this case. The bracket can be mounted stably and poses no problem for use.

- Precautions when selecting CXU-13-UN
If 1000 Series and 3000 Series are combined together with single support, its load may destroy the joiner.
Use double support.

- Tighten the fixing screw for the 1000 Series joiner with a torque of 1 to 1.2 N·m, tighten the fixing screw for the 3000 Series with a torque of 3 to 4 N·m.

Valve air unit

Manifold model no.

General Description

The valve air unit is a unit component that lets the solenoid valve be connected to components such as regulators. it can be used immediately without piping.

Features

- ① Simplified order form
The CXU can be ordered with only 1 form, making purchasing and delivery management easy.
- ② Reduce man-hours
The FR component and solenoid valve are connected as modules, eliminating work such as piping.
- ③ Low profile
Piping free, fitting free sleek design. Ideal for use in limited space.

Description of icons



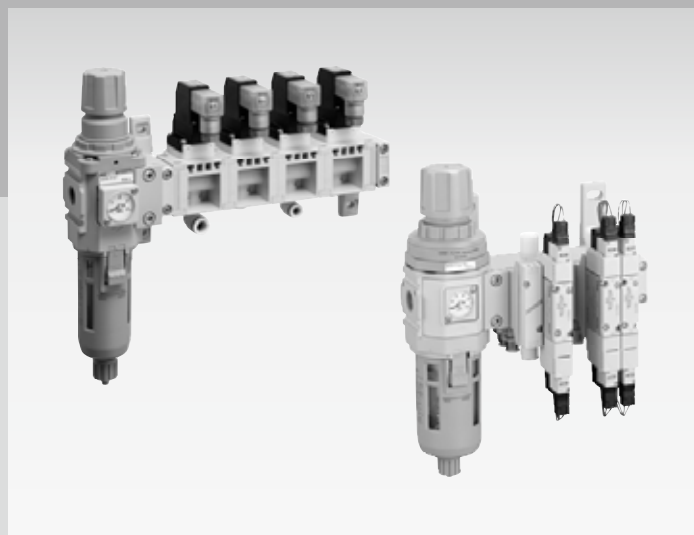

- ① Easy to select models
Eliminated complex options to allow easier selection.



CONTENTS

- 2 port pilot operated solenoid valve CXU10-GEXA Series 2
- 5 port pilot operated valve CXU30-M4G2 Series 6

Series Variation

Series Model no.	Voltage		Port					F.R. component			Electric connection		
	DC 24 V	AC 100 V	Connection Port size (IN)	Port size (OUT)				Regulator	Filter Regulator		Grommet lead	E-connector	DIN terminal box
				3/8	ø4	ø6	ø8		1/4	R2000			
<ul style="list-style-type: none"> ● 2 port pilot operated solenoid valve CXU10-GEXA   NEW	●	●	●	●	●			●	●			●	
<ul style="list-style-type: none"> ● 5 port pilot operated valve CXU30-M4G2  	●	●	●	●	●			●		●		●	

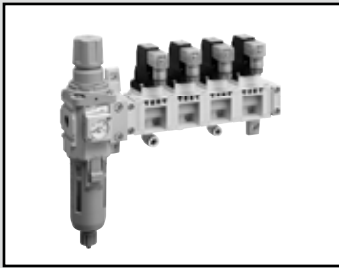

2 port pilot operated solenoid valve for compressed air
Manifold model no.

CXU10-GEXA Series

NC (normally closed)

Order as a manifold with a regulator connected



JIS symbol

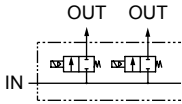

(e.g.) CXU10-GEXA-C6-R-3-2C-3

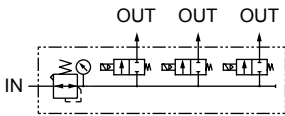

Specifications

Descriptions		CXU10-GEXA			
Working fluid	Compressed air				
Working pressure differential range MPa	0.01 to 0.7				
Max. working pressure MPa	0.7				
Withstanding pressure MPa	1.05				
Fluid temperature °C	0 to 55				
Ambient temperature °C	-5 to 55				
Atmosphere	Does not contact water, corrosive or flammable gas.				
Valve structure	Pilot operated diaphragm structure				
Valve leakage cm ³ /min (ANR)	10 or less				
Mounting	Flexible				
Port size (IN)	IN: Rc3/8				
Port size (OUT)	ø6 push-in fitting	ø6 push-in fitting L type	ø8 push-in fitting	ø8 push-in fitting L type	
C [dm ³ / (s·bar)] Note 2	1.6		3		
b	0.37		0.32		
Electrical specifications					
Rated voltage	100VAC, 24VDC				
Rated voltage VA	1.2				
Power consumption W DC	0.6				
Heat proof class	B				
Protective structure (IEC standards 529)	Lead wire type: IPX0, with DIN terminal box: IPX5				

Note 1: Voltage fluctuation range is ±10%

Note 2: Effective sectional area S and sonic conductance C are converted as $S \div 5.0 \times C$.

Regulator specifications

Set pressure range MPa	0.05 to 0.7	Note 3
Relief	With relief mechanism	
Port size	Rc3/8	

Filter specifications

Filtration rating μm	5	
Drain capacity cm ³	12	
Port size	Rc3/8	

Note 3: Set pressure range will be limited by the working pressure of CXU10-EXA.

Weight

(unit: kg)

Descriptions	Descriptions
F.R. components (includes T type brackets and joiners)	
A: Piping adaptor	0.21
R: Regulator	0.58
RT8: Regulator (without pressure gauge)	0.57
W: Filter·regulator	0.7
WT8: Filter·regulator (without pressure gauge)	0.69
2 port solenoid valve	
CXU10-EXA (discrete valve and joiner) Note 4	0.11

Note 4: Models with DIN terminal box weighs 20g more.

Weight: FR device used + 2 port solenoid valves X number of stations.

How to order

CXU10-GEXA-C6-R-3-2C-3

A Port size (OUT)

B FR component options

C Solenoid valve station no.

D Coil option

E Rated voltage

Symbol	Descriptions	
A Port size (OUT)		
C6	ø6 push-in fitting	
CL6	ø6 push-in fitting L type	
C8	ø8 push-in fitting	
CL8	ø8 push-in fitting L type	
B FR component options		
Component options	A	Pipe adaptor (Rc3/8)
	R	Regulator (R2000-10-W-X2 Note 2)
	RT8	Regulator (R2000-10-W-T8X2 Note 2) Without pressure gauge (port Rc1/4 open)
	W	Filter·Regulator (W2000-10-W-F1 Note 2)
Note 1	WT8	Filter·Regulator (W2000-10-W-F1 T8 Note 2) Without pressure gauge (port Rc1/4 open)
	Direction	
	Blank	IN side Left
	X	IN side Right
C Solenoid valve station no.		
1	1 station	
to	to	
4	4 stations	
D Coil option Note 3, 4		
2C	Standard	Lead wire (without indicator light and surge suppressor)
2H	Option	DIN terminal box (Pg7). with indicator light inside terminal box
2HS		DIN terminal box (Pg7). with indicator light and surge suppressor inside terminal box
E Rated voltage		
1	100 VAC	
3	24 VDC	

⚠ Cautions for model No. selection

Note 1: Standard filter-regulator is NC automatic drain type.

Select "A" unless component option R, RT, W, WT8 is selected.

Multiple FR device options cannot be selected.

Note 2: Model no. for IN side Left (FR device direction option "Blank").

Note 3: Refer to the table on the right for available combinations of coil options and voltage.

Note 4: Contact CKD for models with M12 connector cable.

Coil Option	Voltage	
	1	3
2C	●	●
2H	●	
2HS		●

Select a combination with a circle mark.

Internal structure drawing

Models	Listed catalog and page no.
CXU10-EXA	Page 15
CXU10-TA	Catalog No.CC-901A
CXU10-MA	Catalog No.CC-901A
R2000	Catalog No.CB-024A
W2000	Catalog No.CB-024A

Valve air unit

Air unit component

Custom air unit

Handled as a custom order

CXU10-GEXA Series

Dimensions

- Grommet lead wire type
CXU10-GEXA-*A*⁻2C-*
Cartridge fitting: Straight

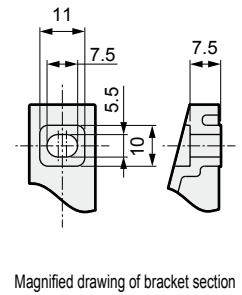
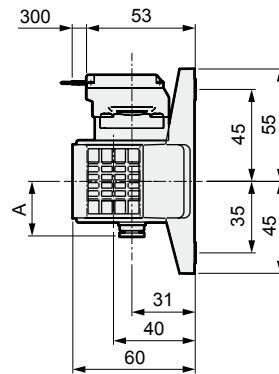
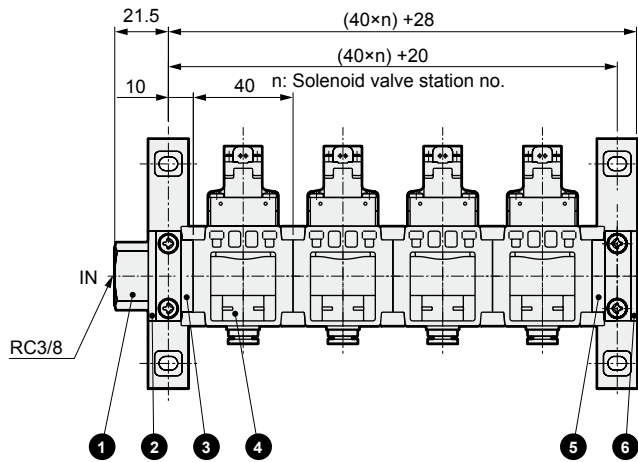

Configuration table

No.	Product name	Model no.
1	Piping adaptor Note 1	(FR component options -A)
2	T type bracket	B110-W
3	Turn adapter	CXU10-TA-00
4	2 port pilot operated solenoid valve	CXU10-EXA-□
5	Turn adapter	CXU10-TA-00
6	Masking adaptor	CXU10-MA-00-B

Note 1: The final product may differ depending on FR component options.

Option dimensions

Option	A	B	C	D	E
C6	27	ø6 push-in fitting	-	-	-
CL6	-	ø6 push-in fitting	31	37	18.5
C8	27	ø8 push-in fitting	-	-	-
CL8	-	ø8 push-in fitting	32	39	21

Elbow type fitting

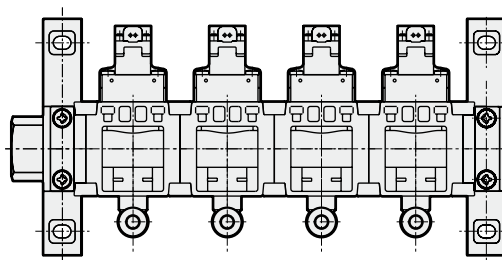

n: Solenoid valve station no.

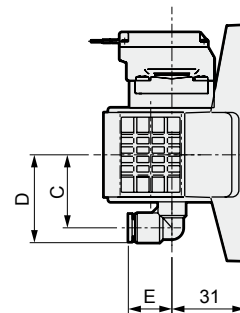

- With DIN terminal box (Pg7) CXU10-GEXA-*A*⁻2HS-*

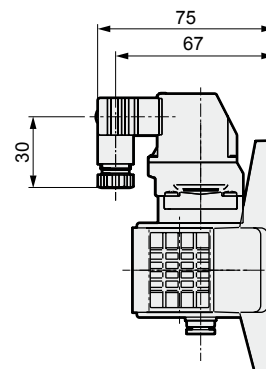
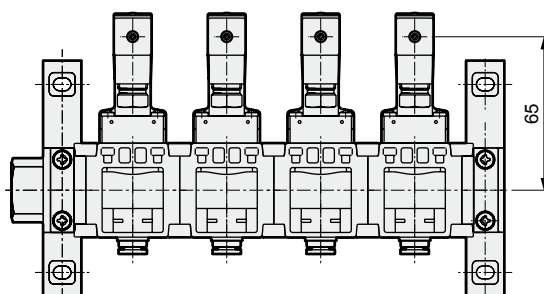

Dimensions

- F.R. component option: regulator type
CXU10-GEXA-*^R_{RT8}-*-*

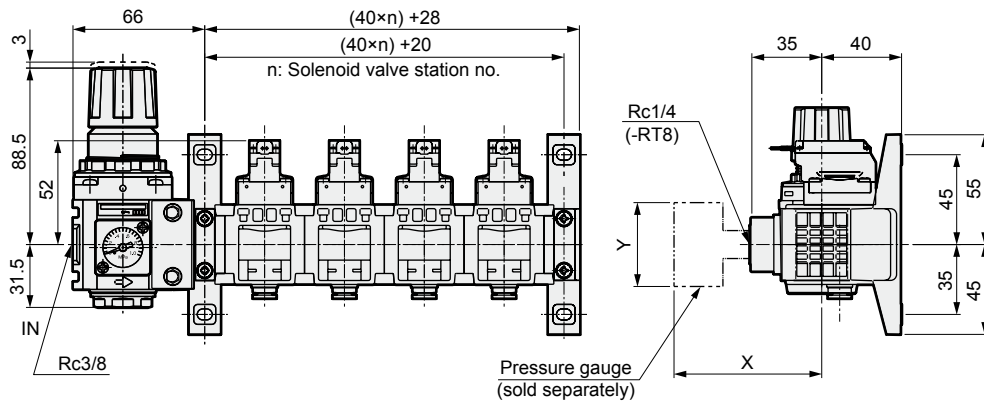

Pressure gauge dimensions

Pressure gauge (sold separately)	X	Y
G49D	(73.5)	ø43.5
G59D	(76)	ø52
G40D	(75.5)	ø42.5
G50D	(75.5)	ø52.5
G41D	(74)	ø42
G52D	(79)	ø52.5

- F.R. component option: filter regulator type
CXU10-GEXA-*^W_{WT8}-*-*

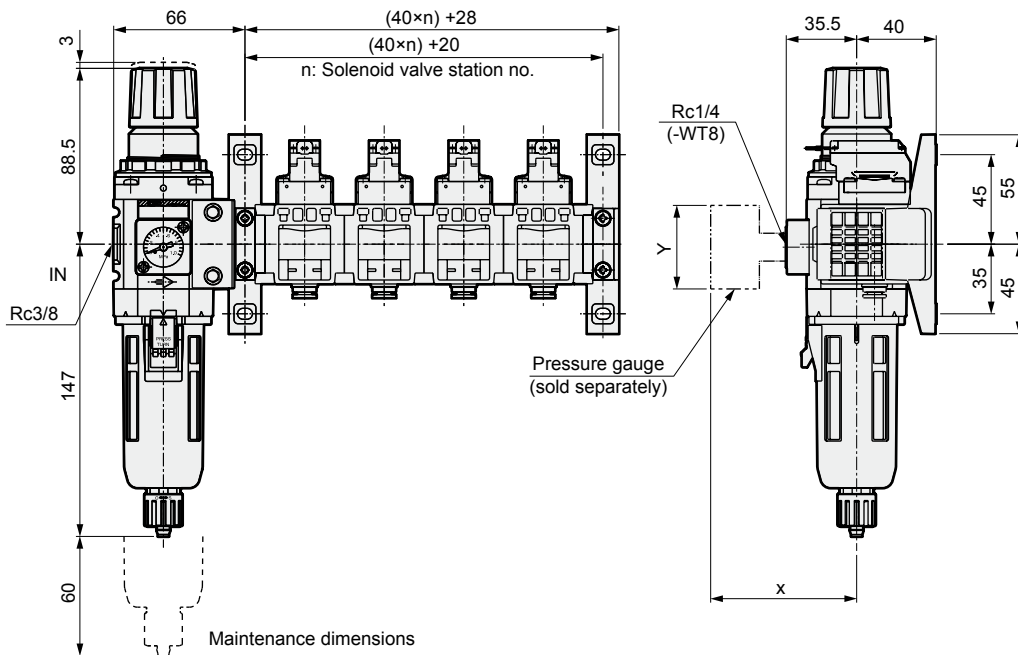

Pressure gauge dimensions

Pressure gauge (sold separately)	X	Y
G49D	(73.5)	ø43.5
G59D	(76)	ø52
G40D	(75.5)	ø42.5
G50D	(75.5)	ø52.5
G41D	(74)	ø42
G52D	(79)	ø52.5

- F.R. components option: reverse flow
CXU10-GEXA-*^R_{RT8}X-*-*

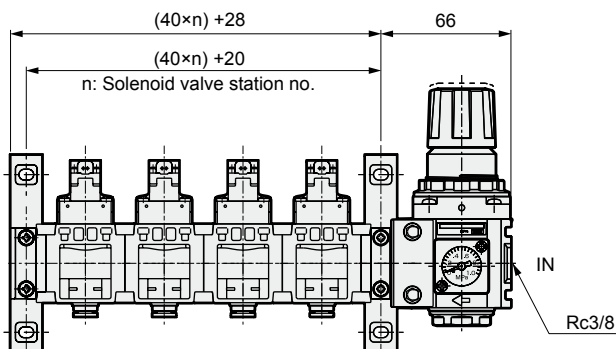

Note: When reverse flow option X is selected, the IN side and FR device are on the right.
The drawing at left is for the regulator.

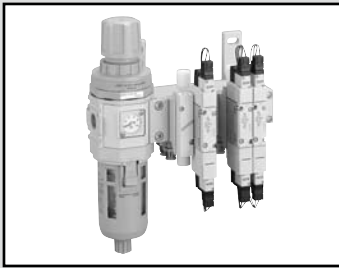

5 port pilot operated valve

CXU30-M4G2 Series

Order in manifolds with a regulator connected



Common specifications

Descriptions	Descriptions
Type of valve/operation method	Pilot operated soft spool valve
Working fluid	Compressed air
Max. working pressure MPa	0.7
Min. working pressure MPa	0.2(2 position, 3 position)
Withstanding pressure MPa	1.05
Fluid temperature °C	5 to 55
Ambient temperature °C	-5 to 55 (to be unfrozen)
Working environment	Area without corrosive or explosive gases and away from water.
Port size	A/B port Push-in fitting ø4, ø6, ø8
	R1, R2 port Rc1/4
Manual override	Locking/non-locking common type
Pilot exhaust method	Main valve, pilot valve common exhaust type
Lubrication Note 1	Not required
Protective structure Note 2	Dust proof
Vibration/impact m/s ²	50 or less / 300 or less

Note 1: Use the turbine oil Class 1 ISO VG32 if lubricated.

Excessive or intermittent lubrication results in unstable operation.

Note 2: Check that water drops or oil, etc., do not come into contact.

IP65 (jet-proof type) is used for DIN terminal box specifications.

Note that the box must be fixed using the specified adaptive cord outer diameter and tightening torque.

JIS symbol

2-position single solenoid

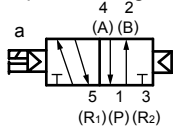

2-position double solenoid

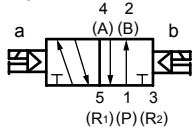

3-position all ports closed

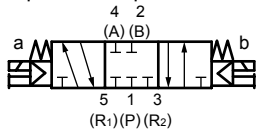

3 position ARB connection

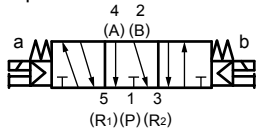

3-position PAB connection

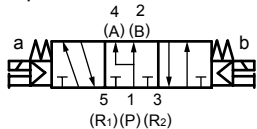

(e.g.) CXU30-M4G2-1130-C6-R-B-3

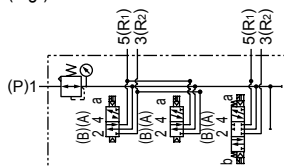

Weight

(unit: kg)

Descriptions		Descriptions	
F.R. components (includes T type brackets and joiners)			
A: Piping adaptor		0.54	
R: Regulator		0.8	
RT8: Regulator (without pressure gauge)		0.79	
W: Filter-regulator		1.06	
WT8: Filter-regulator (without pressure gauge)		1.05	
5 port valve: solenoid position		Discrete valve	
Without solenoid valve: masking plate		Valve sub-base	
2-position	Single	E-connector	0.32
		DIN terminal	
	Double	E-connector	
		DIN terminal	
3-position	All ports closed	E-connector	
		DIN terminal	

Weight: FR device used + solenoid valve ① to ④ + valve sub-base.

Flow characteristics

Solenoid position	P→A/B		A/B→R1/R2	
	C [dm ³ / (s·bar)]	b	C [dm ³ / (s·bar)]	b
2-position	2.3	0.29	1.8	0.24
3-position	All ports closed	2.1	2.3	0.27
	A/B/R connection	2.1	1.7	0.2
	P/A/B connection	2.2	2.4	0.29

Note 1: Effective sectional area S and sonic conductance C are converted as $S \approx 5.0 \times C$.

Note 2: The value for 2 position and ABR connection is the value when a check valve is integrated.

Regulator specifications	
Set pressure range MPa	0.2 to 0.7 Note 3
Relief	With relief mechanism
Port size	Rc3/8
Filter specifications	
Filtration rating μm	5
Drain capacity cm ³	45
Port size	Rc3/8

Note 3: Set pressure range will be limited by the working pressure of CXU30-4G2.

How to order

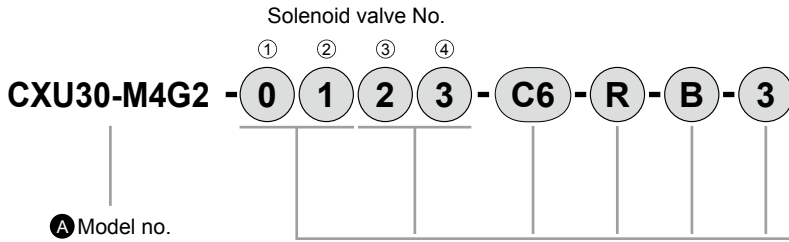

A Model no.

B Solenoid valve ①, solenoid position ② Note 7, 8

C Solenoid valve ③, solenoid position ④ Note 7, 8

D Port size (OUT)

E FR component options

F Electric connection

G Rated voltage

Symbol	Descriptions
B Solenoid valve ①, solenoid position ②	
0	Without solenoid valve: masking plate
1	2-position single solenoid
2	2-position double solenoid
3	3-position all ports closed
4	3-position ABR connection
5	3-position PAB connection

C Solenoid valve ③, solenoid position ④	
Blank	Without sub-base
0	Without solenoid valve: masking plate
1	2-position single solenoid
2	2-position double solenoid
3	3-position all ports closed
4	3-position ABR connection
5	3-position PAB connection

D Port size (OUT)	
C4	ø4 push-in fitting
C6	ø6 push-in fitting
CL6	ø6 push-in fitting L (rear)
C8	ø8 push-in fitting

E FR component options		
Component options	A	Pipe adaptor (Rc3/8)
	R	Regulator (R2000-10-W-X2 Note 5)
	RT8	Regulator (R2000-10-W-T8X2 Note 5) Without pressure gauge (port Rc1/4 open)
	W	Filter·Regulator (W3000-10-W-F Note 5)
	WT8	Filter·Regulator (W3000-10-W-FT8 Note 5) Without pressure gauge (port Rc1/4 open)
Direction	Blank	IN side Left
	X	IN side Right

F Electric connection		
B	DIN terminal box (Pg7)	With surge suppressor and light
E20	E-connector Lead wire (500mm) with surge suppressor and light	

G Rated voltage	
1	100VAC (rectified bridge integrated)
3	24VDC

⚠ Cautions for model No. selection

Note 1: The GWS*-8-S fitting can be mounted on the R1 port.

Note 2: Check valve is provided as standard.

The 3 position all ports closed and P/A/B connection cannot be used with the check valve.

Note 3: If port size, wire connection or voltage is different for each solenoid valve, the product will be processed as a customized order.

Note 4: Standard filter·regulator is N.O. automatic drain type. Multiple FR device options cannot be selected.

Note 5: Model no. for IN side Left (FR device direction option "No symbol").

Note 6: Two silencers (SLW-8S) are enclosed with one sub-base.

Note 7: Refer to dimensions drawings for positions of solenoid valves ① to ④.

Note 8: When masking plates are used for all solenoid valves, wire connection and rated voltage options must be left blank.

Internal structure drawing

Models	Listed catalog and page no.
CXU30-4G2	Page 26
CXU10-MA	Page 39
CXU13-CA	Page 40
R2000	Catalog No.CB-024A
W3000	Catalog No.CB-024A

CXU30-M4G2 Series

Dimensions

CXU30-M4G2 -A

- E connector type (E)
- Cartridge fitting: Straight

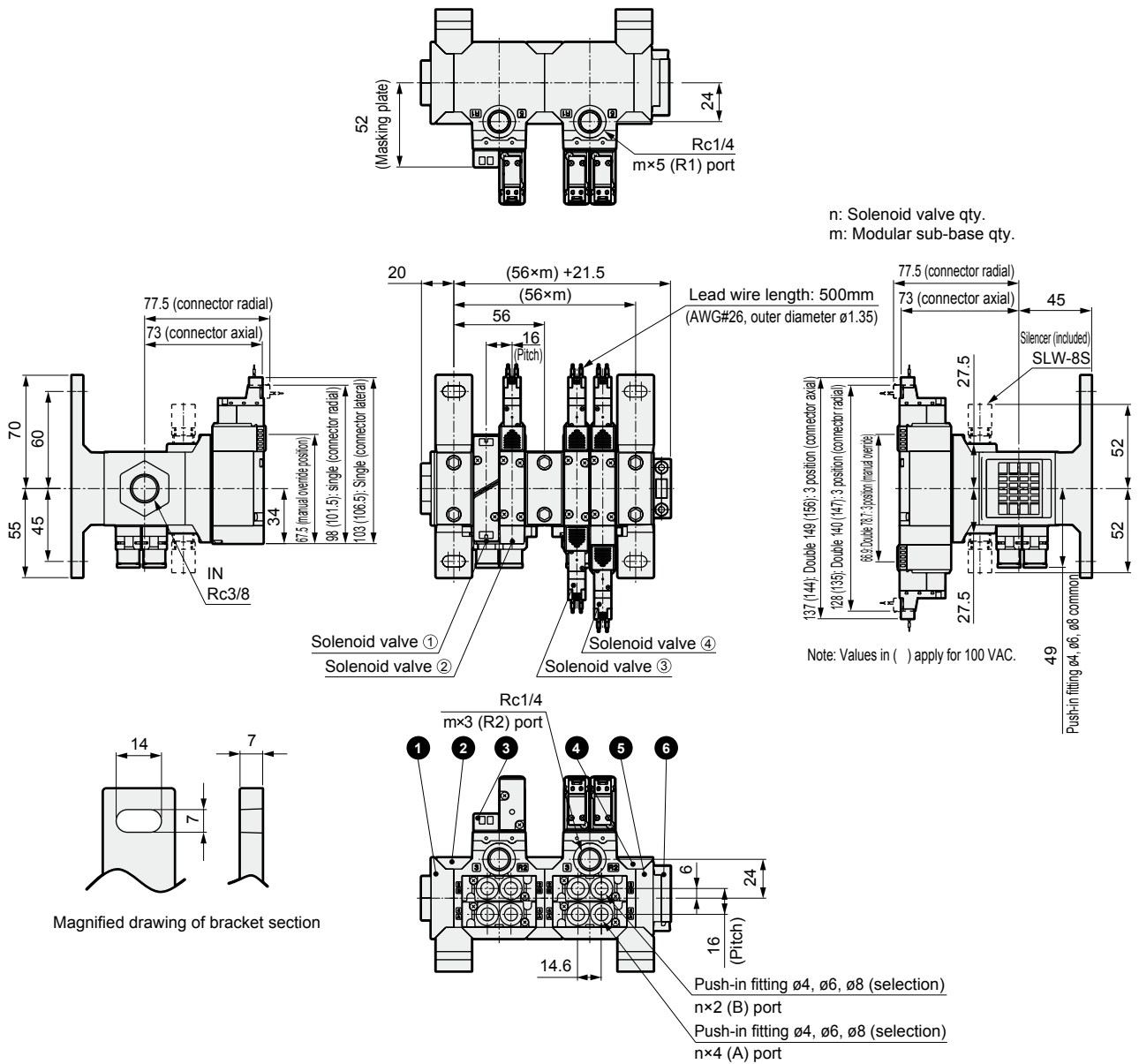

Configuration table

No.	Product name	Model no.
1	Piping adaptor Note 1	(FR component options -A)
2	T type bracket	B310-W
3	5 port pilot operated valve	CXU30-4G2-*
4	T type bracket	B310-W
5	Module transform adaptor	CXU13-CA-00
6	Masking adapter	CXU10-MA-00

Note 1: The final product may differ depending on FR component options.

Solenoid valve and modular sub-base quantity

Model no.	Solenoid valve qty.	Modular sub-base qty.
CXU30-M4G2-①②	2	1
CXU30-M4G2-①②③④	4	2

Note: Masking plate count as a solenoid valve quantity.
There will be 2 solenoid valves for each modular sub base.

Dimensions

- DIN terminal box type B
Cartridge fitting: Straight
2-position single solenoid

Double, 3 position

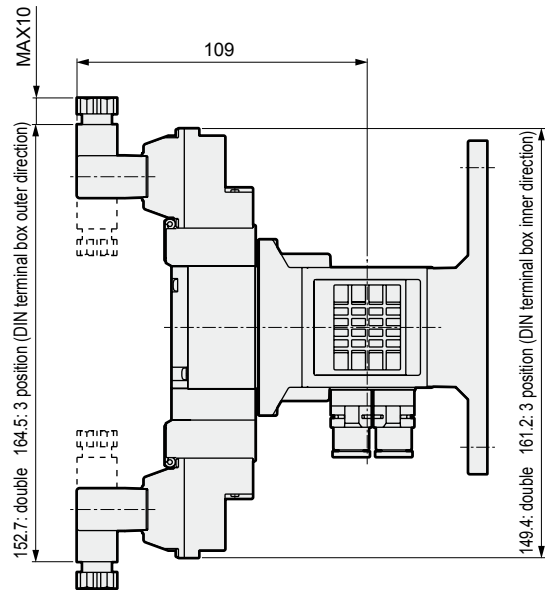
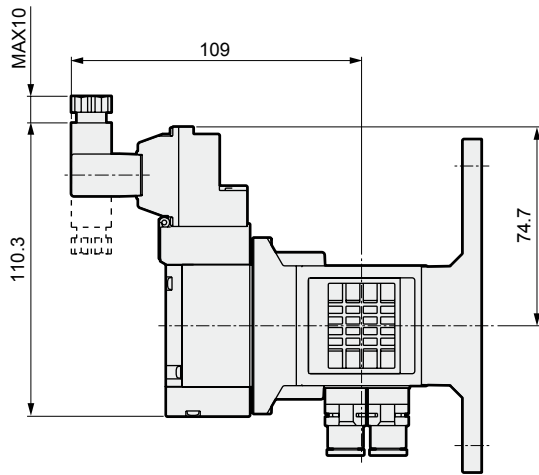

Note: The DIN terminal box assembly is shipped facing inward.

- ø6 push-in fitting L (rear)

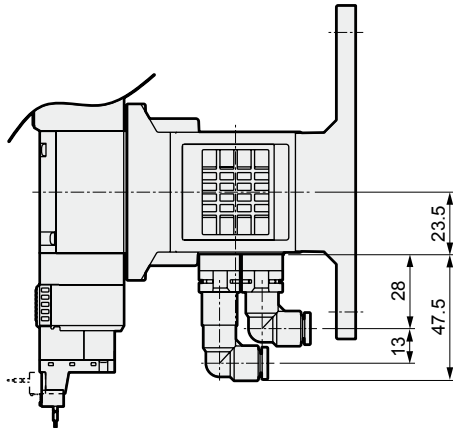

- F.R. component option: regulator type
CXU30-M4G2-**-**^R_{RT8}-**-**

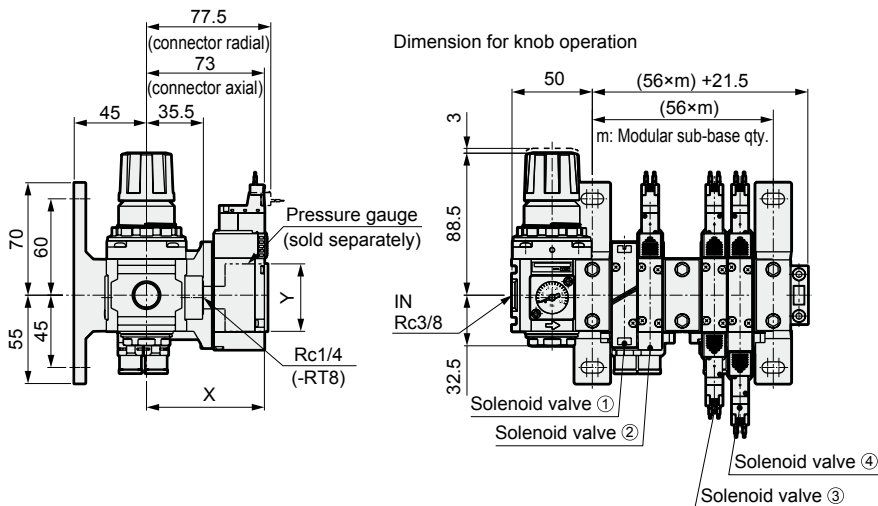

Pressure gauge dimensions

Pressure gauge (sold separately)	X	Y
G49D	(73)	ø43.5
G59D	(75.5)	ø52
G40D	(75)	ø42.5
G50D	(75)	ø52.5
G41D	(73.5)	ø42
G52D	(78.5)	ø52.5

Refer to catalog No. CB-024SA for the discrete model no. of the pressure gauge.

CXU30-M4G2 Series

Dimensions

- F.R. component option: filter regulator type
CXU30-M4G2-**-*-^W_{WT8}-**

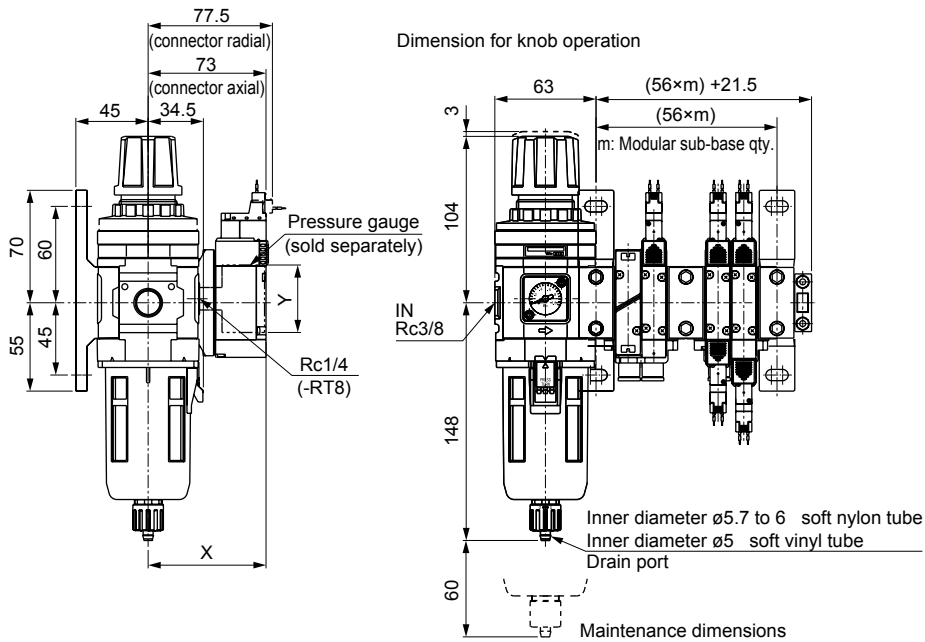

Pressure gauge dimensions

Pressure gauge (sold separately)	X	Y
G49D	(69.5)	ø43.5
G59D	(72)	ø52
G40D	(71.5)	ø42.5
G50D	(71.5)	ø52.5
G41D	(70)	ø42
G52D	(75)	ø52.5

- F.R. components option: reverse flow
CXU30-M4G2-**-*-^R_{RT8}-X-**-*

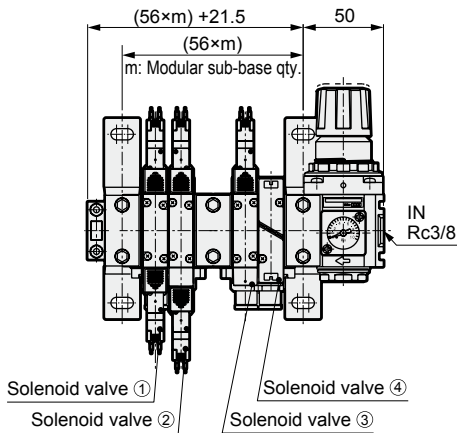

Note: When reverse flow option X is selected, the IN side and FR device are on the right.
The solenoid valve is arranged in order from the left.
The drawing at left is for the regulator.

Air unit component

Discrete model no.

Overview

Air unit components are easy to add on to existing units. It is also easily available for maintenance as well. General purpose components can be purchased together and assembled with air unit components.

Features

- ① Modular connection of solenoid valves.
Connect 2 port, 5 port valves to conventional F.R.L.s.
- ② Connect easily with a joiner
Conventional piping materials and tubes are not used, so there is no possibility of foreign materials entry or pressure loss.
- ③ Various modular components available
Modules can be split into four directions, twisted 90°, and resized.

Description of icons



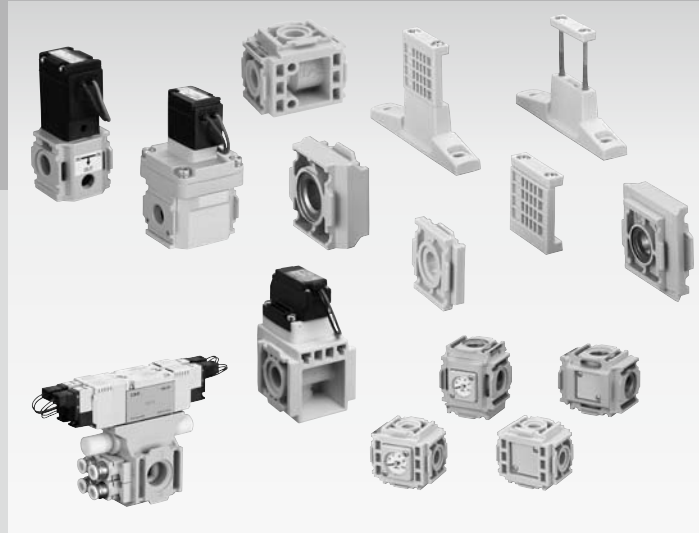







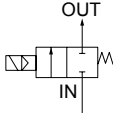

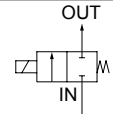
- ① **IN Gasket**
A gasket is required for connecting module inlets.
- ② **Thread free open type**
Since there is no connection screw is provided, a masking adapter or piping adapter is required for use at the terminal.
- ③ **Expandable**
IN structures are used on both sides of the module connection section, making it easy to expand stations.
- ④ **In line**
The component can be used as main inline. This structure is the opposite of the expandable type.

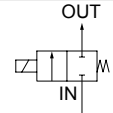

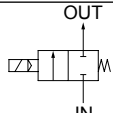

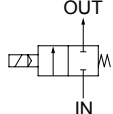

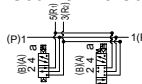

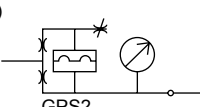



CONTENTS

● 2 port pilot operated solenoid valve CXU10-EXA Series	14
● 2 port direct acting solenoid valve CXU10-FAB3 Series	16
● 2 port direct acting solenoid valve CXU30-FAB4U Series	18
● 2 port pilot kick solenoid valve CXU30-ADK Series	20
● 2 port pilot operated solenoid valve CXU30-FAD Series	22
● 5 port pilot operated valve CXU30-4G2 Series	24
● Contact confirmation switch GPS2, MGPS2 Series	30
● Modular check valve CXU10-CHV Series	34
● 4 directional distributor CXU10-D4 Series CXU30-D4 Series	36
● Turn adapter CXU10-TA Series CXU30-TA Series	38
● Masking adapter CXU10-MA Series	39
● Module transform adaptor CXU13-CA Series	40
● Bracket, joiner, O-ring/gasket, pipe plug B-W J-W ORING GASKET CXU-PP	41

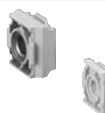
<Solenoid valve>

Series	Major applications	JIS symbol	Model no.
<ul style="list-style-type: none"> ● 2 port pilot operated solenoid valve IN Gasket Expandable Screw Free open type 	Air blow		CXU10-EXA
<ul style="list-style-type: none"> ● 2 port direct acting solenoid valve IN Gasket Expandable Screw Free open type 	Air blow		CXU10-FAB3
<ul style="list-style-type: none"> ● 2 port direct acting solenoid valve IN Gasket Expandable Screw Free open type 	Air blow		CXU30-FAB4U
<ul style="list-style-type: none"> ● 2 port pilot kick solenoid valve Screw Free open type In line 	ON/OFF of main		CXU30-ADK
<ul style="list-style-type: none"> ● 2 port pilot operated solenoid valve Screw Free open type In line 	ON/OFF of main		CXU30-FAD
<ul style="list-style-type: none"> ● 5 port pilot operated valve IN Gasket Expandable Screw Free open type 	Cylinder actuation	(e.g.) CXU30-4G2-13-C6-B-1 	CXU30-4G2
<ul style="list-style-type: none"> ● Contact confirmation switch 	Workpiece contact confirmation Clamp confirmation	(e.g.) 	GPS2 MGPS2

<Distributor, adaptor>

Series	Major applications	Applications	Model no.
<ul style="list-style-type: none"> ● Modular check valve IN Gasket Screw Free open type 	Reverse flow prevention		CXU10-CHV
<ul style="list-style-type: none"> ● 4 directional distributor IN Gasket Screw Free open type Note 2 	Branch to 4 directions		CXU10-D4 CXU30-D4
<ul style="list-style-type: none"> ● Turn adaptor IN Gasket Screw Free open type 	Convert module direction by 90°		CXU10-TA CXU30-TA
<ul style="list-style-type: none"> ● Masking adaptor 	Masking the module		CXU10-MA
<ul style="list-style-type: none"> ● Module transform adaptor IN Gasket Screw Free open type 	Connecting 1000 Series and 3000 Series		CXU13-CA

Note 1: Effective sectional area S and sonic conductance C are converted as $S \approx 5.0 \times C$.

	Module		Port size (OUT)						Flow characteristics C [dm ³ / (s·bar)] Note 1	Page	
	1000 Series	2000 3000 Series 4000	ø4	ø6	ø8	1/8	1/4	3/8			1/2
	●			●	●					1.4 to 3.2	14
	●			●	●					1.2	16
		●						●		2.1	18
		●								11	20
		●								18	22
		●	●	●	●					2.2 to 2.7	24
	●					●				-	30

Note 2: CXU has port size.

	Module		Port size	Page
	1000 Series	2000 3000 Series 4000	3/8	
	●			34
	●			36
		●	●	
	●			38
		●		39
	●			
	●			41

Valve air unit

Air unit component

Custom air unit

Handled as a custom order

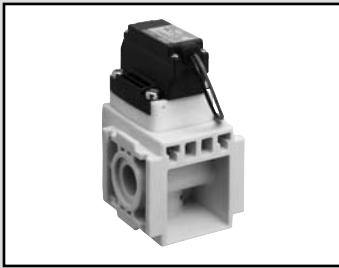

2 port pilot operated solenoid valve for compressed air

CXU10-EXA Series

N.C. (normally closed) type, diaphragm structure type
 Modular connection with 1000 Series
 Ideal for modular component blow valves

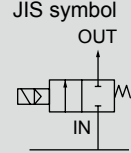

Screw free
open type

IN
Gasket

Expandable

Specifications

Descriptions	CXU10-EXA			
Working fluid	Compressed air			
Working pressure differential range MPa	0.01 to 0.7			
Max. working pressure MPa	0.7			
Withstanding pressure MPa	1.05			
Fluid temperature °C	0 to 55			
Ambient temperature °C	-5 to 55			
Atmosphere	Does not contact water, corrosive or flammable gas.			
Valve structure	Pilot operated diaphragm structure			
Valve leakage cm ³ /min	10 or less			
Mounting	Flexible			
Port size (IN)	None			
Port size (OUT)	ø6 push-in fitting	ø6 push-in fitting L type	ø8 push-in fitting	ø8 push-in fitting L type
C [dm ³ / (s·bar)] Note 2	1.6		3	
b	0.37		0.32	
Weight g Note 3	98	95	98	100
Electrical specifications				
Rated voltage	100VAC (50/60Hz), 24VDC Note 1			
Apparent power VA	1.2			
Power consumption W DC	0.6			
Heat proof class	B			
Protective structure (IEC standards 529)	Lead wire type: IPX0, with DIN terminal box: IPX5			

Note 1: Voltage fluctuation range is ±10%

Note 2: Effective sectional area S and sonic conductance C are converted as $S \approx 5.0 \times C$.

Note 3: Models with DIN terminal box weighs 20g more.

How to order

CXU10-EXA - C6 - 2C - 1

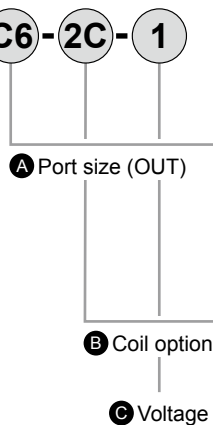

Symbol	Descriptions	
A Port size (OUT)		
C6	ø6 push-in fitting	
CL6	ø6 push-in fitting L type	
C8	ø8 push-in fitting	
CL8	ø8 push-in fitting L type	
B Coil option Note 1, 2		
2C	Standard	Lead wire (without indicator light and surge suppressor)
2H	Option	DIN terminal box (Pg7). with indicator light inside terminal box
2HS		DIN terminal box (Pg7). with indicator light and surge suppressor inside terminal box
C Voltage Note 1		
1	100VAC	
3	24VDC	

⚠ Cautions for model No. selection

Note: Joiner set and a gasket included

Coil Option	Voltage	
	1	3
2C	●	●
2H	●	
2HS		●

Select from the circle mark above.

Note 1: Refer to the table on the left for available combinations of coil options and voltage.

Note 2: Contact CKD for models with M12 connector cable.

Internal structure and parts list

● CXU10-EXA

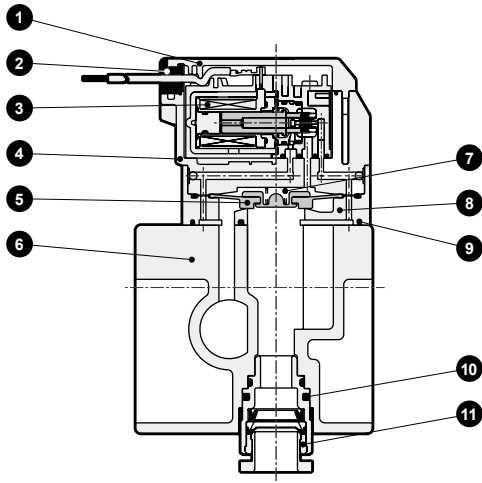

No.	Parts name	Material	
1	Cover (Note 1)	PBT	Polybutylene terephthalate
2	Bush	NBR	Nitrile rubber
3	Coil assembly	—	—
4	Stuffing	PPS	Polyphenylene sulfide
5	Diaphragm assembly	H-NBR/PPS	Hydrogenated nitrile rubber/polyphenylene sulfide
6	Body	PA66	Polyamide resin
7	Spring	SUS	Stainless steel
8	Valve body	PBT	Polybutylene terephthalate
9	Gasket	H-NBR	Hydrogenated nitrile rubber
10	Pin	SUS	Stainless steel
11	Fitting		

Note 1 PA66, polyamide will be used if DIN terminal box is included.

Dimensions

- Grommet lead wire type
CXU10-EXA-*-2C-*
Cartridge fitting: Straight

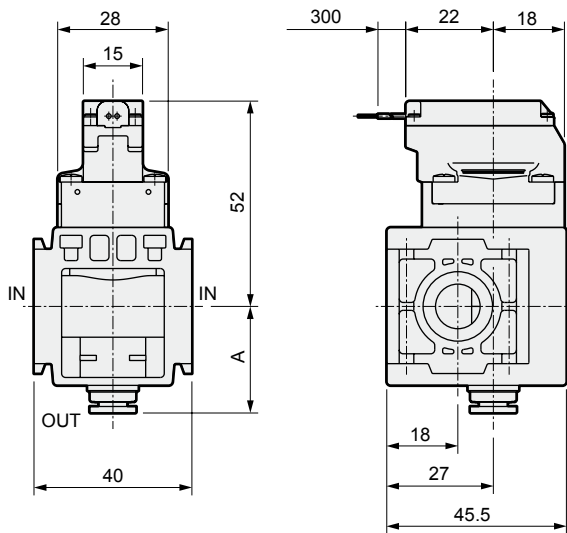

- With DIN terminal box type (Pg7) type
CXU10-EXA-*-2HS-*

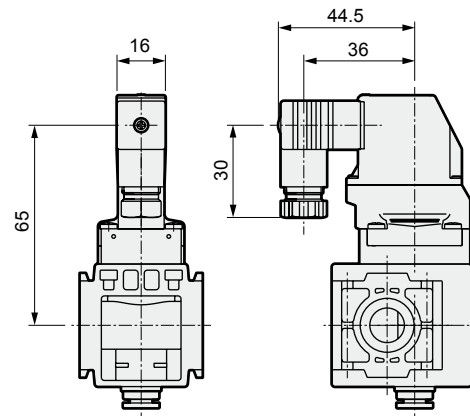

Elbow type fitting

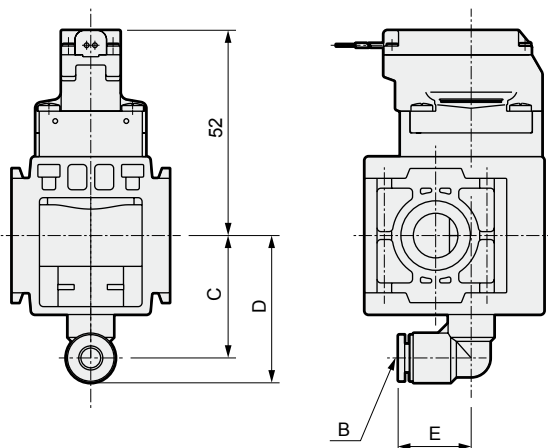

Option dimensions

Option	A	B	C	D	E
C6	27	ø6 push-in fitting	-	-	-
CL6	-	ø6 push-in fitting	31	37	18.5
C8	27	ø8 push-in fitting	-	-	-
CL8	-	ø8 push-in fitting	32	39	21

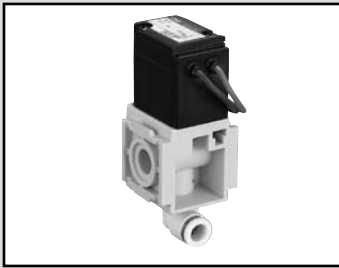

2 port direct acting solenoid valve

CXU10-FAB3 Series

NC (normally closed)
Modular connection with 1000 Series
Ideal for modular component blow valves

JIS symbol

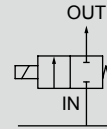

Screw free
open type

IN
Gasket

RoHS

Expandable

Specifications

Descriptions	CXU10-FAB3	
Working fluid	Compressed air	
Working pressure differential range MPa	AC: 0 to 1.0, DC: 0 to 0.6	
Max. working pressure MPa	1	
Withstanding pressure MPa	1.5	
Fluid temperature °C	AC: 5 to 60, DC: 5 to 40	
Ambient temperature °C	AC: 5 to 60, DC: 5 to 40	
Atmosphere	Does not contact water, corrosive or flammable gas.	
Valve structure	Direct acting poppet structure	
Valve leakage cm ³ /min	10 or less	
Mounting	Flexible	
Port size (IN)	None	
Orifice mm	3	
C [dm ³ /(s·bar)] Note 1	1.2	
b	0.56	
Weight kg	0.25	
Electrical specifications		
Rated voltage	100VAC, 24VDC	
Rated voltage VA	50Hz	At holding: 7.5, at starting 20
	60Hz	At holding: 5.5, at starting 17
Power consumption W	50Hz	4
	60Hz	3.4
	DC	6.5
Heat proof class	B	

Note 1: Effective sectional area S and sonic conductance C are converted as $S \approx 5.0 \times C$.

How to order

CXU10-FAB3 - C6 - 2C - 3

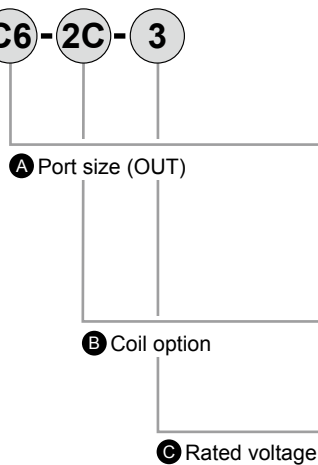

Symbol	Descriptions
A Port size (OUT)	
C6	ø6 push-in fitting
CL6	ø6 push-in fitting L type
C8	ø8 push-in fitting
CL8	ø8 push-in fitting L type
B Coil option	
2C	Grommet lead wire
2HS	DIN terminal box with light, surge suppressor (Pg11)
C Rated voltage	
1	100VAC 50/60Hz, 110VAC 60Hz
3	DC24V

⚠ Cautions for model No. selection

Note: Joiner set and a gasket included

Internal structure and parts list

● CXU10-FAB3

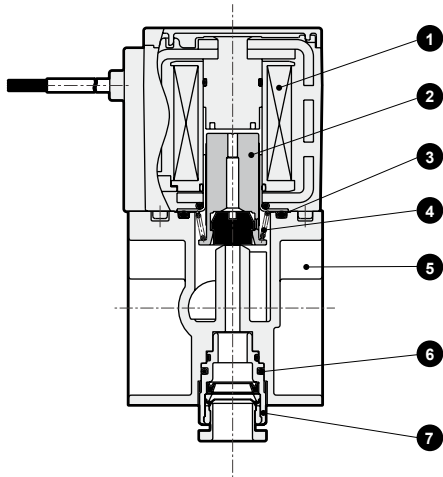

No.	Part name	Material	
1	Coil assembly	B class molded coil	
2	Plunger assembly	SUS, NBR	Stainless, nitrile rubber
3	O-ring	NBR	Nitrile rubber
4	Spring	SUS	Stainless steel
5	Body	PA66	Polyamide resin
6	Pin	SUS	Stainless steel
7	Fitting		

Dimensions

- Grommet lead wire type
CXU10-FAB3-*2C-*
Cartridge fitting: straight type

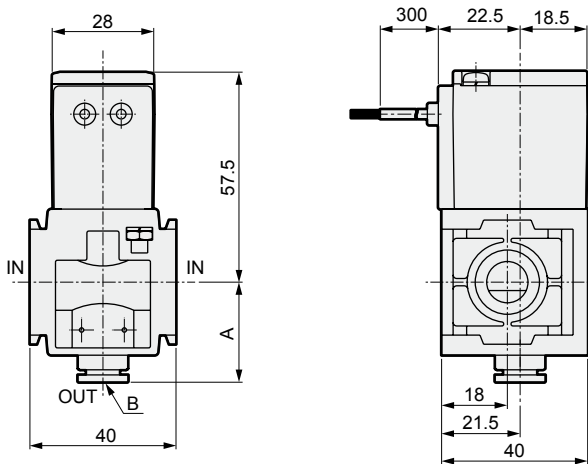

- With DIN terminal box (Pg7) type
CXU10-FAB3-*2HS-*

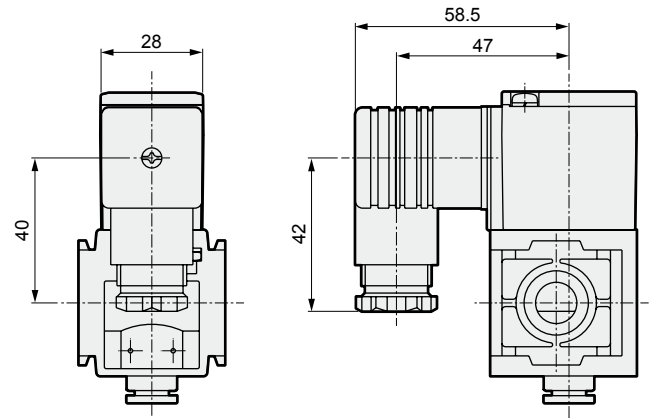

Elbow type fitting

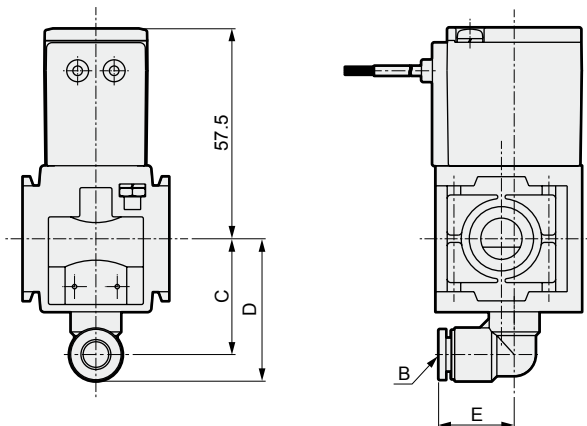

Option dimensions

Option	A	B	C	D	E
C6	27	ø6 push-in fitting	-	-	-
CL6	-	ø6 push-in fitting	31	37	18.5
C8	27	ø8 push-in fitting	-	-	-
CL8	-	ø8 push-in fitting	32	39	21



2 port direct acting solenoid valve

CXU30-FAB4U Series

NC (normally closed)

Modular connection with 3000 Series

Interchangeable with GFAB actuator assembly

JIS symbol

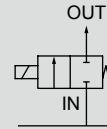

Screw free
open type

IN
Gasket

Expandable



Specifications

Descriptions		CXU30-FAB4U
Working fluid		Compressed air
Working pressure differential range MPa		AC: 0 to 1.0, DC: 0 to 0.9
Max. working pressure MPa		1
Withstanding pressure MPa		1.5
Fluid temperature °C		AC: 5 to 60, DC: 5 to 40
Ambient temperature °C		AC: 5 to 60, DC: 5 to 40
Atmosphere		Does not contact water, corrosive or flammable gas.
Valve structure		Direct acting poppet structure
Valve leakage cm ³ /min (ANR)		10 or less
Mounting		Flexible
Port size	IN	None
	OUT	Rc1/4
Orifice mm		4
C [dm ³ /(s·bar)] Note 1		2.1
b		0.34
Weight kg		0.55
Electrical specifications		
Rated voltage		100VAC, 24VDC
Rated voltage VA	50Hz	At holding: 15, at starting 40
	60Hz	At holding: 11, at starting 35
Power consumption W	50Hz	7.5
	60Hz	6.5
	DC	8
Heat proof class		B

Note 1: Effective sectional area S and sonic conductance C are converted as $S \approx 5.0 \times C$.

How to order

CXU30-FAB4U-8L-2C-3



A Coil option

B Rated voltage

Symbol	Descriptions
A Coil option	
2C	Grommet lead wire
2HS	DIN terminal box with light, surge suppressor (Pg11)
B Rated voltage	
1	100VAC 50/60Hz, 110VAC 60Hz
3	24VDC

⚠ Cautions for model No. selection

Note: Joiner set and a gasket included

Internal structure and parts list

● CXU30-FAB4U

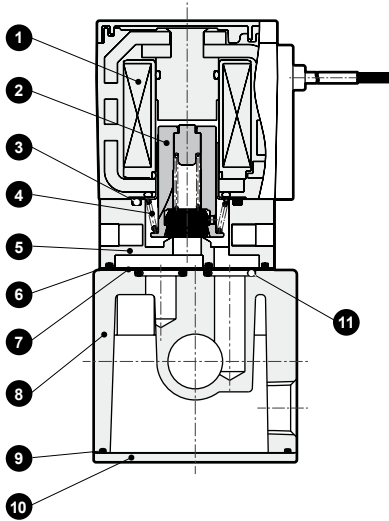

No.	Part name	Material	
1	Coil assembly	B class molded coil	
2	Plunger assembly	SUS, NBR	Stainless, nitrile rubber
3	O-ring	NBR	Nitrile rubber
4	Spring	SUS	Stainless steel
5	Body	PPS	Polyphenylene Sulfide
6	Gasket	NBR	Nitrile rubber
7	Plate	SUS	Stainless steel
8	Body	ADC12	Aluminum alloy die-casting
9	O-ring	NBR	Nitrile rubber
10	Bottom plate	SPCC	Steel sheet
11	O-ring	NBR	Nitrile rubber

Dimensions

● Grommet lead wire type CXU30-FAB4U-8L-2C-*

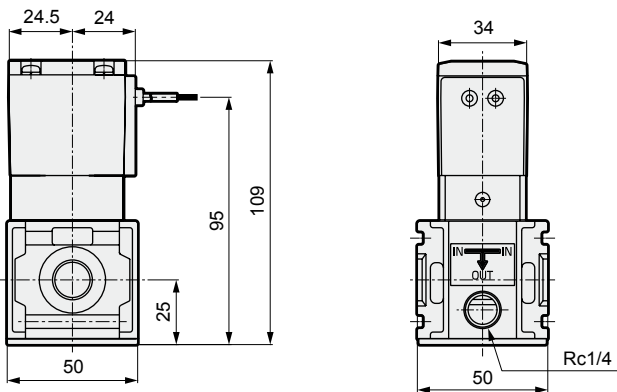

● With DIN terminal box (Pg7) CXU30-FAB4U-8L-2HS-*

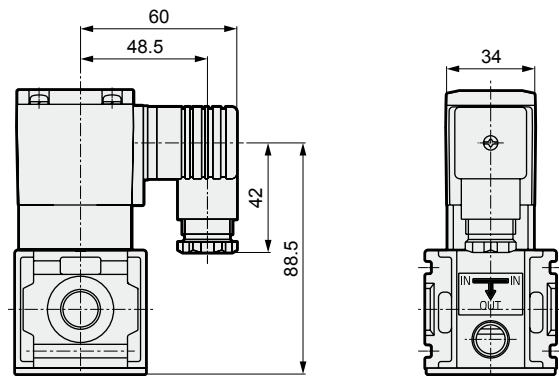



2 port pilot kick solenoid valve

CXU30-ADK Series

NC (normally closed)
 Diaphragm structure
 Modular connection with 3000 Series
 Suitable as modular component master valves

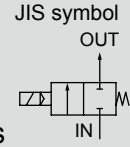

Module dedicated

RoHS

In line

Specifications

Descriptions	CXU30-ADK	
Working fluid	Compressed air	
Working pressure differential range MPa	AC: 0 to 1.0, DC: 0 to 0.7	
Max. working pressure MPa	2	
Withstanding pressure (water) MPa	4	
Fluid temperature (Note 1) °C	Nitrile rubber: -10 to 60, fluoro rubber: 5 to 60	
Ambient temperature °C	-10 to 60	
Atmosphere	Does not contact water, corrosive or flammable gas.	
Valve structure	Pilot kick poppet structure Diaphragm operated	
Valve leakage cm ³ /min	10 or less	
Mounting	Flexible	
Port size	None	
Orifice mm	12	
C [dm ³ /(s·bar)] Note 2	10.4	
b	0.46	
Weight kg	0.65	
Electrical specifications		
Rated voltage	100VAC, 24VDC	
Apparent power VA	50Hz	24
	60Hz	19
Power consumption W	50Hz	10
	60Hz	8
	DC	11
Heat proof class	B	

Note 1: To be unfrozen

Note 2: Effective sectional area S and sonic conductance C are converted as $S \cong 5.0 \times C$.

How to order

CXU30-ADK-00 - F 2C - 3

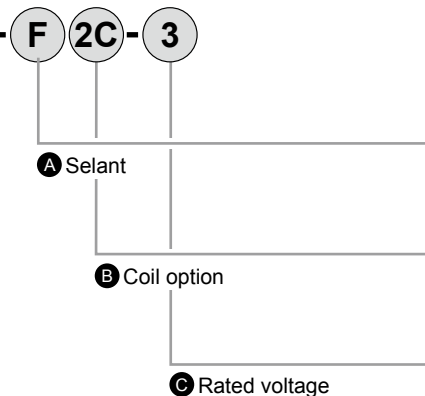

Symbol	Descriptions
A Selant	
Blank	Nitrile rubber
F	Fluoro rubber
B Coil option	
2C	Grommet lead wire *11
2HS	DIN terminal box with light, surge suppressor (Pg11)
C Rated voltage	
1	100VAC 50/60Hz, 110VAC 60Hz
3	24VDC

Note 1: Coil option 2C is available for rated voltage 【1】 only.

⚠ Cautions for model No. selection

Note: Joiner set included

Internal structure and parts list

● CXU30-ADK

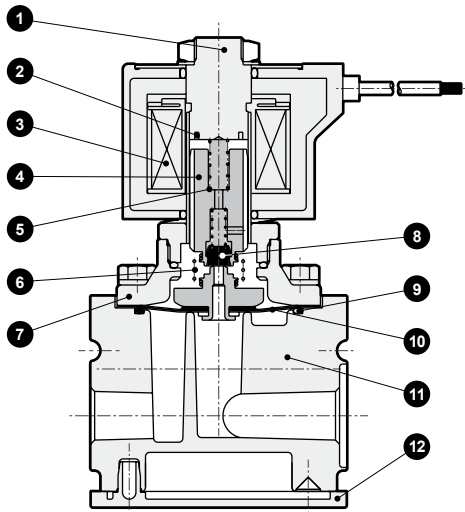

No.	Part name	Material	
1	Core assembly	SUS	Stainless steel
2	Shading coil	Cu	Copper
3	Coil	—	—
4	Plunger assembly	SUS	Stainless steel
5	Plunger spring	SUS	Stainless steel
6	Kick spring	SUS	Stainless steel
7	Stuffing	C	Bronze casting
8	Spring	NBR (FKM)	Nitrile rubber (fluoro rubber)
9	Diaphragm assembly	SUS·NBR (SUS·FKM)	Stainless steel·nitrile rubber (stainless steel·fluoro rubber)
10	O-ring	NBR (FKM)	Nitrile rubber (fluoro rubber)
11	Body	ADC	Aluminum alloy die-casting
12	Plate cover	ABS	ABS resin

Dimensions

● Grommet lead wire type CXU30-ADK-00-*2C-*

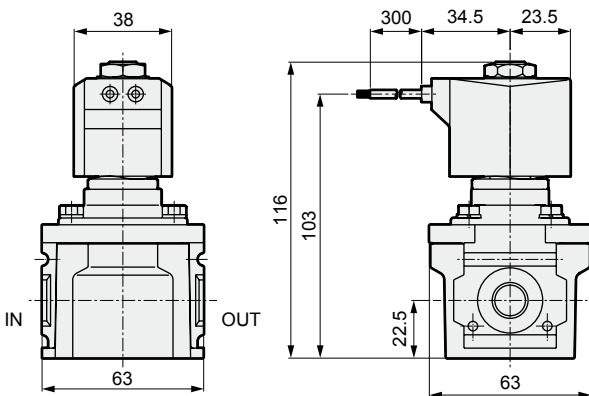

● With DIN terminal box (Pg7) type CXU30-ADK-00-*2HS-*

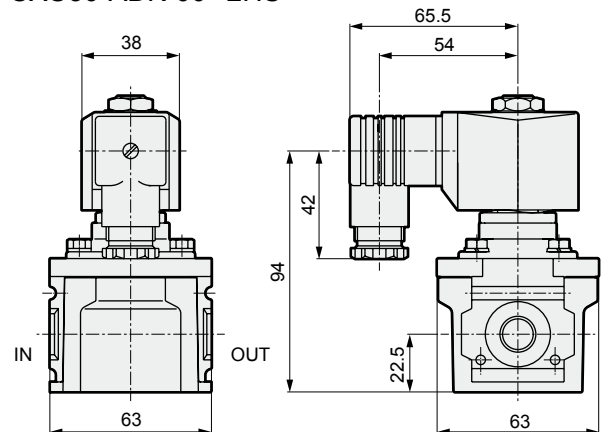

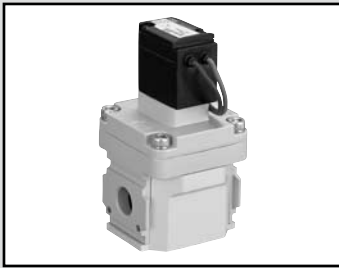

2 port pilot operated solenoid valve

CXU30-FAD Series

NC (normally closed)

Diaphragm structure

Modular connection with 3000 Series

Suitable as modular component master valves

JIS symbol

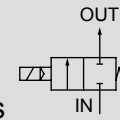

Screw free
open type

RoHS

In
line

Specifications

Descriptions	CXU30-FAD	
Working fluid	Compressed air	
Min. working pressure difference MPa	0.1	
Max. working pressure difference MPa	0.7	
Max. working pressure MPa	0.7	
Withstanding pressure MPa	1.4	
Fluid temperature °C	-10 to 60 (to be unfrozen)	
Ambient temperature °C	-10 to 60	
Atmosphere	Does not contact water, corrosive or flammable gas.	
Valve structure	Pilot operated diaphragm structure	
Valve leakage cm ³ /min (ANR)	10 or less	
Mounting	Flexible	
Port size	None	
Orifice mm	15	
C [dm ³ /(s·bar)] Note 1	18	
b	0.4	
Weight kg	0.5	
Electrical specifications		
Rated voltage	100VAC, 24VDC	
Apparent power VA	50Hz	7.5
	60Hz	5.5
Power consumption W	50Hz	4
	60Hz	3.4
	DC	6.5
Heat proof class	B	

Note 1: Effective sectional area S and sonic conductance C are converted as $S \approx 5.0 \times C$.

Note 2: Depending on use, such as using with an extremely small flow rate or when the solenoid valve's secondary side is restricted, operation may be unstable at pressure differences less than 0.1 MPa.

How to order

CXU30-FAD-00 - X1 - 2C - 3

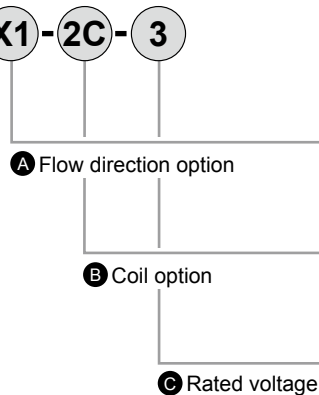

Symbol	Descriptions
A Flow direction option	
Blank	Standard flow (left to right)
X1	Reverse flow (right to left)
B Coil option	
2C	Grommet lead wire
2HS	DIN terminal box with light, surge suppressor (Pg11)
C Rated voltage	
1	100VAC 50/60Hz, 110VAC 60Hz
3	24VDC

⚠ Cautions for model No. selection

Note: Joiner set included

Internal structure and parts list

● CXU30-FAD

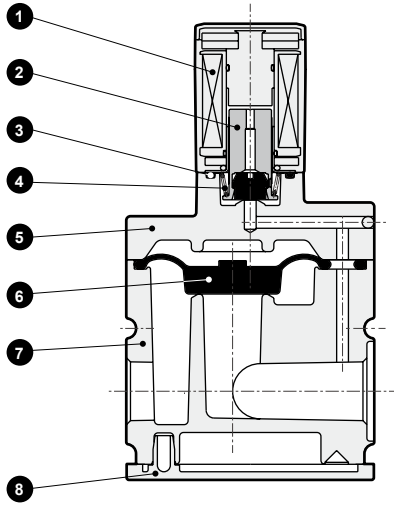

No.	Part name	Material	
1	Coil assembly	B class molded coil	
2	Plunger assembly	SUS, NBR	Stainless, nitrile rubber
3	O-ring	NBR	Nitrile rubber
4	Spring	SUS	Stainless steel
5	Stuffing	ADC	Aluminum alloy die-casting
6	Diaphragm	U	Urethane rubber resin
7	Body	ADC	Aluminum alloy die-casting
8	Plate cover	ABS	ABS resin

Dimensions

● Grommet lead wire type CXU30-FAD-00-*-2C-*

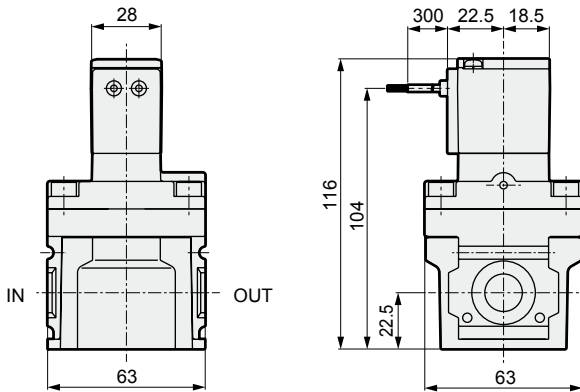

● With DIN terminal box (Pg7) type CXU30-FAD-00-*-2HS-*

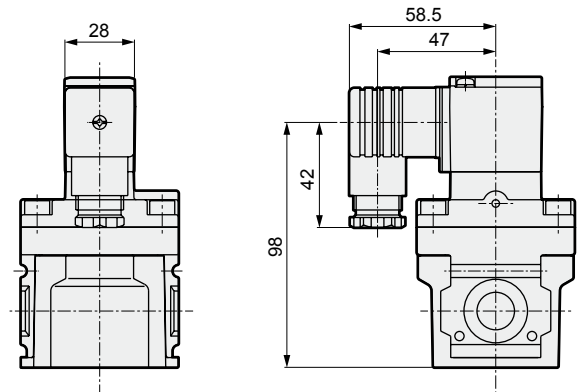

CXU30-FAD-00-X1-2C-*

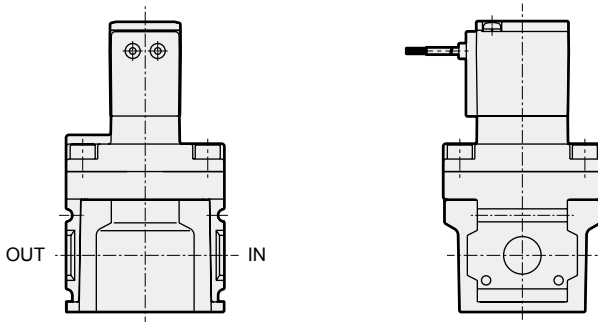

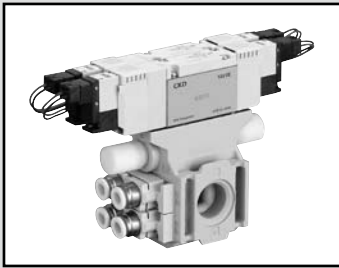

5 port pilot operated valve

CXU30-4G2 Series

5 port solenoid valve for modular connection with 3000 Series

Screw free
open type

IN
Gasket

Expandable



JIS symbol

2-position single solenoid

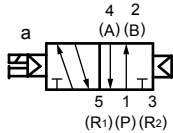

2-position double solenoid

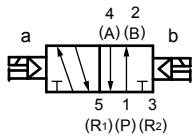

3-position all ports closed

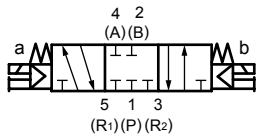

3-position ABR connection

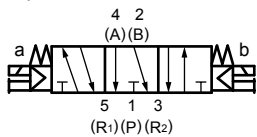

3-position PAB connection

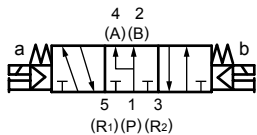

(e.g.) CXU30-4G2-13-C6-B-1

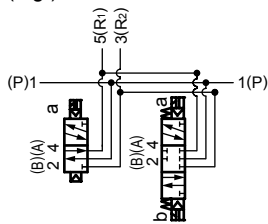

Common specifications

Descriptions		Descriptions
Type of valve / operation method		Pilot operated soft spool valve
Working fluid		Compressed air
Max. working pressure MPa		0.7
Min. working pressure MPa		0.2 (2 position, 3 position)
Withstanding pressure MPa		1.05
Fluid temperature °C		5 to 55
Ambient temperature °C		-5 to 55 (to be unfrozen)
Working environment		Does not contact water, corrosive or flammable gas.
Port size	A/B port	Push-in fitting $\varnothing 4$, $\varnothing 6$, $\varnothing 8$
	P port	None (connectable with 3000 Series)
	R1, R2 port	Rc1/4
Manual override		Locking/non-locking common type
Pilot exhaust method		Main valve, pilot valve common exhaust type
Lubrication	Note 1	Not required
Protective structure	Note 2	Dust proof
Vibration / impact	m/s ²	50 or less / 300 or less

Note 1: Use the turbine oil Class 1 ISO VG32 if lubricated.

Excessive or intermittent lubrication results in instable operation.

Note 2: Make sure water drops or oil, etc., do not come into contact.

IP65 (jet-proof type) is used for DIN terminal box specifications.

Note that the box must be fixed using the specified adaptive cord outer diameter and tightening torque.

Electrical specifications

Descriptions		Descriptions
Rated voltage	V DC	24
	V AC	100
Rated voltage fluctuation range		±10%
Holding current	A 24VDC	0.023 (0.025)
	Note 3 100VAC	0.010 (0.012)
Power consumption	W 24VDC	0.55 (0.6)
	Note 3 100VAC	0.55 (0.6)
Apparent power	VA 100VAC	1.0 (1.2)
Heat proof class		B
Temperature increase °C		50
Surge suppressor		Standard
With indicator		light (standard)

Note 3: Values in parentheses include light.

Weight

(unit: kg)

Solenoid position			Descriptions	
			Discrete valve	Valve sub-base
Without solenoid valve: masking plate			0.02	0.32
2-position	Single	E-connector	0.08	
		DIN terminal	0.1	
	Double	E-connector	0.1	
		DIN terminal	0.14	
3-position	All ports closed	E-connector	0.11	
		DIN terminal	0.15	

Weight: Discrete valve used ① + discrete valve ② + valve sub-base.

Flow characteristics

Solenoid position	P→A/B		A/B→R1/R2		
	C [dm ³ /(s·bar)]	b	C [dm ³ /(s·bar)]	b	
2-position	2.3	0.29	1.8	0.24	
3-position	All ports closed	2.1	0.27	2.3	0.27
	A/B/R connection	2.1	0.34	1.7	0.2
	P/A/B connection	2.2	0.34	2.4	0.29

Note 1 : Effective sectional area S and sonic conductance C are converted as $S \approx 5.0 \times C$.

Note 2 : The value for 2 position and ABR connection is the value when a check valve is integrated.

How to order

CXU30-4G2-3-3-C6-E20-S-3

A Model no.

B Solenoid valve ①, solenoid position Note 5, 6

C Solenoid valve ②, solenoid position Note 5, 6

D Port size (OUT)

E Electric connection

F Option

G Rated voltage

Symbol	Descriptions
B Solenoid valve ① solenoid position	
0	Without solenoid valve: masking plate
1	2-position single solenoid
2	2-position double solenoid
3	3-position all ports closed
4	3-position ABR connection
5	3-position PAB connection
C Solenoid valve ② solenoid position	
0	Without solenoid valve: masking plate
1	2-position single solenoid
2	2-position double solenoid
3	3-position all ports closed
4	3-position ABR connection
5	3-position PAB connection
D Port size (OUT)	
C4	ø4 push-in fitting
C6	ø6 push-in fitting
CL6	ø6 push-in fitting L (rear)
C8	ø8 push-in fitting
E Electric connection	
B	DIN terminal box (Pg7)
E20	E connector lead wire (500mm) with surge suppressor and light
F Option	
Blank	None
S	2 silencers (SLW-8S) included
G Rated voltage	
1	100VAC (rectified bridge integrated)
3	24VDC

⚠ Cautions for model No. selection

Note 1: The GWS*-8-S fitting can be mounted on the R1 port.

Note 2: Check valve is provided as standard. The check valve specifications are not available for the 3-position all ports closed or P/A/B connection.

Note 3: If port size, wire connection, option or voltage is different for solenoid valve ① ②, the product will be processed as a customized order.

Note 4: Joiner set and a gasket included

Note 5: Refer to dimensions drawings for positions of solenoid valves ①, ②.

Note 6: When masking plates are used for all solenoid valves, indicated for wire connection and rated voltage options must be left blank.

Refer to page 31 for solenoid valve model no. list.

CXU30-4G2 Series

Internal structure and parts list

- 2-position single solenoid
E connector type E

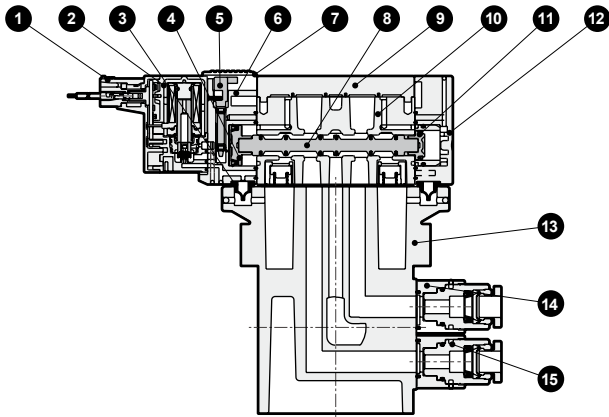

No.	Part name	Material
1	E connector socket assembly	—
2	Coil assembly	—
3	Pilot exhaust check valve	Nitrile rubber
4	Piston D assembly	—
5	Manual override	Resin
6	Piston room	Resin
7	Protective cover of manual override	Resin
8	Spool assembly	—
9	Plate	Resin
10	Body	Aluminum alloy die-casting
11	Piston S assembly	—
12	Cap	Resin
13	Modular sub-base qty.	Aluminum alloy die-casting
14	Fitting adaptor	Resin
15	Cartridge type push-in fitting	—
16	DIN terminal box assembly	—

- 2-position double solenoid
E connector type E

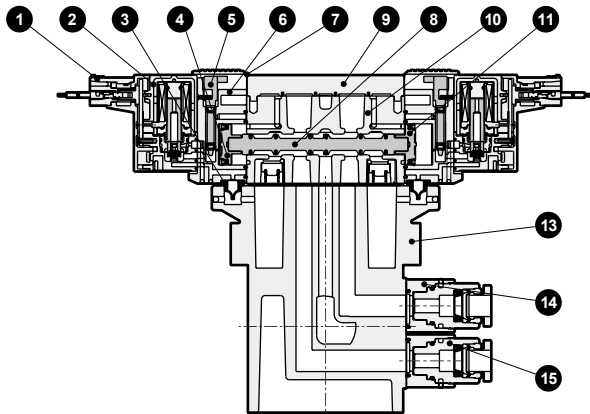

- 3-position
E connector type E

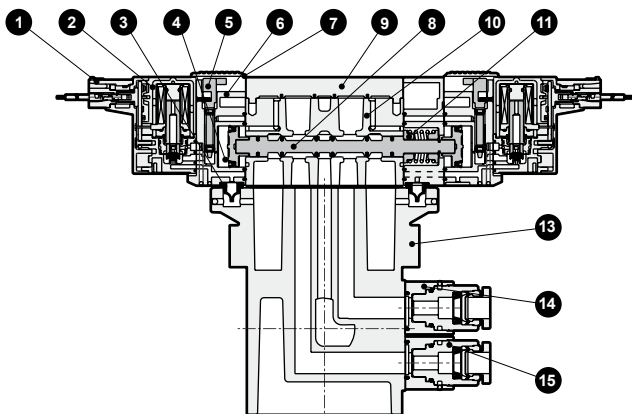

- DIN terminal box type B

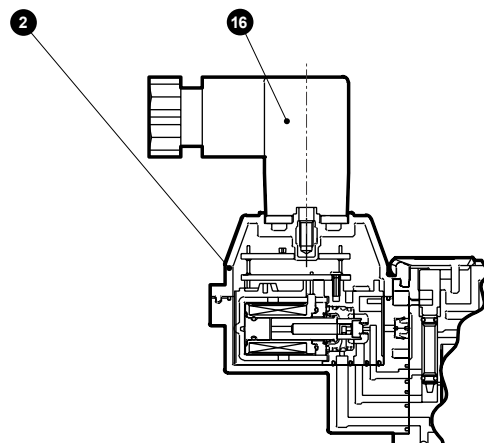

Dimensions

CXU30-4G2-0

- E connector type (E)
Cartridge fitting: Straight

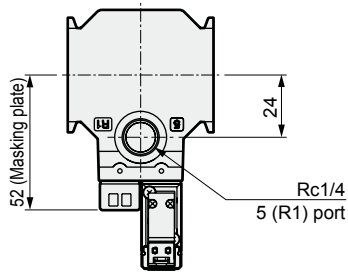

Note: Values in () apply for 100 VAC.

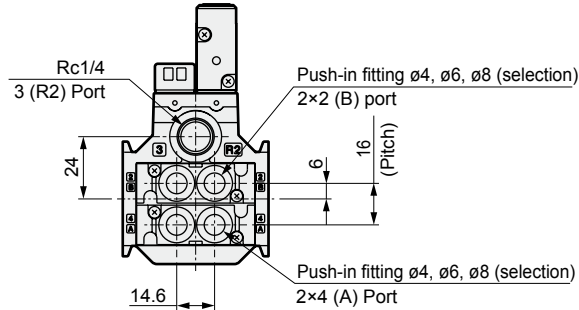
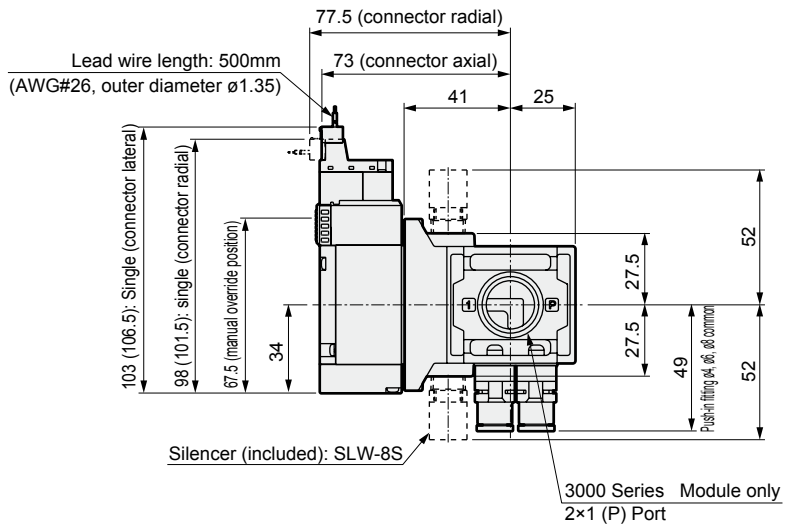
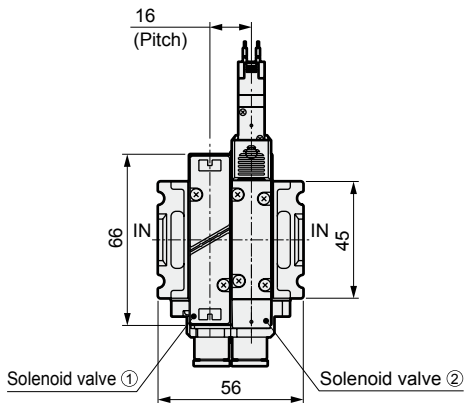

- DIN terminal box type (B)
Cartridge fitting: Straight

- ø6 push-in fitting L (rear)

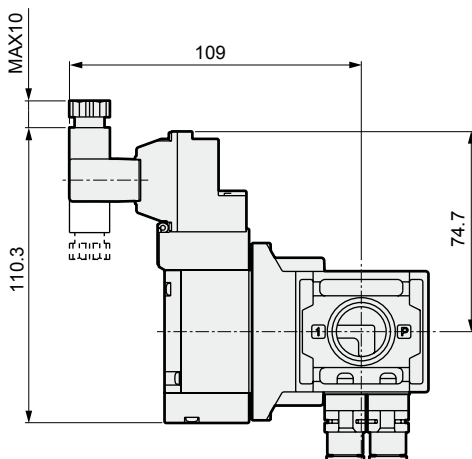

Note: The DIN terminal box assembly is shipped facing inward.

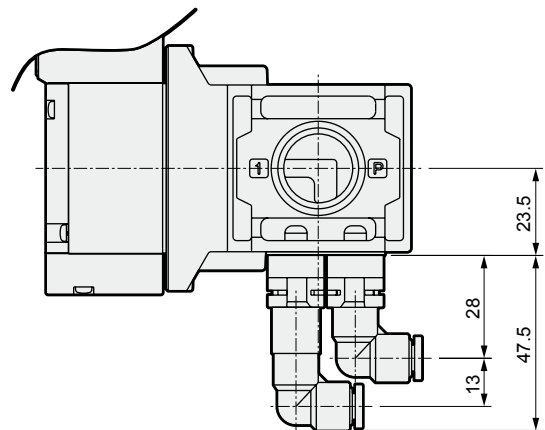

Valve air unit

Air unit component

Custom air unit

Handled as a custom order

CXU30-4G2 Series

Dimensions

CXU30-4G2-²/_{3 4 5}

- E connector type (E)
Cartridge fitting: Straight

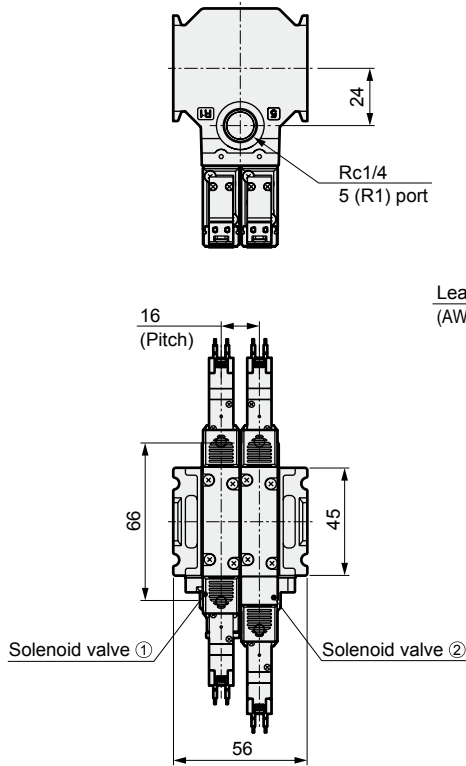

Note: Values in () apply for 100VAC.

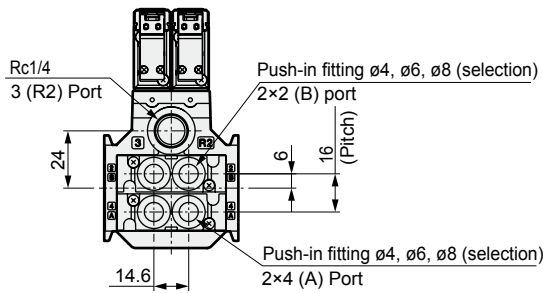
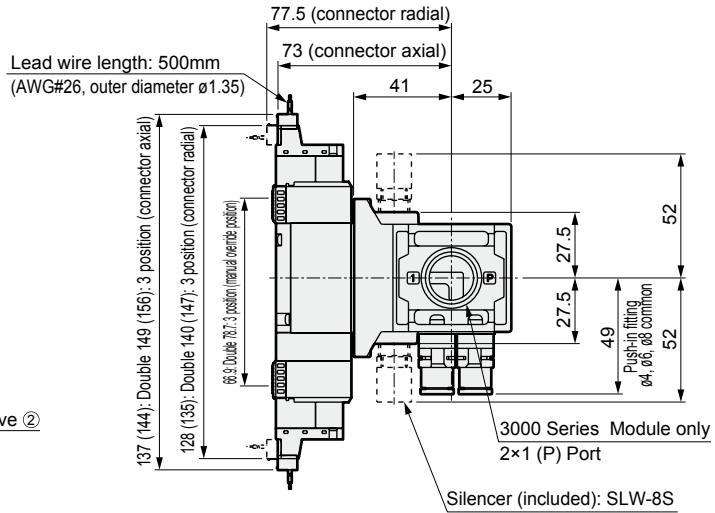

- DIN terminal box type (B)
Cartridge fitting: straight type

- ø6 push-in fitting L (rear)

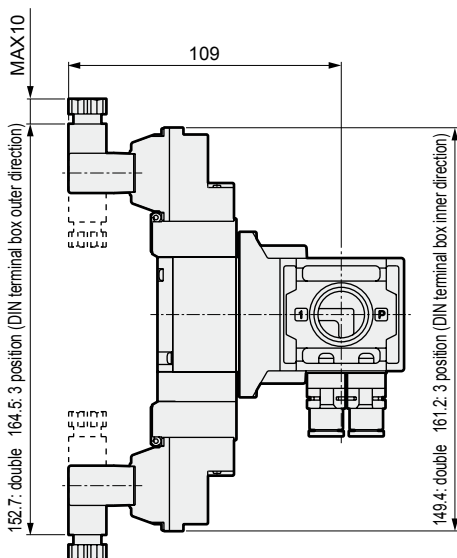

Note: The DIN terminal box assembly is shipped facing inward.

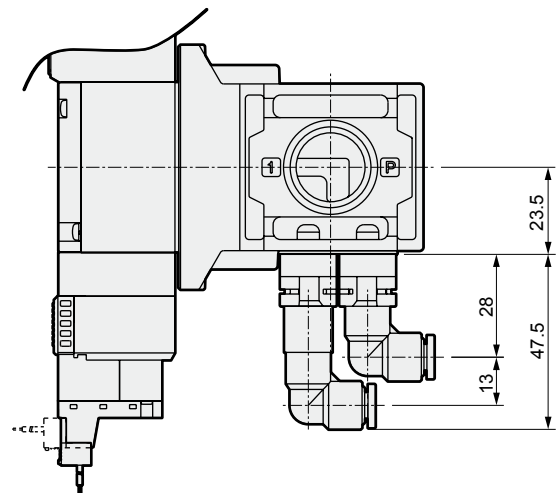

Solenoid valve model no. table

Solenoid valve switching position	Option		Solenoid valve no.
	Electric connection	Rated voltage	
0			4G2-MP
1	B	1	4GB219-00-BH-1
		3	4GB219-00-BH-3
	E20	1	4GB219-00-E20H-1
		3	4GB219-00-E20H-3
2	B	1	4GB229-00-BH-1
		3	4GB229-00-BH-3
	E20	1	4GB229-00-E20H-1
		3	4GB229-00-E20H-3
3	B	1	4GB239-00-B-1
		3	4GB239-00-B-3
	E20	1	4GB239-00-E20-1
		3	4GB239-00-E20-3
4	B	1	4GB249-00-BH-1
		3	4GB249-00-BH-3
	E20	1	4GB249-00-E20H-1
		3	4GB249-00-E20H-3
5	B	1	4GB259-00-B-1
		3	4GB259-00-B-3
	E20	1	4GB259-00-E20-1
		3	4GB259-00-E20-3

Valve air unit

Air unit component

Custom air unit

Handled as a custom order

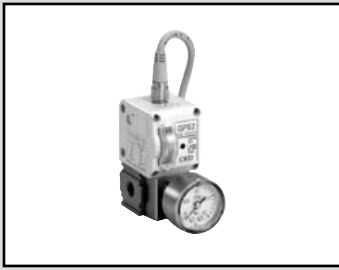

Contact confirmation switch (gap switch) discrete

GPS2 Series

● Port size: RC1/8 ● Nozzle size: $\phi 1.5$



How to order

GPS2 - 7 - 15 - N G TL S - B - G2

Gap switch

A Orifice

B Setting type

C Output type

D Light color

E Electric connection

F ISO compliance, etc.

Note 2

G Attachment and others

H Pressure gauge

Symbol	Descriptions
A Orifice	
5	$\phi 0.5$
7	$\phi 0.7$
B Setting type	
15	Dial detection nozzle diameter
C Output type	
N	NPN open collector
P	PNP open collector
D Light color	
G	Green
Y	Yellow
E Electric connection	
F	DIN terminal box (Pg11)
C0	Connector (without cable)
C1	Connector (1m cable included)
C3	Connector (3m cable included)
C5	Connector (5m cable included)
CTL	Connector type common terminal box Left
CTR	Connector type common terminal box Right
TL	Lead type common terminal box Left
TR	Lead type common terminal box Right
Lead wire for expanding terminal box type	
R	Lead wire outlet detection right (for left end mounting)
L	Lead wire outlet detection left (for right end mounting)
W	Lead wire outlet detection both sides (for intermediate mounting)
F ISO compliance, etc.	
S	CE marking
G Attachment and others	
Blank	No bracket
B	With bracket
L (Note 1)	With dial cover lock
H Pressure gauge	
Blank	Without pressure gauge
G2	Pressure gauge with safety mark included (G40D-8-P02-S501)
GW2	Pressure gauge with safety mark assembled (G40D-8-P02-S501)

⚠ Cautions for model No. selection

Note 1: Select L for automobile and processing machine related applications.

Note 2: The "D" light color is Y (yellow) for CE conformed parts.

Dimensions

● DIN terminal box type B

● GPS2-*-*-*F

(L: With dial cover lock)

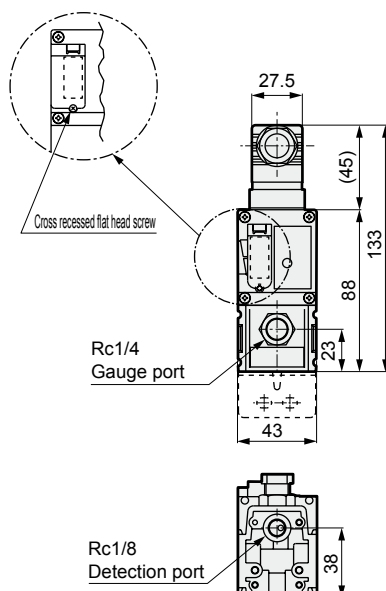

(L: With dial cover lock)

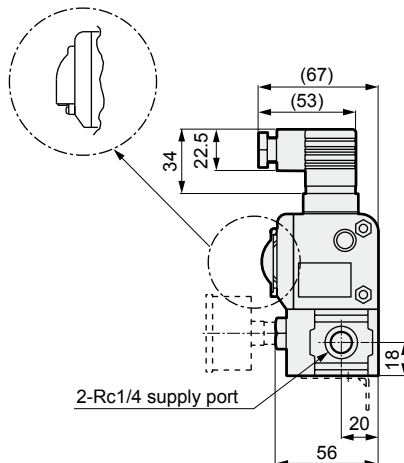

Dimensions

- Connector type
 - GPS2-**-**-**^{C0}
^{C1}
^{C3}
^{C5}

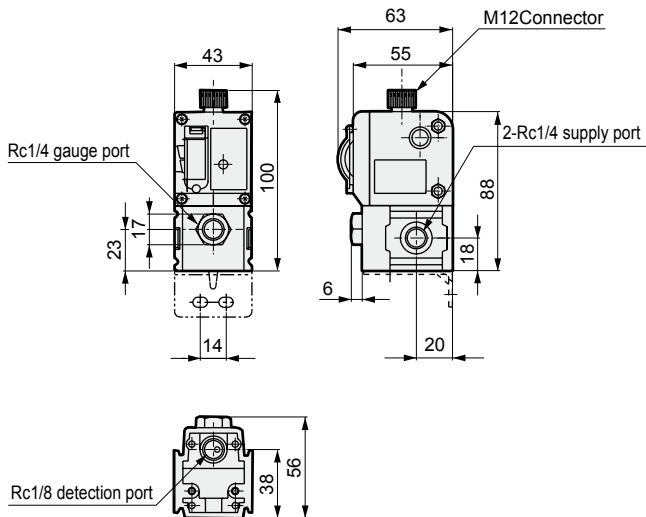

- Connector type common gland
 - GPS2-**-**-**^{CTL}
^(CTR)

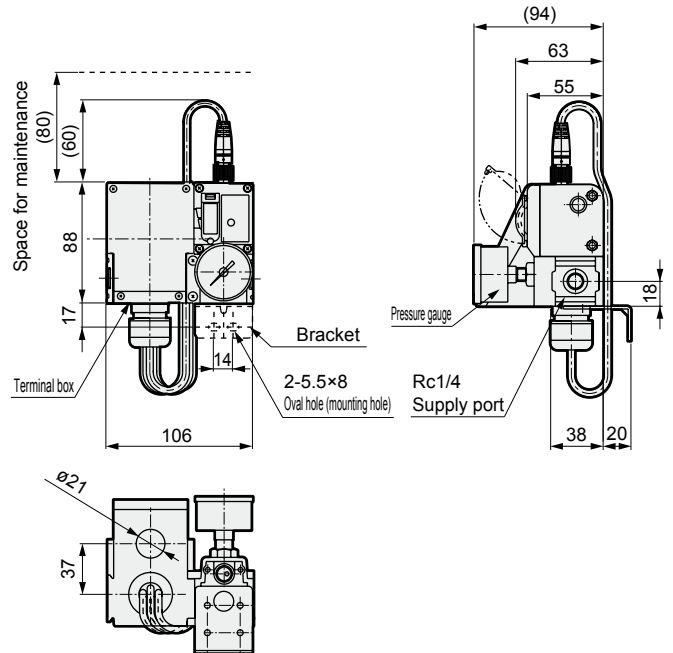

Note) The shape of the dial cover is different for models with dial cover lock. Refer to DIN terminal type on page 30 for its shape.

- Lead wire type common terminal box
 - GPS2-**-**-**^{TL}
^(TR)

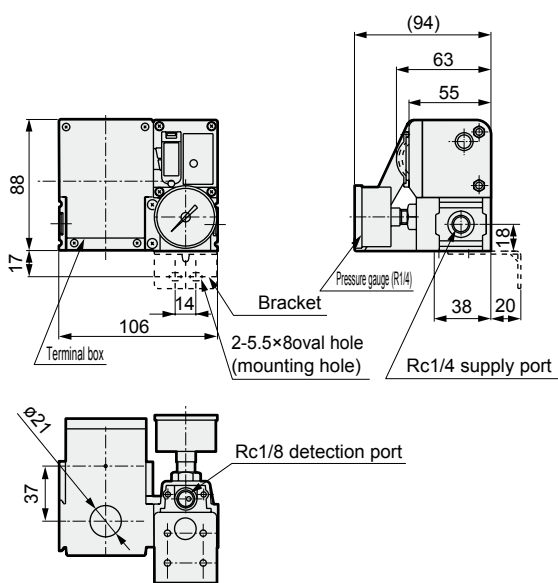

- Discrete model for expanding lead wire type common terminal box type
 - GPS2-**-**-**^R
^L
^W

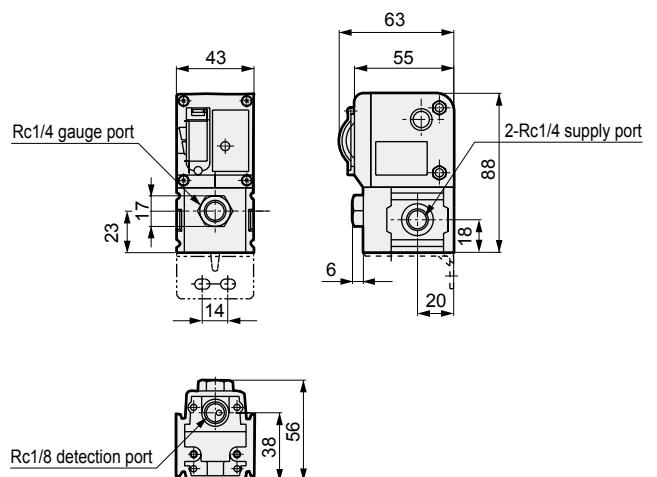

Note) The shape of the dial cover is different for models with dial cover lock. Refer to DIN terminal type on page 30 for its shape.

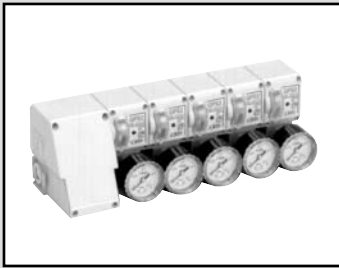

Gap switch manifold

MGPS2 Series

- Nozzle diameter: $\varnothing 1.5$ (Standard)
- Station no.: 2 to 5 stations



How to order gap switch manifold

MGPS2 - **7** - **15** - **2** **N** **Y** **TL** **S** - **B** - **G2**

Gap switch Manifold

A Orifice

B Setting type

C Station no.

D Output type

E Light color

F Electric connection

G ISO compliance, etc.

Note 2

H Attachment and others

I Pressure gauge

Symbol	Descriptions
A Orifice	
5	$\varnothing 0.5$
7	$\varnothing 0.7$
B Setting type	
15	Dial detection nozzle diameter
C Station no.	
2	2 stations
3	3 stations
4	4 stations
5	5 stations
D Output type	
N	NPN open collector
P	PNP open collector
E Light color	
G	Green
Y	Yellow
F Electric connection	
TL	Lead type common terminal box Left
TR	Lead type common terminal box Right
T1	Lead type common terminal box (1st from Left)
T2	Lead type common terminal box (2nd from Left)
T3	Lead type common terminal box (3rd from Left)
T4	Lead type common terminal box (4th from Left)
CTL	Connector type common terminal box Left
CTR	Connector type common terminal box Right
F	DIN terminal box (Pg11)
C0	Connector (without cable)
C1	Connector (1m cable included)
C3	Connector (3m cable included)
C5	Connector (5m cable included)
G ISO compliance, etc.	
S	CE marking
H Attachment and others	
Blank	No bracket
B	With bracket
L (Note 1)	With dial cover lock
I Pressure gauge	
Blank	Without pressure gauge
G2	Pressure gauge with safety mark included (G40D-8-P02-S501)
GW2	Pressure gauge with safety mark assembled (G40D-8-P02-S501)

Protective structure

Electric connection	Protective structure
T*	IP66 equivalent
CT*	IP67 equivalent
F*	IP64 equivalent
C*	IP67 equivalent

Note: This product must be used under the following conditions

- ① Piping and wiring completed and pressure applied.
- ② A waterproof bushing must be used on the wires to the terminal box.
- ③ A dial cover lock must be provided and the cover screw must be tightened.

⚠ Cautions for model No. selection

Note 1: Select L for automobile and processing machine related applications.

Note 2: The "D" light color is E (yellow) for CE conformed parts.

Terminal position mounting position diagram

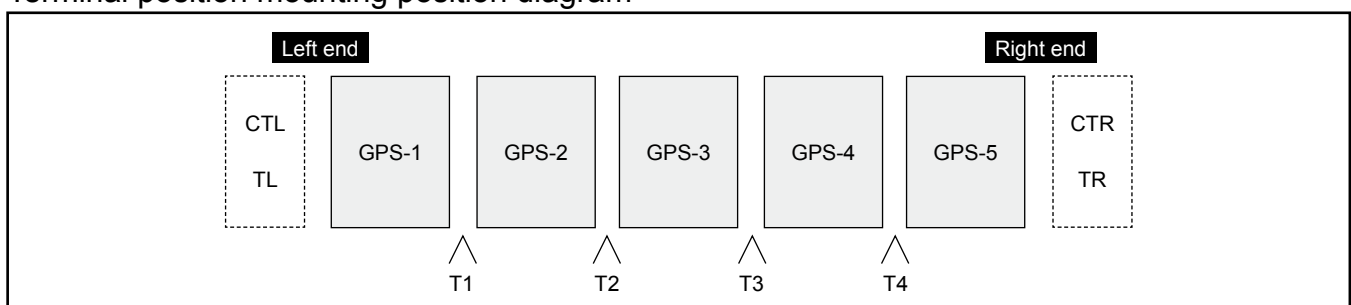

Dimensions

- Manifold type (Lead wire type common terminal box: TL, TR)
 - MGPS2-*_*-***^{TL}_(TR)

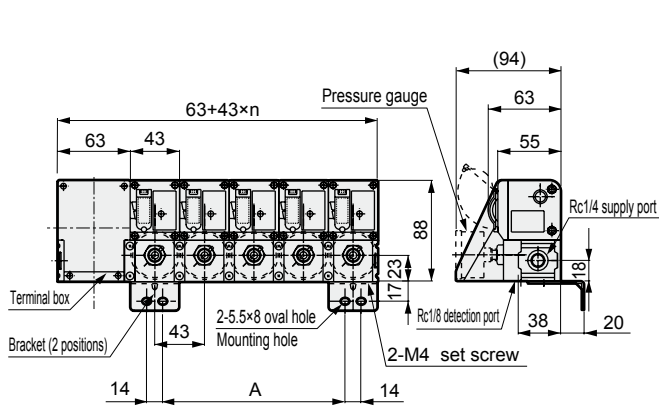

- Manifold type (Lead wire type common terminal box: TL, TR)
 - MGPS2-*_*-***^{CTL}_(CTR)

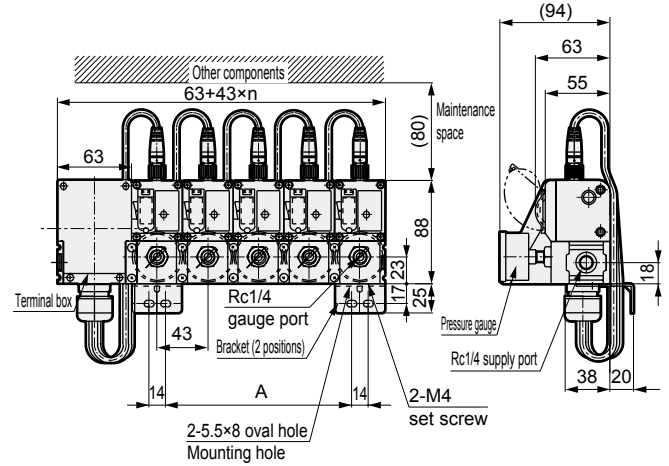

Station no.	n	A
2 stations	2	29
3 stations	3	72
4 stations	4	115
5 stations	5	158

Note) The shape of the dial cover is different for models with dial cover lock. Refer to DIN terminal type on page 30 for its shape.

- Manifold type (DIN terminal box: F)
 - MGPS2-*_*-***F

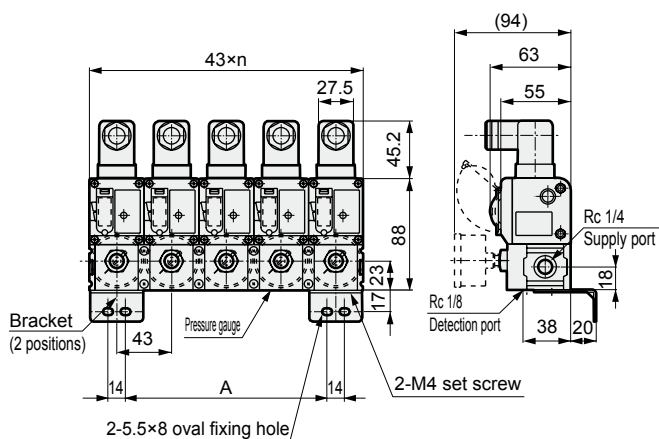

- Manifold type (connector: c*)
 - MGPS2-*_*-***^{C0}_{C1}^{C3}_{C5}

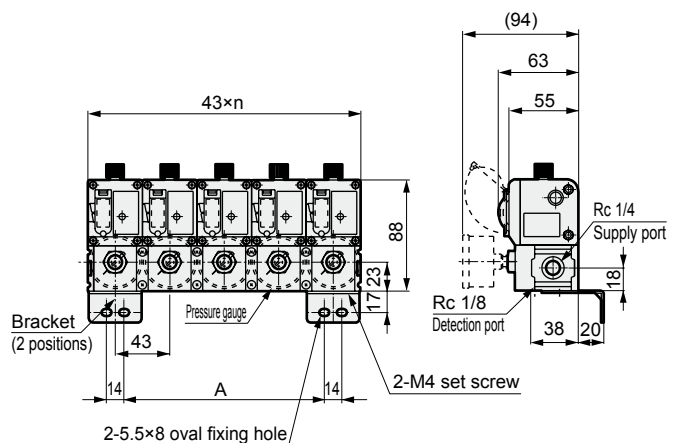

Station no.	n	A
2 stations	2	29
3 stations	3	72
4 stations	4	115
5 stations	5	158

Station no.	n	A
2 stations	2	29
3 stations	3	72
4 stations	4	115
5 stations	5	158

Note) The shape of the dial cover is different for models with dial cover lock. Refer to DIN terminal type on page 30 for its shape.

Valve air unit

Air unit component

Custom air unit

Handled as a custom order

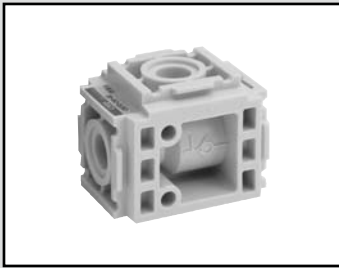

Modular check valve

CXU10-CHV Series

Completely blocks reverse flow of fluid such as compressed air
 Modular connection with F.R.L. 1000 Series
 Intermediate takeout of air possible with branch port

JIS symbol

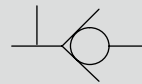

Specifications

Descriptions		Descriptions
Working fluid		Compressed air
Max. working pressure MPa		1
Min. working pressure MPa		0.03
Withstanding pressure MPa		1.5
Port size		None
Working temperature °C		5 to 60
Product weight kg		0.08
Effective sectional area	(IN→branching port) mm ²	28
	(IN→OUT) mm ²	28

How to order

CXU10-CHV - 0 - 6 - A

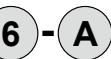

A Port size

B Option

Symbol	Descriptions	
A Port size		
Blank	Without piping adaptor	Note 1
6	Piping adaptor (Rc1/8") included	Note 2
8	Piping adaptor (Rc1/4") included	Note 2
10	Piping adaptor (Rc3/8") included	Note 2
MA	Masking adaptor included	Note 3
B Option		
Blank	No options	
A	Fluoro rubber specification	

⚠ Cautions for model No. selection

Note 1: A joiner set (joiner/bolt/O-ring) and a gasket are included as standard.

Note 2: A joiner set (joiner/bolt/O-ring) and 2 gaskets are included as standard.

Note 3: A masking adaptor and a joiner set (joiner/bolt/O-ring) and 1 gaskets are included as standard.

How to use



Internal structure and parts list

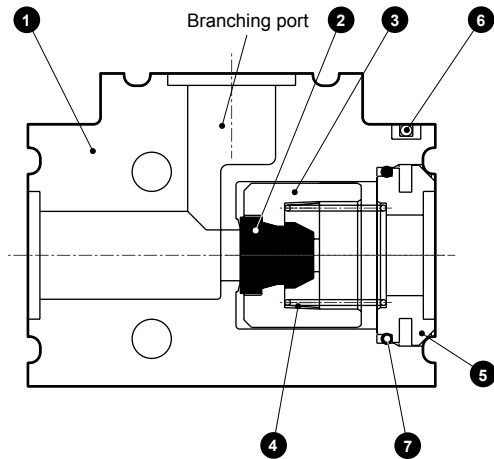

No.	Parts name	Material
1	Body	Polyamide
2	Valving element	Nitrile rubber (fluoro rubber)
3	Valve guide	Polyacetal
4	Coil spring	Stainless steel
5	Cover	Aluminum alloy
6	Stop pin	Stainless steel
7	O-ring	Nitrile rubber (fluoro rubber)

* The materials in () apply when option "A" is selected.

Dimensions

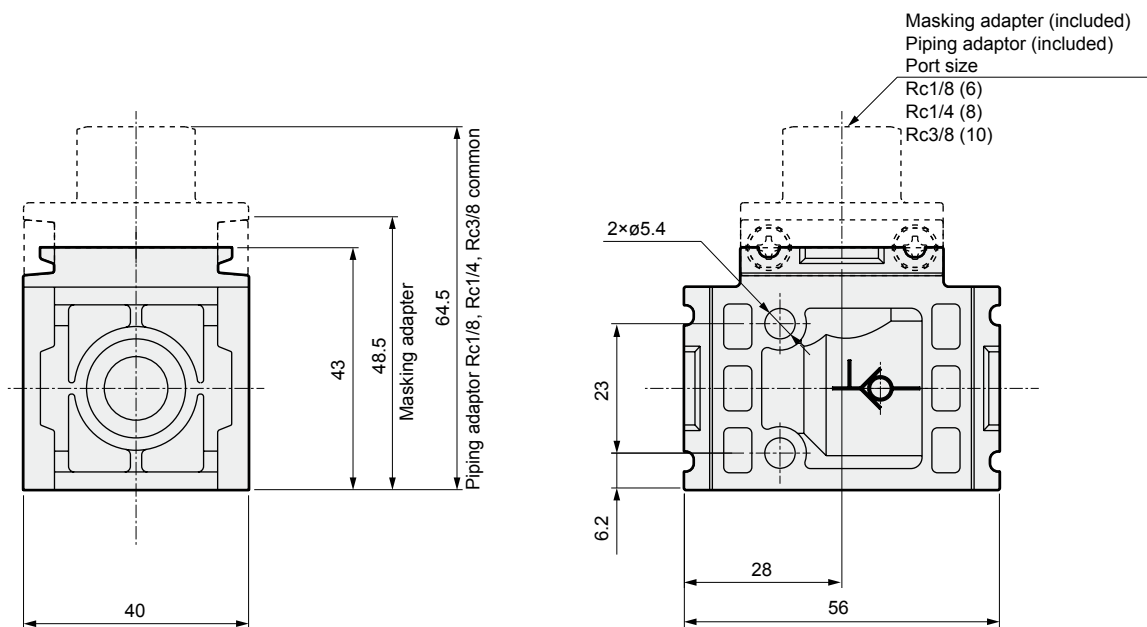

Safety precautions

CAUTION

- Pipe after confirming the JIS symbol of the product.

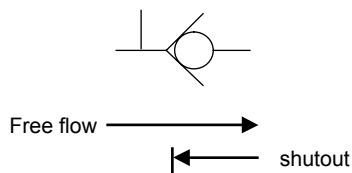

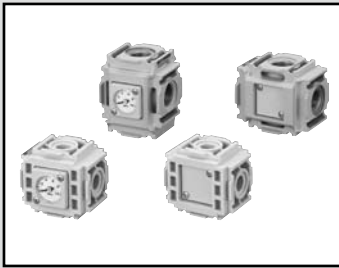

4 directional distributor

CXU10-D4·CXU30-D4 Series

Branches the joint section of a module in 4 directions.
 Joint section can be mounted and removed from 1 position.
 With pressure gauge mounting port.

Screw free
open type

RoHS

IN
Gasket

Specifications

Descriptions	CXU10-D4	CXU30-D4
Working fluid	Compressed air	
Max. working pressure MPa	1	
Withstanding pressure MPa	1.5	
Branching joint quantity	4	
Port size	None	Rc3/8, Rc1/2
Working temperature °C	5 to 60	
Product weight kg	0.1	0.3

How to use



How to order

CXU10-D4 - 00 - T6

JIS symbol



A Option

Symbol	Descriptions
A Option	
Blank	Without pressure gauge port (blanking plug assembled)
T6	Pressure gauge port Rc1/8
T8	Pressure gauge port Rc1/4
G401	With pressure gauge (G401)
R1	Pressure switch with display PPD assembled

How to order

CXU30-D4 - 15 - T6

JIS symbol

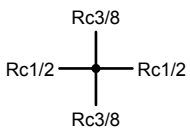

A Option

Symbol	Descriptions
A Option	
Blank	Without pressure gauge port (blanking plug assembled)
T6	Pressure gauge port Rc1/8
T8	Pressure gauge port Rc1/4
G401	With pressure gauge (G401)
R1	Pressure switch with display PPD assembled

⚠ Cautions for model No. selection

Note 1: The CXU30-D4 can be connected to the 2000/3000/4000 Series.

Note 2: There are four connections so the joiner set and gasket must be purchased and assembled separately.

Note 3: A joiner set (joiner/bolt/O-ring) and a gasket are included as standard.

CXU10-D4·CXU30-D4 Series

Internal structure·external dimensions

Internal structure and parts list

● CXU10-D4

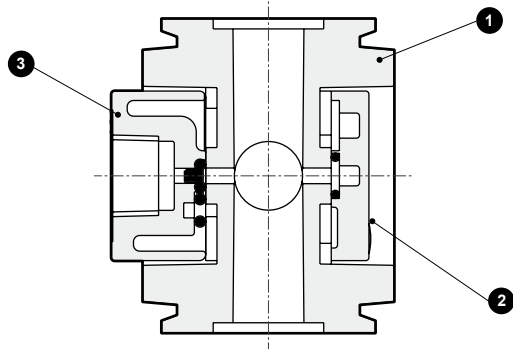

● CXU30-D4

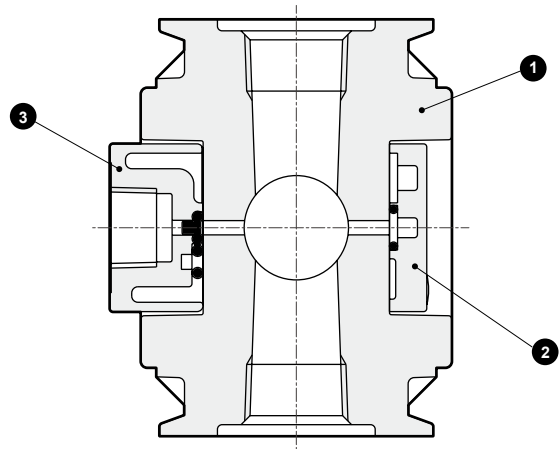

No.	Part name	Material	
		CXU10-D4	CXU30-D4
1	Body	Polyamide resin	Aluminum alloy die-casting
2	Blanking plug assembly	PBT resin, nitrile rubber, steel	
3	Gauge plug assembly	Polyamide resin, nitrile rubber, copper	
	Pressure gauge (G401)	PBT resin, nitrile rubber, polyacetal resin, polycarbonate resin, brass, steel	

Dimensions

● CXU10-D4

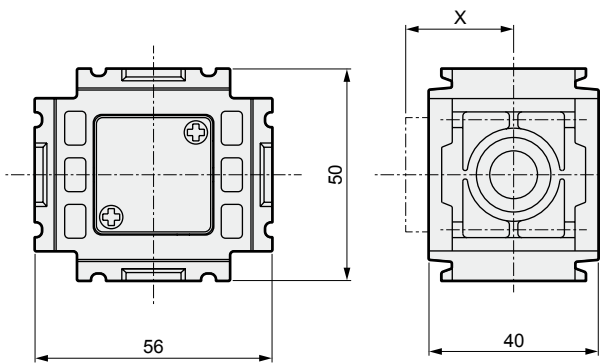

● CXU30-D4

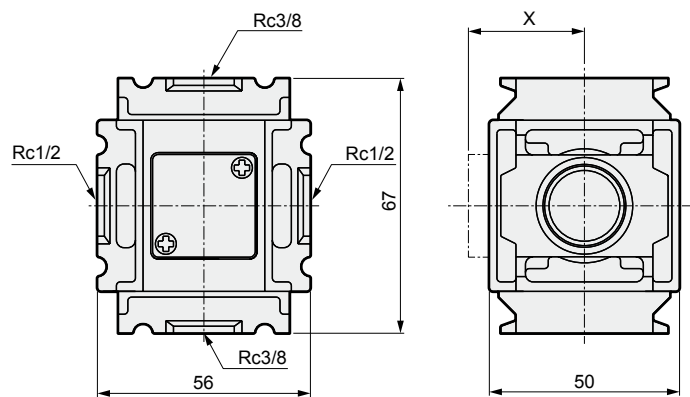

Option dimensions

Option	X
T6	25.5
T8	25.5
G401	25.5
R1	40

Option dimensions

Option	X
T6	30.5
T8	30.5
G401	30.5
R1	45

Valve air unit

Air unit component

Custom air unit

Handled as a custom order

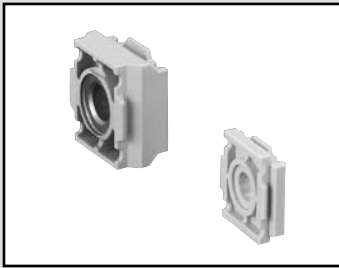

Turn adapter

CXU10-TA·CXU30-TA Series

Changes the joint section of a module in 90 directions.
Changes the direction of modular component.

Screw free
open type

RoHS

IN
Gasket

Specifications

Descriptions	CXU10-TA	CXU30-TA
Working fluid	Compressed air	
Max. working pressure MPa	1	
Withstanding pressure MPa	1.5	
Port size	None	
Working temperature °C	5 to 60	
Product weight kg	0.03	0.12

How to use



How to order

CXU10 - TA - 00

A Model no.

Symbol	Descriptions
A Model no.	
CXU10	1000 Series
CXU30	3000 Series

⚠ Cautions for model No. selection

Note 1: The CXU30-TA can be connected to the 2000/3000/4000 Series.

Note 2: A joiner set (joiner/bolt/O-ring) and a gasket are included as standard.

Internal structure and parts list

● CXU10-TA

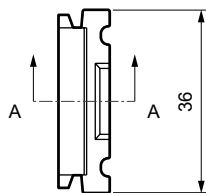

Top

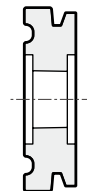

Cross section A-A

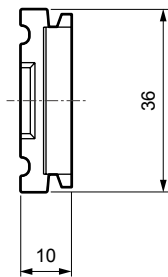

Front

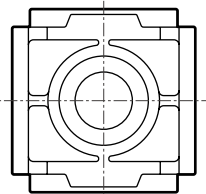

Side

● CXU30-TA

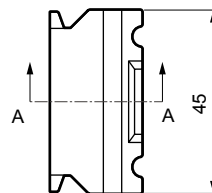

Top

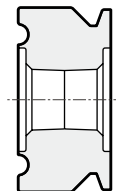

Cross section A-A

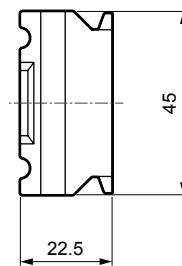

Front

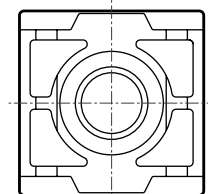

Side

No.	Part name	Material	
		CXU10-TA	CXU30-TA
1	Body	Polyamide resin	Aluminum alloy die-casting

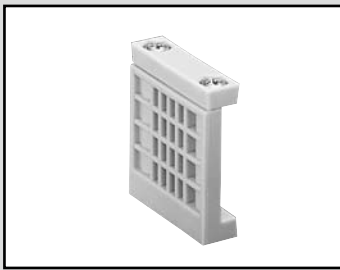

Masking adapter

CXU10-MA Series

Used for masking on the joint section of 1000 Series.



Specifications

Descriptions	CXU10-MA
Working fluid	Compressed air
Max. working pressure MPa	1
Withstanding pressure MPa	1.5
Port size	None
Working temperature °C	5 to 60
Product weight kg	0.02

How to use



How to order

CXU10-MA - 00 - B

A Option

Symbol	Descriptions
A Option	
Blank	Joiner
B	T type bracket (B110-W)
BH	T type bracket (B110-H-W)

⚠ Cautions for model No. selection

Note 1: 1 O ring included.

Note 2: Hexagon nut for fixing the T type bracket is included with the T type bracket.

Internal structure and parts list

● CXU10-MA

Option: Blank

Option: B, BH

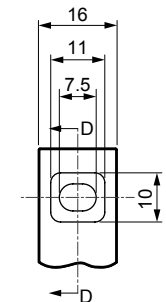
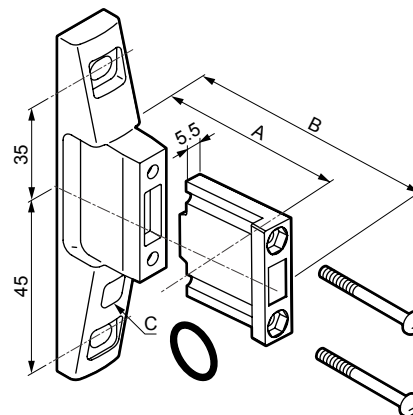
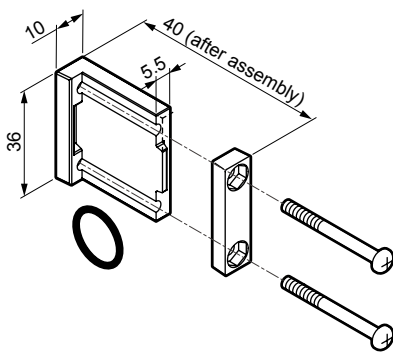

Bracket section details

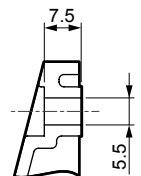

Cross section DD

Option dimensions

Option	A	B	C
B	40	60	-
BH	45	65	I.D. "H"

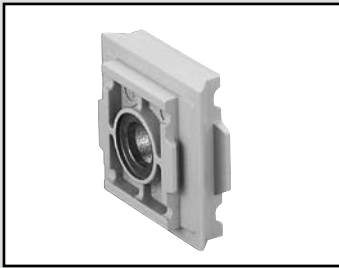

Module transform adaptor

CXU13-CA Series

Connectable with 1000, 2000, 3000, 4000 Series

Screw free
open type

RoHS

IN
Gasket

Specifications

Descriptions	CXU13-CA
Working fluid	Compressed air
Max. working pressure MPa	1
Withstanding pressure MPa	1.5
Port size	None
Working temperature °C	5 to 60
Product weight kg	0.04

How to use



How to order

CXU13-CA - 00

Note: The CXU13-CA can be connected to the 2000/3000/4000 Series.
A C1000-J100, C4000-J400 joiner set and gasket included.

Internal structure and parts list

● CXU13-CA

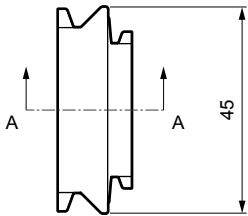

Top

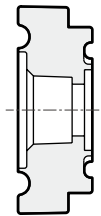

Cross section A-A

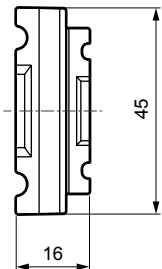

Front

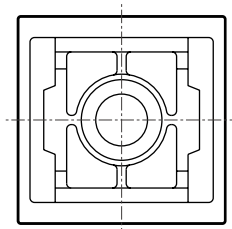

Side

No.	Part name	Material
1	Body	Aluminum alloy die-casting

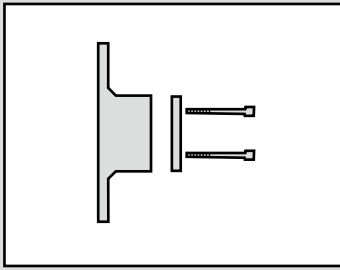

Bracket, joiner

B-W·J-W Series

O ring, gasket, pipe plug

ORING, GASKET, CXU-PP Series



Dimensions and applications

T type bracket set

● Model no.: B110-W·B110-H-W·B310-W·B410-W

● Applications

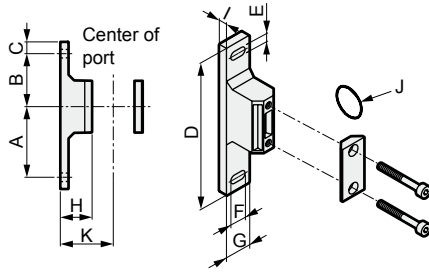

Note: By using B110-H-W, 1000 Series can be adjusted to the same height as 3000 Series.

Model no.	Applicable model	A	B	C	D	E	F	G	H	I	J	K
B110-W	1000 Series	45	35	10	100	5.5	2	16	25	7	JASO-2013	40
B110-H-W	1000 Series	45	35	10	100	5.5	2	16	30	7	JASO-2013	45
B310-W	2000 Series	60	45	10	125	7	7	22	27	7	JISB2401-P21	45
	3000 Series											
B410-W	4000 Series	60	45	10	125	7	7	22	37	7	JISB2401-P21	55

Fitting set

● Model no.: C1000-J100-W
C4000-J400-W

● Applications

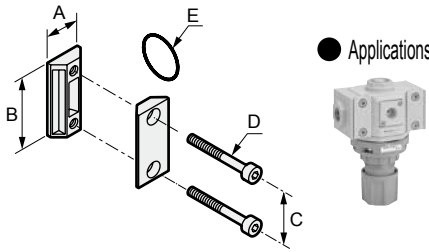

Model no.	Applicable model	A	B	C	D	E
C1000-J100-W	1000 Series	10	36	26	M3.5	JASO-2013
C4000-J400-W	2000 Series	21	44	32	M5	JIS B2401-P21
	3000 Series					
	4000 Series					

O ring, gasket

Material: NBR

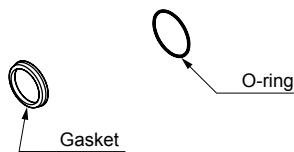

Model no.	Applicable model	Standards
C1000-ORING	1000 Series	JASO-2013
C1000-GASKET		CKD only
C4000-ORING	2000 Series	JIS B2401-P21
	3000 Series	
C4000-GASKET	4000 Series	CKD only

Sold in sets of 5 pieces.

Pipe plug

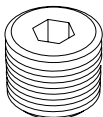

Material: steel

Model no.	Thread standards
CXU-PP-6	R1/8
CXU-PP-8	R1/4
CXU-PP-10	R3/8
CXU-PP-15	R1/2

Note: Banana plugs are sold in sets of 5.

Custom unit

Model no. for custom combinations



General Description

Complicated pneumatic components can be constructed by purchasing customized units. This eliminates bothersome piping, and enables immediate use.

Features

- ① Versatile combinations
Versatile layouts reduce the labor hours required for design.
- ② Simplified order form
The CXU can be ordered with only 1 form, making purchasing and delivery management easy.
- ③ Reduce man-hours
The FR component and solenoid valve are connected as modules, eliminating work such as piping.
- ④ Low profile
Piping free, fitting free sleek design. Ideal for use in limited space.
- ⑤ Front access
Easy to expand, mount and remove from the front. Great for maintenance as well.

Description of icons

- ① Model no. for custom order only.
 Model no. that includes -UN is for custom combinations only. Can not be purchased individually.
- ② Face to face dimensions
 Face to face dimensions are shown in the icon.
- ③ Can not be used at terminals
 Since there is no connection screw is provided, a masking adapter or piping adapter is required for use at the terminal.

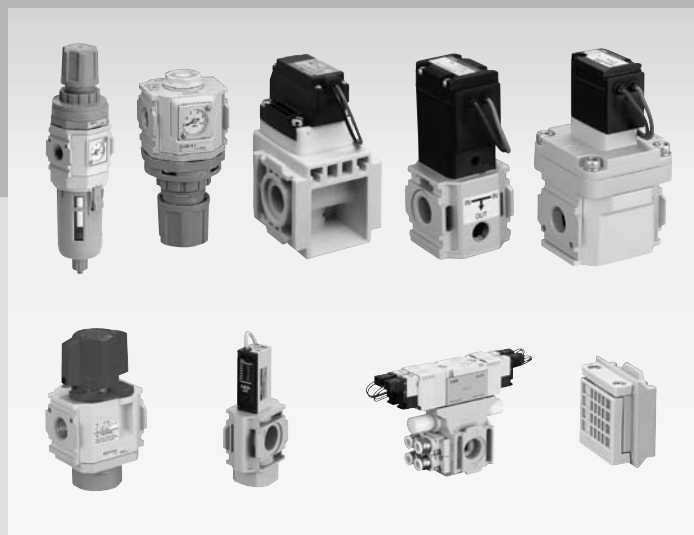

CONTENTS

<F.R.L components, solenoid valve>

- Filter·regulator
- Reverse filter·regulator
- Air filter
- Oil mist filter
- High performance oil mist filter
- Regulator
- Reverse regulator
- Lubricator
- Mechanical pressure switch
- Shut-off valve
- 2 port direct acting solenoid valve
- 2 port pilot kick solenoid valve
- 2 port pilot operated solenoid valve
- 5 port pilot operated valve

<Distributor, adaptor>

- Modular check valve
- Distributor















- Piping adaptor
- L type piping adaptor
- Masking adaptor

<Bracket, joiner>





- Joiner
- T type bracket

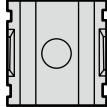

<F.R.L. components, solenoid valve>

Series	Model no.	Module		Port size (OUT)						Page	
		1000 Series	3000 Series	ø4	ø6	ø8	1/8	1/4	3/8		1/2
● Filter·regulator 	W1000	●					●	●			54
	NEW W2000		●					●	●		
	W3000		●					●	●		
	W4000		●					●	●	●	
● Reverse filter·regulator 	W1100	●					●	●			56
	NEW W2100		●					●	●		
	W3100		●					●	●		
	W4100		●					●	●	●	
● Air filter 	F1000	●					●	●			58
	NEW F2000		●					●	●		
	F3000		●					●	●		
	F4000		●					●	●	●	
● Oil mist filter 	M1000	●					●	●			60
	NEW M2000		●					●	●		
	M3000		●					●	●		
	M4000		●					●	●	●	
● High performance oil mist filter 	MX1000	●					●	●			62
	MX3000		●					●	●		
	MX4000		●					●	●	●	
● Regulator 	R1000	●					●	●			64
	R2000		●					●	●		
	R3000		●					●	●		
	R4000		●					●	●	●	
● Reverse regulator 	R1100	●					●	●			66
	R2100		●					●	●		
	R3100		●					●	●		
	R4100		●					●	●	●	
● Lubricator 	L1000	●					●	●			68
	L3000		●					●	●		
	L4000		●					●	●	●	
● Mechanical pressure switch 	P1100	●					●	●			70
	P4000		●					●	●	●	
	P4100-UN		●					●	●	●	
● Shut-off valve 	V1000	●					●	●			72
	V3000		●					●	●	●	
	V3010		●					●	●	●	
● 2 port pilot operated solenoid valve 	NEW CXU10-EXA-UN	●				●	●				74
● 2 port direct acting solenoid valve 	CXU10-FAB3-UN	●				●	●				75
	CXU30-FAB4U-UN		●					●			76
● 2 port pilot operated solenoid valve 	NEW CXU30-ADK-UN		●								77
	CXU30-FAD-UN		●								78
● 5 port pilot operated valve 	CXU30-4G2-UN		●	●	●	●					79

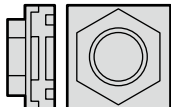
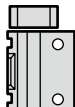
<Distributor, adaptor>

Series	Model no.	Module		Port size (OUT)						Page
		1000 Series	3000 Series	ø6	ø8	1/8	1/4	3/8	1/2	
<ul style="list-style-type: none"> ● Modular check valve 	<ul style="list-style-type: none"> ● NEW CXU10-CHV-UN 	●								82
<ul style="list-style-type: none"> ● Distributor 	D101-UN	●				●	●			83
	D401-UN		●				●	●	●	
	D300		●				●	●		
<ul style="list-style-type: none"> ● 4 directional distributor 	CXU10-D4-UN	●								84
	CXU30-D4-UN		●					●	●	
<ul style="list-style-type: none"> ● Piping adaptor 	A100-UN	●				●	●	●		85
	A400-UN		●				●	●	●	
<ul style="list-style-type: none"> ● L type piping adaptor 	A101-UN	●				●	●			85
	A401-UN		●				●	●	●	
<ul style="list-style-type: none"> ● Masking adapter 	CXU10-MA-UN	●								86
	CXU30-MA-UN		●							
<ul style="list-style-type: none"> ● Module transform adaptor 	CXU13-CA-UN		●							87

<Bracket, joiner>

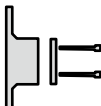
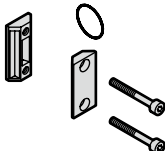
Series	Model no.	Module		Height to pipe center			Page
		1000 Series	3000 Series	40	45	55	
<ul style="list-style-type: none"> ● T type bracket set  <p>Note: T bracket sets of different height can not be combined.</p>	B110-UN	●		●			88
	B110-UN-H	●			●		
	B310-UN		●		●		
	B410-UN		●			●	
<ul style="list-style-type: none"> ● Joiner 	C1000-J100-UN	●					88
	C4000-J400-UN		●				

Valve air unit

Air unit component

Custom air unit

Handled as a custom order

Example of CXU10 Series custom combination specifications

1000 Series base

General Description

Customized combinations are customer-oriented combinations that meet user needs for diverse combinations. Place orders by filling out the specifications below.

More solenoid valve types, etc., are available than the conventional customized combinations.

Preparing custom combination specifications

- ① Indicate the full model in the model field for the required model.
- ② Indicate the installation position of the indicated model with a "○".
Indicate "UP" or "DOWN" for the orientation.
- ③ Indicate a "○" in the bracket and joiner fields.
- See individual pages for component ordering and details, etc.

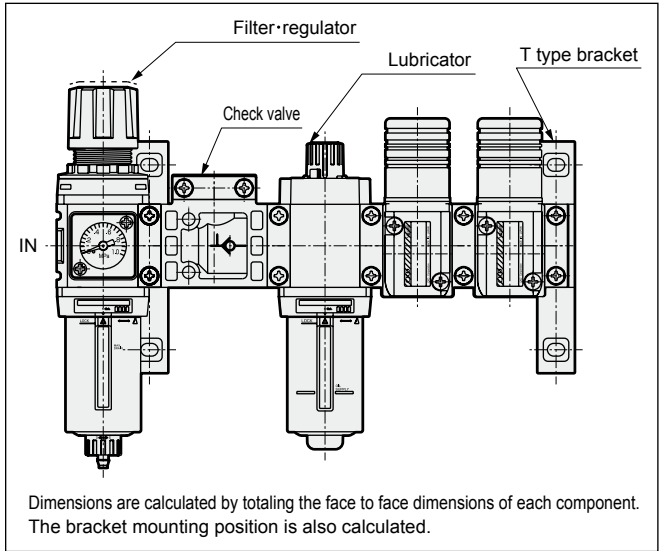

CXU10 Series custom combination specifications

1000 Series base

Contact _____	Quantity _____ sets	Issue _____
Slip no. _____	Request date _____	Your company name _____
		Contact _____
		Order no. _____

● Model no. **CXU10 – UN –**

Leave it blank.
CKD control no.

Flow direction	Left→Right	Right→Left
Blank	<input type="checkbox"/>	<input type="checkbox"/>
X1	<input type="checkbox"/>	<input type="checkbox"/>

Designate the direction of compressed air flow as seen from the front. Leave blank when no symbol is selected.

★For products with an asterisk (*), indicate up/down. Indicate up/down for the regulator's knob direction, and the port up/down direction for other components.

Indicate the installation position in order from the left as seen from the front.

Part name:	Face to face dimensions	Model no.	Direction	Mounting position					Field for Engineers
Filter-regulator	40	W1000-8-W W1100-		<input type="checkbox"/>					
Air filter	40	F1000-							
Oil mist filter	40	M1000-							
High performance oil mist filter	40	MX1000-							
Regulator*	40	R1000-							
	40	R1100-							
Lubricator	40	L1000-8-W			<input type="checkbox"/>				
Pressure switch	28	P1100-UN-	*2						*2
Shut-off valve	40	V1000-							
2 port pilot operated solenoid valve	40	CXU10-EXA-UN-	*2						*2
2 port direct acting solenoid valve	40	CXU10-FAB3-UN-CL8-2HS-3	*2:		<input type="checkbox"/>	<input type="checkbox"/>			*2
		CXU10-FAB3-UN-	*2						*2
Modular check valve*	56	CXU10-CHV-UN-00-MA	*2	<input type="checkbox"/>					*2
Distributor*	28	D101-UN-00	*2						*2
Pipe adaptor	21.5	A100-UN-							
L type piping adapter*	28	A101-UN-							
Masking adaptor	10	CXU10-MA-UN-00				<input type="checkbox"/>			
T type bracket set	*1	B110-UN-W		<input type="checkbox"/>					
T type bracket set	*2	B110-H-UN-W							
Fitting set		C1000-J100-UN-W		<input type="checkbox"/>	<input type="checkbox"/>	<input type="checkbox"/>			

1 piping adaptor included. It is not a set of 2pcs. so fill in required fields.

Use this field when using products with different options and port sizes, etc.

Use the T-bracket at a set spacing. Single support joiners can be used for three or fewer stations, and double support joiners can be used for five or fewer stations.

*1: The distance from the pipe center to the mounting surface is 40mm.
*2: The distance from the pipe center to the mounting surface is 45mm.
*3: When using the products at the end of the combination, a piping adaptor (A100-UN, A101-UN) or masking adaptor (CXU30-MA) must be used at the end. (The horizontal direction port does not have threads)

Engineer Comment Field	

Approval	Inspector	Contact

Leave it blank.
CKD approval stamp field.

CXU10 Series custom combination specifications

1000 Series base

Contact _____
Slip no. _____

Quantity _____ sets
Request date _____

Issue _____
Your company name _____
Contact _____
Order no. _____

● Model no.

CXU10 — UN — —

Flow direction	
Blank	Left→Right
X1	Right→Left

For products with an asterisk (*), indicate up/down.

Indicate up/down for the regulator's knob direction, and the port up/down direction for other components.

Indicate the installation position in order from the left as seen from the front.

Part name:	Face to face dimensions	Model no.	Direction	Mounting position						Field for Engineers
				1	2	3	4	5	6	
Filter-regulator	40	W1000- W1100-								
Air filter	40	F1000-								
Oil mist filter	40	M1000-								
High performance oil mist filter	40	MX1000-								
Regulator*	40	R1000-								
	40	R1100-								
Lubricator	40	L1000-								
Pressure switch	28	P1100-UN-		*2						*2
Shut-off valve	40	V1000-								
2 port pilot operated solenoid valve	40	CXU10-EXA-UN-		*2						*2
2 port direct acting solenoid valve	40	CXU10-FAB3-UN-		*2						*2
		CXU10-FAB3-UN-		*2						*2
Modular check valve*	56	CXU10-CHV-UN-00		*2						*2
Distributor*	28	D101-UN-00		*2						*2
Pipe adaptor	21.5	A100-UN-								
L type piping adapter*	28	A101-UN-								
Masking adapter	10	CXU10-MA-UN-00								
T type bracket set	*1	B110-UN-W								
T type bracket set	*2	B110-H-UN-W								
Fitting set		C1000-J100-UN-W								

*1: The distance from the pipe center to the mounting surface is 40mm.

*2: The distance from the pipe center to the mounting surface is 45mm.

*3: When using the products at the end of the combination, a piping adaptor (A100-UN, A101-UN) or masking adapter (CXU30-MA) must be used at the end. (The horizontal direction port does not have threads)

Engineer Comment Field	

Approval	Inspector	Contact

Example of CXU30 Series custom combination specifications

2000, 3000 Series base

General Description

Customized combinations are customer-oriented combinations that meet user needs for diverse combinations. Place orders by filling out the specifications below.
 More solenoid valve types, etc., are available than the conventional customized combinations.

Preparing custom combination specifications

- ① Indicate the full model in the model field for the required model.
 - ② Indicate the installation position of the indicated model with a "○".
 Indicate "UP" or "DOWN" for the orientation.
 - ③ Indicate a "○" in the bracket and joiner fields.
- See individual pages for component ordering and details, etc.

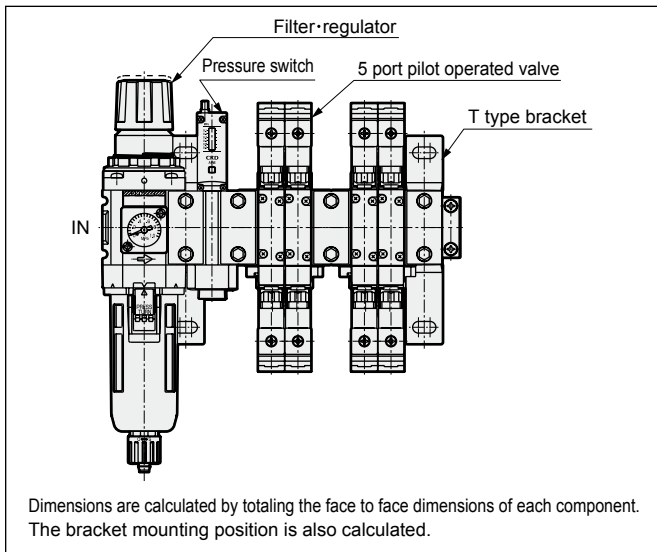

CXU30 Series custom combination specifications

2000, 3000 Series base

Contact _____ Quantity _____ sets
 Slip no. _____ Request date _____

Issue _____
 Your company name _____
 Contact _____
 Order no. _____

● Model no. **CXU30 - UN** - [] - []

Leave it blank. CKD control no.

Flow direction	
Blank	Left→Right
X1	Right→Left

Designate the direction of compressed air flow as seen from the front. Leave blank when no symbol is selected.

For products with an asterisk (*), indicate up/down. Indicate up/down for the regulator's knob direction, and the port up/down direction for other components.

Indicate the installation position in order from the left as seen from the front.

Part name:	Face to face dimensions	Model no.	Direction	Mounting position					Field for Engineers
Filter-regulator	50	W2000-10-W- W2100-		○					
	63	W3000- W3100-							
Air filter	50	F2000-							
	63	F3000-							
Oil mist filter	50	M2000-							
	63	M3000-							
High performance oil mist filter	63	MX3000-							
Regulator*	50	R2000- R2100-							
	63	R3000- R3100-							
	63	L3000-							
Lubricator	80	P4000-							
	31.5	P4100-UN-10-W	*2	○					*2
Shut-off valve	63	V3000-10-W-S V3010-							
2 port direct acting solenoid valve	50	CXU30-FAB4U-UN-8L-							*2
Pilot kick type 2 port solenoid valve	63	CXU30-ADK-UN-00-							*2
2 port pilot operated solenoid valve	63	CXU30-FAD-UN-00-							*2
5 port pilot operated valve	56	CXU30-4G2-UN-33-C8- BS-3			○	○			
		CXU30-4G2-UN-							*2
Distributor	31.5	D401-UN-00-							*2
Distributor	42	D300-							
Pipe adaptor	*3	A400-UN-							
L type piping adapter*	31.5	A401-UN-							
Masking adaptor	21.5	CXU30-MA-UN-00							
T type bracket set	*1	B310-UN-W			○				
Fitting set		C4000-J400-UN-W			○	○			

Use the 5 port pilot operated valve with three or fewer stations.

1 piping adaptor included. It is not a set of 2pcs. so fill in required fields.

Use this field when using products with different options and port sizes, etc.

Use the T-bracket at a set spacing. Single support joiners can be used for three or fewer stations, and double support joiners can be used for five or fewer stations.

*1: The distance from the pipe center to the mounting surface is 45mm.
 *2: When using the products at the end of the combination, a piping adaptor (A400-UN, A401-UN) or masking adaptor (CXU30-MA) must be used at the end. (The horizontal direction port does not have threads)
 *3: Port size 8, 10, 15 are 20mm, 20 is 25mm.

Engineer Comment Field

Approval	Inspector	Contact
Leave it blank. CKD approval stamp field.		

CXU30 Series custom combination specifications

2000, 3000 Series base

Contact _____
Slip no. _____

Quantity _____ sets
Request date _____

Issue _____
Your company name _____
Contact _____
Order no. _____

● Model no.

CXU30 — UN — —

Flow direction	
Blank	Left→Right
X1	Right→Left

For products with an asterisk (*), indicate up/down.

Indicate up/down for the regulator's knob direction, and the port up/down direction for other components.

Indicate the installation position in order from the left as seen from the front.

Part name:	Face to face dimensions	Model no.	Direction	Mounting position						Field for Engineers
Filterregulator	50	W2000- W2100-								
	63	W3000- W3100-								
Air filter	50	F2000-								
	63	F3000-								
Oil mist filter	50	M2000-								
	63	M3000-								
High performance oil mist filter	63	MX3000-								
Regulator*	50	R2000- R2100-								
		R3000- R3100-								
	63									
Lubricator	63	L3000-								
Pressure switch	80	P4000-								
	31.5	P4100-UN-		*2						*2
Shut-off valve	63	V3000- V3010-								
2 port direct acting solenoid valve	50	CXU30-FAB4U-UN-8L-		*2						*2
2 port pilot operated solenoid valve	63	CXU30-FAD-UN-00-		*2						*2
2 port pilot kick solenoid valve	63	CXU30-ADK-UN-00-		*2						*2
5 port pilot operated valve	56	CXU30-4G2-UN- CXU30-4G2-UN-		*2						*2
Distributor*	31.5	D401-UN-00-		*2						*2
Distributor	42	D300-								
Pipe adaptor	*3	A400-UN-								
L type piping adapter*	31.5	A401-UN-								
Masking adapter	21.5	CXU30-MA-UN-00								
T type bracket set	*1	B310-UN-W								
Joiner set		C4000-J400-UN-W								

*1: The distance from the pipe center to the mounting surface is 45mm.

*2: When using the products at the end of the combination, a piping adaptor (A400-UN, A401-UN) or masking adapter (CXU30-MA) must be used at the end. (The horizontal direction port does not have threads)

*3: Port size 8, 10, 15 are 20mm, 20 is 25mm.

Engineer Comment Field	

Approval	Inspector	Contact

Example of CXU30 Series custom combination specifications

4000 Series base

General Description

Customized combinations are customer-oriented combinations that meet user needs for diverse combinations. Place orders by filling out the specifications below.

More solenoid valve types, etc., are available than the conventional customized combinations.

Preparing custom combination specifications

- ① Indicate the full model in the model field for the required model.
- ② Indicate the installation position of the indicated model with a "○".
Indicate "UP" or "DOWN" for the orientation.
- ③ Indicate a "○" in the bracket and joiner fields.
- See individual pages for component ordering and details, etc.

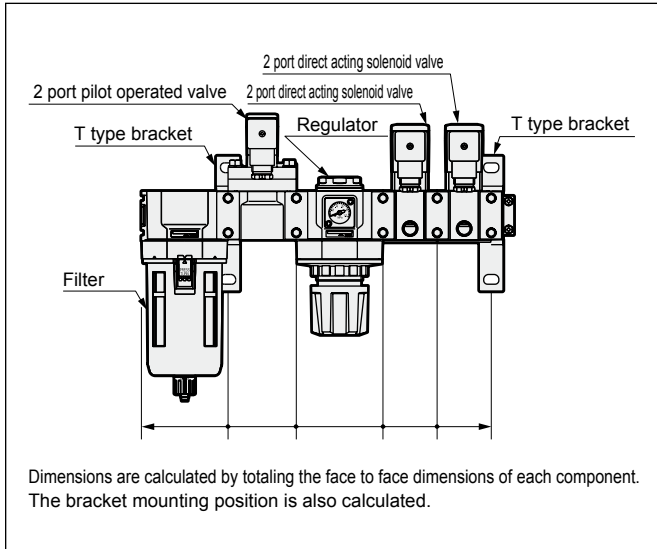

Dimensions are calculated by totaling the face to face dimensions of each component. The bracket mounting position is also calculated.

CXU30 Series custom combination specifications

4000 Series base

Contact _____ Quantity _____ sets
 Slip no. _____ Request date _____
 Issue _____
 Your company name _____
 Contact _____
 Order no. _____

● Model no. **CXU30 - UN -**
 Leave it blank. CKD control no.

Flow direction	
Blank	Left→Right
X1	Right→Left

Designate the direction of compressed air flow as seen from the front. Leave blank when no symbol is selected.

For products with an asterisk (*), indicate up/down. Indicate up/down for the regulator's knob direction, and the port up/down direction for other components. Indicate the installation position in order from the left as seen from the front.

Part name:	Face to face dimensions	Model no.	Direction	Mounting position					Field for Engineers
Filter-regulator	63	W3000- W3100-							
	80	W4000- W4100-							
	63	F3000-							
Air filter	80	F4000-15-W							
	63	M3000-							
Oil mist filter	80	M4000-							
	63	MX3000-							
High performance oil mist filter	80	MX4000-							
	63	R3000- R3100-							
Regulator*	80	R4000-15-W R4100-	Down						
	63	L3000-							
	80	L4000-							
Lubricator	80	P4000-							
	31.5	P4100-UN-							*2
Pressure switch	63	V3000- V3010-							
Shut-off valve	50	CXU30-FAB4U-UN-8L-2HS-3							*2
2 port direct acting solenoid valve	63	CXU30-ADK-UN-00-2HS-3							*2
2 port pilot operated solenoid valve	63	CXU30-FAD-UN-00-							*2
5 port pilot operated valve	56	CXU30-4G2-UN-							
		CXU30-4G2-UN-							*2
Distributor	31.5	D401-UN-00-							*2
Distributor	42	D300-							
Pipe adaptor	*3	A400-UN-							
L type piping adapter*	31.5	A401-UN-							
Masking adapter	21.5	CXU30-MA-UN-00							
T type bracket set	**1	B410-UN-W							
Fitting set		C4000-J400-UN-W							

Use the 5 port pilot operated valve with three or fewer stations.

1 piping adaptor included. It is not a set of 2pcs. so fill in required fields..

Use this field when using products with different options and port sizes, etc.

*1: The distance from the pipe center to the mounting surface is 55 mm.
 *2: When using the products at the end of the combination, a piping adaptor (A400-UN, A401-UN) or masking adapter (CXU30-MA) must be used at the end. (The horizontal direction port does not have threads)
 *3: Port size 8, 10, 15 are 20mm, 20 is 25mm.

Engineer Comment Field

Approval	Inspector	Contact

Use the T-bracket at a set spacing. Single support joiners can be used for three or fewer stations, and double support joiners can be used for five or fewer stations.

Leave it blank. CKD approval stamp field.

CXU30 Series custom combination specifications

4000 Series base

Contact _____
Slip no. _____

Quantity _____ sets
Request date _____

Issue _____
Your company name _____
Contact _____
Order no. _____

● Model no.
CXU30 — UN — —

Flow direction	
Blank	Left→Right
X1	Right→Left

For products with an asterisk (*), indicate up/down.
Indicate up/down for the regulator's knob direction, and the port up/down direction for other components.

Indicate the installation position in order from the left as seen from the front.

Part name:	Face to face dimensions	Model no.	Direction	Mounting position						Field for Engineers
Filter-regulator	63	W3000- W3100-								
	80	W4000- W4100-								
Air filter	63	F3000-								
	80	F4000-								
Oil mist filter	63	M3000-								
	80	M4000-								
High performance oil mist filter	63	MX3000-								
	80	MX4000-								
Regulator*	63	R3000- R3100-								
		R4000- R4100-								
	80									
Lubricator	63	L3000-								
	80	L4000-								
Pressure switch	80	P4000-								
	31.5	P4100-UN-		*2						*2
Shut-off valve	63	V3000- V3010-								
2 port direct acting solenoid valve	50	CXU30-FAB4U-UN-8L-		*2						*2
2 port pilot kick solenoid valve	63	CXU30-ADK-UN-00-		*2						*2
2 port pilot operated solenoid valve	63	CXU30-FAD-UN-00-		*2						*2
5 port pilot operated valve	56	CXU30-4G2-UN- CXU30-4G2-UN-		*2						*2
Distributor*	31.5	D401-UN-00-		*2						*2
Distributor	42	D300-								
Pipe adaptor	*3	A400-UN-								
L type piping adapter*	31.5	A401-UN-								
Masking adapter	21.5	CXU30-MA-UN-00								
T type bracket set	*1	B410-UN-W								
Fitting set		C4000-J400-UN-W								

*1: The distance from the pipe center to the mounting surface is 55 mm.
*2: When using the products at the end of the combination, a piping adapter (A400-UN, A401-UN) or masking adapter (CXU30-MA) must be used at the end. (The horizontal direction port does not have threads)
*3: Port size 8, 10, 15 are 20mm, 20 is 25mm.

Engineer Comment Field	

Approval	Inspector	Contact

Example of CXU13 Series custom combination specifications

1000, 2000, 3000 Series mix

General Description

Customized combinations are customer-oriented combinations that meet user needs for diverse combinations. Place orders by filling out the specifications below.

More solenoid valve types, etc., are available than the conventional customized combinations.

Preparing custom combination specifications

- ① Indicate the full model in the model field for the required model.
- ② Indicate the installation position of the indicated model with a "○". Indicate "UP" or "DOWN" for the orientation.
- ③ Indicate a "○" in the bracket and joiner fields.
- See individual pages for component ordering and details, etc.

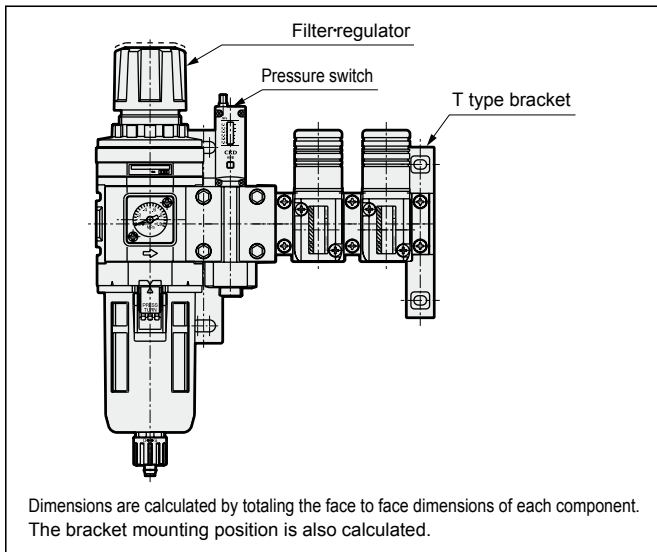

CXU13 Series custom combination specifications

1000, 3000 Series mix

Contact _____ Quantity _____ sets
 Slip no. _____ Request date _____
 Issue _____
 Your company name _____
 Contact _____
 Order no. _____

● Model no. **CXU13 - UN -**
 Leave it blank.
 CKD control no.

Flow direction
 Blank Left→Right
 X1 Right→Left
 Designate the direction of compressed air flow as seen from the front.
 Leave blank when no symbol is selected.

For products with an asterisk (*), indicate up/down.
 Indicate up/down for the regulator's knob direction, and the port up/down direction for other components.
 Indicate the installation position in order from the left as seen from the front.

4000 Series not available since the height of B410-W and B110-H-W is different.

Use the 5 port pilot operated valve with three or fewer stations.

1 piping adaptor included. It is not a set of 2pcs. so fill in required fields.

Part name	Face to face dimensions	Model no.	Direction	Mounting position	Field for Engineers
Filterregulator	40-1000 50-2000 63-3000	W3000-10-W W 100-		<input type="radio"/>	
Air filter	40-1000 50-2000 63-3000	F 000-			
Oil mist filter	40-1000 50-2000 63-3000	M 000-			
High performance oil mist filter	40	MX1000-			
	63	MX3000-			
Regulator	40-1000 50-2000 63-3000	R 000- R 100-			
	40	L1000-			
Lubricator	63	L3000-			
	80	P4000-			
	28	P1100-UN-	*2		*2
Pressure switch	31.5	P4100-UN-	*2	<input type="radio"/>	*2
	40	V1000-			
Shut-off valve	63	V30 0-			
	40	CXU10-EXA-UN-	*2		*2
2 port direct acting solenoid valve	40	CXU10-FAB3-UN-	*2	<input type="radio"/>	*2
2 port direct acting solenoid valve	50	CXU30-FAB4U-UN-8L-	*2		*2
Pilot kick type 2 port solenoid valve	63	CXU30-FAD-UN-00-	*2		*2
		CXU30-FAD-UN-00-	*2		*2
5 port pilot operated valve	56	CXU30-4G2-UN-	*2		*2
		CXU30-4G2-UN-	*2		*2
Modular check valve*	56	CXU10-CHV-UN-00-	*2		*2
Module transform adaptor	16	CXU13-CA-00	*2	<input type="radio"/>	*2
	28	D101-UN-00-			
Distributor	31.5	D401-UN-00-	*2		*2
	42	D300-			
Pipe adaptor	21.5	A100-UN-			
	*3	A400-UN-			
L type piping adaptor*	28	A101-UN-			
	31.5	A401-UN-			
Masking adaptor	10	CXU10-MA-UN-00		<input type="radio"/>	
	21.5	CXU30-MA-UN-00			
T type bracket set	*1	B110-H-UN-W		<input type="radio"/>	
T type bracket set	*1	B310-UN-W		<input type="radio"/>	
Fitting set		C1000-J100-UN-W		<input type="radio"/>	
Fitting set		C4000-J400-UN-W		<input type="radio"/>	

Use the T-type bracket in regular intervals. Single support joiners can be used for three or fewer stations.

*1: The distance from the pipe center to the mounting surface is 45mm.
 *2: When using the products at the end of the combination, a piping adaptor (A*00-UN, A*01-UN) or masking adaptor (CXU*0-MA) must be used at the end. (The horizontal direction port does not have threads)
 *3: Port size 8, 10, 15 are 20mm, 20 is 25mm.

Engineer Comment Field

Approval _____ Inspector _____ Contact _____
 Leave it blank.
 CKD approval stamp field.

CXU13 Series custom combination specifications

1000, 2000, 3000 Series mix

Contact _____
Slip no. _____

Quantity _____ sets
Request date _____

Issue _____
Your company name _____
Contact _____
Order no. _____

● Model no.

CXU13 — UN — —

Flow direction	
Blank	Left→Right
X1	Right→Left

For products with an asterisk (*), indicate up/down. Indicate up/down for the regulator's knob direction, and the port up/down direction for other components.

Indicate the installation position in order from the left as seen from the front.

Part name:	Face to face dimensions	Model no.	Direction	Mounting position						Field for Engineers
Filterregulator	40:1000	W 000-								
	50:2000	W 100-								
Air filter	40:1000	F 000-								
	50:2000									
	63:3000									
Oil mist filter	40:1000	M 000-								
	50:2000									
	63:3000									
High performance oil mist filter	40	MX1000-								
	63	MX3000-								
Regulator	40:1000	R 000-								
	50:2000	R 100-								
	63:3000									
Lubricator	40	L1000-								
	63	L3000-								
	80	P4000-								
Pressure switch	28	P1100-UN-								
	31.5	P4100-UN-								*2
	40	V1000-								
Shut-off valve	63	V3000-								
	40	CXU10-EXA-UN-								*2
2 port pilot operated solenoid valve	40	CXU10-FAB3-UN-								*2
2 port direct acting solenoid valve	50	CXU30-FAB4U-UN-8L-								*2
2 port pilot kick solenoid valve	63	CXU30-ADK-UN-00-								*2
2 port pilot operated solenoid valve	63	CXU30-FAD-UN-00-								*2
5 port pilot operated valve	56	CXU30-4G2-UN-								*2
		CXU30-4G2-UN-								*2
Modular check valve*	56	CXU10-CHV-UN-00								*2
Module transform adaptor	16	CXU13-CA-00								*2
Distributor*	28	D101-UN-00-								*2
	31.5	D401-UN-00-								*2
Distributor	42	D300-								
Pipe adaptor	21.5	A100-UN-								
	*3	A400-UN-								
L type piping adapter*	28	A101-UN-								
	31.5	A401-UN-								
Masking adapter	10	CXU10-MA-UN-00								
	21.5	CXU30-MA-UN-00								
T type bracket set	*1	B110-H-UN-W								
T type bracket set	*1	B310-UN-W								
Joiner set		C1000-J100-UN-W								
Joiner set		C4000-J400-UN-W								

*1: The distance from the pipe center to the mounting surface is 45mm.

*2: When using the products at the end of the combination, a piping adaptor (A*00-UN, A*01-UN) or masking adaptor (CXU*0-MA) must be used at the end. (The horizontal direction port does not have threads)

*3: Port size 8, 10, 15 are 20mm, 20 is 25mm.

Engineer Comment Field	

Approval	Inspector	Contact

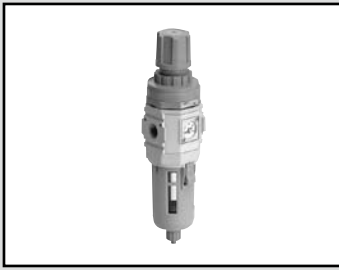

Filter-regulator Standard white series

W1000·W2000·W3000·W4000-W Series

Introducing the 5µm dust removing element and 0.3µm tar removing element

Port size: Rc1/8 to Rc1/2

JIS symbol



W1000	W2000
Face to face 40mm	Face to face 50mm
W3000	W4000
Face to face 63mm	Face to face 80mm

How to order

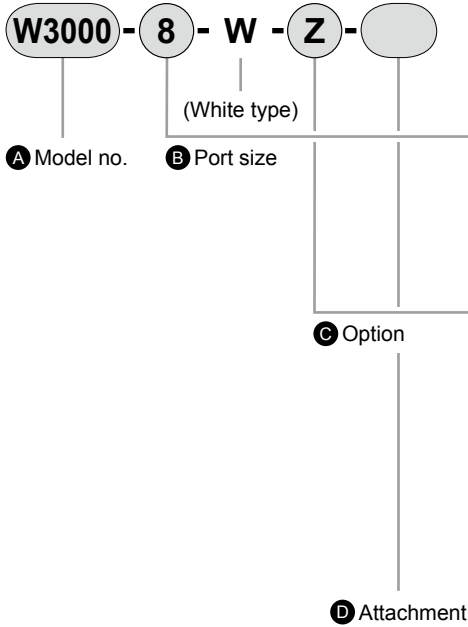

A Model no.			
W	W	W	W
1	2	3	4
0	0	0	0
0	0	0	0

Symbol	Descriptions	W1000	W2000	W3000	W4000
B Port size					
6	Rc1/8	●			
8	Rc1/4	●	●	●	●
10	Rc3/8		●	●	●
15	Rc1/2				●

C Option		Note 2	W1000	W2000	W3000	W4000
Drainage Note 3	Blank	With manual drain cock	●	●	●	●
	F	Automatic drain with manual override (NO type: exhausts without pressurization)			●	●
	F1	Automatic drain with manual override (NC type: no exhaust without pressurization)	●	●	●	●
Bowl material	Blank	Polycarbonate bowl	●	●	●	●
	Z	Nylon bowl	●	●	●	●
	M	Metal bowl			●	●
	M1	With metal bowl, manual drain cock Note 4		●	●	●
Element	Blank	5µm	●	●	●	●
	Y	0.3µm (submicron) Note 5			●	●
Pressure range	Blank	0.05 to 0.85MPa	●	●	●	●
	L	0.05 to 0.35MPa		●	●	●
Relief	Blank	With relief mechanism	●	●	●	●
	N	Non-relief type	●	●	●	●
Pressure gauge	Blank	With standard pressure gauge (G401)	●	●	●	●
	T	Without pressure gauge (gauge port assembled sealed)	●	●	●	●
	T8	Port for mounting pressure gauge assembled open	●	●	●	●
	T6 ^{Note 6}	Compatibility with digital pressure sensor PPX	●	●	●	●
	R1 ^{Note 1}	Pressure switch with display PPD assembly	●		●	●
Flow direction	Blank	Standard flow (left to right)	●	●	●	●
	X1	Reverse flow (right to left)	●	●	●	●

D Attachment		W1000	W2000	W3000	W4000
Blank	Not included	●	●	●	●
G49P	G49D-8-P10 (L: G49D-8-P04)	●	●	●	●
G59P	G59D-8-P10 (L: G59D-8-P04)	●		●	●
G40P	G40D-8-P10 (L: G40D-8-P04)	●	●	●	●
G50P	G50D-8-P10 (L: G50D-8-P04)	●		●	●
G41P	G41D-8-P10 (L: G41D-8-P04)	●	●	●	●
G52P	G52D-8-P10 (L: G52D-8-P10)	●	●	●	●
R2 ^{Note 6}	Digital pressure sensor: PPX-R10N-6M	●	●	●	●

⚠ Cautions for model No. selection

- Note 1: The pressure switch with R1 indicator is black.
- Note 2: Select options for drainage, bowl material, element, and regulator sections. When selecting options for several items, list options in order from the top.
- Note 3: Refer to "Pneumatic, Vacuum and Auxiliary Components (catalog No. CB-024SA)" for working conditions of the automatic drain.
- Note 4: A manual drain cock is provided on all drain discharges
- Note 5: Refer to "Pneumatic, Vacuum and Auxiliary Components (No.CV-024SA)" for max flow rate for option "Y".
- Note 6: When option "T6" is selected, only "Blank" or "R2" can be selected for the Ⓧ attachment (included). The digital pressure sensor PPX mounting port (Rc1/8) is assembled open.

Refer to "Modular type F.R.L. (No. CC-962)" and "Modular type F.R.L. 2000 Series (No. CC-982)" for details on specifications and internal structure.

Dimensions

● W1000

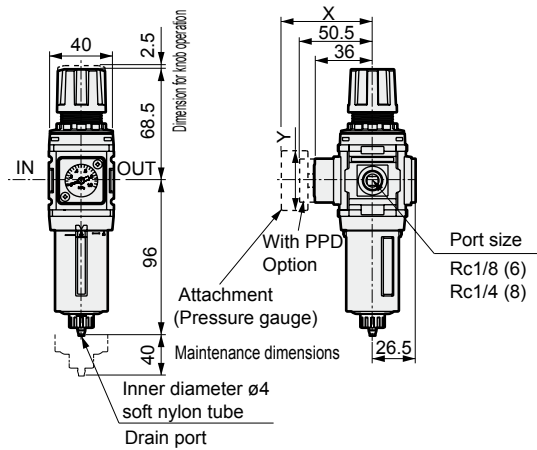

● W2000

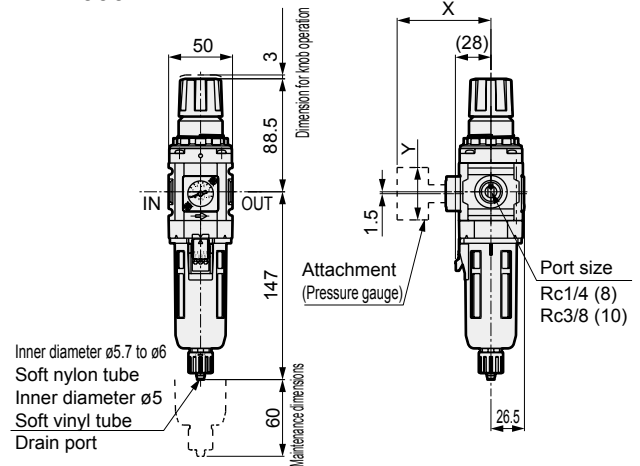

● W3000

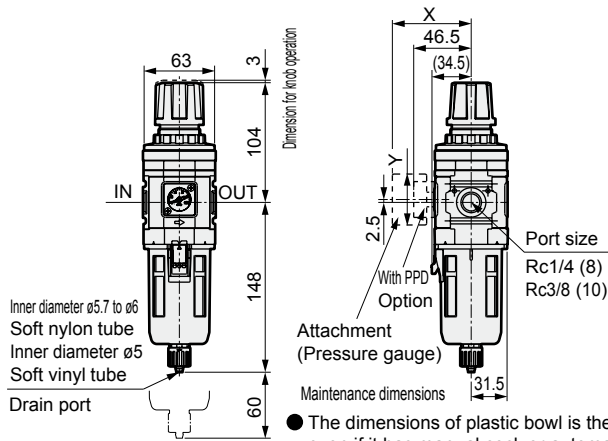

● W4000

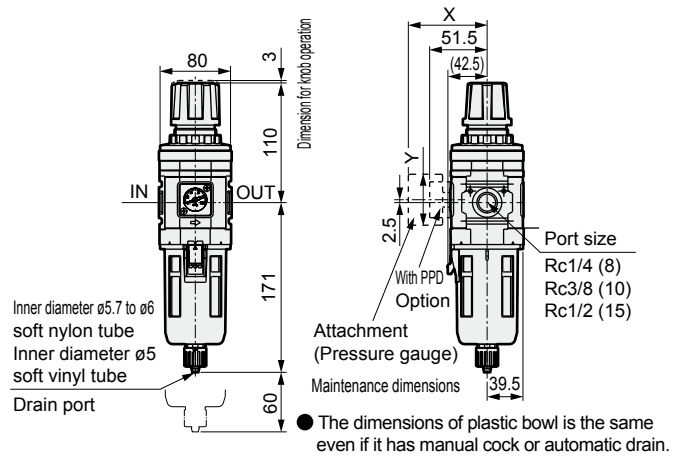

● The dimensions of plastic bowl is the same even if it has manual cock or automatic drain.

● The dimensions of plastic bowl is the same even if it has manual cock or automatic drain.

Option dimensions with pressure gauge included

Attached pressure gauge	X				Y			
	W1000	W2000	W3000	W4000	W1000	W2000	W3000	W4000
G49P	(73.5)	(73)	(69.5)	(74.5)	ø43.5	ø43.5		ø43.5
G59P	(76)	-	(72)	(77)	ø52	-		ø52
G40P	(75.5)	(75)	(71.5)	(76.5)	ø42.5	ø42.5		ø42.5
G50P	(75.5)	-	(71.5)	(76.5)	ø52.5	-		ø52.5
G41P	(74)	(73.5)	(70)	(75)	ø42	ø42		ø42
G52P	(86)	(85.5)	(82)	(86)	ø52.5	ø52.5		ø52.5
R2	(74)	(73)	(69.5)	(75)	□ 30	□ 30		□ 30

Option dimensions

● Metal bowl (option)

with automatic drain (FM, F1M)

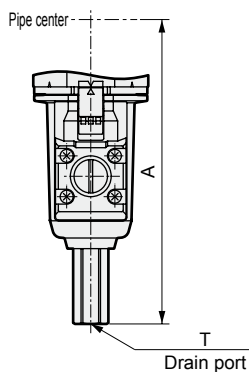

Automatic drain cock (M)

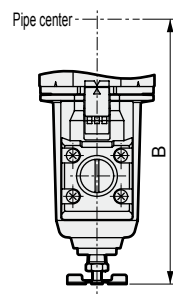

Standard manual drain cock (M1)

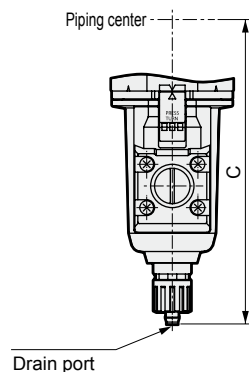

Dimensions table

Model no.	F1M	M	M1
	A	B	C
W2000	-	-	147
W3000	163.5	143.5	154
W4000	187	166.5	177

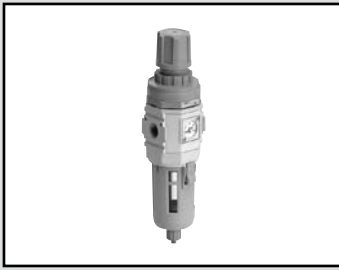

Reverse filter-regulator Standard white series

W1100·W2100·W3100·W4100-W Series

Introducing the 5µm dust removing element and 0.3µm tar removing element, with back flow function, to the lineup. Ionizer purge gas flow control Port size: Rc1/8 to Rc1/2

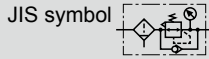

W1100	W2100
Face to face 40mm	Face to face 50mm
W3100	W4100
Face to face 63mm	Face to face 80mm

How to order

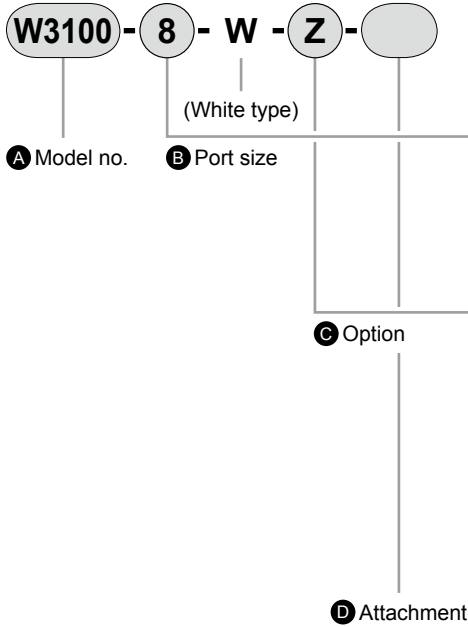

A Model no.			
W1100	W2100	W3100	W4100
1	1	1	1
0	0	0	0
0	0	0	0

Symbol	Descriptions	W1100	W2100	W3100	W4100
B Port size					
6	Rc1/8	●			
8	Rc1/4	●	●	●	●
10	Rc3/8		●	●	●
15	Rc1/2				●

C Option		Note 2, Note 3				
Drainage Note 4	Blank	With manual drain cock	●	●	●	●
	F	Automatic drain with manual override (NO type: exhausts without pressurization)			●	●
	F1	Automatic drain with manual override (NC type: no exhaust without pressurization)	●	●	●	●
Bowl material	Blank	Polycarbonate bowl	●		●	●
	Z	Nylon bowl	●	●	●	●
	M	Metal bowl			●	●
	M1	With metal bowl, manual drain cock Note 5		●	●	●
Element	Blank	5µm	●	●	●	●
	Y	0.3µm(submicron) Note 6			●	●
Pressure range	Blank	0.05 to 0.85MPa	●	●	●	●
	L	0.05 to 0.35MPa	●	●	●	●
Relief	Blank	With relief mechanism	●	●	●	●
	N	Non-relief type	●	●	●	●
Pressure gauge	Blank	With standard pressure gauge (G401)	●	●	●	●
	T	Without pressure gauge (gauge port assembled sealed)	●	●	●	●
	T8	Port for mounting pressure gauge assembled open	●	●	●	●
	T6 ^{Note 7}	Compatibility with digital pressure sensor PPX	●	●	●	●
	R1 ^{Note 1}	Pressure switch with display PPD assembly	●		●	●
Flow direction	Blank	Standard flow (left to right)	●	●	●	●
	X1	Reverse flow (right to left)	●	●	●	●

D Attachment		W1100	W2100	W3100	W4100
Blank	Not included	●	●	●	●
G49P	G49D-8-P10 (L: G49D-8-P04)	●	●	●	●
G59P	G59D-8-P10 (L: G59D-8-P04)	●		●	●
G40P	G40D-8-P10 (L: G40D-8-P04)	●	●	●	●
G50P	G50D-8-P10 (L: G50D-8-P04)	●		●	●
G41P	G41D-8-P10 (L: G41D-8-P04)	●	●	●	●
G52P	G52D-8-P10 (L: G52D-8-P10)	●	●	●	●
R2 ^{Note 7}	Digital pressure sensor: PPX-R10N-6M	●	●	●	●

⚠ Cautions for model No. selection

- Note 1: The pressure switch with R1 indicator is black.
- Note 2: Select options for drainage, bowl material, element, and regulator sections.
When selecting options for several items, list options in order from the top.
- Note 3: Position of the check valve and pressure gauge can not be changed.
If the reverse direction of IN and OUT are required, indicate "X1" in the end of optional section.
- Note 4: Refer to "Pneumatic, Vacuum and Auxiliary Components (catalog No. CB-024SA)" for working conditions of the automatic drain.
- Note 5: All drainage type will have an manual drain cock.
- Note 6: Refer to "Pneumatic, Vacuum and Auxiliary Components (No.CV-024SA)" for max flow rate for option "Y".
- Note 7: When option "T6" is selected, only "Blank" or "R2" can be selected for the pressure gauge (included).
The digital pressure sensor PPX mounting port (Rc1/8) is assembled open.

Refer to "Modular type F.R.L. (No. CC-962)" and "Modular type F.R.L. 2000 Series (No. CC-982)" for details on specifications and internal structure.

Dimensions

● W1100

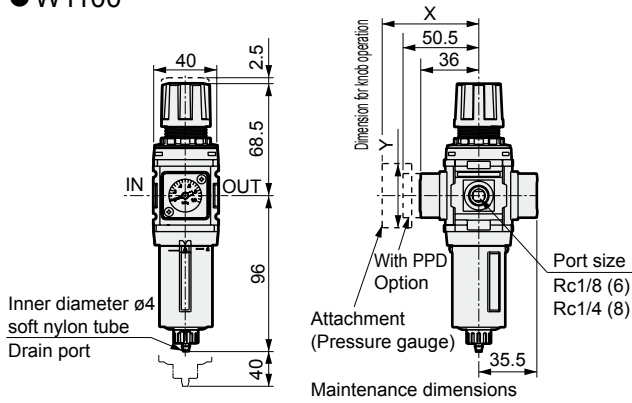

● W2100

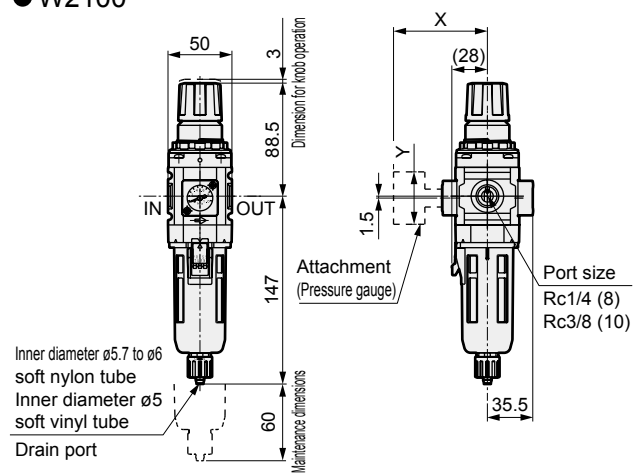

● W3100

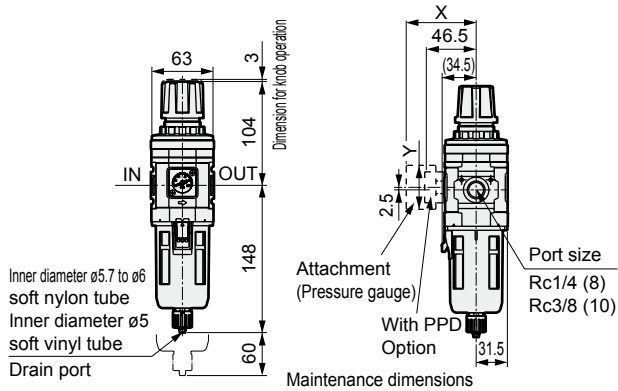

● W4100

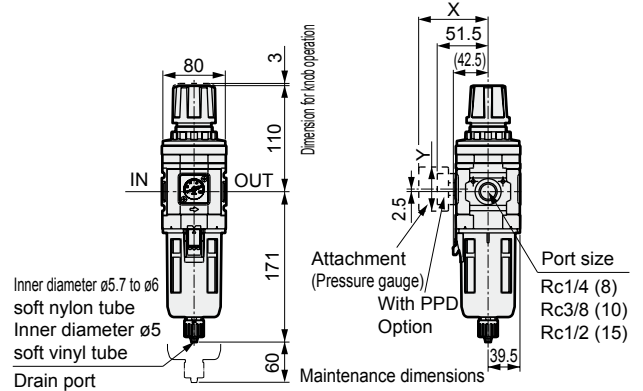

● Regarding the plastic bowl, the same dimensions apply for the type with manual cock or automatic drain.

● Regarding the plastic bowl, the same dimensions apply for the type with manual cock or automatic drain.

Option dimensions with pressure gauge included

Attached pressure gauge	X				Y			
	W1000	W2000	W3000	W4000	W1000	W2000	W3000	W4000
G49P	(73.5)	(73)	(69.5)	(74.5)	ø43.5	ø43.5		ø43.5
G59P	(76)	-	(72)	(77)	ø52	-		ø52
G40P	(75.5)	(75)	(71.5)	(76.5)	ø42.5	ø42.5		ø42.5
G50P	(75.5)	-	(71.5)	(76.5)	ø52.5	-		ø52.5
G41P	(74)	(73.5)	(70)	(75)	ø42	ø42		ø42
G52P	(86)	(85.5)	(82)	(86)	ø52.5	ø52.5		ø52.5
R2	(74)	(73)	(69.5)	(75)	□ 30	□ 30		□ 30

Option dimensions

● Metal bowl (option)

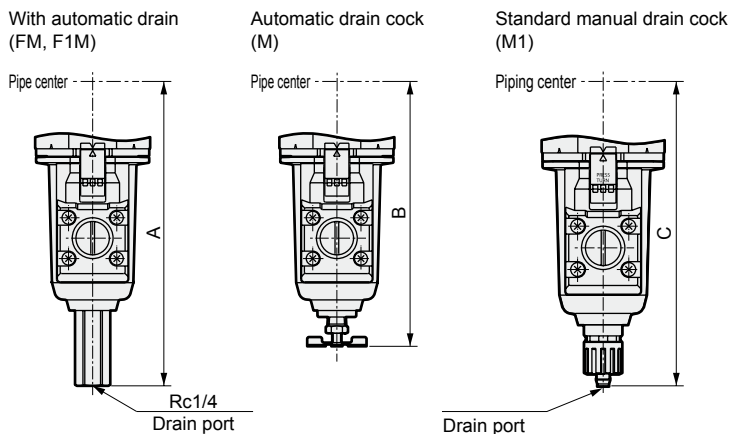

Dimensions table

Model no.	F1M	M	M1
	A	B	C
W2100	-	-	147
W3100	163.5	143.5	154
W4000	187	166.5	177

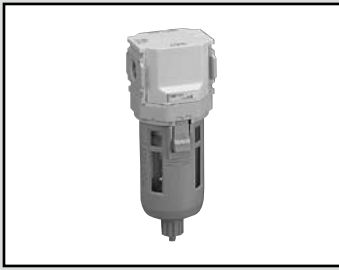

Air filter Standard white series

F1000·F2000·F3000·F4000-W Series

Introducing the 5μm element for dust removal and 0.3μm element for tar removal
Port size: 1/8 to 1/2

JIS symbol



F1000	F2000
Face to face 40mm	Face to face 50mm
F3000	F4000
Face to face 63mm	Face to face 80mm

How to order

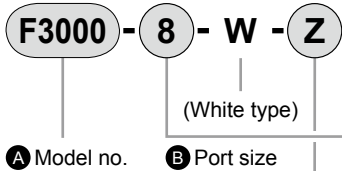

A Model no.			
F	F	F	F
1	2	3	4
0	0	0	0
0	0	0	0

Symbol	Descriptions				
B Port size					
6	Rc1/8	●			
8	Rc1/4	●	●	●	●
10	Rc3/8		●	●	●
15	Rc1/2				●

C Option		Note 1				
Drainage	Blank	With manual drain cock	●	●	●	●
	F	Automatic drain with manual override (NO type: exhausts without pressurization)			●	●
	F1	Automatic drain with manual override (NC type: no exhaust without pressurization)	●	●	●	●
Bowl material	Blank	Polycarbonate bowl	●	●	●	●
	Z	Nylon bowl	●	●	●	●
	M	Metal bowl			●	●
	M1	With metal bowl, manual drain cock Note 3		●	●	●
Element	Blank	5μm	●	●	●	●
	Y	0.3μm (submicron)			●	●
Flow direction	Blank	Standard flow (left to right)	●	●	●	●
	X1	Reverse flow (right to left)	●	●	●	●

⚠ Cautions for model No. selection

- Note 1: Select options for drainage, bowl material and element and flow direction.
When selecting options for several items, list options in order from the top.
- Note 2: Refer to "Pneumatic, Vacuum and Auxiliary Components (catalog No. CB-024SA)" for working conditions of the automatic drain.
- Note 3: All drainage type will have an manual drain cock.

Dimensions

● F1000

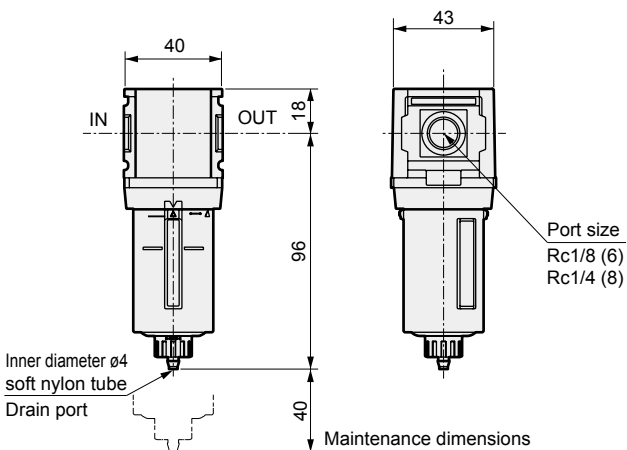

● F2000

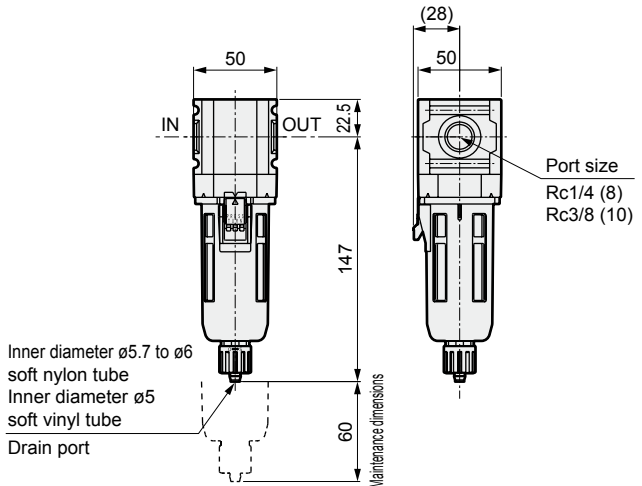

• Option dimensions
With automatic drain (F1)

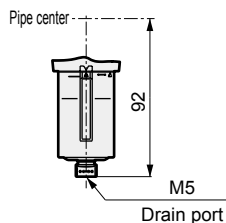

Dimensions

● F3000

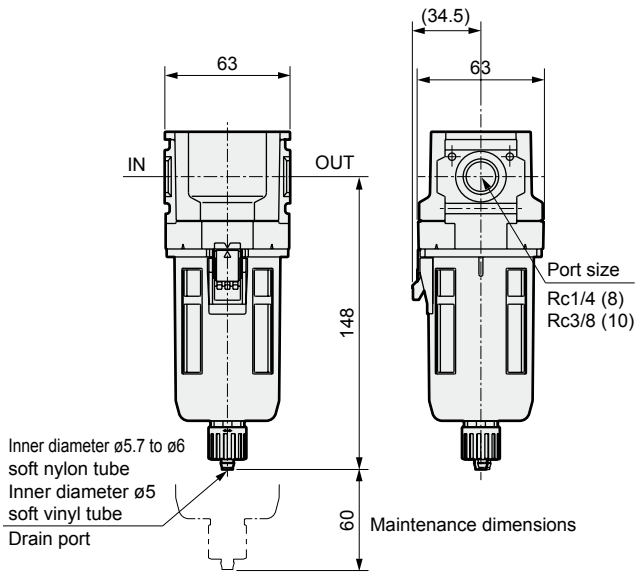

● Regarding the plastic bowl, the same dimensions apply for the type with manual cock or automatic drain.

● F4000

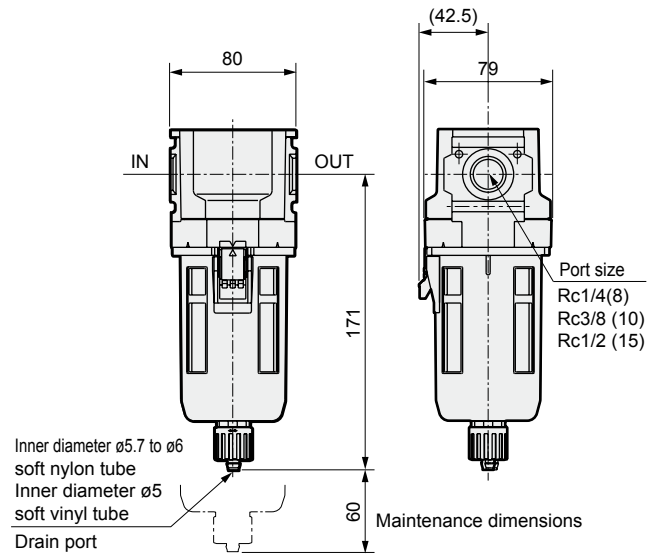

● Regarding the plastic bowl, the same dimensions apply for the type with manual cock or automatic drain.

● Metal bowl (option)

Metal manual cock
With automatic drain (F1M)

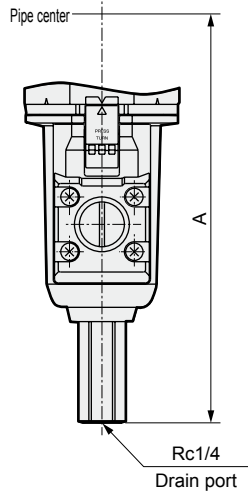

With petcock (M)

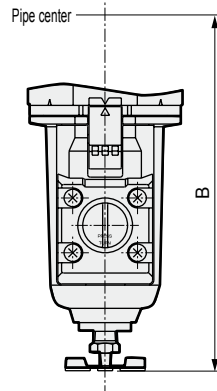

Standard manual drain cock (M1)

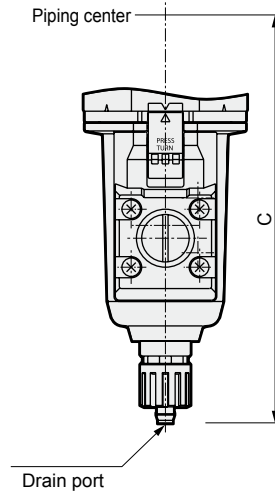

Dimensions table

Model no.	F1M	M	M1
	A	B	C
F2000	-	-	147
F3000	164	143.5	154
F4000	187	166.5	177

Refer to "Modular type F.R.L. (No. CC-962)" and "Modular type F.R.L. 2000 Series (No. CC-982)" for details on specifications and internal structure.



Oil mist filter Standard white Series

M1000 · M2000 · M3000 · M4000-W Series

Ideal for circuits susceptible to oil, including measuring, and instrumentation circuits

Port size: 1/8 to 1/2

JIS symbol



M1000	M2000
Face to face 40mm	Face to face 50mm
M3000	M4000
Face to face 63mm	Face to face 80mm

How to order

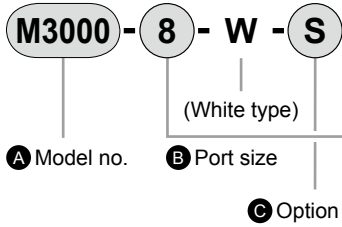

A Model no.			
M	M	M	M
1	2	3	4
0	0	0	0
0	0	0	0
0	0	0	0

Symbol	Descriptions				
B Port size					
6	Rc1/8	●			
8	Rc1/4	●	●	●	●
10	Rc3/8		●	●	●
15	Rc1/2				●

⚠ Cautions for model No. selection

- Note 1: Select the option for drainage, bowl material and mantle and flow direction.
When selecting options for several items, list options in order from the top.
- Note 2: N.O. automatic drain cannot be selected.
- Note 3: Refer to "Pneumatic, Vacuum and Auxiliary Components (catalog No. CB-024SA)" for working conditions of the automatic drain.
- Note 4: All drainage type will have an manual drain cock.
- Note 5: Combination with option F1 is not possible.
- Note 6: Not selectable with "M" and "X". Replace the element before the differential pressure indicator becomes red.
The differential pressure indicator functions only when compressed air is flowing. Please be warned that only pressurizing it will not operate it.

C Option		Note 1				
Drain Discharge Note 2, Note 3	Blank	With manual drain cock	●	●	●	●
	F1	Automatic drain with manual override (NC type: no exhaust without pressurization)	●	●	●	●
Bowl material	Blank	Polycarbonate bowl	●	●	●	●
	Z	Nylon bowl	●	●	●	●
	M	Metal bowl			●	●
	M1	With metal bowl, manual drain cock Note 4		●	●	●
Mantle (element)	Blank	M type (nominal 0.01 m; remaining oil 0.01 mg/m ³ or less)	●	●	●	●
	S	S type (0.3 m; remaining oil 0.5 mg/m ³ or less)	●	●	●	●
	X Note 5	X type (deodorization; remaining oil 0.03 mg/m ³)	●	●	●	●
Differential pressure indicator	Q1 Note 6	With differential pressure indicator				●
Flow direction	Blank	Standard flow (left to right)	●	●	●	●
	X1	Reverse flow (right to left)	●	●	●	●

Dimensions

● M1000

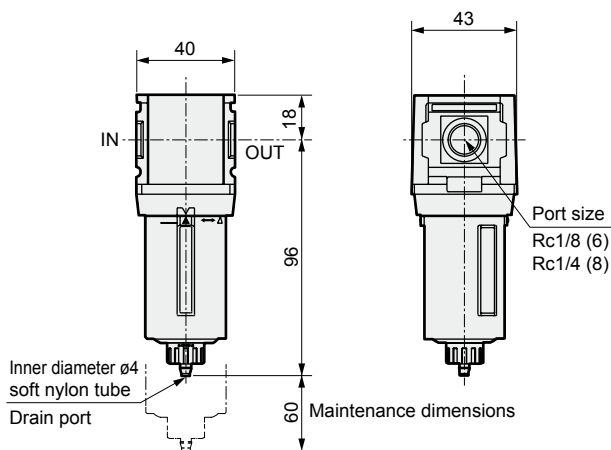

● M2000

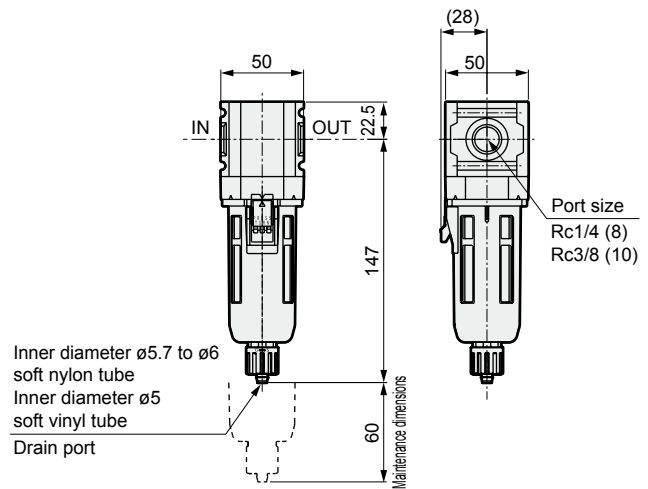

• Option dimensions
With automatic drain (F1)

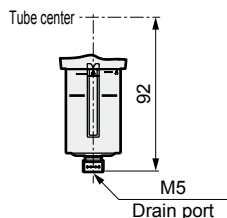

Dimensions

● M3000

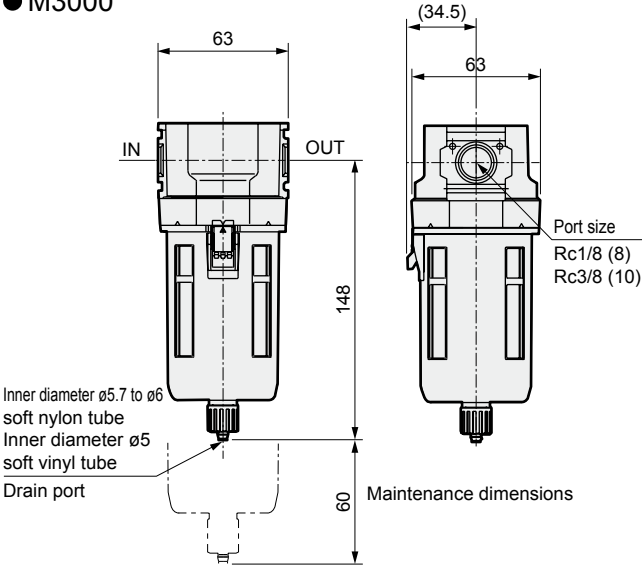

● Regarding the plastic bowl, the same dimensions apply for the type with manual cock or automatic drain.

● M4000

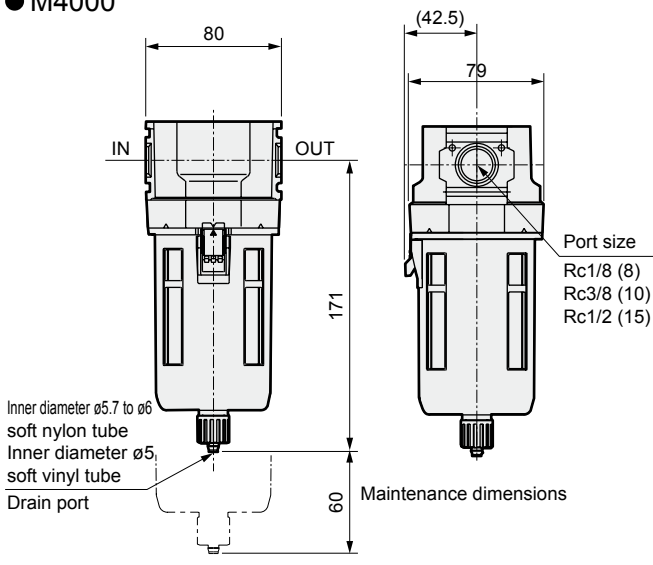

● Regarding the plastic bowl, the same dimensions apply for the type with manual cock or automatic drain.

● With differential pressure indicator (option) Q1

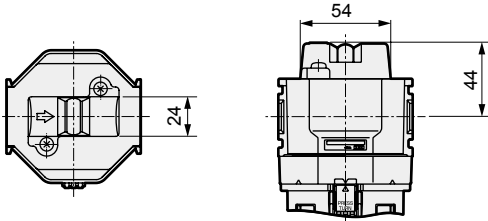

● Metal bowl (option)

Metal manual cock
With automatic drain (F1M)

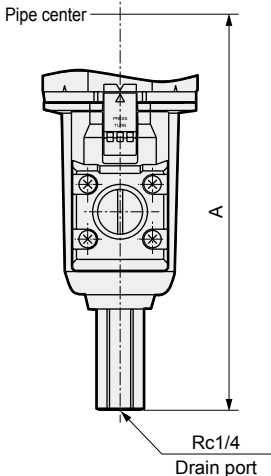

With petcock (M)

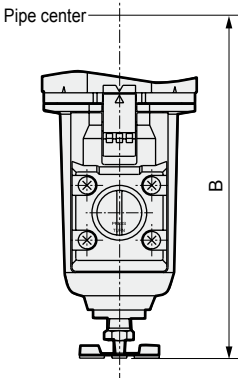

Standard manual drain cock (M1)

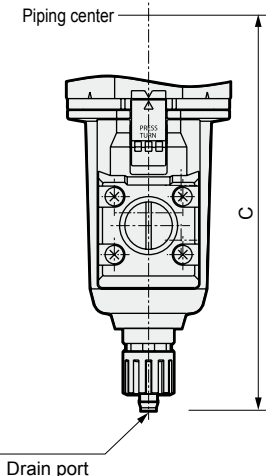

Dimensions table

Model no.	F1M	M	M1
	A	B	C
M2000	-	-	147
M3000	164	143.5	154
M4000	187	166.5	177

Refer to "Modular type F.R.L. (No. CC-962)" and "Modular type F.R.L. 2000 Series (No. CC-982)" for details on specifications and internal structure.

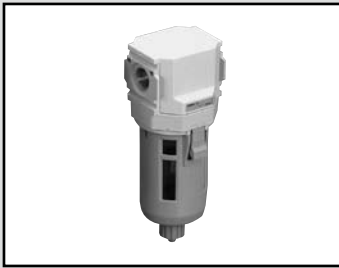

High performance oil mist filter Standard white Series MX1000·MX3000·MX4000-W Series

Secondary side oil concentration 0.001 mg/m³
Suitable for optical equipment such as optical positioning units and laser processing machines
Port size: 1/8 to 1/2

JIS symbol



MX1000

Face to face
40mm

MX3000

Face to face
63mm

MX4000

Face to face
80mm

How to order

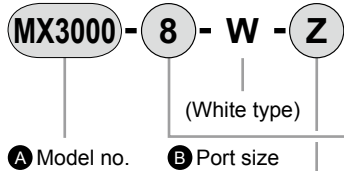

A Model no.		
M	M	M
X	X	X
1	3	4
0	0	0
0	0	0
0	0	0

Symbol	Descriptions			
B Port size				
6	Rc1/8	●		
8	Rc1/4	●	●	●
10	Rc3/8		●	●
15	Rc1/2			●

C Option		Note 1			
Drain Discharge Note 2, Note 3	Blank	With manual drain cock	●	●	●
	F1	Automatic drain with manual override (NC type: no exhaust without pressurization)	●	●	●
Bowl material	Blank	Polycarbonate bowl	●	●	●
	Z	Nylon bowl	●	●	●
	M	Metal bowl		●	●
Flow direction	M1	With metal bowl, manual drain cock Note 4		●	●
	Blank	Standard flow (left to right)	●	●	●
	X1	Reverse flow (right to left)	●	●	●

⚠ Cautions for model No. selection

Note 1: Select options for drainage discharge, bowl material and differential pressure direction.

When selecting options for several items, list options in order from the top.

Note 2: N.O. automatic drain cannot be selected.

Note 3: Refer to "Pneumatic, Vacuum and Auxiliary Components (catalog No. CB-024SA)" for working conditions of the automatic drain.

Note 4: All drainage type will have an manual drain cock.

Dimensions

● MX1000

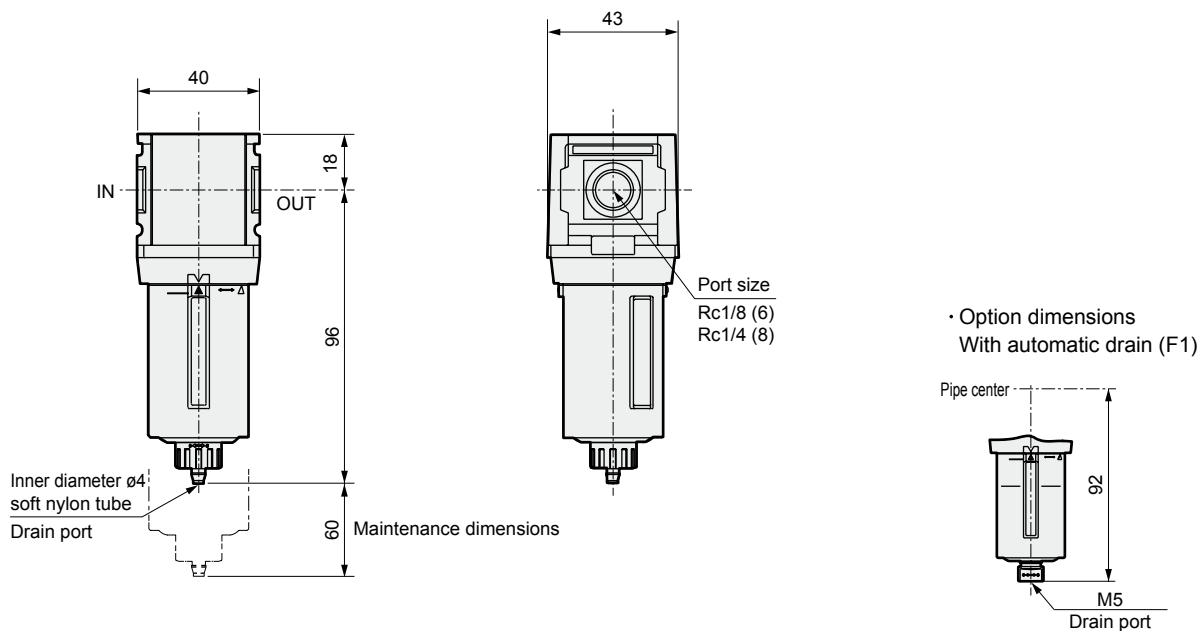

Dimensions

● MX3000

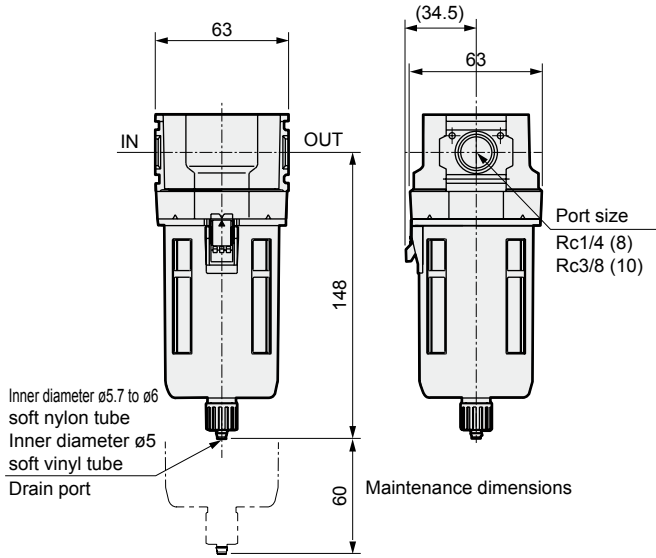

● Regarding the plastic bowl, the same dimensions apply for the type with manual cock or automatic drain.

● MX4000

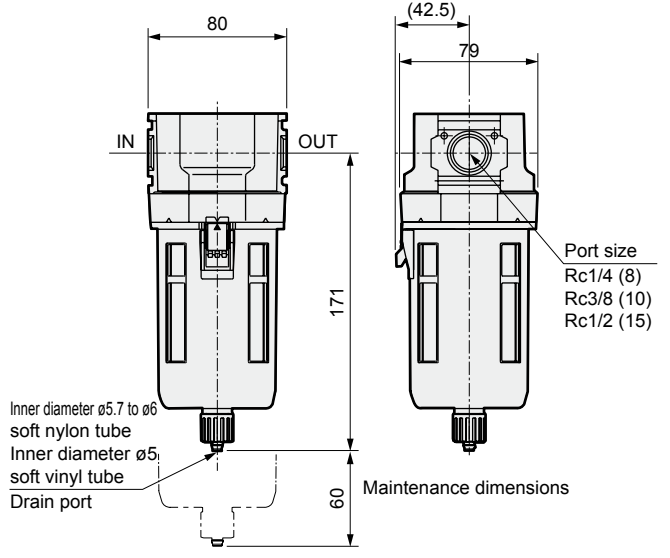

● Regarding the plastic bowl, the same dimensions apply for the type with manual cock or automatic drain.

● Metal bowl (option)

Metal manual cock
 With automatic drain (F1M)

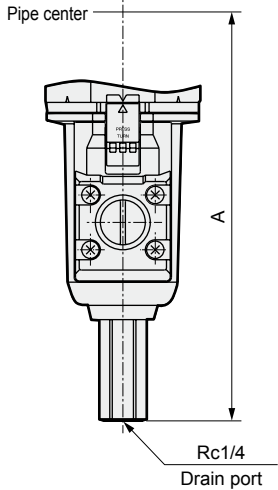

With petcock (M)

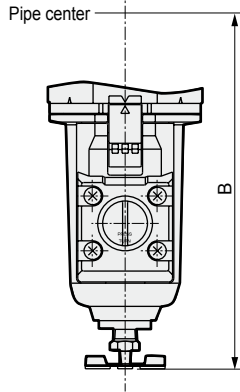

Standard manual drain cock (M1)

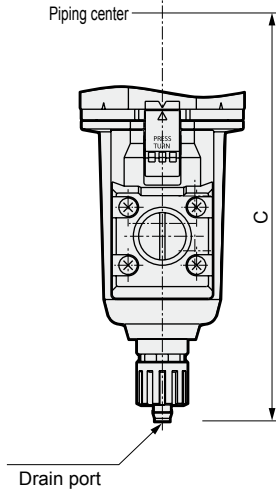

Dimensions table

Model no.	F1M	M	M1
	A	B	C
MX3000	164	143.5	154
MX4000	187	166.5	177

Refer to "Modular type F.R.L. (No. CC-962)" for details on specifications and internal structure.



Regulator Standard white series

R1000/R2000/R3000/R4000-W Series

Compact pressure gauge embedded.

Port size: Rc1/8 to Rc1/2

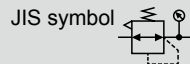

R1000	R2000
Face to face 40mm	Face to face 50mm
R3000	R4000
Face to face 63mm	Face to face 80mm

How to order

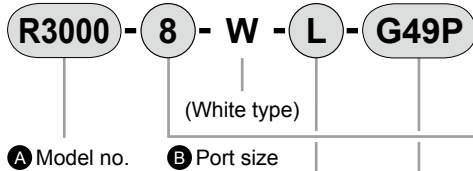

A Model no.			
R	R	R	R
1	2	3	4
0	0	0	0
0	0	0	0

Symbol	Descriptions	R1000	R2000	R3000	R4000
B Port size					
6	Rc1/8	●			
8	Rc1/4	●	●	●	●
10	Rc3/8		●	●	●
15	Rc1/2				●

C Option		Note 1				
Pressure range	Blank	0.05 to 0.85MPa	●	●	●	●
	L	0.05 to 0.35MPa	●	●	●	●
Relief	Blank	With relief mechanism	●	●	●	●
	N	Non-relief type	●	●	●	●
Pressure gauge	Blank	With standard pressure gauge (G401)	●	●	●	●
	T	Without pressure gauge (gauge port assembled sealed)	●	●	●	●
	T8	Compatibility with round shaped pressure gauge option (pressure gauge mounting port assembled open)	●	●	●	●
	T6 ^{Note 2}	Compatibility with digital pressure sensor PPX	●	●	●	●
Flow direction	Blank	Standard flow (left to right)	●	●	●	●
	X1	Reverse flow (right to left)	●	●	●	●

D Attachment		R1000	R2000	R3000	R4000
Blank	Not included	●	●	●	●
G49P	G49D-8-P10 (L: G49D-8-P04)	●	●	●	●
G59P	G59D-8-P10 (L: G59D-8-P04)	●		●	●
G40P	G40D-8-P10 (L: G40D-8-P04)	●	●	●	●
G50P	G50D-8-P10 (L: G50D-8-P04)	●		●	●
G41P	G41D-8-P10 (L: G41D-8-P04)	●	●	●	●
G52P	G52D-8-P10 (L: G52D-8-P10)	●	●	●	●
R2 ^{Note 2}	Digital pressure sensor: PPX-R10N-6M	●	●	●	●

⚠ Cautions for model No. selection

Note 1: When selecting options for several items, list options in order from the top.

Note 2: When option "T6" is selected, only "Blank" or "R2" can be selected for the pressure gauge (included). The digital pressure sensor PPX mounting port (Rc1/8) is assembled ventilated.

Note 3: The pressure switch with R1 indicator is black.

Refer to "Modular type F.R.L. (No. CC-962)" for details on specifications and internal structure.

Dimensions

● R1000

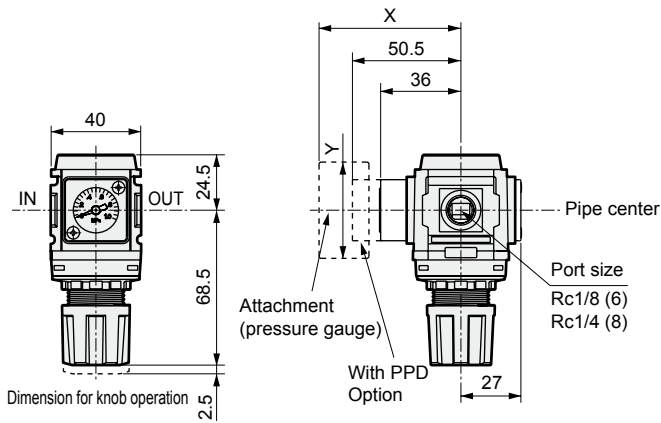

● R2000

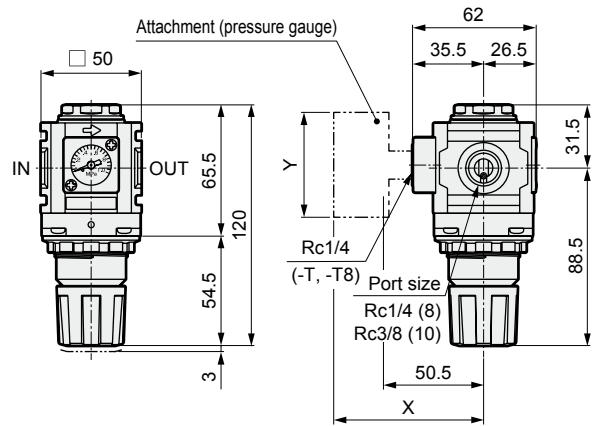

● R3000

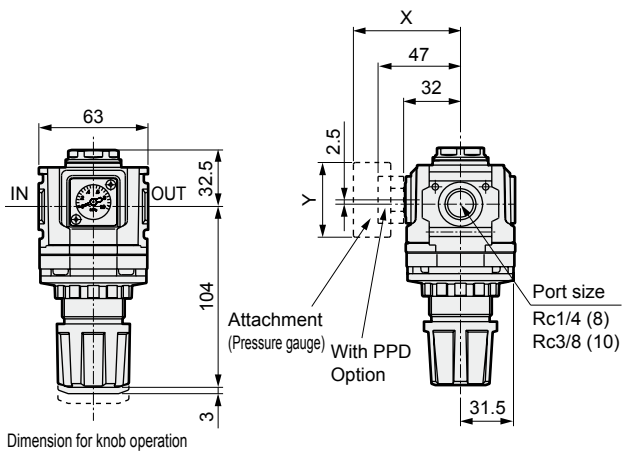

● R4000

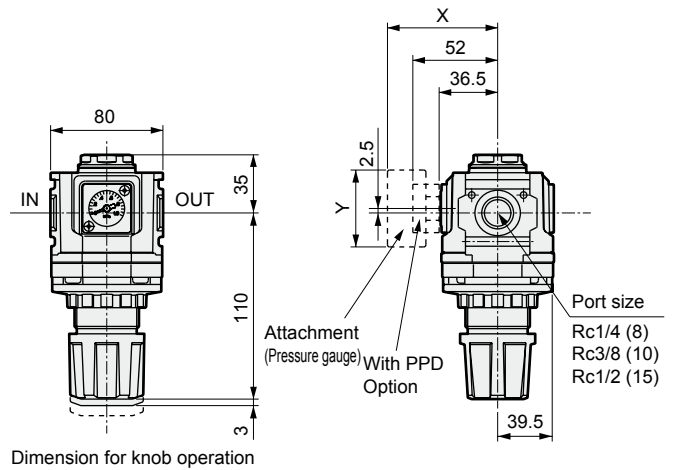

Option dimensions with pressure gauge included

Attached pressure gauge	X				Y			
	R1000	R2000	R3000	R4000	R1000	R2000	R3000	R4000
G49P	(73.5)	(73)	(69.5)	(74.5)	ø43.5	ø43.5	ø43.5	
G59P	(76)	-	(72)	(77)	ø52	-	ø52	
G40P	(75.5)	(75)	(71.5)	(76.5)	ø42.5	ø42.5	ø42.5	
G50P	(75.5)	-	(71.5)	(76.5)	ø52.5	-	ø52.5	
G41P	(74)	(73.5)	(70)	(75)	ø42	ø42	ø42	
G52P	(86)	(85.5)	(82)	(86)	ø52.5	ø52.5	ø52.5	
R2	(74)	(73)	(69.5)	(75)	□ 30	□ 30	□ 30	



Reverse regulator Standard white series

R1100/R2100/R3100/R4100-W Series

From secondary pressure to primary pressure with back flow function.

Port size: Rc1/8 to Rc1/2

JIS symbol

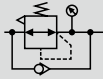

R1100	R2100
Face to face 40mm	Face to face 50mm
R3100	R4100
Face to face 63mm	Face to face 80mm

How to order

R3100 - **8** - **W** - **L** - **G49P**

A Model no.

B Port size

C Option

D Attachment

A Model no.			
R1100	R2100	R3100	R4100
●	●	●	●

Symbol	Descriptions	R1100	R2100	R3100	R4100
B Port size					
6	Rc1/8	●			
8	Rc1/4	●	●	●	●
10	Rc3/8		●	●	●
15	Rc1/2				●

C Option		Note 1, Note 2				
Pressure range	Blank	0.05 to 0.85MPa	●	●	●	●
	L	0.05 to 0.35MPa	●	●	●	●
Relief	Blank	With relief mechanism	●	●	●	●
	N	Non-relief type	●	●	●	●
Pressure gauge	Blank	With standard pressure gauge (G401)	●	●	●	●
	T	Without pressure gauge (gauge port assembled sealed)	●	●	●	●
	T8	Compatibility with round shaped pressure gauge option (pressure gauge mounting port assembled open)	●	●	●	●
	T6 ^{Note 3}	Compatibility with digital pressure sensor PPX	●	●	●	●
Flow direction	Blank	Standard flow (left to right)	●	●	●	●
	X1	Reverse flow (right to left)	●	●	●	●

D Attachment		R1100	R2100	R3100	R4100
Blank	Not included	●	●	●	●
G49P	G49D-8-P10 (L: G49D-8-P04)	●	●	●	●
G59P	G59D-8-P10 (L: G59D-8-P04)	●		●	●
G40P	G40D-8-P10 (L: G40D-8-P04)	●	●	●	●
G50P	G50D-8-P10 (L: G50D-8-P04)	●		●	●
G41P	G41D-8-P10 (L: G41D-8-P04)	●	●	●	●
G52P	G52D-8-P10 (L: G52D-8-P10)	●	●	●	●
R2 ^{Note 3}	Digital pressure sensor: PPX-R10N-6M	●	●	●	●

⚠ Cautions for model No. selection

Note 1: When selecting options for several items, list options in order from the top.

Note 2: Position of the check valve and pressure gauge can not be changed. If the reverse direction of IN and OUT are required, indicate "X1" in the end of optional section.

Note 3: When option "T6" is selected, only "Blank" or "R2" can be selected for the pressure gauge (included). The digital pressure sensor PPX mounting port (Rc1/8) is assembled ventilated.

Note 4: The pressure switch with R1 indicator is black.

Refer to "Modular type F.R.L. (No. CC-962)" for details on specifications and internal structure.

Dimensions

● R1100

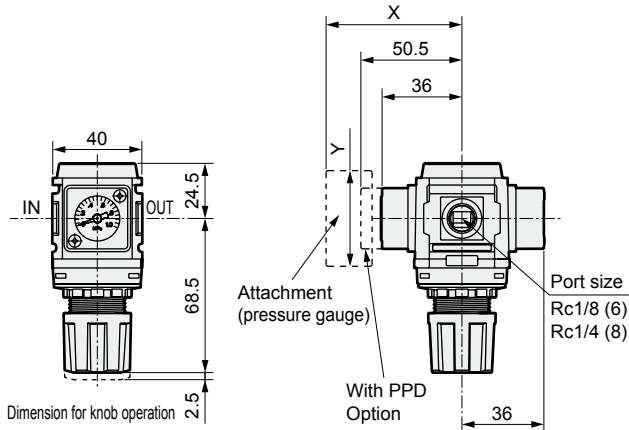

● R2100

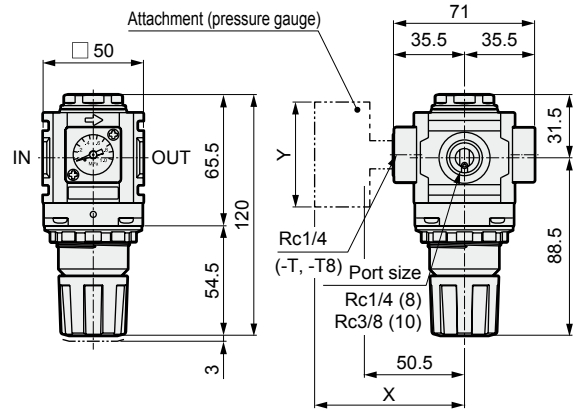

● R3100

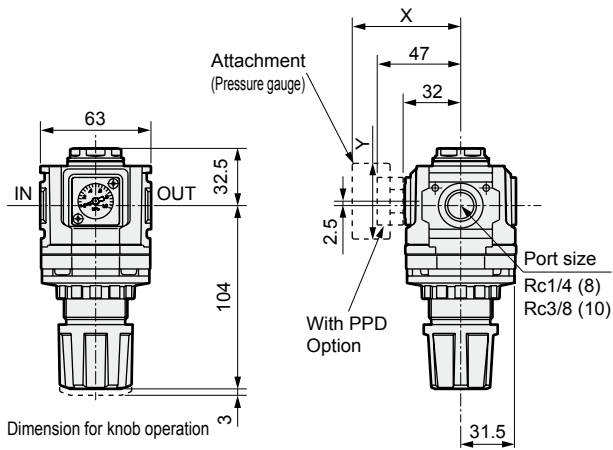

● R4100

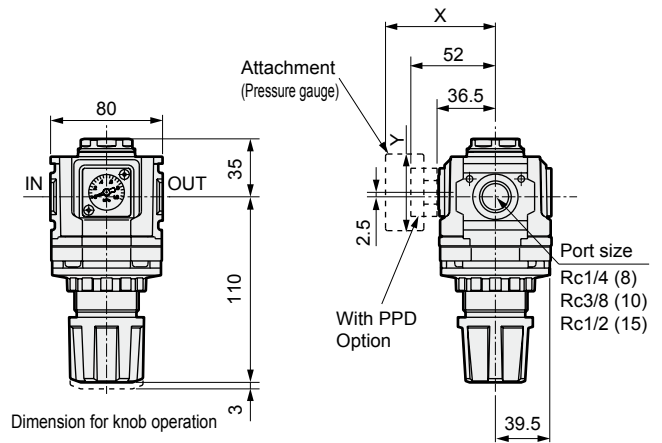

Option dimensions with pressure gauge included

Attached pressure gauge	X				Y			
	R1000	R2000	R3000	R4000	R1000	R2000	R3000	R4000
G49P	(73.5)	(73)	(69.5)	(74.5)	ø43.5	ø43.5		ø43.5
G59P	(76)	-	(72)	(77)	ø52	-		ø52
G40P	(75.5)	(75)	(71.5)	(76.5)	ø42.5	ø42.5		ø42.5
G50P	(75.5)	-	(71.5)	(76.5)	ø52.5	-		ø52.5
G41P	(74)	(73.5)	(70)	(75)	ø42	ø42		ø42
G52P	(86)	(85.5)	(82)	(86)	ø52.5	ø52.5		ø52.5
R2	(74)	(73)	(69.5)	(75)	□ 30	□ 30		□ 30

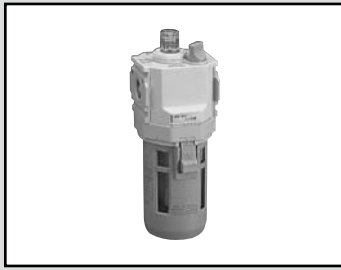

Lubricator Standard white series

L1000/L3000/L4000-W Series

Supply fine mist oil.
Port size: Rc1/8 to Rc1/2

JIS symbol



L1000

Face to face
40mm

L3000

Face to face
63mm

L4000

Face to face
80mm

How to order

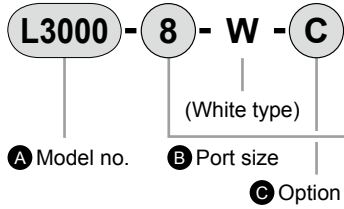

A Model no.		
L	L	L
1	3	4
0	0	0
0	0	0

Symbol	Descriptions			
B Port size				
6	Rc1/8	●		
8	Rc1/4	●	●	●
10	Rc3/8		●	●
15	Rc1/2			●

⚠ Cautions for model No. selection

Note 1: When selecting options for several items, list options in order from the top.

Note 2: The adjusting dome is made of polycarbonate for a nylon bowl or metal bowl. Consult with CKD if a different material is required.

C Option					
Drainage	Blank	No manual cock	●	●	●
	C	With manual cock	●	●	●
	LL	With float switch		●	●
Bowl material	Blank	Polycarbonate bowl	●	●	●
	Z	Nylon bowl	●	●	●
	M	Metal bowl		●	●
Flow direction	Blank	Standard flow (left to right)	●	●	●
	X1	Reverse flow (right to left)	●	●	●

Drain discharge and bowl material combination ("C" in How to order) ● Option With float switch

3000, 4000 Series			
Shape			
		Plastic bowl	Metal bowl
Material	Polycarbonate	Nylon	Aluminum
	Lubricator L*000	LL	LLZ

Dimensions

● L1000

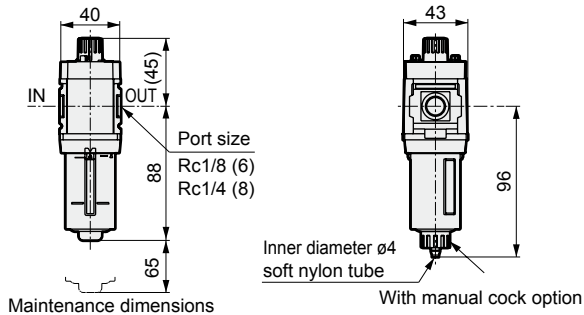

● L3000

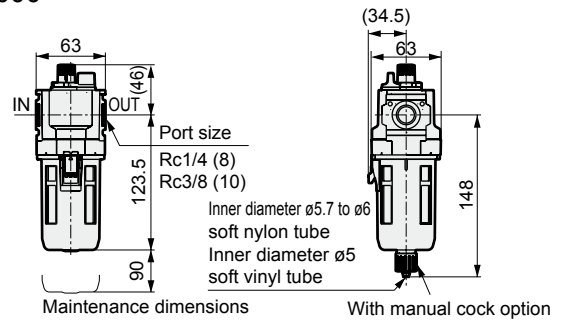

● L4000

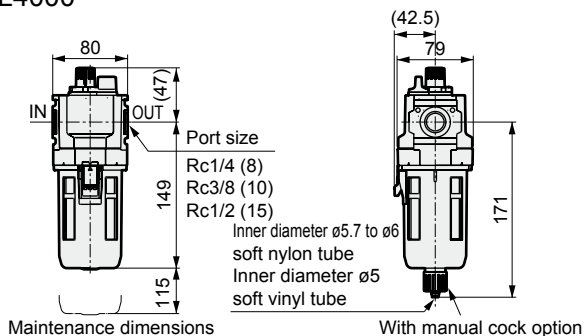

Refer to "Modular type F.R.L. (No. CC-962)" for details on specifications and internal structure.

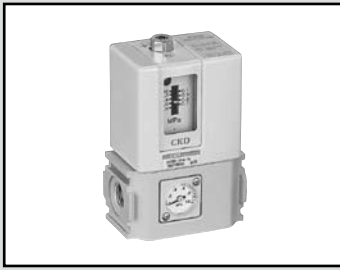

Mechanical pressure switch Standard white series

P4000-W Series

Wide pressure setting range covers 0.1 to 0.8 MPa.

Port size: Rc1/4 to Rc1/2

JIS symbol

Face to face
80mm



Custom
order only

How to order

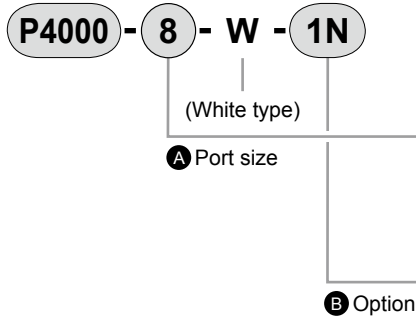

Symbol	Descriptions
A Port size	
8	Rc1/4
10	Rc3/8
15	Rc1/2
B Option	
Blank	Without indicator light
1N	100/200 VAC with indicator light
3N	24 VDC with indicator light
T	Without pressure gauge

* Model no. for custom order only.
Can not be purchased individually.

Dimensions

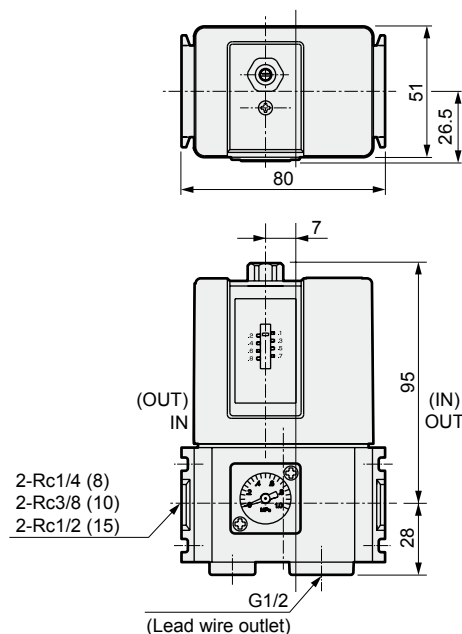

Refer to F.R.L. unit section on "Pneumatic, Vacuum and Auxiliary Components (No. CB-024S)" for specifications, internal structure and safety precautions.



Reed switch type compact mechanical pressure switch

P1100·P4100-UN-Series

Modular design with F.R.L.

JIS symbol



P1100

Face to face
28mm

P4100

Face to face
31.5mm



Custom
order only

How to order (modular connection compatible)

P **4100** - **UN** - **6** - **W** - **L** - **3**

(White type)

A Series model no/

B Port size

* Model no. for custom order only.
Can not be purchased individually.

C Branching direction

D Lead wire length

Symbol	Descriptions	
A Series model no/		
1100	For CXU10 Series	
4100	For CXU30, CXU40 Series	
B Port size		
	1100	4100
6	Rc1/8	●
8	Rc1/4	●
10	Rc3/8	●
15	Rc1/2	●
C Branching direction Note 1		
Blank Note 2	L	R
D Lead wire length		
Blank	1m	
3	3m	
5	5m	

⚠ Cautions for model No. selection

Note 1: This is used for intermediate connection of the module series so the module connection section is not threaded.

Note 2: A masking plug matching the port size is enclosed.

Dimensions

● P1100

● P4100

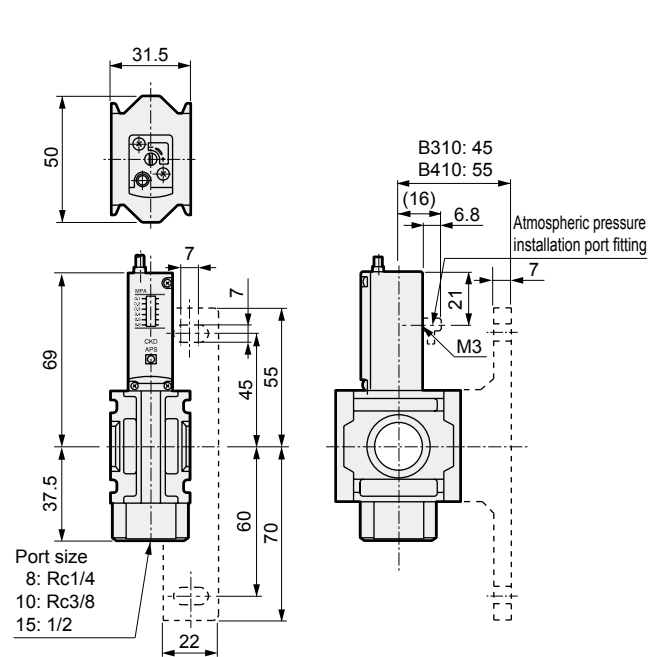
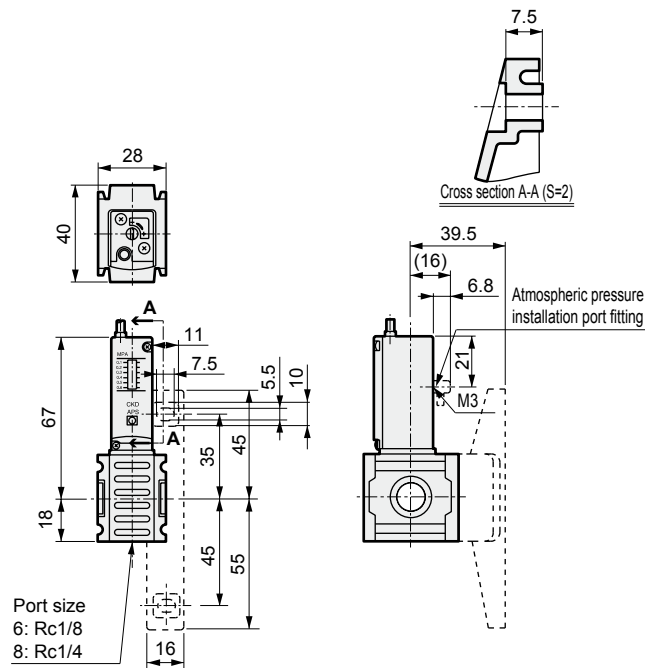

Weight 126g

Weight 190g

MEMO

Valve air unit

Air unit component

Custom air unit

Handled as a custom order



Shut-off valve Standard white series

V1000·V3000-W Series

1 action exhaust operation, prevent accidents caused by residual pressure.
Port size: Rc1/8 to Rc1/2

JIS symbol

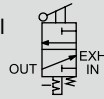

How to order

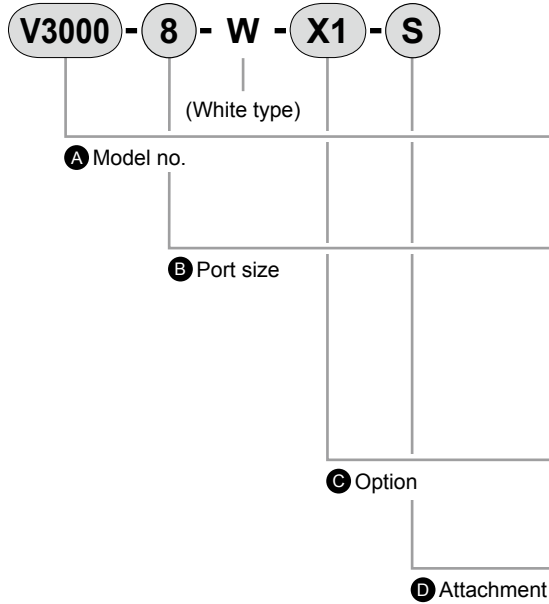

Symbol	Descriptions		
A Model no.			
V1000	For CXU10 Series		
V3000	For CXU30, CXU40 Series		
B Port size			
		V1000	V3000
6	Rc1/8	●	
8	Rc1/4	●	●
10	Rc3/8		●
15	Rc1/2		●
C Option			
Blank	None		
X1	IN/OUT reverse flow (right to left)		
D Attachment			
Blank	Not included		
S	Silencer		

Dimensions

● V1000

● V3000

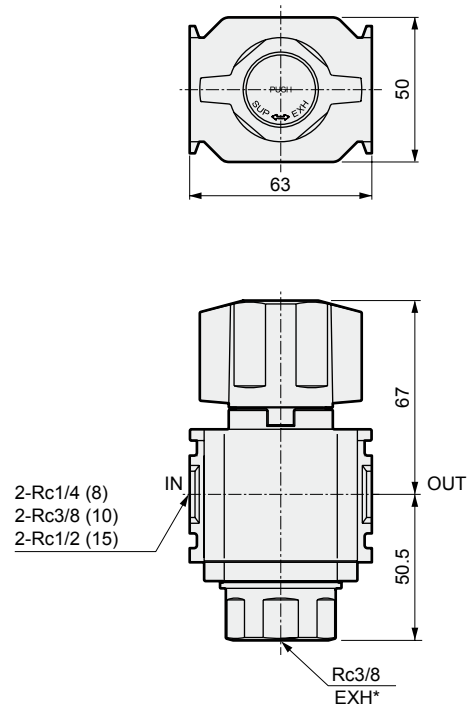
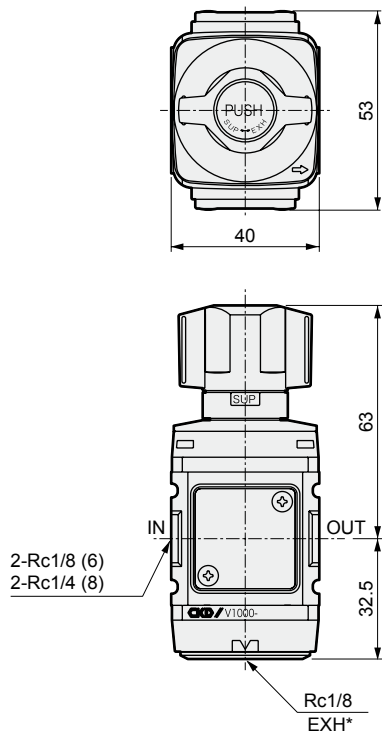

* The EXH port is dedicated for installation of the silencer.

* The EXH port is dedicated for installation of the silencer.

Refer to "Modular type F.R.L. (No. CC-962)" for details on specifications and internal structure.

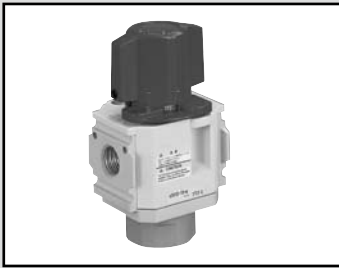

Lockout valve (OSHA compliant)

V3010-W Series

Prevent accidents caused by residual pressure.

Port size: 1/4 to 1/2

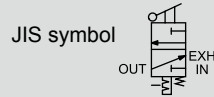

OSHA (Occupational Safety and Health Administration)

OSHA established US Safety Standards related to related to worker safety.

<Regulations for lockout / tagout >

When servicing or maintaining machinery, the air source shall be closed with a shut-off valve (lockout valve), and residual pressure shall be discharged. If a third party inadvertently operates the valve during such operation and compressed air is applied, the cylinder, etc., could move suddenly and injure personnel. This standard states that, "All valves used for such purposes shall have a key or a structure which can be locked with a key."

How to use

● Regular use

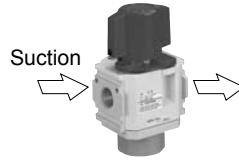

● Maintenance work

Locks can be applied where residual pressure is discharged.

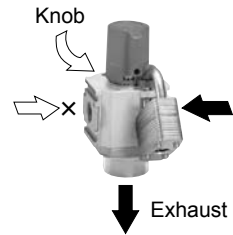

How to order

V3010 - **8** - **W** - **X1** - **S**

(White type)

A Port size

B Option

C Attachment
Note 2

Symbol	Descriptions
A Port size	
8	Rc1/4
10	Rc3/8
15	Rc1/2
B Option	
Blank	Standard flow (left to right)
X1	IN/out reverse flow (right to left)
C Attachment	
Blank	No attachments
S	Silencer

⚠ Cautions for model No. selection

Note 1: Consult with CKD for applying the lock at the air supply position.

Note 2: Silencer element is not flame resistant.

Dimensions

● V3010

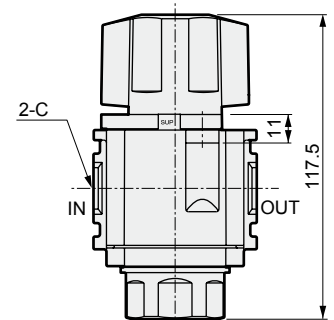
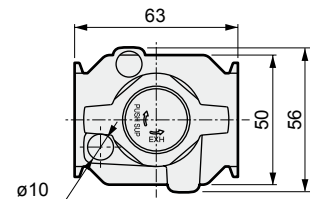

EXH Rc3/8

* The EXH port is dedicated for installation of the silencer.

Descriptions	C
V3010-8-W	Rc1/4
V3010-10-W	Rc3/8
V3010-15-W	Rc1/2

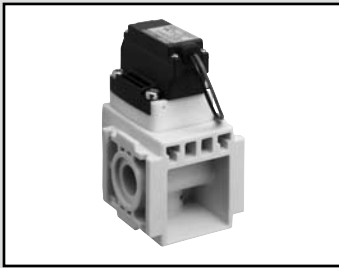

2 port pilot operated solenoid valve for compressed air

CXU10-EXA-UN Series

N.C. (normally closed) type, diaphragm structure type
 Modular connection with 1000 Series
 Ideal for modular component blow valves

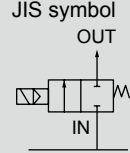

Screw free
open type

IN
Gasket

Expandable

How to order

CXU10-EXA - UN - C6 - 2C - 1

A Port size (OUT)

B Coil option

C Voltage

* Model no. for custom order only.
 Can not be purchased individually.
 Refer to page 14 for the model no.
 of your order.

⚠ Cautions for model No. selection

Coil Option	Voltage	
	1	3
2C	●	●
2H	●	
2HS		●

Select from the circle mark above.

Symbol	Descriptions	
A Port size (OUT)		
C6	ø6 push-in fitting	
CL6	ø6 push-in fitting L type	
C8	ø8 push-in fitting	
CL8	ø8 push-in fitting L type	
B Coil option Note 1		
2C	Standard	Lead wire (without indicator light and surge suppressor)
2H	Option	DIN terminal box (Pg7), with indicator light inside terminal box
2HS		DIN terminal box (Pg7), with indicator light and surge suppressor inside terminal box
C Voltage Note 1		
1	100VAC	
3	24 VDC	

Note 1: Refer to the table on the left for available combinations of coil options and voltage.

Dimensions

● Grommet lead wire type
 CXU10-EXA-UN-* -2C-*
 Cartridge fitting: straight type

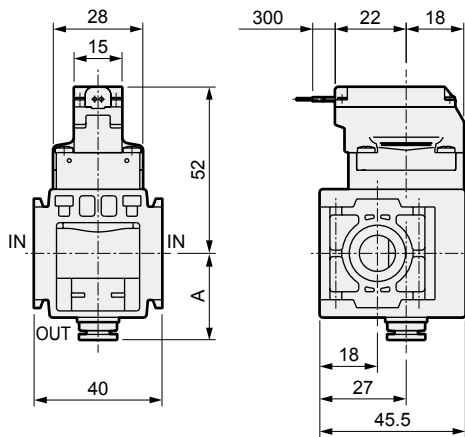

● With DIN terminal box type (Pg7) type
 CXU10-EXA-UN-* -2HS-*

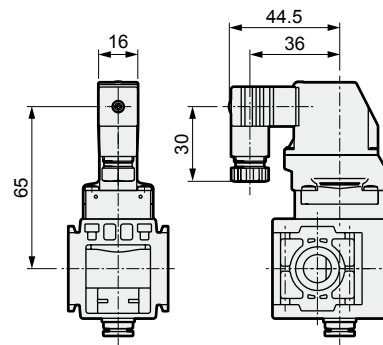

Elbow type fitting

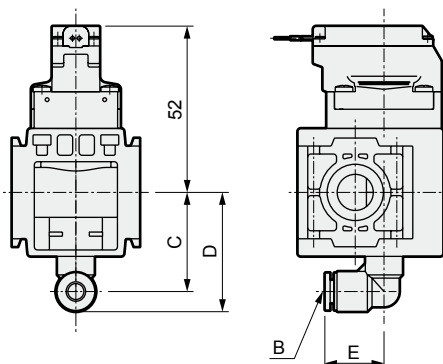

Option dimensions

Option	A	B	C	D	E
C6	27	ø6 push-in fitting	-	-	-
CL6	-	ø6 push-in fitting	31	37	18.5
C8	27	ø8 push-in fitting	-	-	-
CL8	-	ø8 push-in fitting	32	39	21



2 port direct acting solenoid valve

CXU10-FAB3-UN Series

NC (normally closed)

Modular connection with 1000 Series

Ideal for modular component blow valves

JIS symbol

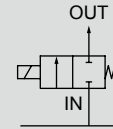

Screw free open type

Both sides 40mm



Custom order only

How to order

CXU10-FAB3 - UN - C6 - 2C - 3



A Port size (OUT)

B Coil option

C Rated voltage

Symbol	Descriptions
A Port size (OUT)	
C6	ø6 push-in fitting
CL6	ø6 push-in fitting L type
C8	ø8 push-in fitting
CL8	ø8 push-in fitting L type
B Coil option	
2C	Grommet lead wire
2HS	DIN terminal box with light, surge suppressor (Pg11)
C Rated voltage	
1	100 VAC 50/60Hz, 110 VAC 60Hz
3	24 VDC

* Model no. for custom order only.
Can not be purchased individually.
Refer to page 16 for the model no. of your order.

Dimensions

● Grommet lead wire type
CXU10-FAB3-UN-* -2C-*
Cartridge fitting: straight type

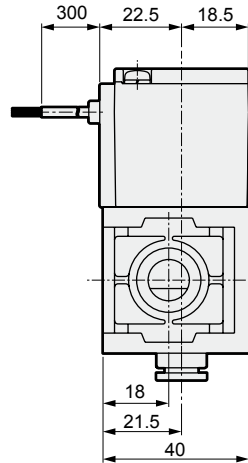
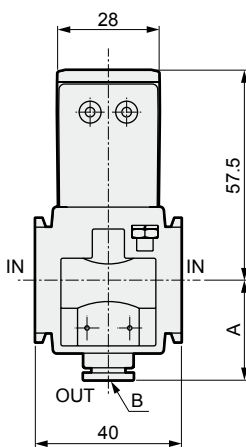

● With DIN terminal box (Pg7) type
CXU10-FAB3-UN-* -2HS-*

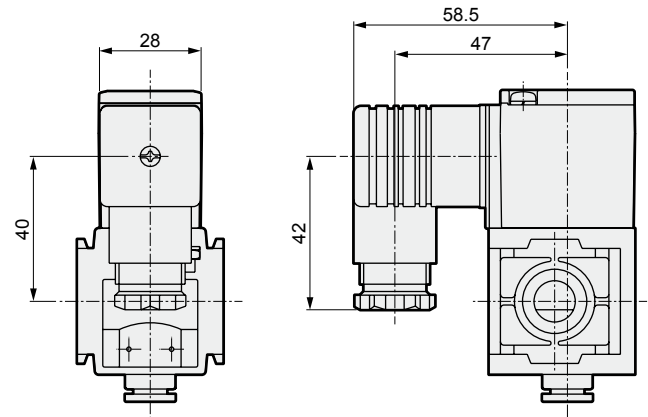

Elbow type fitting

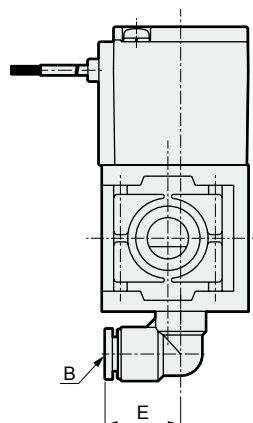
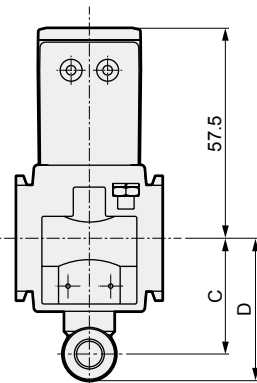

Option dimensions

Option	A	B	C	D	E
C6	27	ø6 push-in fitting	-	-	-
CL6	-	ø6 push-in fitting	31	37	18.5
C8	27	ø8 push-in fitting	-	-	-
CL8	-	ø8 push-in fitting	32	39	21



2 port direct acting solenoid valve

CXU30-FAB4U-UN Series

NC (normally closed)

Modular connection with 3000 Series

JIS symbol

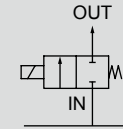

Face to face
50mm

No screw
Open type

Custom
only

How to order

CXU30-FAB4U-UN-8L-2C-3

A Coil option

B Rated voltage

* Model no. for custom order only.
Can not be purchased individually.
Refer to page 18 for the model no.
of your order.

Symbol	Descriptions
A Coil option	
2C	Grommet lead wire
2HS	DIN terminal box with light, surge suppressor (Pg11)
B Rated voltage	
1	100 VAC 50/60Hz, 110 VAC 60Hz
3	24 VDC

Dimensions

● Grommet lead wire type
CXU30-FAB4U-UN-8L-2C-*

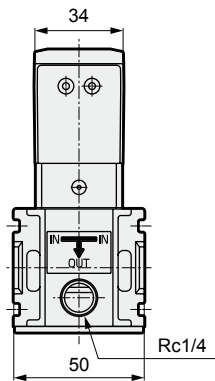
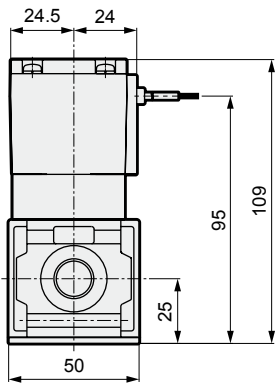

● With DIN terminal box (Pg7) type
CXU30-FAB4U-UN-8L-2HS-*

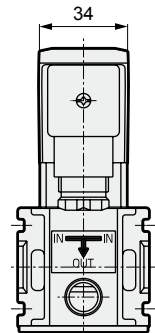
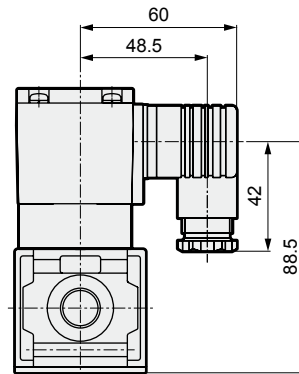

Refer to air unit components page 18 for specifications and internal structure dimensions.

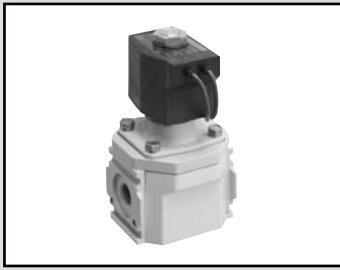

2 port pilot kick solenoid valve

CXU30-ADK-UN Series

NC (normally closed)

Diaphragm structure

Modular connection with 3000 Series

Suitable as modular component master valves

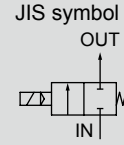

Face to face
63mm

Custom
order only

How to order

CXU30-ADK-UN-00-F**-**2C**-**3****

A Selant

B Coil option

C Rated voltage

* Model no. for custom order only.
Can not be purchased individually.
Refer to page 20 for the model no.
of your order.

Symbol	Descriptions
A Selant	
Blank	Nitrile rubber
F	Fluoro rubber
B Coil option	
2C	Grommet lead wire * 1
2HS	DIN terminal box with light, surge suppressor (Pg11)
C Rated voltage	
1	100 VAC 50/60Hz, 110 VAC 60Hz
3	24 VDC

* 1: Coil option 2C is available for rated voltage **[1]** only.

Dimensions

● Grommet lead wire type
CXU30-ADK-UN-00-* 2C-*

● With DIN terminal box (Pg7) type
CXU30-ADK-UN-00-* 2HS-*

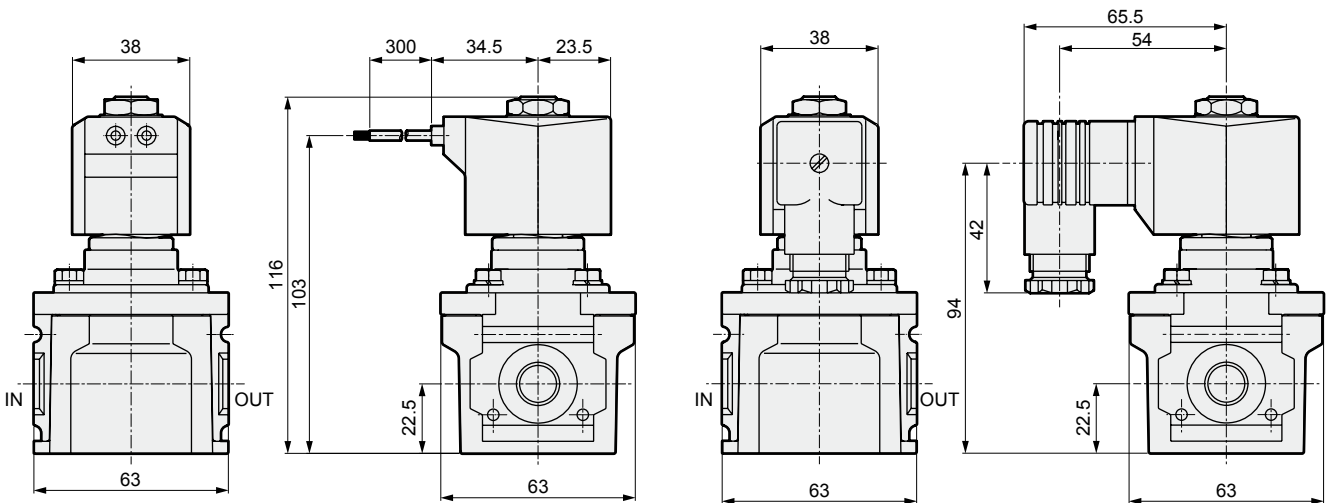

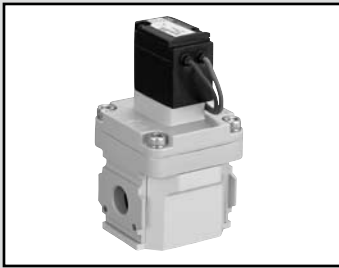

2 port pilot operated solenoid valve

CXU30-FAD-UN Series

NC (normally closed)
 Diaphragm structure
 Modular connection with 3000 Series
 Suitable as modular component master valves

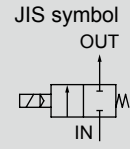

Face to face
63mm

Custom
order only

No screw
Open type

How to order

CXU30-FAD-UN-00- **A** - **B** - **C**

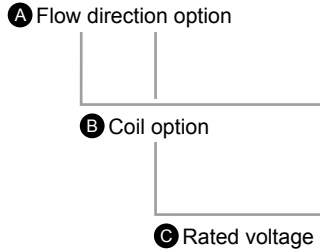

* Model no. for custom order only.
 Can not be purchased individually.
 Refer to page 22 for the model no.
 of your order.

Symbol	Descriptions
A Flow direction option	
Blank	Standard flow (left to right)
X1	Reverse flow (right to left)
B Coil option	
2C	Grommet lead wire
2HS	DIN terminal box with light, surge suppressor (Pg11)
C Rated voltage	
1	100 VAC 50/60Hz, 110 VAC 60Hz
3	24 VDC

Note 1: Depending on use, such as using with an extremely small flow rate or when the solenoid valve's secondary side is restricted, operation may be unstable at pressure differences less than 0.1 MPa.

Dimensions

● Grommet lead wire type
 CXU30-FAD-UN-00-2C-*

● With DIN terminal box (Pg7) type
 CXU30-FAD-UN-00-2HS-*

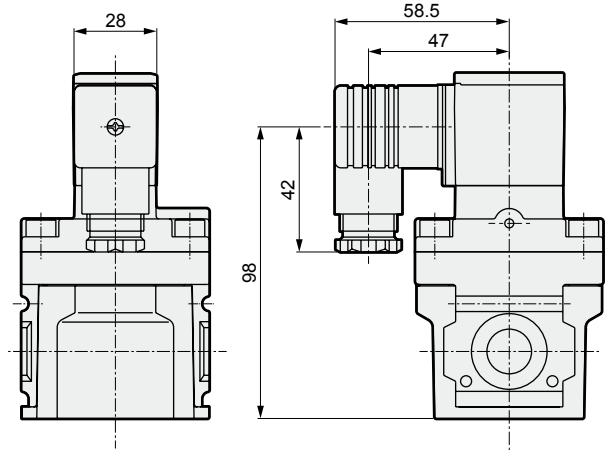
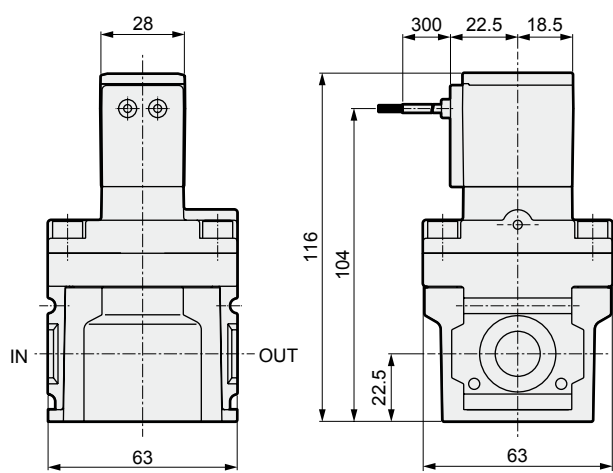

Refer to FAD Series on "General Purpose Valves (No. CB-03-1S)" for specifications and internal structure.

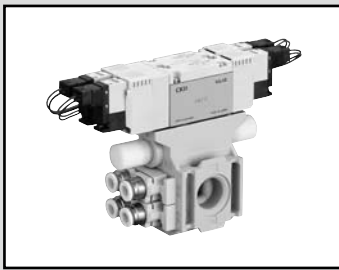

5 port pilot operated valve

CXU30-4G2-UN Series

5 port solenoid valve for modular connection with 3000 Series

Face to face
56mm

Custom
order only

No screw
Open type

How to order

CXU30-4G2-UN- 3 3 -C6- E20 S - 3

A Model no.

B Solenoid valve ①, solenoid position Note 4, 5

C Solenoid valve ②, solenoid position Note 4, 5

D Port size (OUT)

E Electric connection

F Option

G Rated voltage

* Model no. for custom order only.
Can not be purchased individually.
Refer to page 24 for the model no.
of your order.

⚠ Cautions for model No. selection

- Note 1: GWS*-8-S fittings can be mounted on the R1 port.
- Note 2: Check valve is provided as standard. The 3 position all ports closed and P/A/B connection cannot be used with the check valve.
- Note 3: If port size, wire connection, option or voltage is different for solenoid valve ① ②, the product will be processed as a customized order.
- Note 4: Refer to dimensions drawings for positions of solenoid valves ①, ②.
- Note 5: When masking plates are used for all solenoid valves, indicated for wire connection and rated voltage options must be left blank.

Symbol	Descriptions
B Solenoid valve ① solenoid position	
0	Without solenoid valve: masking plate
1	2-position single solenoid
2	2-position double solenoid
3	3-position all ports closed
4	3-position ABR connection
5	3-position PAB connection
C Solenoid valve ② solenoid position	
0	Without solenoid valve: masking plate
1	2-position single solenoid
2	2-position double solenoid
3	3-position all ports closed
4	3-position ABR connection
5	3-position PAB connection
D Port size (OUT)	
C4	ø4 push-in fitting
C6	ø6 push-in fitting
CL6	ø6 push-in fitting L (rear)
C8	ø8 push-in fitting
E Electric connection	
B	DIN terminal box (Pg7)
E20	E connector lead wire (500mm) with surge suppressor and light
F Option	
Blank	None
S	2 silencers (SLW-8S) included
G Rated voltage	
1	100 VAC (rectified bridge integrated)
3	24 VDC

Refer to page 29 for solenoid valve model no. list.

JIS symbol

2-position single solenoid

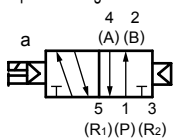

2-position double solenoid

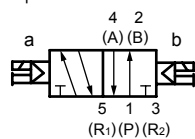

3-position all ports closed

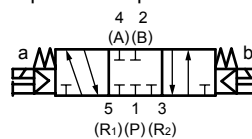

3-position ABR connection

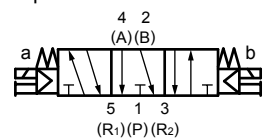

3-position PAB connection

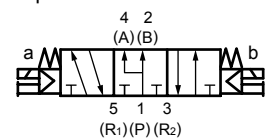

Refer to 4G Series on "Pneumatic Valves (No. CB-23SA)" for specifications and internal structure.

CXU30-4G2-UN Series

Dimensions

CXU30-4G2-0

- E connector type (E)
Cartridge fitting: straight type

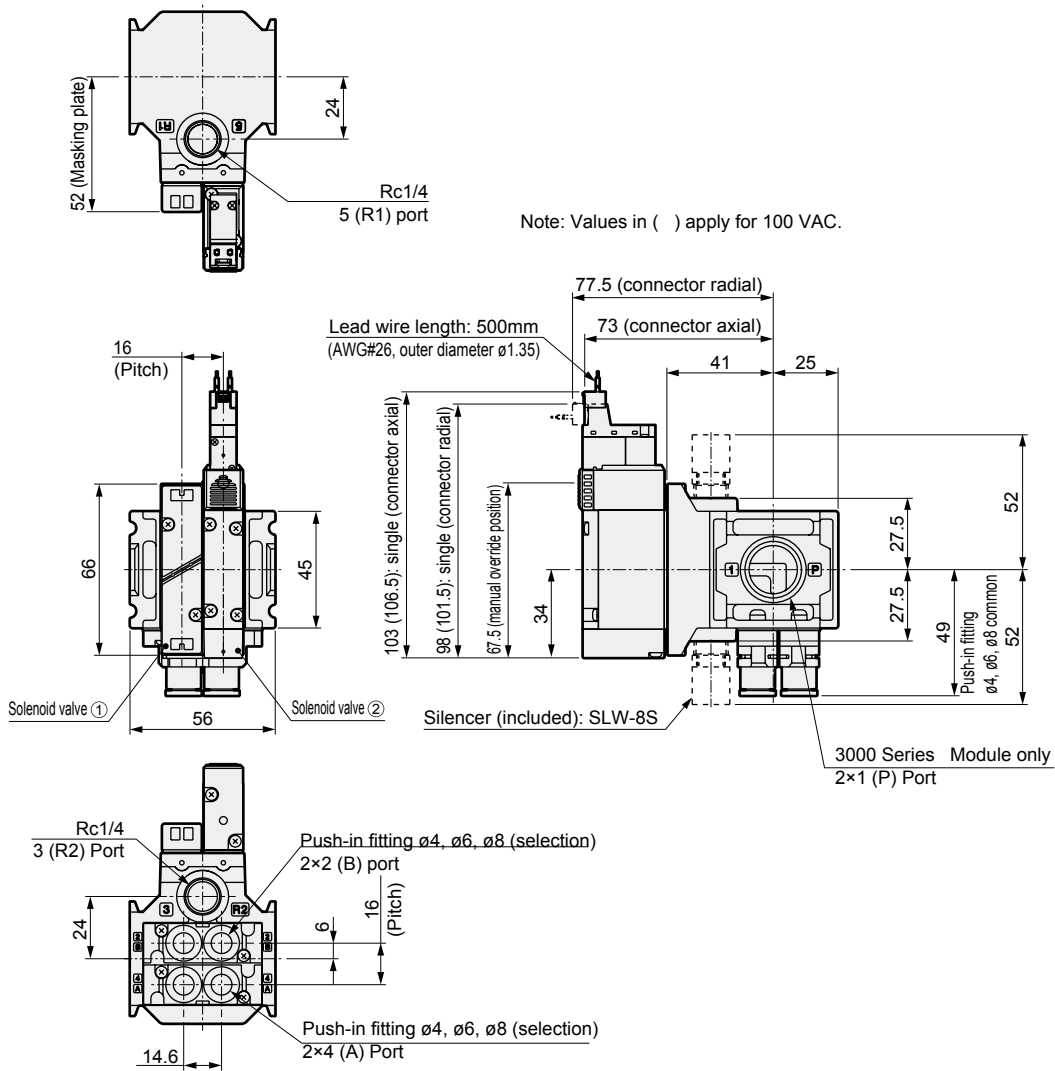

- DIN terminal box type (B)
Cartridge fitting: straight type

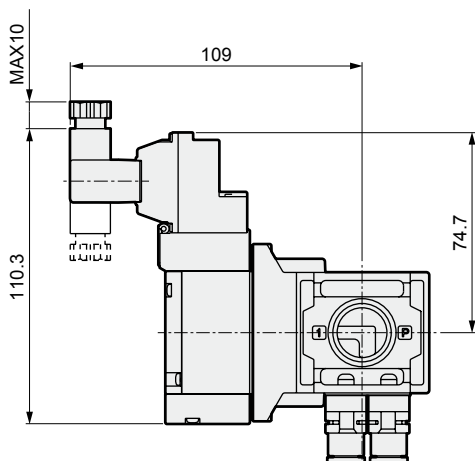

Note: The DIN terminal box assembly is shipped facing inward.

- ϕ 6 push-in fitting L (rear)

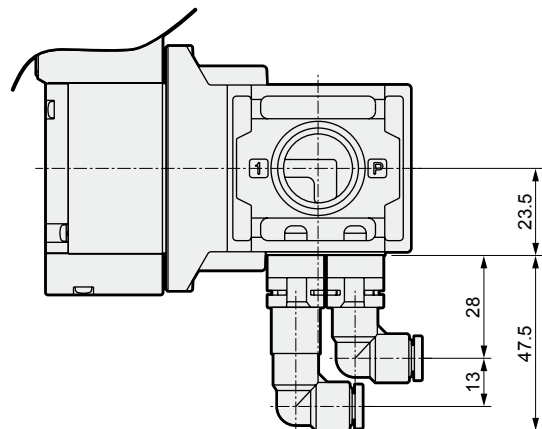

Dimensions

CXU30-4G2-_{3 4 5}

- E connector type (E)
Cartridge fitting: straight type

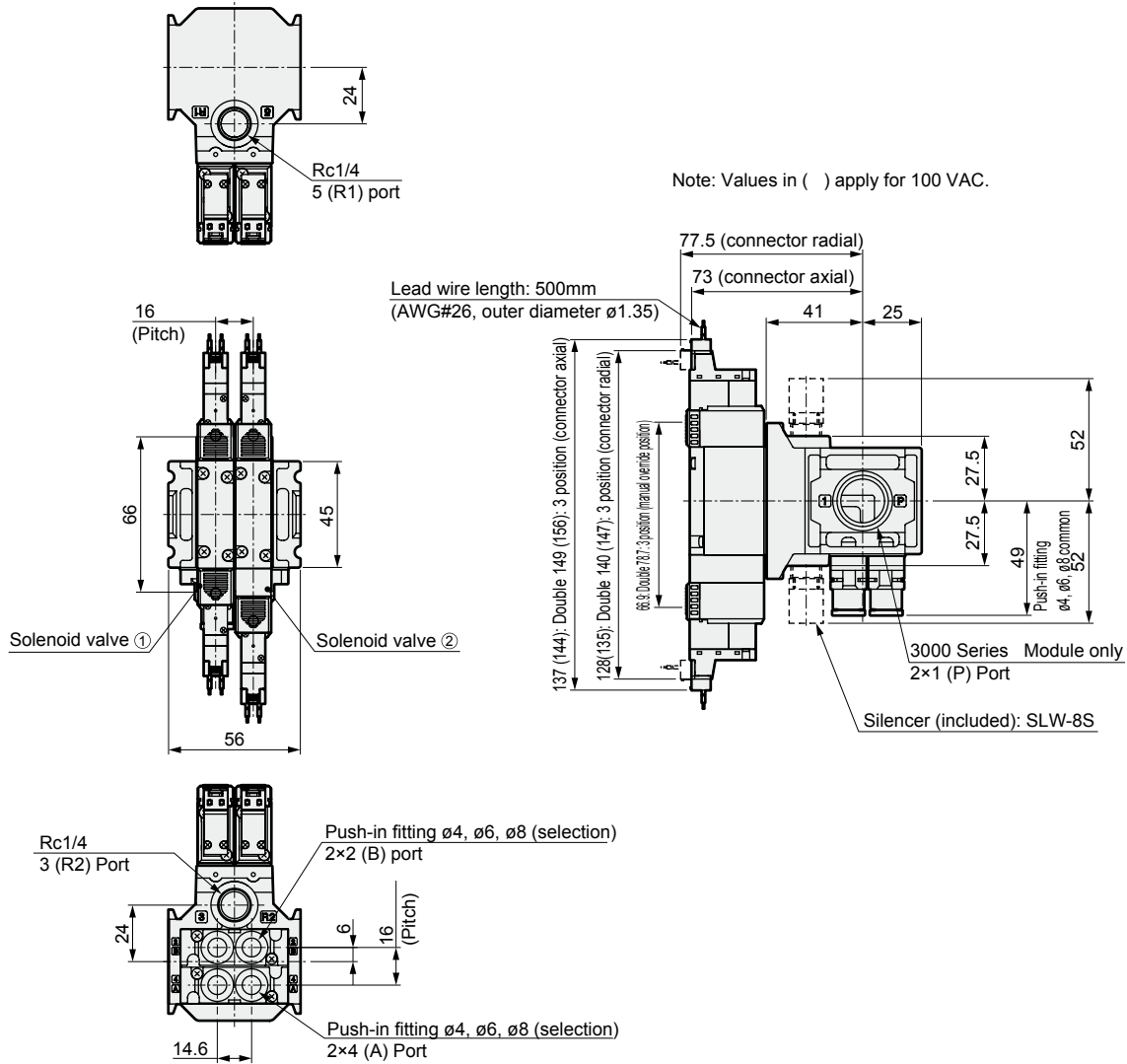

- DIN terminal box type B
Cartridge fitting: straight type

- $\phi 6$ push-in fitting L (rear)

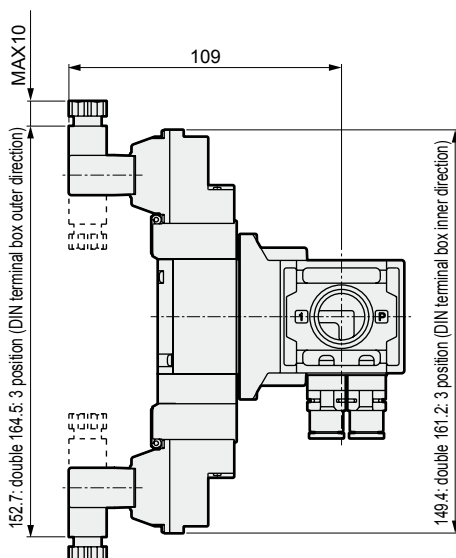

Note: The DIN terminal box assembly is shipped facing inward.

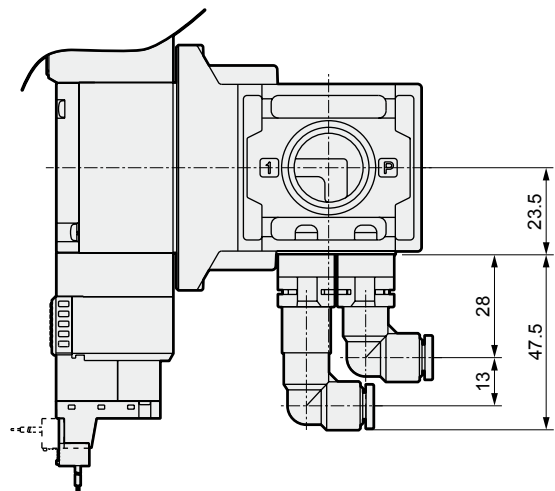

Valve air unit

Air unit component

Custom air unit

Handled as a custom order

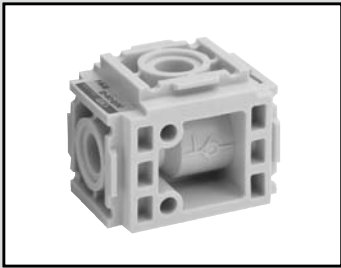

Modular check valve

CXU10-CHV-UN Series

Completely blocks reverse flow of fluid such as compressed air
 Modular connection with F.R.L. 1000 Series
 Intermediate takeout of air possible with branch port

JIS symbol

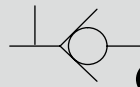

Face to face
56mm



Custom
order only

How to order

CXU10-CHV - UN - 00 - 6 - A - X1

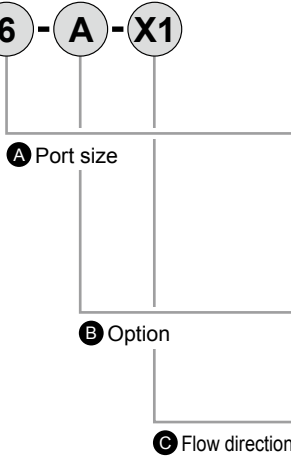

- * 1 Model no. for custom order only.
Can not be purchased individually.
Refer to page 34 for the model no. of your order.
- * 2 Piping adaptor and masking adaptor assembly is assembled on the top of the product.

Symbol	Descriptions
A Port size	
6	Piping adaptor (Rc1/8") assembled
8	Piping adaptor (Rc1/4") assembled
10	Piping adaptor (Rc3/8") assembled
MA	Masking adapter assembled
B Option	
Blank	No options
A	Fluoro rubber specification
C Flow direction	
Blank	Standard flow (left to right)
X1	Reverse flow (right to left)

Dimensions

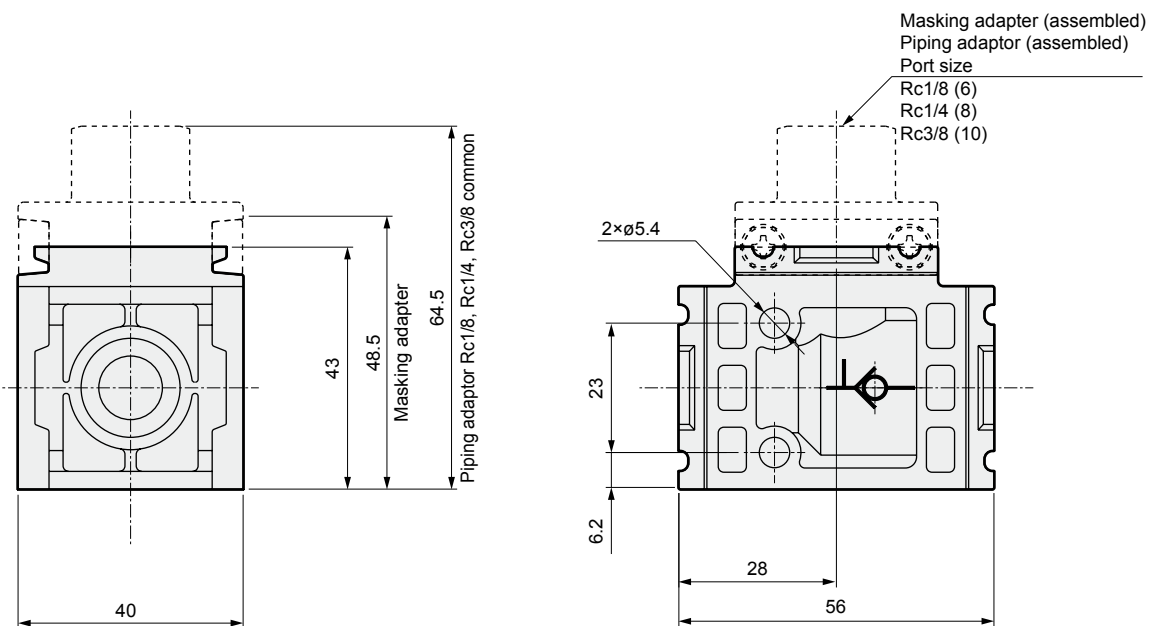

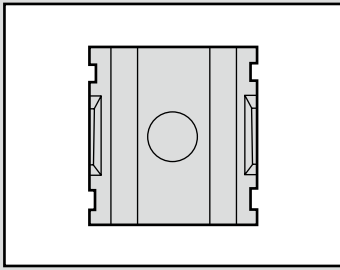

Distributor Standard white series

D401-UN-W·D300-W Series

Applicable for pipe branching.
Port size: Rc1/4 to Rc1/2

D401

Face to face
31.5mm

D300

Face to face
42mm



How to order

D101 - UN - 00 - **6** - **W**

A Model no.

(White type)

B Port size

Symbol	Descriptions	
A Model no.		
D101	For 1000 Series	
D401	For 2000, 3000, 4000 Series	
B Port size		
	D101	D401
6	1/8	●
8	1/4	●
10	3/8	●
15	1/2	●

D300 - **8** - **W** - **Q**

Distributor

(White type)

A Port size

B Option

Symbol	Descriptions	
A Port size		
8	Rc1/4	
10	Rc3/8	
B Option		
Blank	None	
Q	Includes 2 each of the following; Rc1/4 blanking plug, Rc3/8 blanking plug	

Dimensions

● D101-UN-00

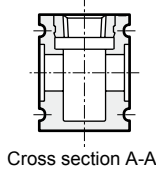
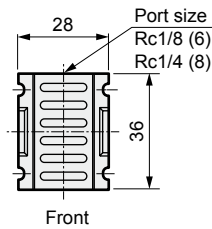
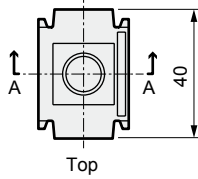

Dimensions

● D401-UN-00

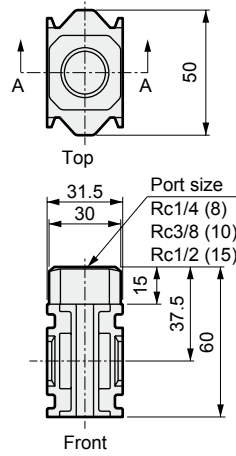

Dimensions

● D300

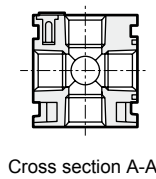
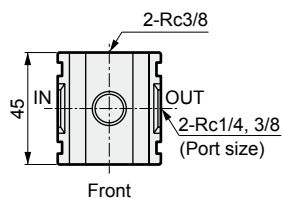
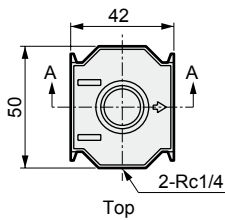

Applications (D401-00-W)



Valve air unit

Air unit component

Custom air unit

Handled as a custom order

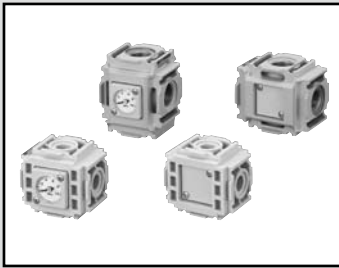

4 directional distributor

CXU10-D4-UN·CXU30-D4-UN Series

Branches the fitting section of a module up to 4 directions.
Fitting section can be mounted and removed from 1 position.
With pressure gauge mounting port.

Face to face
56mm

Custom
order only

Screw free
open type



How to order

CXU10-D4 - UN - 00 - T6

JIS symbol



A Option

Symbol	Descriptions
A Option	
Blank	Without pressure gauge port (blanking plug assembled)
T6	Pressure gauge port Rc1/8
T8	Pressure gauge port Rc1/4
G401	With pressure gauge (G401)
R1	Pressure switch with display PPD assembled

How to order

CXU30-D4 - UN - 15 - T6

JIS symbol

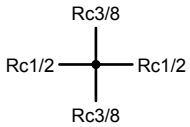

A Option

Symbol	Descriptions
A Option	
Blank	Without pressure gauge port (blanking plug assembled)
T6	Pressure gauge port Rc1/8
T8	Pressure gauge port Rc1/4
G401	With pressure gauge (G401)
R1	Pressure switch with display PPD assembled

* Model no. for custom order only.
Can not be purchased individually.
Refer to page 36 for the model no.
of your order.

Dimensions

● CXU10-D4-UN

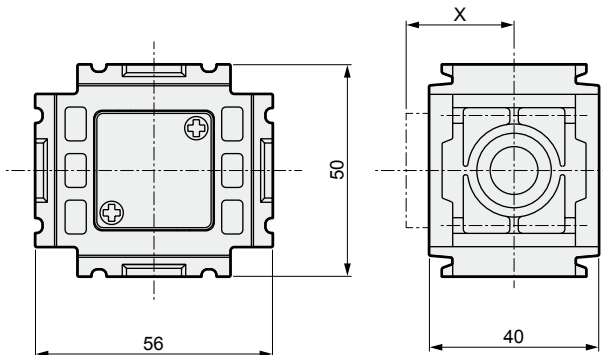

Option dimensions

Option	X
T6	25.5
T8	25.5
G401	25.5
R1	40

● CXU30-D4-UN

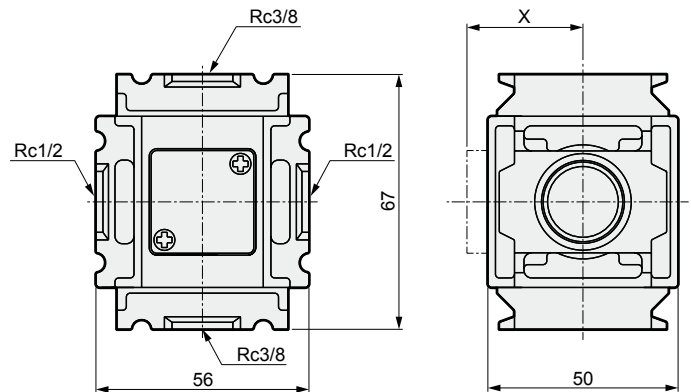

Option dimensions

Option	X
T6	30.5
T8	30.5
G401	30.5
R1	45

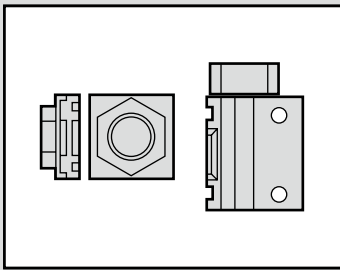

Piping adaptor, L type piping adaptor Standard white series

A100·A400-UN-W Series A101·A401-UN-W Series

Port size: Rc1/4 to Rc3/4, Rc1/4 to Rc1/2



Dimensions and applications

* Model no. for custom order only. Can not be purchased individually.

Pipe adaptor

● Applications

- Model no.: A100-UN-6, 8, 10-W
A400-UN-8, 10, 15, 20-W

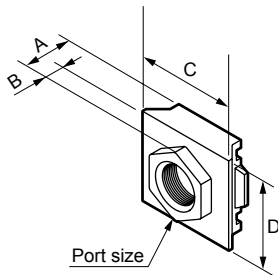

Model no.	Port size	Applicable model	A	B	C	D	Other
A100-UN-6-W	1/8	1000 Series	21.5	13.5	40	36	-
A100-UN-8-W	1/4						
A100-UN-10-W	3/8						
A400-UN-8-W	Rc1/4	2000,	20	6	50	45	Number with the parenthesis is Rc3/4
A400-UN-10-W	Rc3/8	3000, 4000					
A400-UN-15-W	Rc1/2	Series					
A400-UN-20-W	Rc3/4	Series					

L type piping adapter

How to order

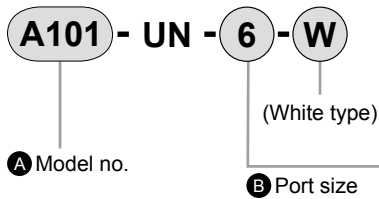

Symbol	Descriptions		
A Model no.			
A101	L type piping adapter		
A401	L type piping adapter		
B Port size			
		A101	A401
6	1/8	●	
8	1/4	●	●
10	3/8		●
15	1/2		●

· Applicable models: · A101-UN-6, 8-W ... 1000-W Series
· A401-UN-8, 10, 15-W ... 2000, 3000, 4000-W Series

Dimensions

● A101-UN

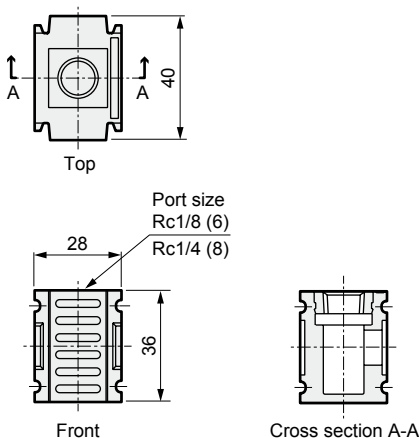

● A401-UN

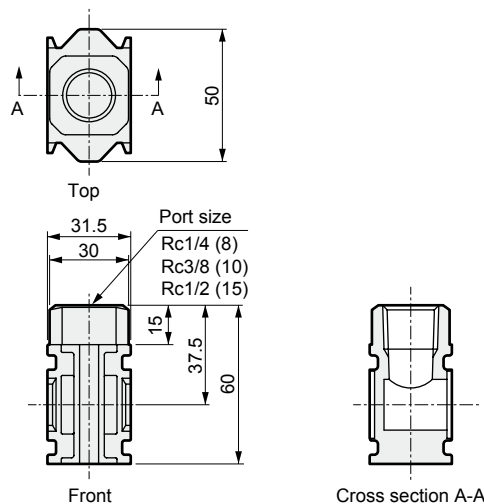

Applications



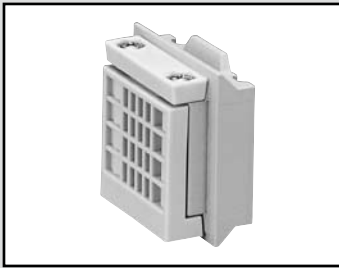

Masking adapter

CXU10-MA-UN CXU30-MA-UN Series

Used for masking on the fitting section.

CXU10-MA

Face to face
10.5mm

CXU30-MA

Face to face
21.5mm

Custom
order only

How to order

CXU10-MA-UN-00
CXU30-MA-UN-00

* Model no. for custom order only.
Can not be purchased individually.

Internal structure and parts list

● CXU10-MA-UN-00

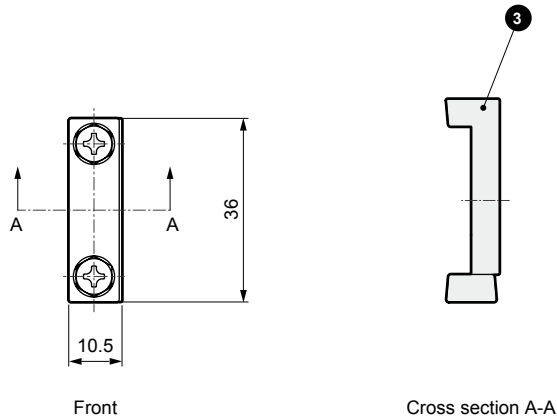

● CXU30-MA-UN-00

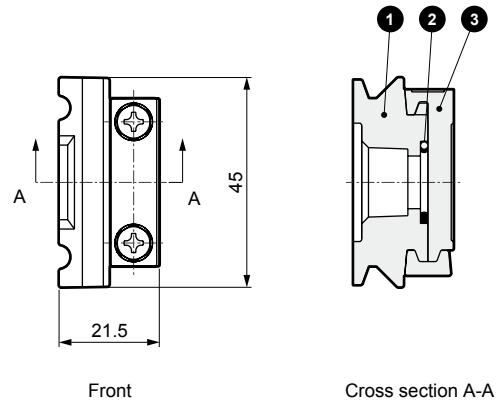

No.	Part name	Model no.
1	Module transform adaptor	CXU13-CA-00
2	O-ring	JASO-2013
3	Masking adapter	CXU10-MA-00

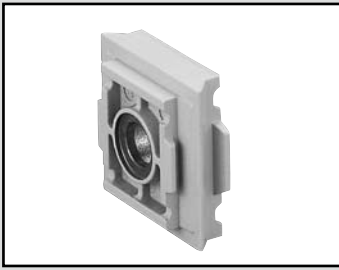

Module transform adaptor

CXU13-CA-UN Series

Connectable with 1000, 2000, 3000, 4000 Series



How to order

CXU13-CA - UN - 00

* Model no. for custom order only.
Can not be purchased individually.
Refer to page 40 for the model no. of your order.

Dimensions

● CXU13-CA-UN-00

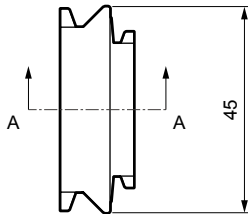

Top

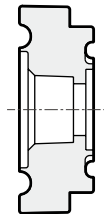

Cross section A-A

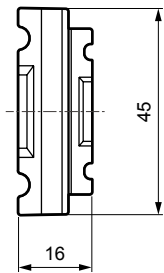

Front

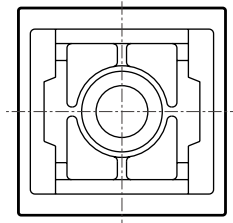

Side

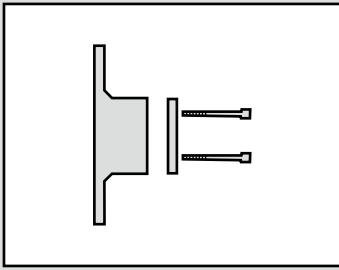

Bracket, joiner

B-UN-W, J-UN-W Series

Custom order only

Dimensions and applications

* Model no. for custom order only. Can not be purchased individually. Refer to page 41 for the model no. of your order.

T type bracket set

● Model no.: B110-UN-W·B310-UN-W·B410-UN-W

● Applications

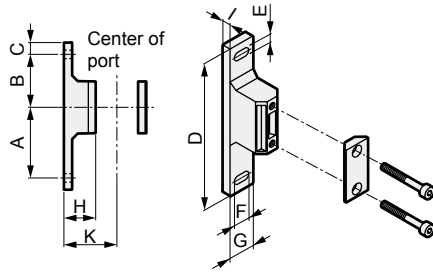

Note 1: B310-UN-W and B410-UN-W cannot be combined.
Note 2: By using B110-UN-W, 1000 Series can be adjusted to the same height as 3000 Series.

Model no.	Applicable model	A	B	C	D	E	F	G	H	I	K
B110-UN-W	1000 Series	45	35	10	100	5.5	2	16	25	7	40
B110-UN-H-W	1000 Series	45	35	10	100	5.5	2	16	30	7	45
B310-UN-W	2000 Series	60	45	10	125	7	7	22	27	7	45
	3000 Series										
B410-UN-W	4000 Series	60	45	10	125	7	7	22	37	7	55

Fitting set

● Model no.: C1000-J100-UN-W
C4000-J400-UN-W

● Applications

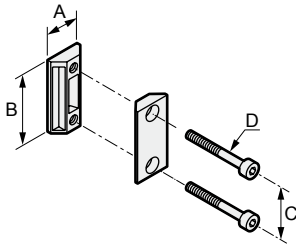

Model no.	Applicable model	A	B	C	D
C1000-J100-UN-W	1000 Series	10	36	26	M3.5
C4000-J400-UN-W	2000 Series	21	44	32	M5
	3000 Series				
	4000 Series				

Order made air units

Overview

All air unit combinations are available as customized combinations from CKD.

Module connections in the vertical direction which is not available with customized units, are now available.

Features

- ① **Horizontal or vertical**
Vertical and horizontal pipes can be arranged versatility. Solenoid valves can also be connected freely.
- ② **Unlimited flexibility**
Module components not listed in this catalog are also available.
- ③ **Reduce man-hours**
All components are connected as modules, eliminating work such as piping.

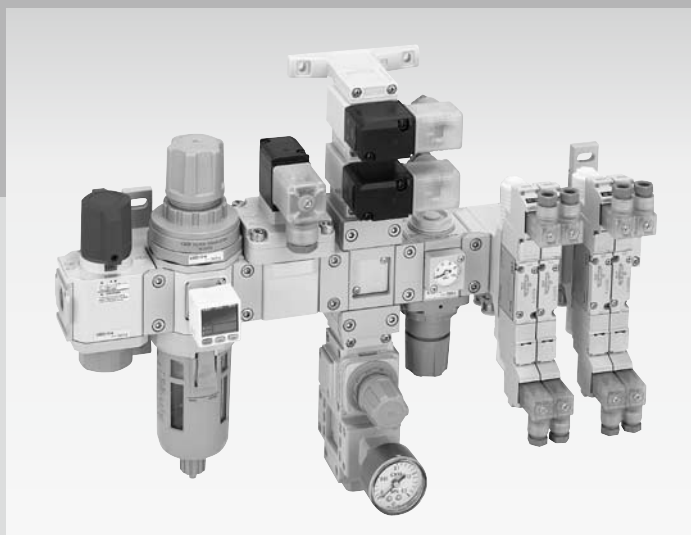

CONTENTS

- Order made air units
CXUZ Series

90

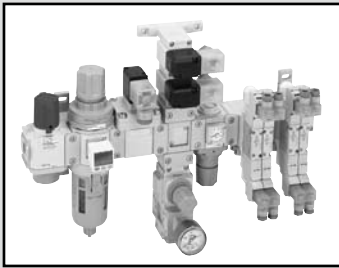

Order made air units

CXUZ Series

How to order





CXUZ-FL







Dedicated model no.
Each product is assigned a 6-digit number.

Air unit components can be combined depending on applications and space.
Contact your sales office for combinations.

Related products (compatible modular combination products)

CXU10 (applicable model: 1000 Series)					
Model	Shut-off valve	Precision regulator	Electro-pneumatic regulator	Reed switch type Compact mechanical pressure switch	High performance oil mist filter
Model no.	V1000-W 	RP1000 	EVD-1000 	P1100-W 	MX1000-W 
Catalog No.	CC-962	CB-024S	CB-024S	CC-962	CB-024S

CXU30 (applicable model: 3000, 4000 Series)					
Model	Slow start valve	Precision regulator	Electro-pneumatic regulator	Reed switch type Compact mechanical pressure switch	High performance oil mist filter
Model no.	V3301-W V3321-W 	RP2000 	EVD-3000 	P4100-W 	MX3000-W MX4000-W 
Catalog No.	CC-962	CB-024S	CB-024S	CC-962	CB-024S

MEMO

- CKD (SHANGHAI) CORPORATION
- WUXI OFFICE
 - BEIJING OFFICE
 - CHENGDU OFFICE
 - NANJING OFFICE
 - TIANJIN OFFICE
 - GUANGZHOU OFFICE
 - HANGZHOU OFFICE
 - CHANGCHUN OFFICE
 - SHENZHEN OFFICE
 - WUHAN OFFICE
 - DALIAN OFFICE
 - DONGGUAN OFFICE
 - QINGDAO OFFICE
 - XIAN OFFICE
 - SUZHOU OFFICE
 - CHONGQING OFFICE

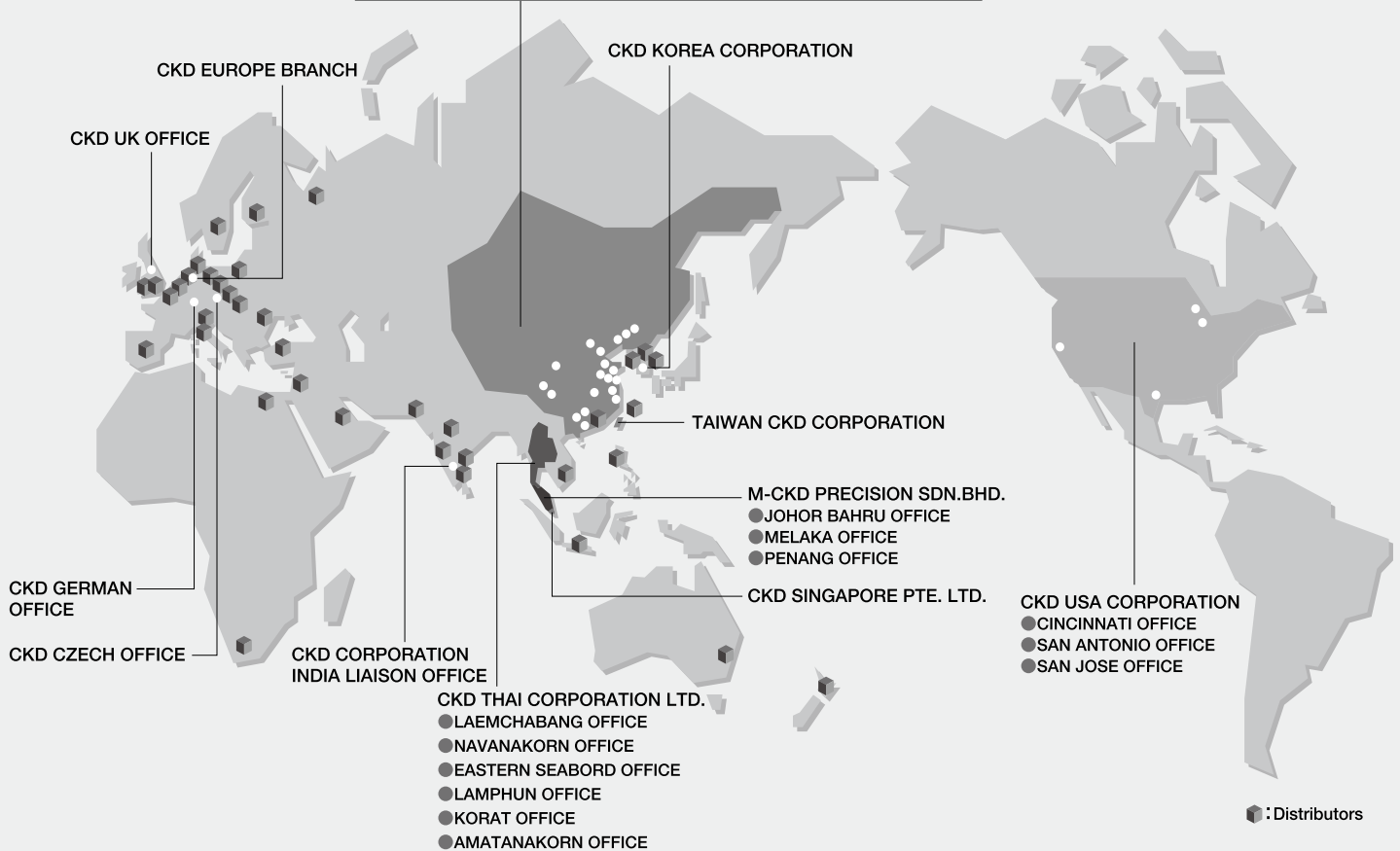

CKD Corporation

Website <http://www.ckd.co.jp/>

- OVERSEAS SALES ADMINISTRATION DPT.
OVERSEAS BUSINESS DIV. 2-250 Uji Komaki, Aichi 485-8551, Japan
- PHONE +81-(0)568-74-1338 FAX +81-(0)568-77-3461

U.S.A.

CKD USA CORPORATION

- HEADQUARTERS
4080 Winnetka Avenue, Rolling Meadows, IL 60008 USA
PHONE +1-847-368-0539 FAX +1-847-788-0575

EUROPE

CKD EUROPE BRANCH

De Fruittuinen 28 Hoofddorp 2132NZ The Netherlands
PHONE +31-(0)23-5541490 FAX +31-(0)23-5541491

Malaysia

M-CKD PRECISION SDN.BHD.

- HEADQUARTERS
Lot No.6,Jalan Modal 23/2, Seksyen 23, Kawasan, MIEL,
Fasa 8, 40300 Shah Alam,Selangor Darul Ehsan, Malaysia
PHONE +60-(0)3-5541-1468 FAX +60-(0)3-5541-1533

Thailand

CKD THAI CORPORATION LTD.

- SALES HEADQUARTERS-BANGKOK OFFICE
Suwan Tower, 14/1 Soi Saladaeng 1, North Sathorn Rd., Bangrak,
Bangkok 10500 Thailand
PHONE +66-(0)2-267-6300 FAX +66-(0)2-267-6305

Singapore

CKD SINGAPORE PTE LTD.

705 Sims Drive #03-01/02, Shun Li Industrial Complex,
387384 Singapore
PHONE +65-6744-2623 FAX +65-6744-2486

Taiwan

TAIWAN CKD CORPORATION

16F-3, No.109, Sec.1 Jhongshan Rd., Shinjhuang City, Taipei County
242, Taiwan(R.O.C)
PHONE +886-(0)2-8522-8198 FAX +886-(0)2-8522-8128

China

CKD (SHANGHAI) CORPORATION

- SALES HEADQUARTERS / SHANGHAI OFFICE
Room 601, Yuan Zhong Scientific Research Building,
1905 Hongmei Road,Shanghai, 200233, China
PHONE +86-(0)21-61911888 FAX +86-(0)21-60905356

Korea

CKD KOREA CORPORATION

3rd FL, Sam Young B/D, 371-20
Sinsu-Dong, Mapo-Gu, Seoul, 121-110, Korea
PHONE +82-(0)2-783-5201~5203 FAX +82-(0)2-783-5204

The goods and their replicas, or the technology and software in this catalog are subject to complementary export regulations by Foreign Exchange and Foreign Trade Law of Japan.
If the goods and their replicas, or the technology and software in this catalog are to be exported, laws require the exporter to make sure they will never be used for the development or the manufacture of weapons for mass destruction.