

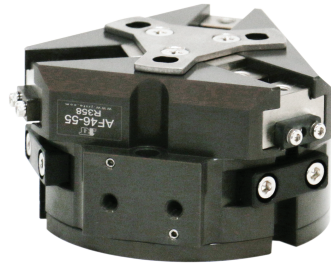

## 특징 (Character)

- 테이퍼 슬라이딩 방식에 의한 견고한 면압구동방식  
Surface pressure driving type by taper sliding
- AIR PORT의 분기구조로 선택사용이 가능하며 밑면 AIR PORT(BP)사용시 SSU 등에 적절한 조합이 가능  
Possible to use by Air port's branch structure and when using underside Airport(BP) possible to combine at SSU, etc
- 개폐 검출용 근접스위치 부착 가능합니다.  
Proximity sensor is available for open-close sensing
- 원형 몸체 구조로 대상물의 중심기준 작업에 효과적  
Easy to grip the center of workpiece by the cylindrical structure



## 웨이 방식 (Wedge type)

### 작동 방식 (Kinetics)

큰힘의 중심 파지를 위한 웨지방식  
wedge system for high level of power transmission and centric gripping

### 조 (Jaws)

파지부  
for gripping

### 조절형 도그 (Adjustable Dog)

근접 센서 감지용  
for proximity sensor detection

### 몸체 (Body)

경질 처리된 경량의 알루미늄 합금  
high-tensile aluminum body with lightest possible because of hard anodizing

### 센서 브라켓 (Sensor bracket)

근접 센서 부착용  
brackets for proximity switch and adjustable control cams integrated into the housing

### 슬라이드웨이 (Slideway)

중량물 파지시 유격을 최소화하기 위한 정밀 가공  
extremely precise for gripping with small clearance under heavy loads

### 구동부 (Drive)

복동식  
double acting pneumatic cylinder

### 중심 취부 (Centering and mounting options)

다용도의 손쉬운 취부 방식  
gripping has universal mount

## 부품분해도 (Exploded view)

※ 본 분해도는 한 제품을 예시하였으므로 기종별로 차이가 있을 수 있습니다.  
 ※ This is exploded view illustrates a certain product only. The contents may vary by product models.

AF101
AF02
AF04P
AF105P
AF10
AF13
AF14
AF15
AF316
AF316L
AF416
AF17
AF117
AF24
AF26
AF28D
AF28DS
AF30
AF30L
<b>AF46</b>
AF56L
RAF56N
MF16
JPGb
JEGG
JEGb
JEGC
JEGD
JVGE

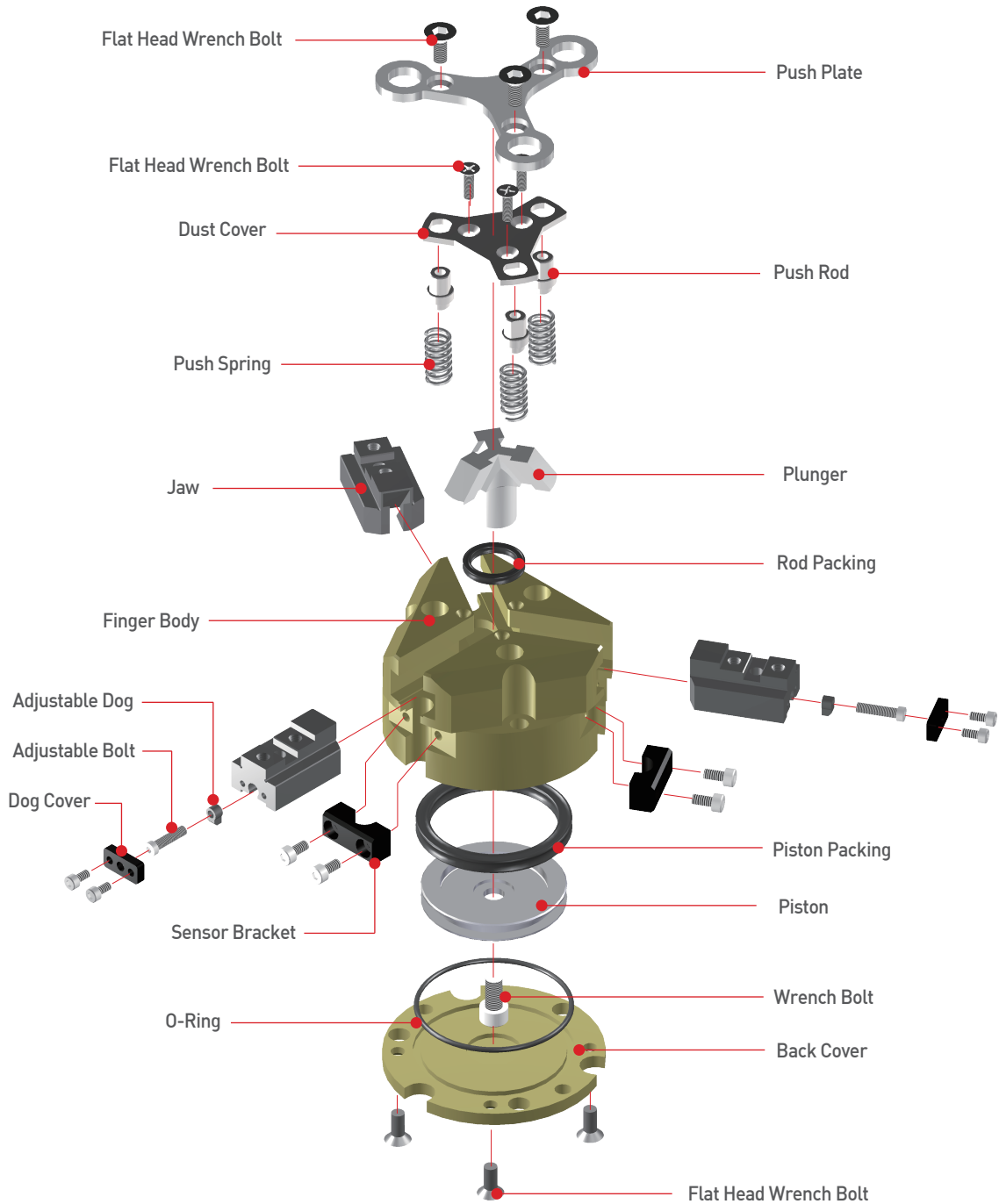

주문기호 ( How to Order )

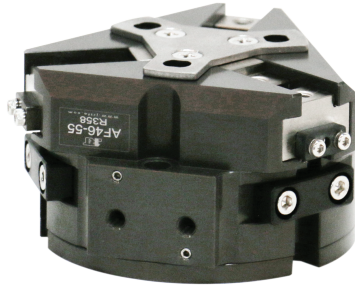

※ 옵션 사항이 적용되지 않는 제품이 있으니, 주문시 확인 바랍니다. (치수도 참조.)

※ There are products that do not apply to options, so please check when ordering. [Refer to dimensions.]



▣ 제품사양 ( Specification )

P=공기압력(bar), L=작용점까지의 거리(mm)  
P = Air Pressure(bar), L = Gripping point distance(mm)

제품명칭 Products Name	AF46A-30			AF46A-40			AF46A-55			단위 Unit
	Standard	AF46SNA-30	AF46SSA-30	Standard	AF46SNA-40	AF46SSA-40	Standard	AF46SNA-55	AF46SSA-55	
개폐범위 Stroke	8	10	4	12	15	6	16	20	8	mm
제품중량 Weight	0.24			0.43			0.75			kg
최대치구길이 Max. length attach	50			60			80			mm
배관접속구 Fitting size	M5			M5			M5			
파지력 : 열림시 Gripping force : Open	60.82P 1+0.01L	51.04P 1+0.01L	109.45P 1+0.01L	109.87P 1+0.008L	92.20P 1+0.008L	197.71P 1+0.008L	241.33P 1+0.01L	202.51P 1+0.01L	434.28P 1+0.01L	N
파지력 : 닫힘시 Gripping force : Close	52.97P 1+0.01L	44.45P 1+0.01L	95.32P 1+0.01L	98.1P 1+0.008L	82.32P 1+0.008L	176.53P 1+0.008L	233.48P 1+0.01L	195.92P 1+0.01L	420.15P 1+0.01L	N
1사이클당 공기소모량 Air consumption per cycle	6.8			19.9			46.0			cm <sup>3</sup>
닫힘시/열림시 시간 Closing / Opening time	0.03/0.03			0.04/0.04			0.06/0.05			sec
반복정밀도 Repeat accuracy	0.01			0.01			0.01			mm
연속사용회수 Continuation usage amount	60			50			50			cpm
사용압력 Operating pressure				3~7						bar
주위온도 Ambient temperature				-5 to 60						℃
윤활 Lubrication				불필요 Needless						

제품명칭 Products Name	AF46A-75			AF46A-95			AF46A-125			단위 Unit
	Standard	AF46SNA-75	AF46SSA-75	Standard	AF46SNA-95	AF46SSA-95	Standard	AF46SNA-125	AF46SSA-125	
개폐범위 Stroke	20	24	10	26	31	12	32	39	16	mm
제품중량 Weight	1.30			2.05			4.07			kg
최대치구길이 Max. length attach	100			120			160			mm
배관접속구 Fitting size	PF(G) 1/8			PF(G) 1/8			PF(G) 1/8			
파지력 : 열림시 Gripping force : Open	421.83P 1+0.007L	353.97P 1+0.007L	759.10P 1+0.007L	793P 1+0.01L	665.44P 1+0.01L	1427.03P 1+0.01L	1372P 1+0.01L	1151.30P 1+0.01L	2468.96P 1+0.01L	N
파지력 : 닫힘시 Gripping force : Close	403.19P 1+0.007L	338.33P 1+0.007L	725.55P 1+0.007L	750P 1+0.01L	629.35P 1+0.01L	1349.65P 1+0.01L	1303P 1+0.01L	1093.40P 1+0.01L	2344.79P 1+0.01L	N
1사이클당 공기소모량 Air consumption per cycle	103.6			213.8			466.6			cm <sup>3</sup>
닫힘시/열림시 시간 Closing / Opening time	0.08/0.07			0.17/0.17			0.40/0.40			sec
반복정밀도 Repeat accuracy	0.01			0.02			0.05			mm
연속사용회수 Continuation usage amount	40			40			30			cpm
사용압력 Operating pressure				3~7						bar
주위온도 Ambient temperature				-5 to 60						℃
윤활 Lubrication				불필요 Needless						

반복정밀도 : 연속 100회 작동후 측정치  
After 100 consecutive strokes to end positions

- AF101
- AF02
- AF04P
- AF105P
- AF10
- AF13
- AF14
- AF15
- AF316
- AF316L
- AF416
- AF17
- AF117
- AF24
- AF26
- AF28D
- AF28DS
- AF30
- AF30L
- AF46**
- AF56L
- RAF56N
- MF16
- JPGB
- JEGG
- JEGB
- JEGC
- JEGD
- JVGE



▣ 제품사양 ( Specification )

P=공기압력(bar), L=작용점까지의 거리(mm)  
 P = Air Pressure(bar), L = Gripping point distance(mm)

제품명칭 Products Name	AF46A-160			AF46-220	단위 Unit
	Standard	AF46SNA-160	AF46SSA-160	Standard	
개폐범위 Stroke	50	58	20	60	mm
제품중량 Weight	10.85			22.96	kg
최대치구길이 Max. length attach	200			250	mm
배관접속구 Fitting size	PF(G) 1/8			PF(G) 1/4	
파지력 : 열림시 Gripping force : Open	$\frac{2248P}{1+0.01L}$	$\frac{1886.38P}{1+0.01L}$	$\frac{5182.64P}{1+0.01L}$	$\frac{4250P}{1+0.01L}$	N
파지력 : 닫힘시 Gripping force : Close	$\frac{2158P}{1+0.01L}$	$\frac{1810.86P}{1+0.01L}$	$\frac{4975.15P}{1+0.01L}$	$\frac{4072P}{1+0.01L}$	N
1사이클당 공기소모량 Air consumption per cycle	1182.2			2233	cm <sup>3</sup>
닫힘시/열림시 시간 Closing / Opening time	1.1/1.1			1.2/1.2	sec
반복정밀도 Repeat accuracy	0.1			0.1	mm
연속사용회수 Continuation usage amount	20			20	cpm
사용압력 Operating pressure	3~7				bar
주위온도 Ambient temperature	-5 to 60				℃
윤활 Lubrication	불필요 Needless				

반복정밀도 : 연속 100회 작동후 측정치  
 After 100 consecutive strokes to end positions

- AF101
- AF02
- AF04P
- AF105P
- AF10
- AF13
- AF14
- AF15
- AF316
- AF316L
- AF416
- AF17
- AF117
- AF24
- AF26
- AF28D
- AF28DS
- AF30
- AF30L
- AF46**
- AF56L
- RAF56N
- MF16
- JPGB
- JEGG
- JEGB
- JEGC
- JEGD
- JVGE

## 작용점에서의 파지력 (Gripping Force From a Point of Action)

범례(Legend) : — 7[bar] — 5[bar] — 3[bar]

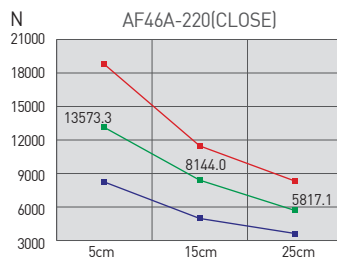
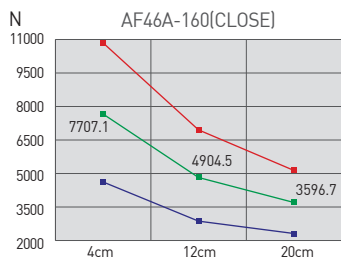
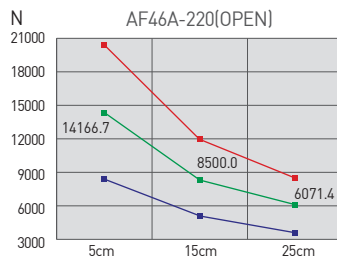
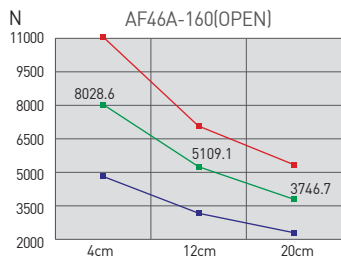
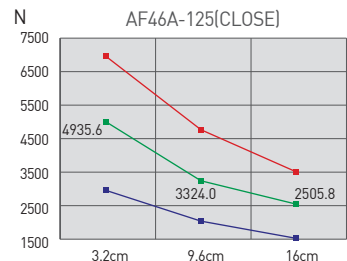
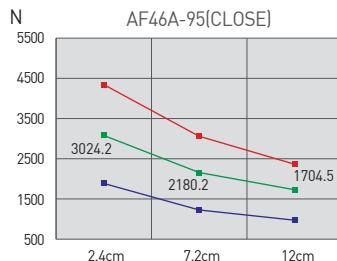
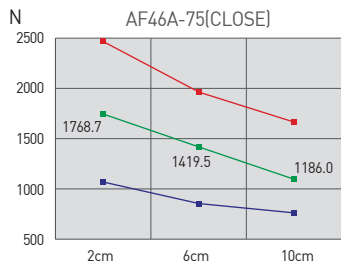
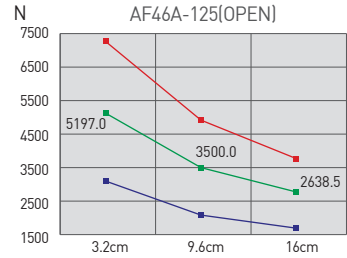
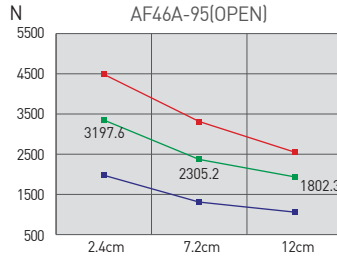
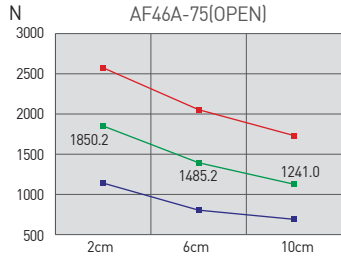
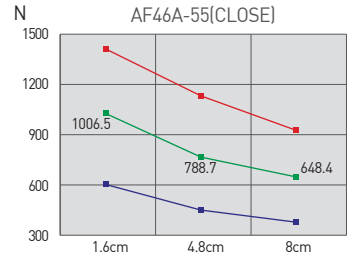
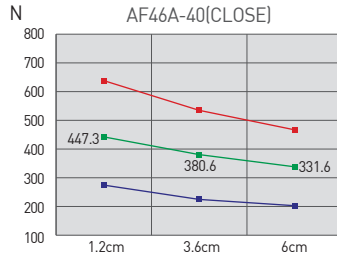
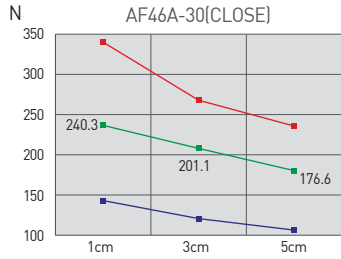
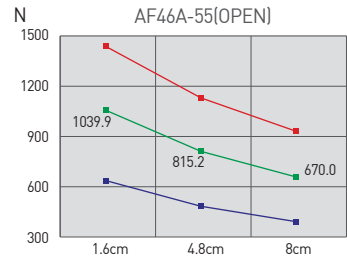
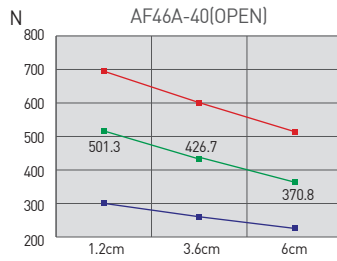
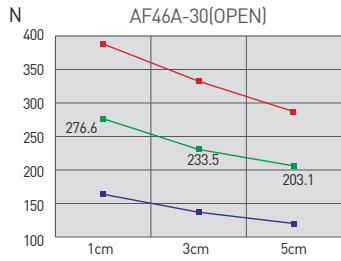

**AF46A-30**

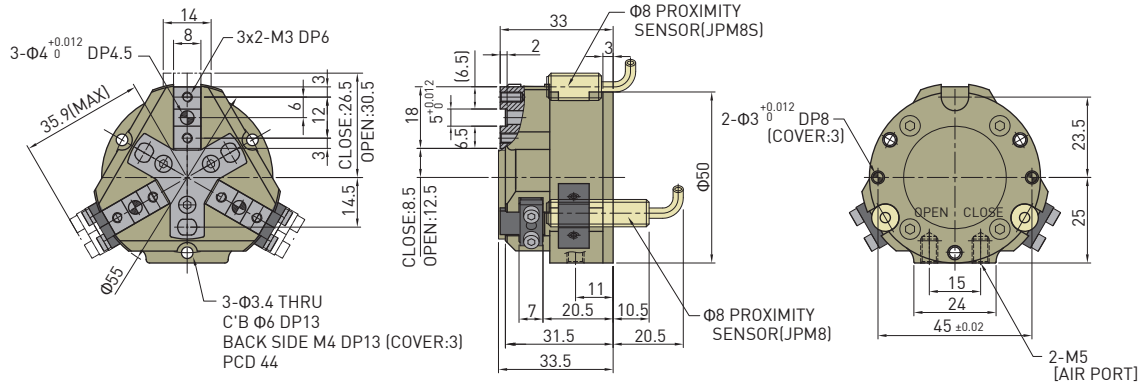

■ BP (Bottom Port) DIMENSION

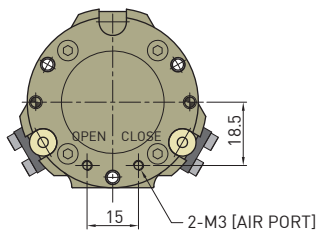

■ CP (Standard Center Push) DIMENSION

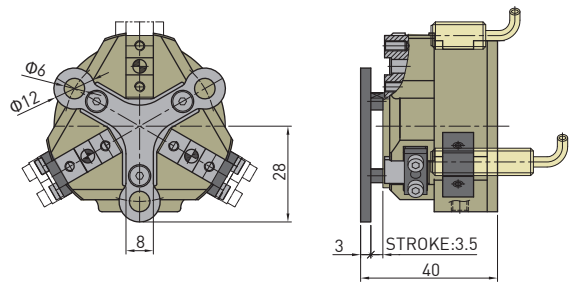

■ AF46SNA-30 DIMENSION

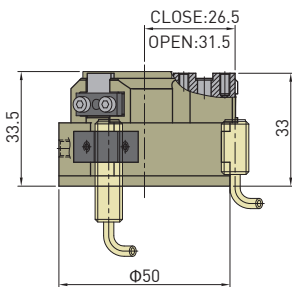

■ AF46□□A-30...-NO(NC) DIMENSION

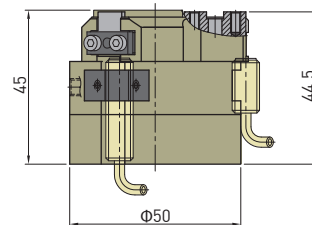

■ AF46SSA-30 DIMENSION

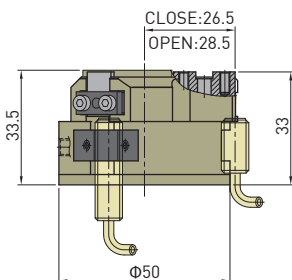

- AF101
- AF02
- AF04P
- AF105P
- AF10
- AF13
- AF14
- AF15
- AF316
- AF316L
- AF416
- AF17
- AF117
- AF24
- AF26
- AF28D
- AF28DS
- AF30
- AF30L
- AF46**
- AF56L
- RAF56N
- MF16
- JPGb
- JEGG
- JEGb
- JEGC
- JEGD
- JVGE

## AF46A-40

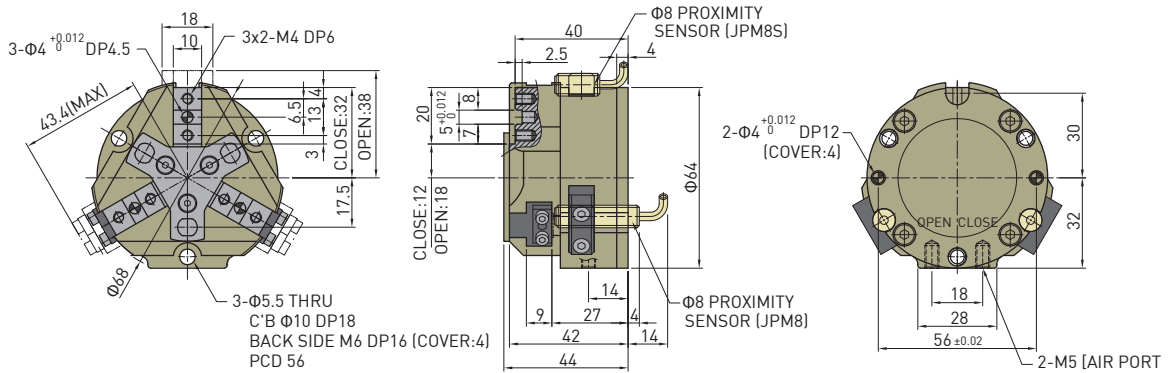

### BP (Bottom Port) DIMENSION

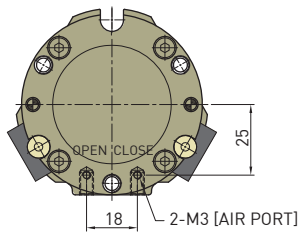

### CP (Standard Center Push) DIMENSION

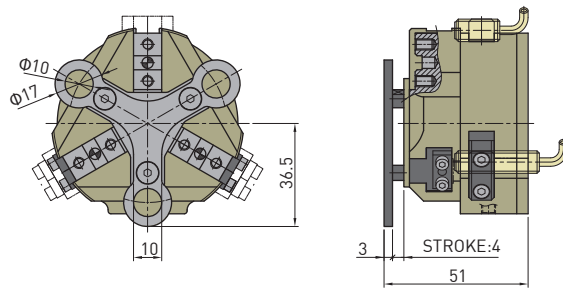

### AF46SNA-40 DIMENSION

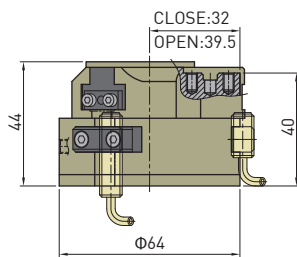

### AF46□□A-40...-NO(NC) DIMENSION

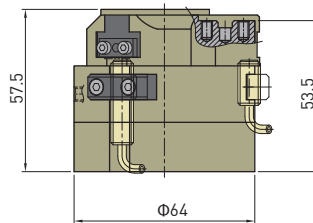

### AF46SSA-40 DIMENSION

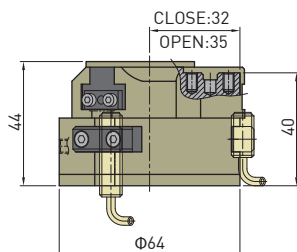

AF46A-55

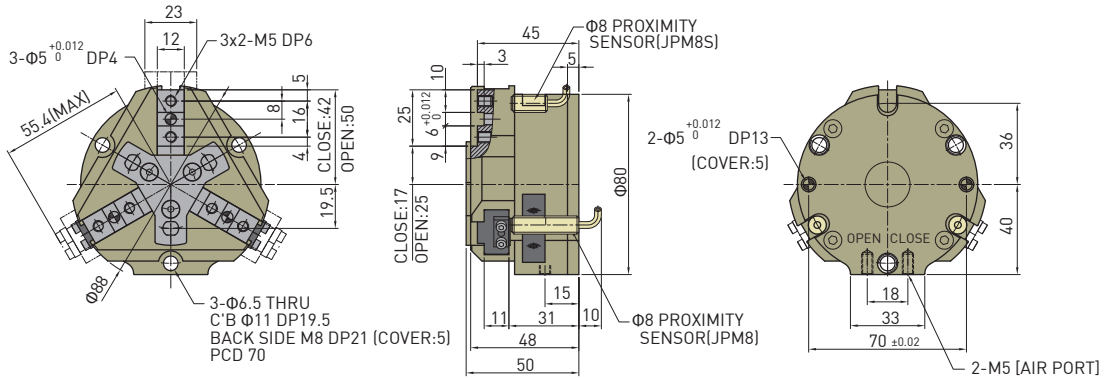

■ BP (Bottom Port) DIMENSION

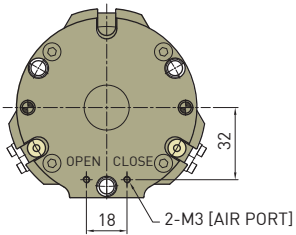

■ CP (Standard Center Push) DIMENSION

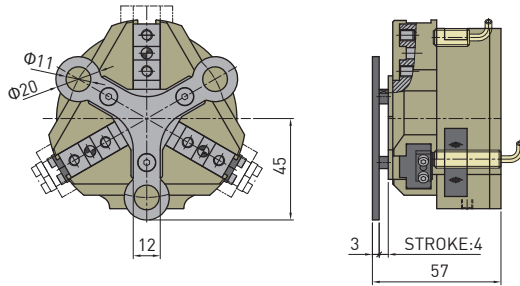

■ AF46SNA-55 DIMENSION

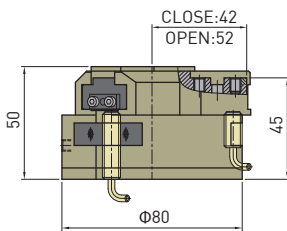

■ AF46□□A-55...-NO(NC) DIMENSION

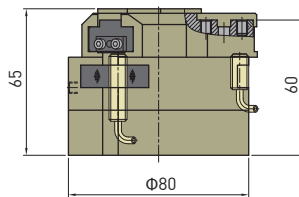

■ AF46SSA-55 DIMENSION

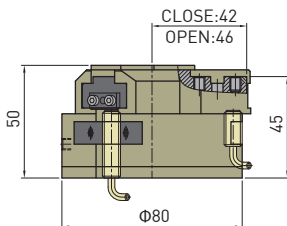

- AF101
- AF02
- AF04P
- AF105P
- AF10
- AF13
- AF14
- AF15
- AF316
- AF316L
- AF416
- AF17
- AF117
- AF24
- AF26
- AF28D
- AF28DS
- AF30
- AF30L
- AF46**
- AF56L
- RAF56N
- MF16
- JPGB
- JEGG
- JEGB
- JEGC
- JEGD
- JVGE

AF46A-75

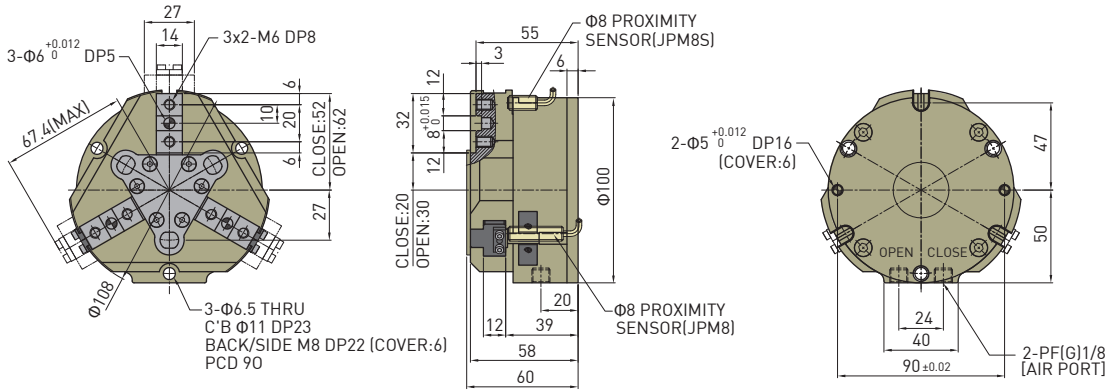

■ BP (Bottom Port) DIMENSION

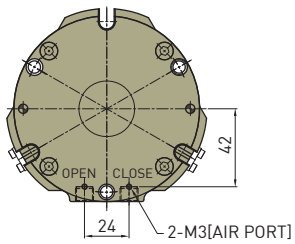

■ CP (Standard Center Push) DIMENSION

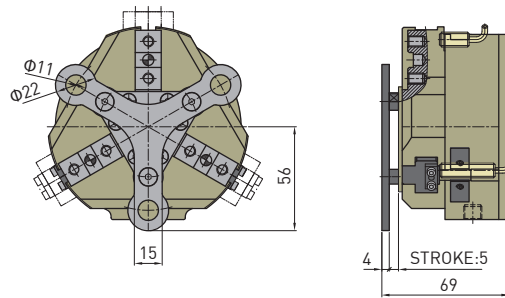

■ AF46SNA-75 DIMENSION

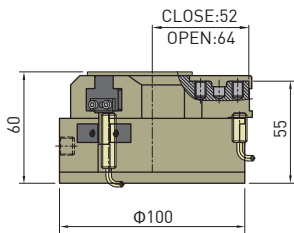

■ AF46□□A-75...-NO(NC) DIMENSION

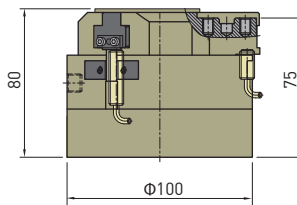

■ AF46SSA-75 DIMENSION

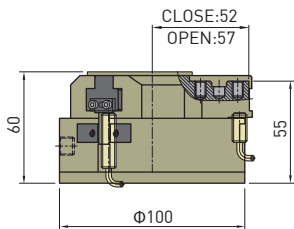

AF46A-95

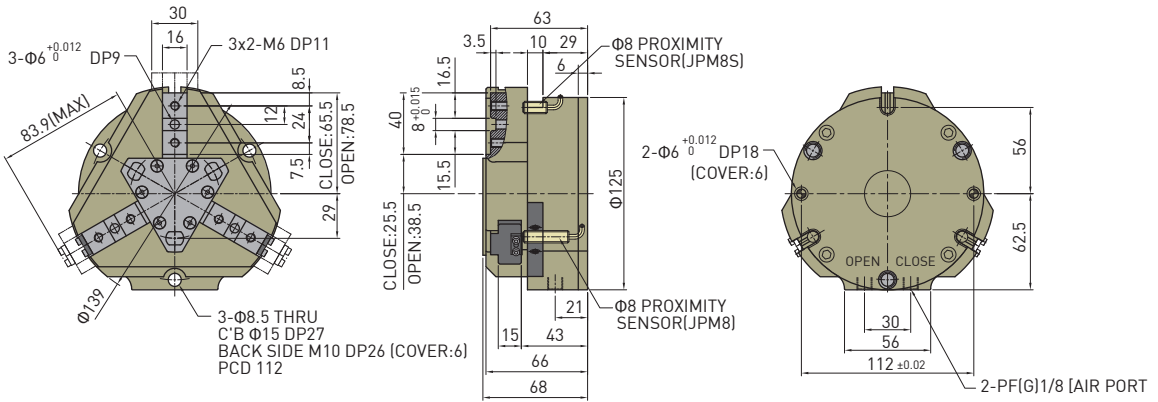

■ BP (Bottom Port) DIMENSION

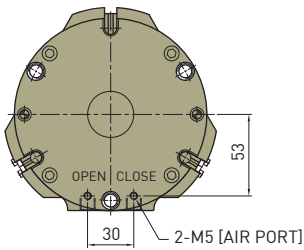

■ CP (Standard Center Push) DIMENSION

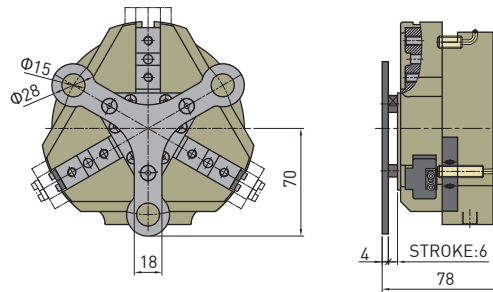

■ AF46SNA-95 DIMENSION

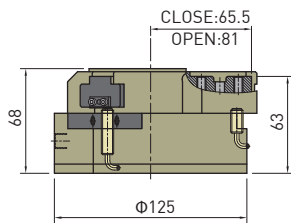

■ AF46□□A-95...-NO(NC) DIMENSION

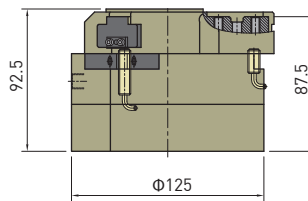

■ AF46SSA-95 DIMENSION

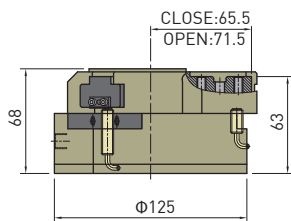

- AF101
- AF02
- AF04P
- AF105P
- AF10
- AF13
- AF14
- AF15
- AF316
- AF316L
- AF416
- AF17
- AF117
- AF24
- AF26
- AF28D
- AF28DS
- AF30
- AF30L
- AF46**
- AF56L
- RAF56N
- MF16
- JPGB
- JEGG
- JEGB
- JEGC
- JEGD
- JVGE

AF46A-125

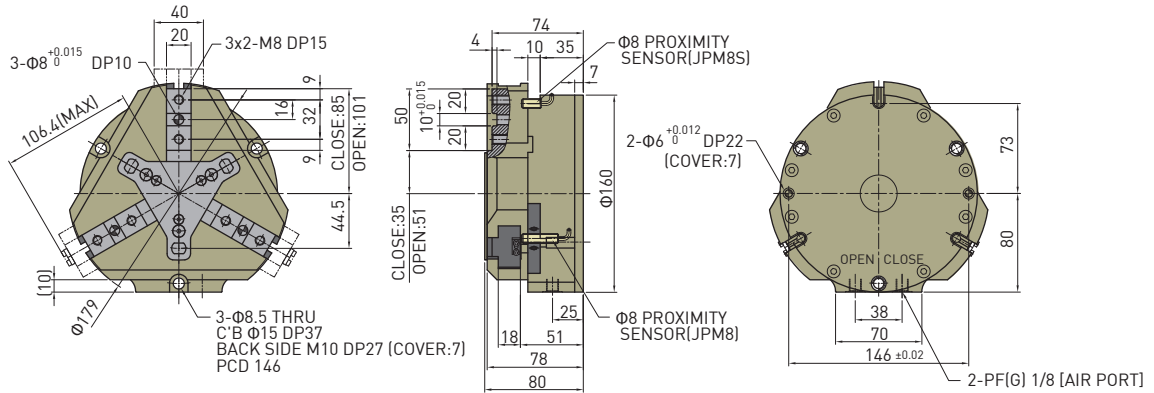

■ BP [Bottom Port] DIMENSION

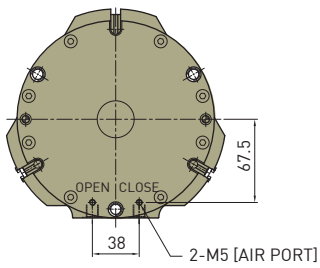

■ CP [Standard Center Push] DIMENSION

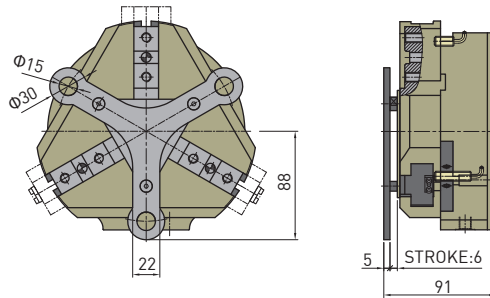

■ AF46SNA-125 DIMENSION

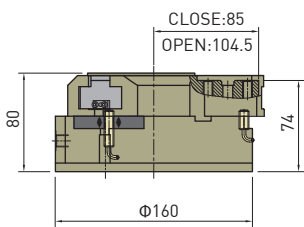

■ AF46□□A-125...-NO(NC) DIMENSION

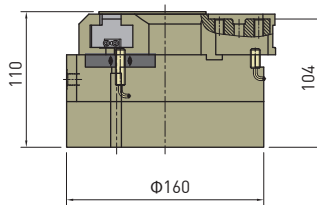

■ AF46SSA-125 DIMENSION

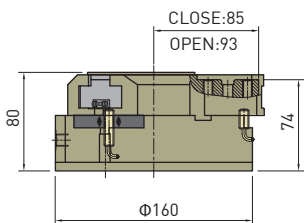



AF46A-160

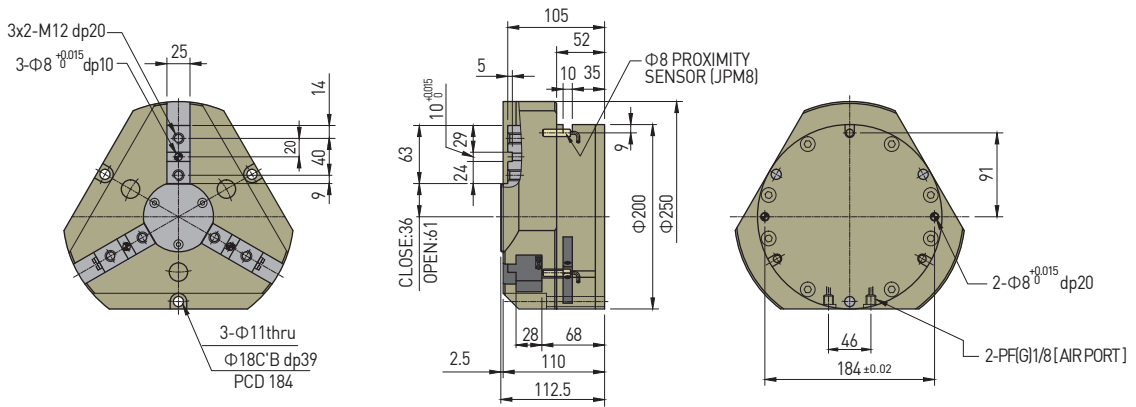

■ BP (Bottom Port) DIMENSION

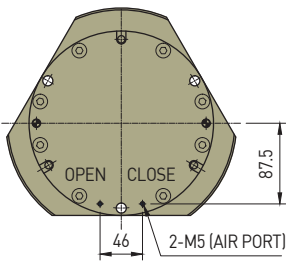

■ CP STANDARD OPTION DIMENSION

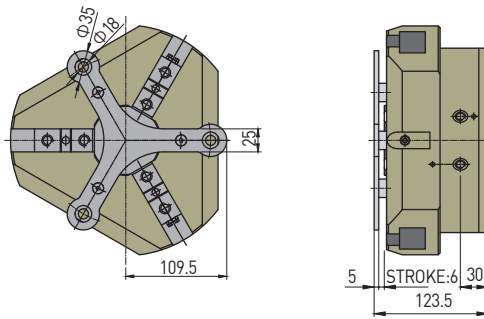

■ AF46SNA-160 DIMENSION

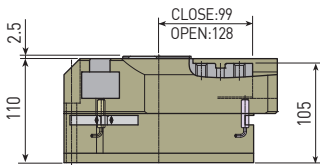

■ AF46SSA-160 DIMENSION

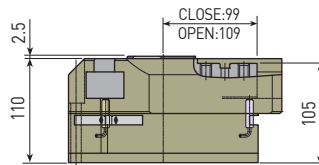

AF46-220

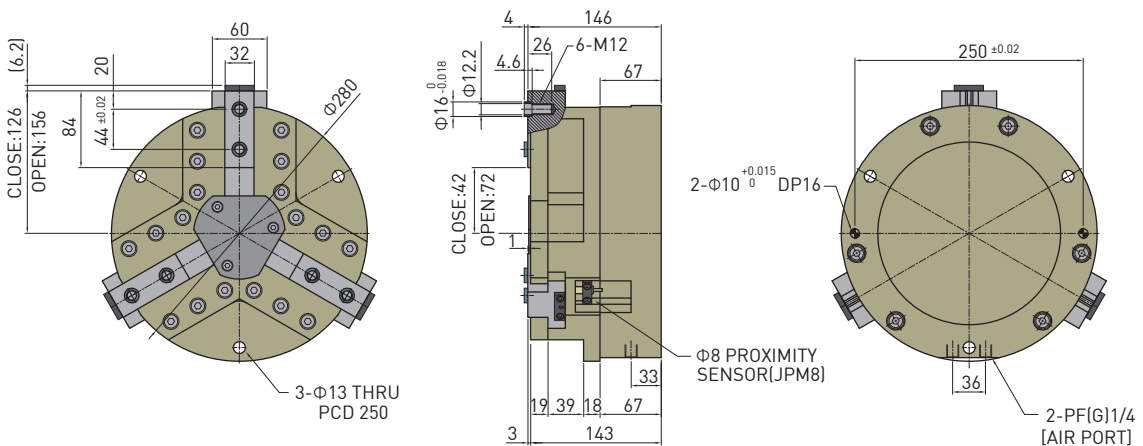

AF101
AF02
AF04P
AF105P
AF10
AF13
AF14
AF15
AF316
AF316L
AF416
AF17
AF117
AF24
AF26
AF28D
AF28DS
AF30
AF30L
<b>AF46</b>
AF56L
RAF56N
MF16
JPGb
JEGG
JEGb
JEGC
JEGD
JVGE