

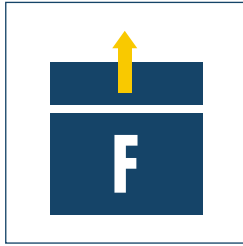

Sizes
061 .. 221

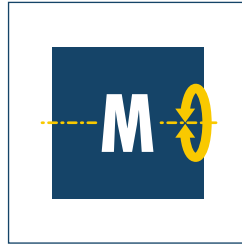

Triggering force F_z
1713 N .. 13800 N



Triggering torque M_x
59 Nm .. 1300 Nm



Triggering torque M_y
59 Nm .. 1300 Nm



Triggering torque M_z
61 Nm .. 960 Nm

Application example



Triple transfer unit for repacking small cardboard boxes

1 SWG 50 2-Finger Angular Gripper

2 OPR-101 Collision and Overload Protection

Collision and Overload Protection

Collision and overload protection with automatic reset for protecting robots and handling units against damage resulting from collisions or overload conditions

Area of application

Standard solution for all robot applications whereby the robot, the tool or the workpiece are to be protected in the event of a collision

Your advantages and benefits

Automatic reset

for faster production restart after a collision

Triggering force and torque can be adjusted via the operating pressure

for optimum protection of your components

Integrated monitoring

for signal transmission in the event of a collision, whereby the robot can be stopped

Various ISO adapter plates as an option

for easy attachment to most robots without production expense



General information on the series

Working principle

Integrated cylinder piston

Actuation

Pneumatic, with filtered compressed air (10 µm): dry or lubricated

Maintenance

Maintenance-free

Ambient temperature

From 5 °C to 60 °C

Scope of delivery

Coupling with 5 m cable, operating manual, maintenance instructions, manufacturer's declaration

Warranty

24 months

Sectional diagram

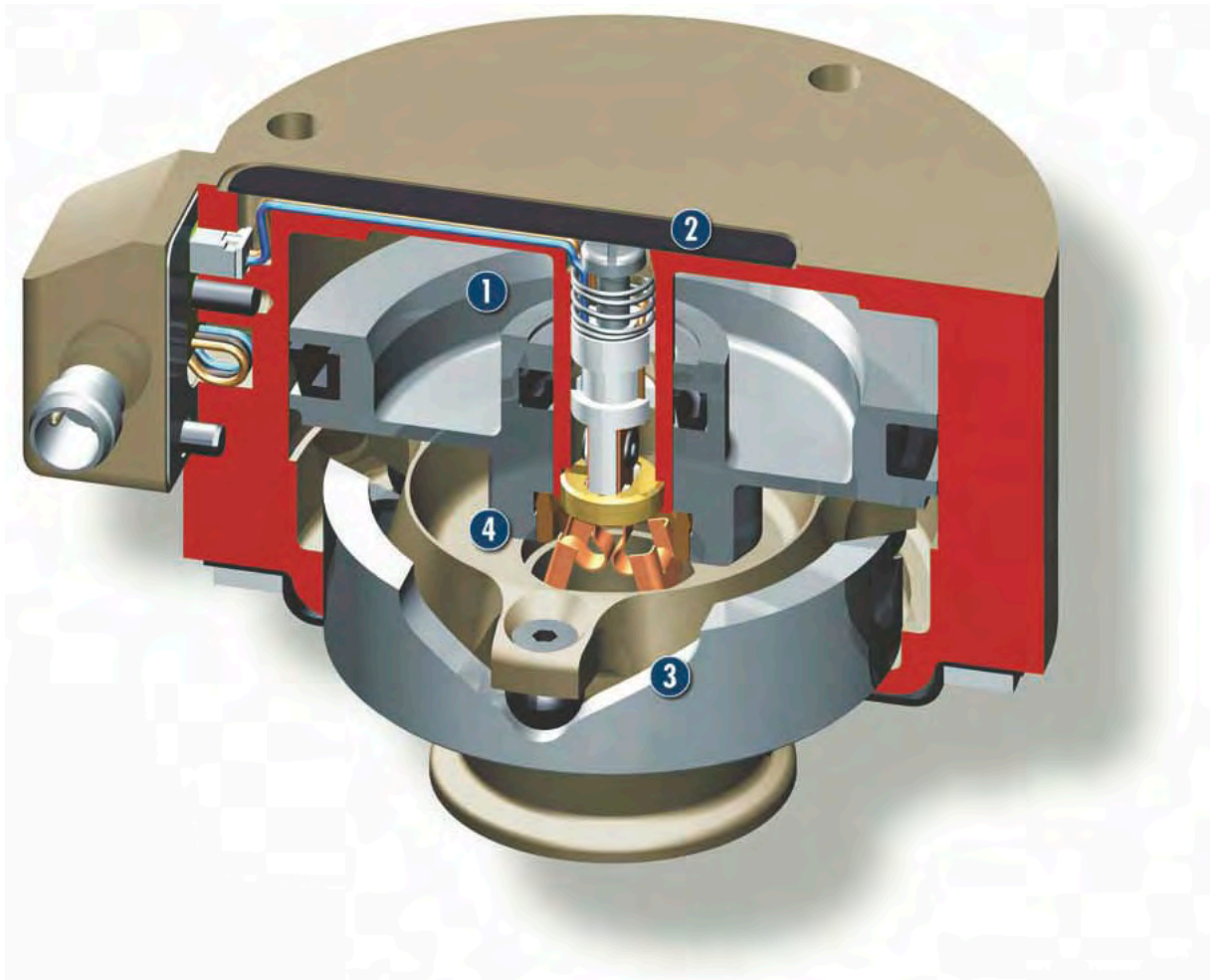

- 1 Drive**
pneumatic for easy adjustment of the triggering force
- 2 Adjustment Screw**
for adjusting the switching point
- 3 Bearing Point**
to absorb strong forces and large moments
- 4 Monitoring**
mechanical and robust

Function description

In the event of a collision, the tool plate deflects while simultaneously actuating the system's emergency stop mechanism. The OPR automatically returns to zero position when the gripper moves away from the collision object. Production can continue immediately as manual resetting is not necessary.

Accessories

Accessories from SCHUNK – the suitable supplement for maximum functionality, reliability and performance of all automation modules.

Adapter plates



Fittings



Cables



① For the exact size of the accessories, the availability for this size and the designation and ID, please refer to the additional views at the end of the size in question. You can find more detailed information on our accessory range in the “Accessories” catalog section.

General information on the series

Extreme ambient conditions

Please note that use in extreme ambient conditions (e.g. in the coolant zone, in the presence of abrasive dust) can significantly reduce the tool life span of these units and we cannot accept any liability for this reduction. However, in many cases we have a solution at hand. Please ask for details.

Forces and moments

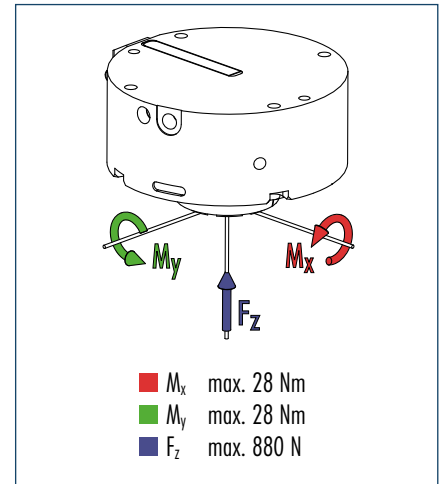

Technical data

Designation		OPR-061-P00	OPR-061-P05	OPR-061-P10	OPR-061-P15
ID without splash protection		321361	321362	321363	321364
ID with splash protection		321365	321366	321367	321368
Axial compensation	[mm]	5.6	5.6	5.6	5.6
Angular compensation	[°]	11	11	11	11
Rotational compensation	[°]	20	20	20	20
Triggering force with maximum operating pressure	[N]	880	880	880	880
Triggering torque with maximum operating pressure	Angular [Nm]	28	28	28	28
	Rotational [Nm]	24.4	24.4	24.4	24.4
Triggering force safeguarded by springs	[N]	-	43	86	128
Triggering torque safeguarded by springs	Angular [Nm]	-	1.4	2.7	4.1
	Rotational [Nm]	-	1.2	2.4	3.6
Maximum operating pressure	[bar]	6.0	5.7	5.4	5.1
Repeat accuracy	[mm]	+/- 0.025	+/- 0.025	+/- 0.025	+/- 0.025
Rotational repeat accuracy	[min]	+/- 5	+/- 5	+/- 5	+/- 5
Sensitivity	[mm]	0.5	0.5	0.5	0.5
Weight	[kg]	0.32	0.35	0.35	0.35

Main views

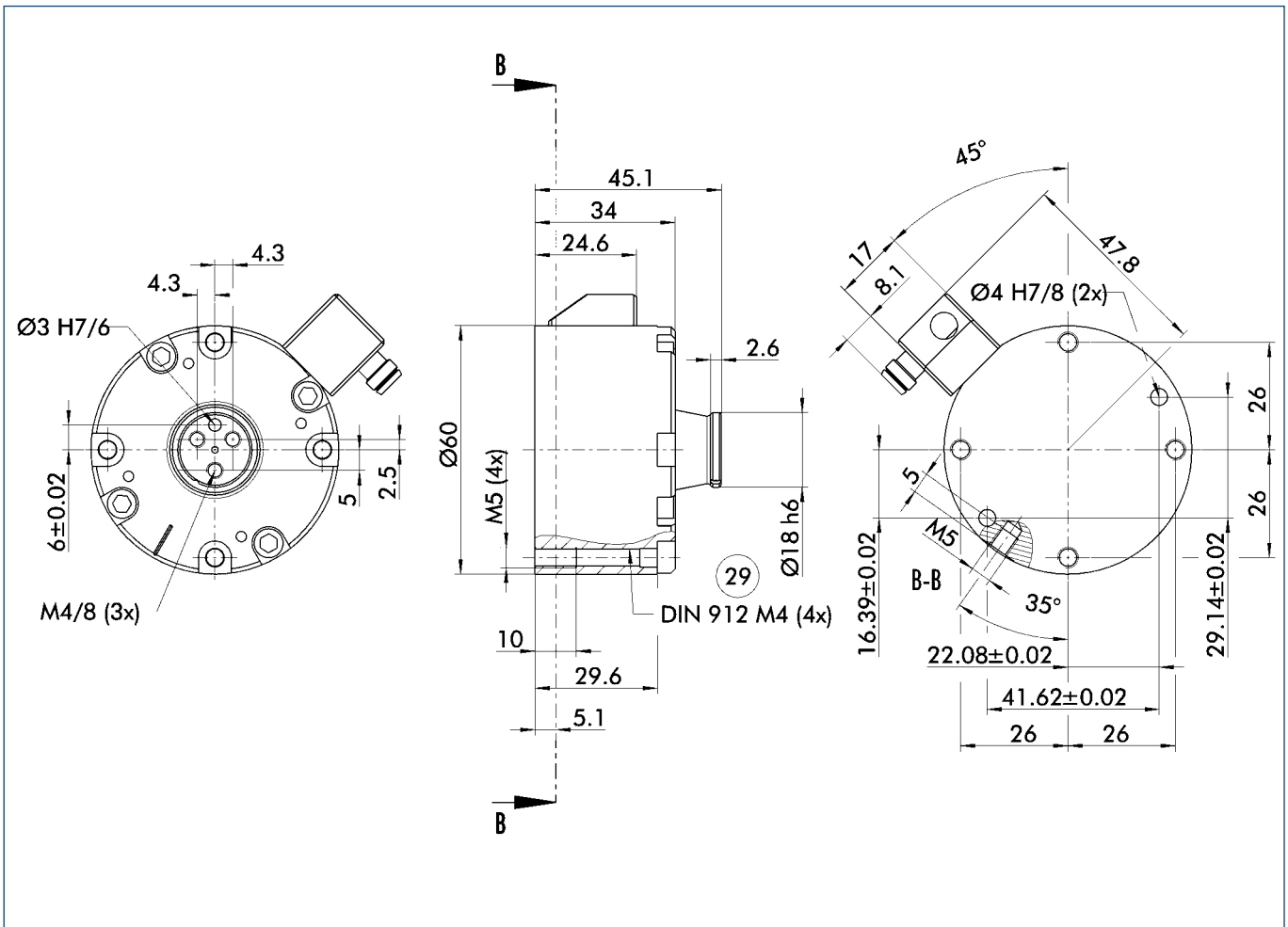

②9 Through-bore for screw connection

Moment load

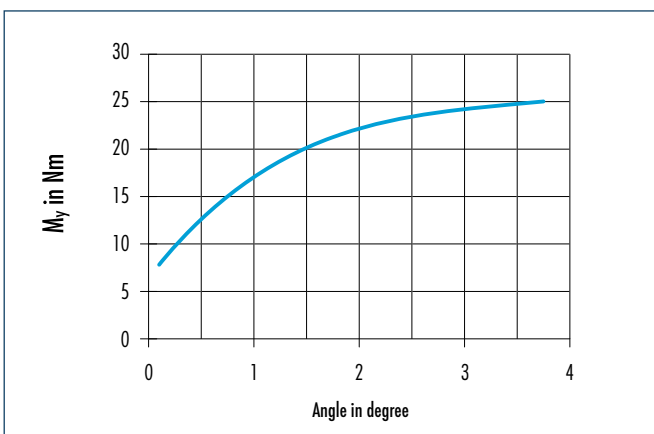

The diagram shows the actual deflection of the OPR, dependent upon the moment M_x at the maximum permissible operating pressure.

Force and moment range

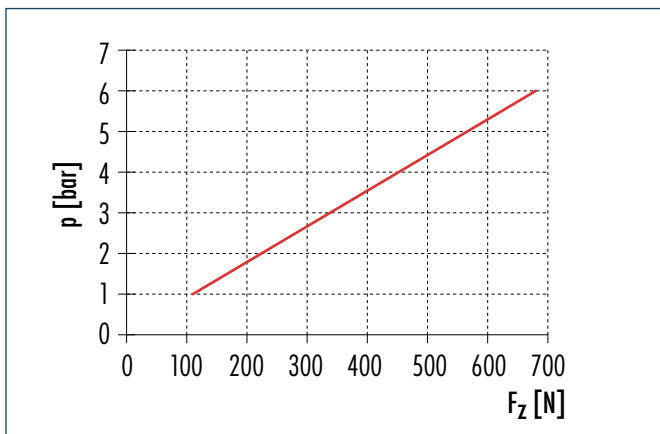

Axial (F_z)

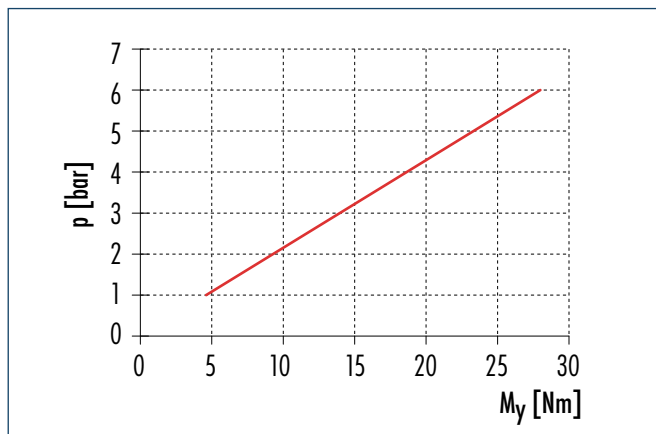

Moment (M_y)

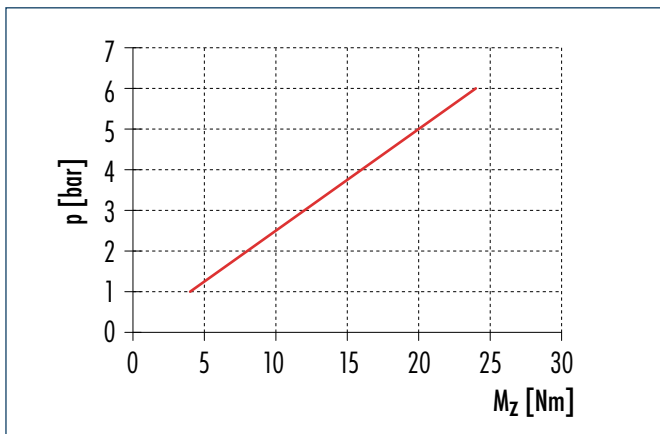

Torsion (M_z)

Adapter plate A40

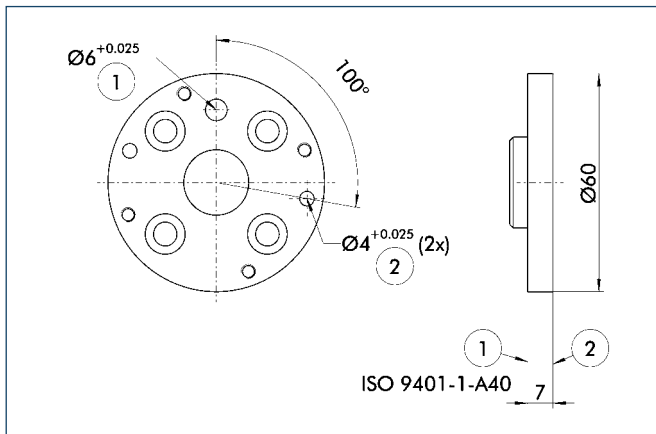

- ① Robot-side connection
- ② Tool-side connection

For mounting the OPR-061 directly to a flange in accordance with ISO 9409-40-4-M6

Designation	ID
A-OPR-061-ISO-A40-R	0321370

Adapter plate A50

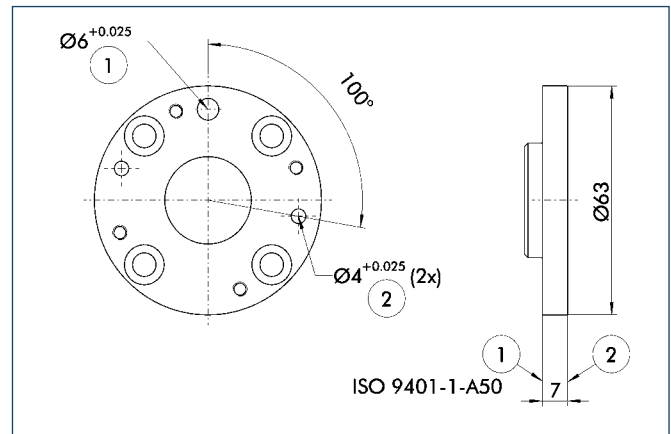

- ① Robot-side connection
- ② Tool-side connection

For mounting the OPR-061 directly to a flange in accordance with ISO 9409-50-4-M6

Designation	ID
A-OPR-061-ISO-A50-R	0321371

OPR-081

Protecting · Collision and Overload Protection



Forces and moments

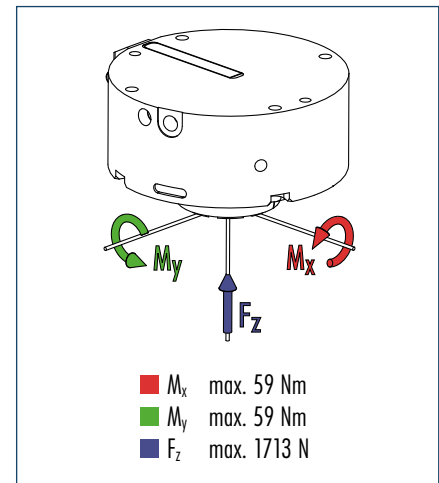

Technical data

Designation		OPR-081-P00	OPR-081-P05	OPR-081-P10	OPR-081-P15
ID without splash protection		0321381	0321382	0321383	0321384
ID with splash protection		0321385	0321386	0321387	0321388
Axial compensation	[mm]	8.5	8.5	8.5	8.5
Angular compensation	[°]	± 13	± 13	± 13	± 13
Rotational compensation	[°]	± 25	± 25	± 25	± 25
Triggering force with maximum operating pressure	[N]	1713	1713	1713	1713
Triggering torque with maximum operating pressure	Angular [Nm]	59	59	59	59
	Rotational [Nm]	61	61	61	61
Triggering force safeguarded by springs	[N]	-	95	190	285
Triggering torque safeguarded by springs	Angular [Nm]	-	3.2	6.4	9.6
	Rotational [Nm]	-	3.4	6.8	10.2
Maximum operating pressure	[bar]	6.0	5.7	5.4	5.1
Repeat accuracy	[mm]	± 0.025	± 0.025	± 0.025	± 0.025
Rotational repeat accuracy	[min]	± 5	± 5	± 5	± 5
Sensitivity	[mm]	0.5	0.5	0.5	0.5
Weight	[kg]	0.58	0.6	0.6	0.6

Force and moment range

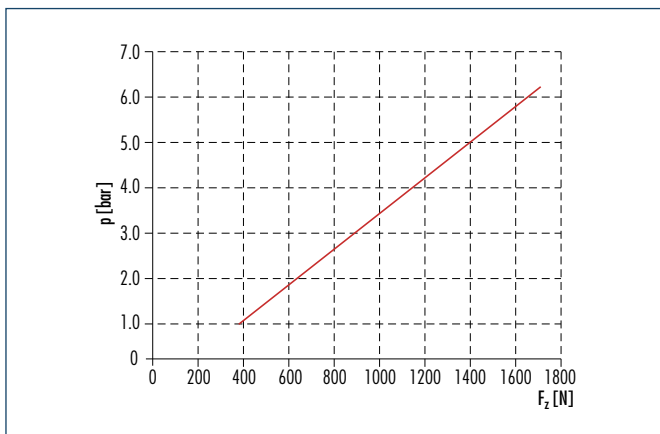

Axial (F_z)

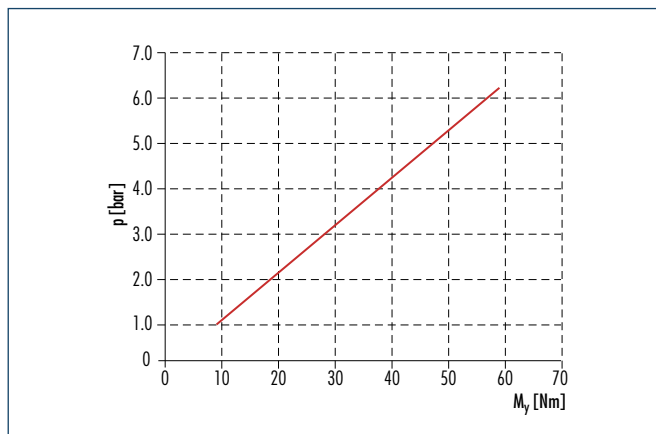

Moment (M_y)

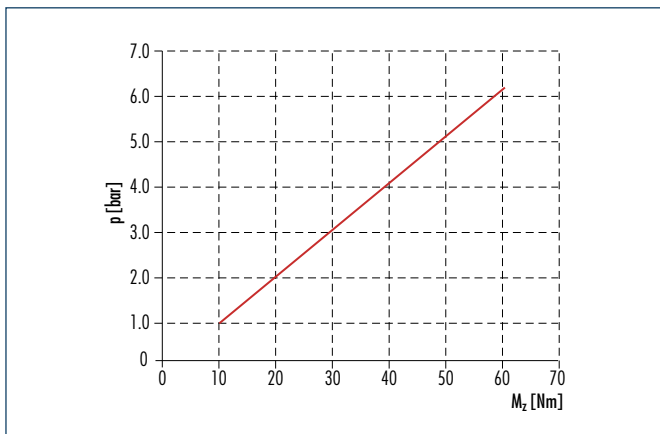

Torsion (M_z)

Adapter plate A50

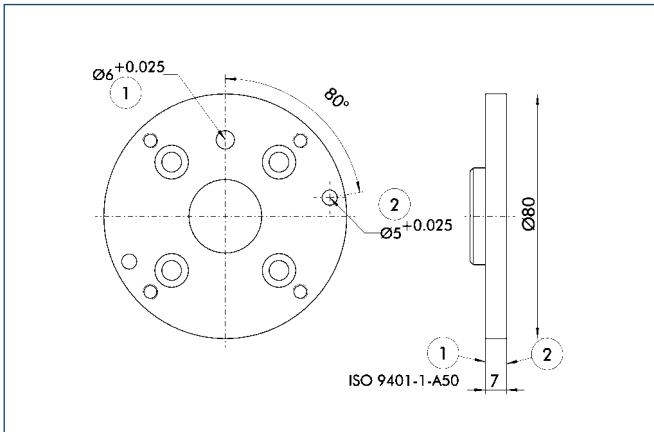

- ① Robot-side connection
- ② Tool-side connection

For mounting the OPR-081 directly to a flange in accordance with ISO 9409-50-4-M6

Designation	ID
A-OPR-081-ISO-A50-R	0321190

Adapter plate A63

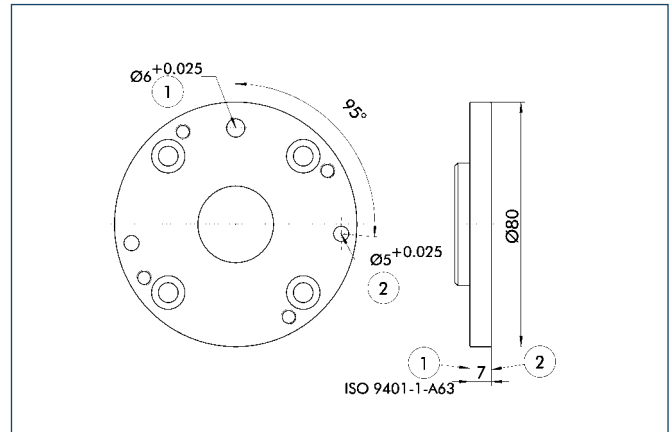

- ① Robot-side connection
- ② Tool-side connection

For mounting the OPR-081 directly to a flange in accordance with ISO 9409-63-4-M6

Designation	ID
A-OPR-081-ISO-A63-R	0321191



Forces and moments

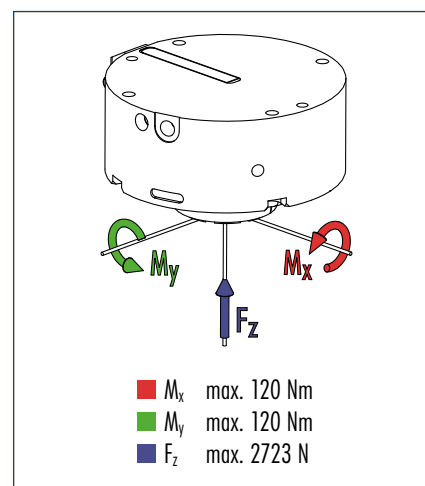

Technical data

Designation		OPR-101-P00	OPR-101-P05	OPR-101-P10	OPR-101-P15
ID without splash protection		0321401	0321402	0321403	0321404
ID with splash protection		0321405	0321406	0321407	0321408
Axial compensation	[mm]	10	10	10	10
Angular compensation	[°]	± 12	± 12	± 12	± 12
Rotational compensation	[°]	± 25	± 25	± 25	± 25
Triggering force with maximum operating pressure	[N]	2723	2723	2723	2723
Triggering torque with maximum operating pressure	Angular [Nm]	120	120	120	120
	Rotational [Nm]	130	130	130	130
Triggering force safeguarded by springs	[N]	-	150	300	450
Triggering torque safeguarded by springs	Angular [Nm]	-	6.6	13.3	20
	Rotational [Nm]	-	7.2	14.4	21.6
Maximum operating pressure	[bar]	6.0	5.7	5.4	5.1
Repeat accuracy	[mm]	± 0.025	± 0.025	± 0.025	± 0.025
Rotational repeat accuracy	[min]	± 5	± 5	± 5	± 5
Sensitivity	[mm]	0.5	0.5	0.5	0.5
Weight	[kg]	1.2	1.3	1.3	1.3

Main views

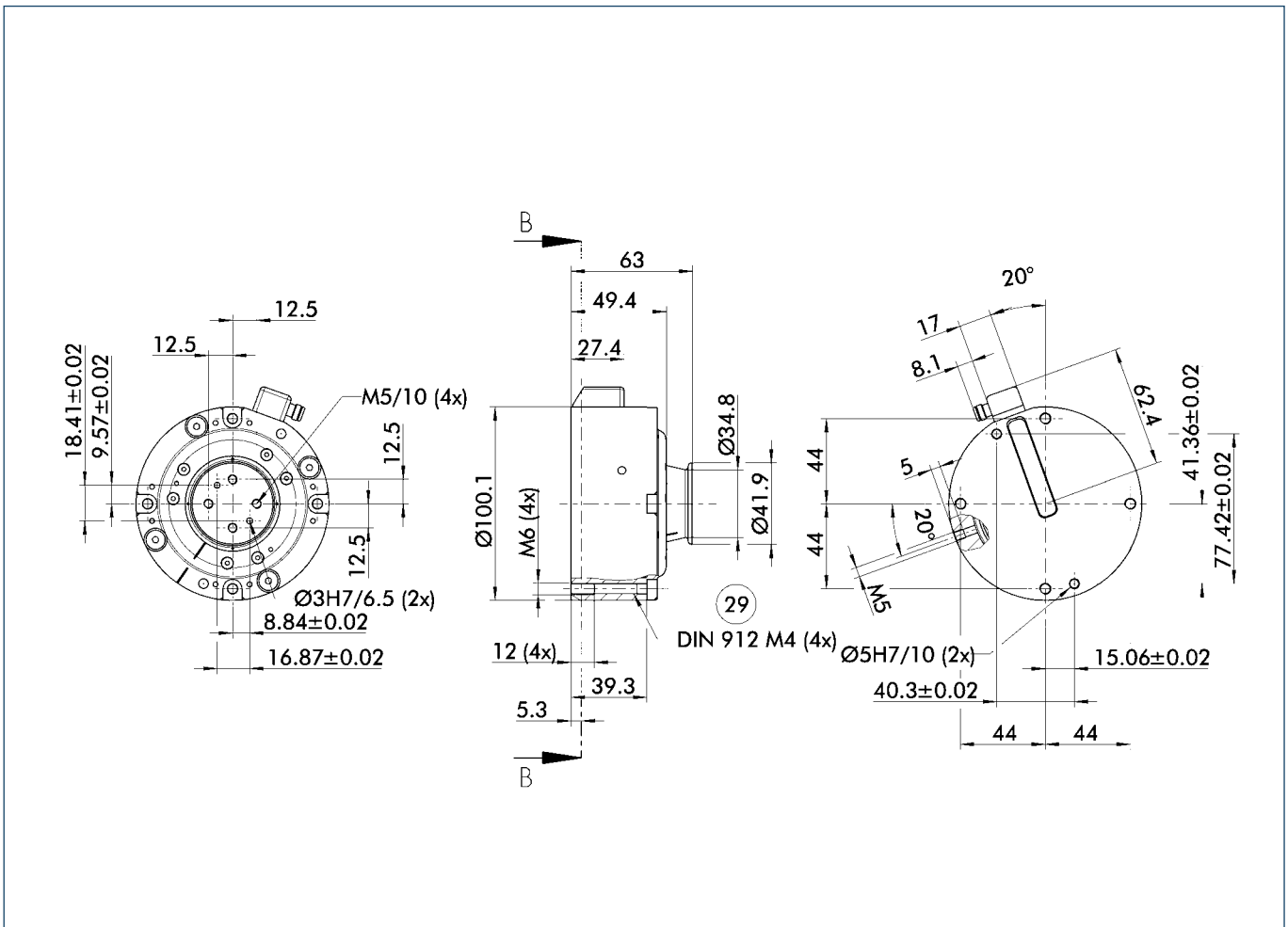

②⑨ Through-bore for screw connection

Moment load

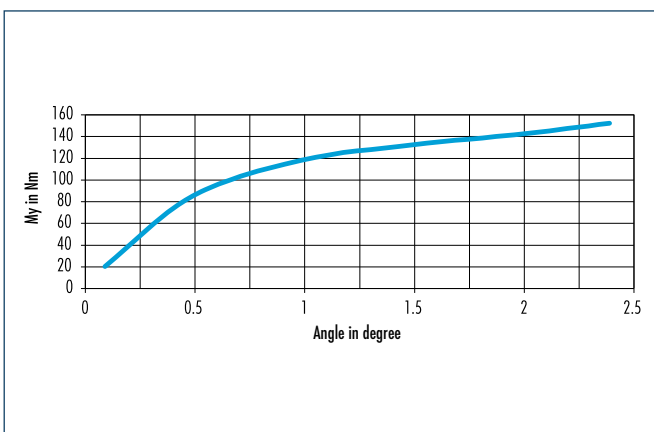

The diagram shows the actual deflection of the OPR, dependent upon the moment M_x at the maximum permissible operating pressure.

Force and moment range

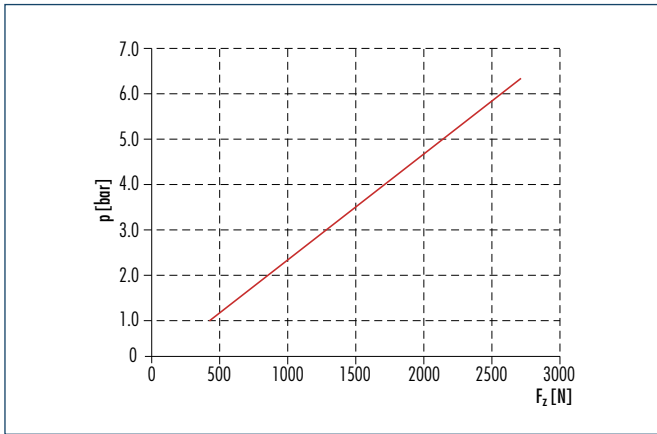

Axial (F_z)

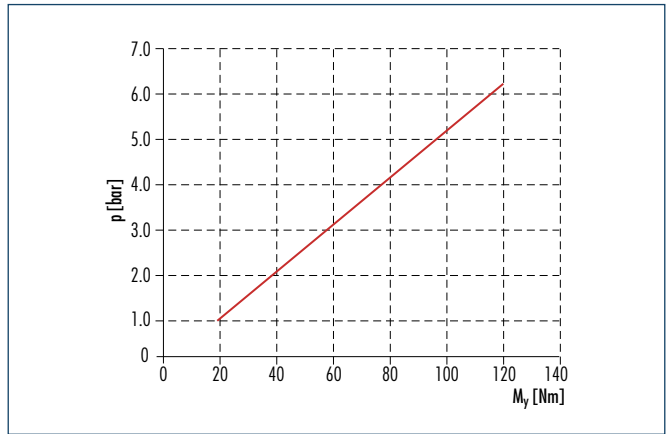

Moment (M_y)

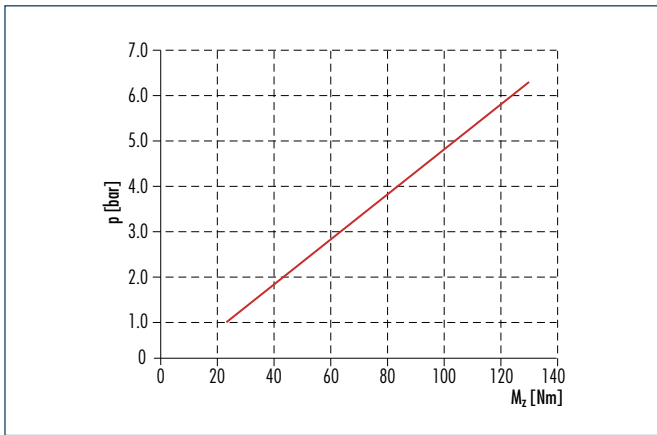

Torsion (M_z)

Adapter plate A50

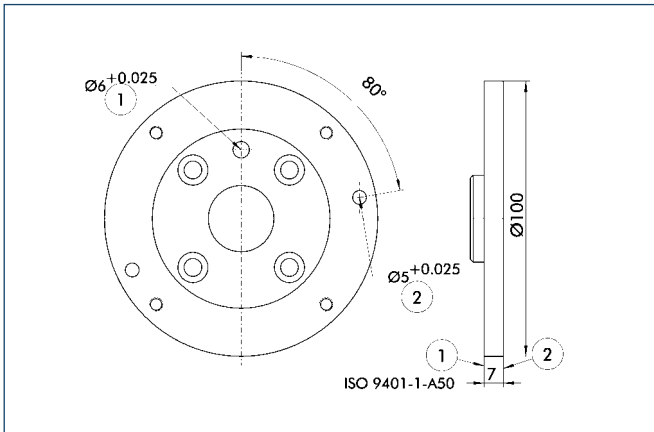

- ① Robot-side connection
- ② Tool-side connection

For mounting the OPR-101 directly to a flange in accordance with ISO 9409-50-4-M6

Designation	ID
A-OPR-101-ISO-A50-R	0321410

Adapter plate A63

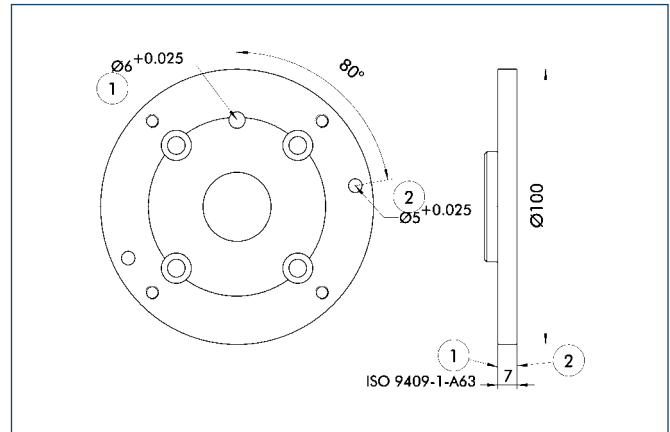

- ① Robot-side connection
- ② Tool-side connection

For mounting the OPR-101 directly to a flange in accordance with ISO 9409-63-4-M6

Designation	ID
A-OPR-101-ISO-A63-R	0321411

Adapter plate A80

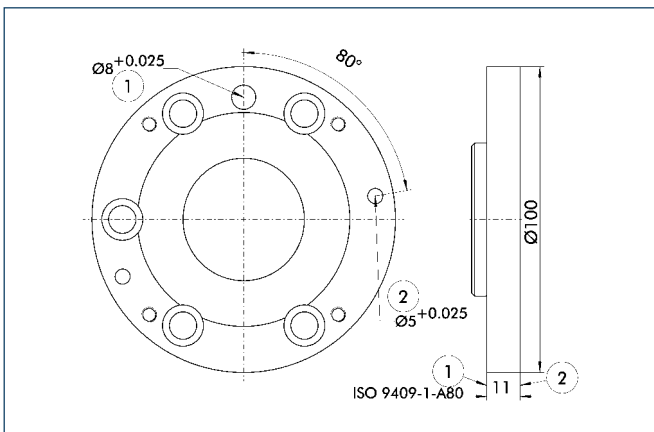

- ① Robot-side connection
- ② Tool-side connection

For mounting the OPR-101 directly to a flange in accordance with ISO 9409-80-6-M8

Designation	ID
A-OPR-101-ISO-A80-R	0321412

OPR-131

Protecting · Collision and Overload Protection



Forces and moments

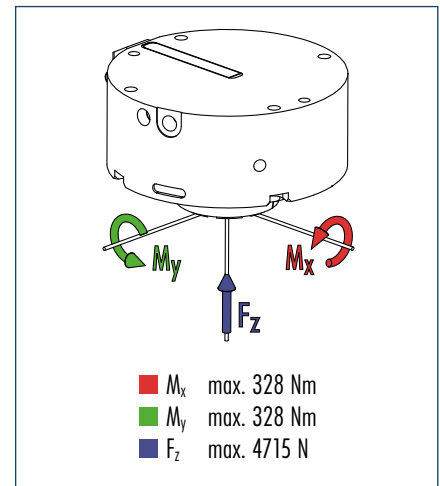

Technical data

Designation		OPR-131-P00	OPR-131-P05	OPR-131-P10	OPR-131-P15
ID without splash protection		0321431	0321432	0321433	0321434
ID with splash protection		0321435	0321436	0321437	0321438
Axial compensation	[mm]	11.5	11.5	11.5	11.5
Angular compensation	[°]	± 10	± 10	± 10	± 10
Rotational compensation	[°]	± 20	± 20	± 20	± 20
Triggering force with maximum operating pressure	[N]	4715	4715	4715	4715
Triggering torque with maximum operating pressure	Angular [Nm]	328	328	328	328
	Rotational [Nm]	303	303	303	303
Triggering force safeguarded by springs	[N]	-	262	524	785
Triggering torque safeguarded by springs	Angular [Nm]	-	18	36	54
	Rotational [Nm]	-	19	38	57
Maximum operating pressure	[bar]	6.0	5.7	5.4	5.1
Repeat accuracy	[mm]	± 0.025	± 0.025	± 0.025	± 0.025
Rotational repeat accuracy	[min]	± 5	± 5	± 5	± 5
Sensitivity	[mm]	0.5	0.5	0.5	0.5
Weight	[kg]	2.3	2.4	2.4	2.4

Main views

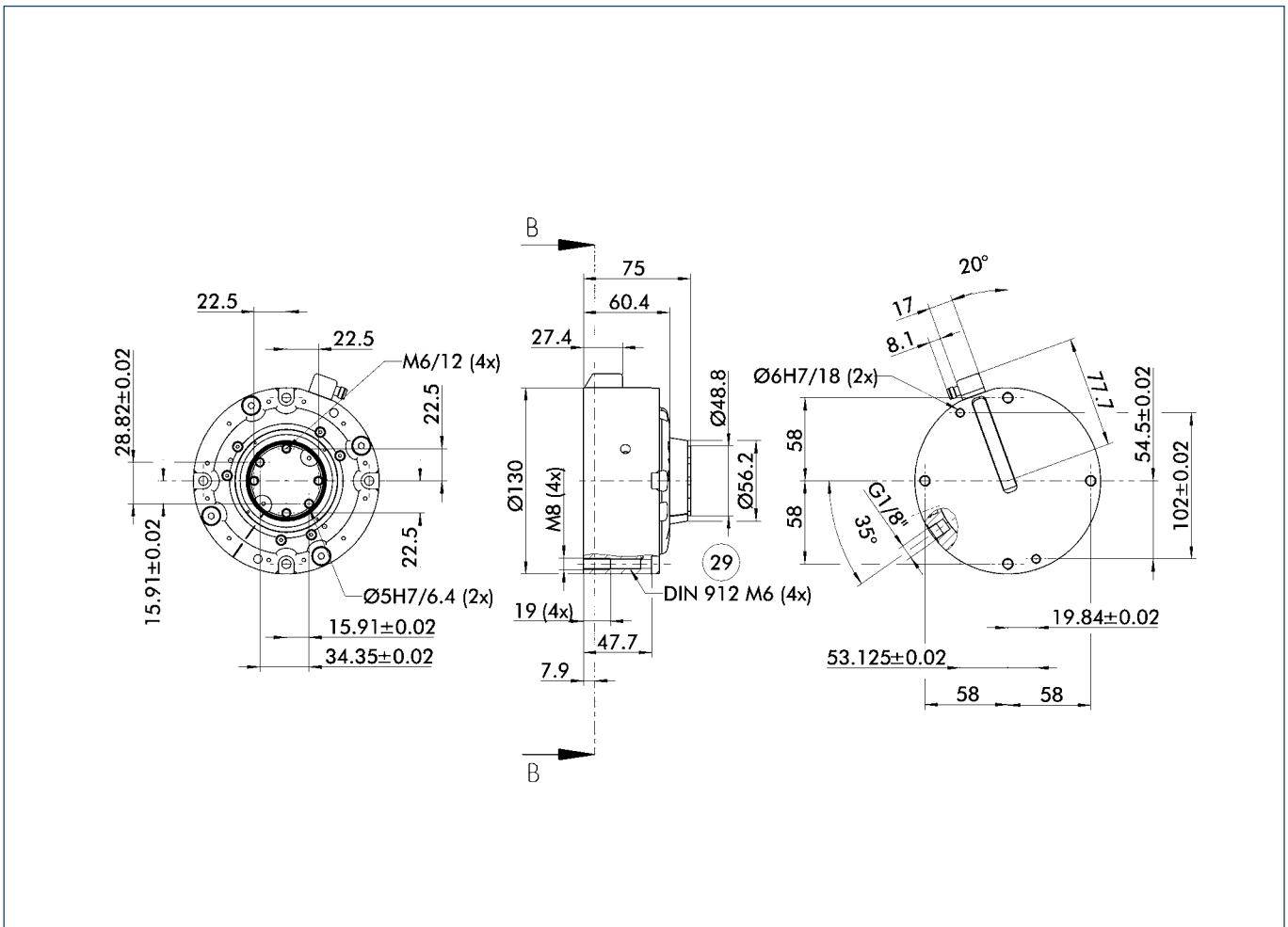

②9 Through-bore for screw connection

Moment load

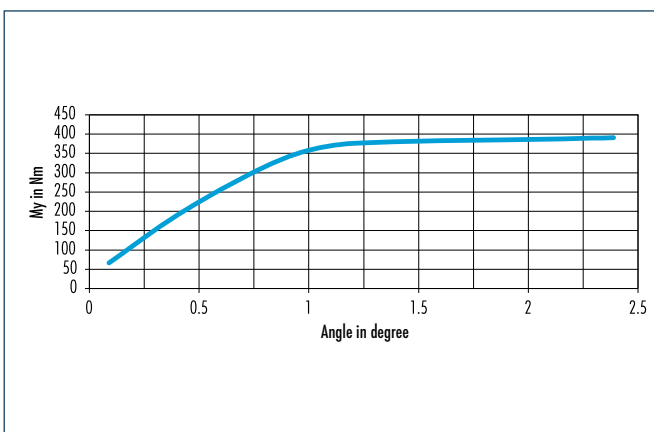

The diagram shows the actual deflection of the OPR, dependent upon the moment M_x at the maximum permissible operating pressure.

Force and moment range

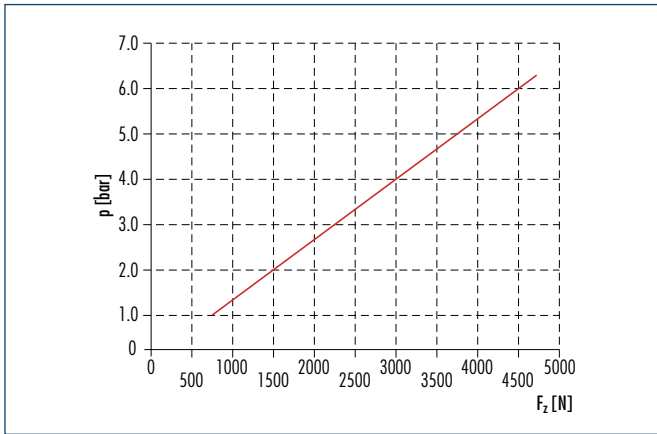

Axial (F_z)

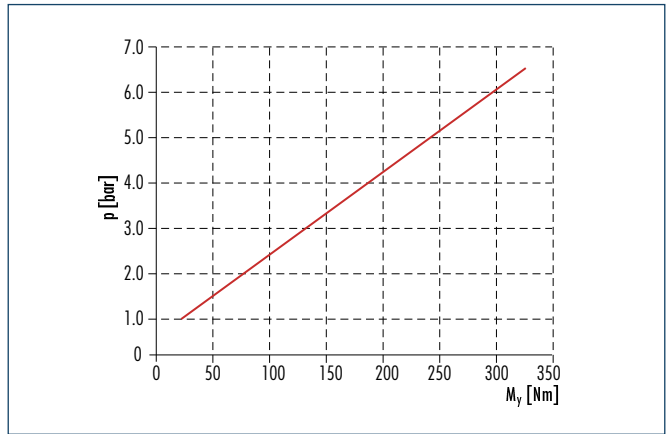

Moment (M_y)

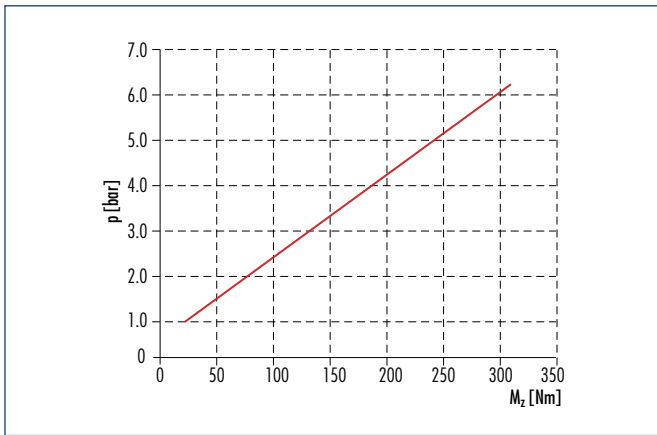

Torsion (M_z)

Adapter plate A80

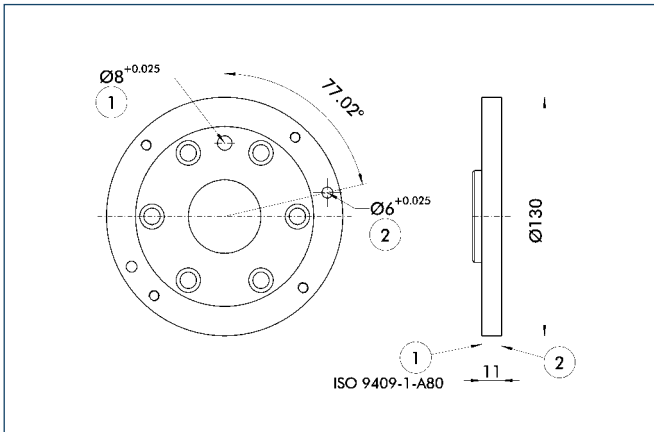

- ① Robot-side connection
- ② Tool-side connection

For mounting the OPR-131 directly to a flange in accordance with ISO 9409-80-6-M8

Designation	ID
A-OPR-131-ISO-A80-R	0321440

Adapter plate A100

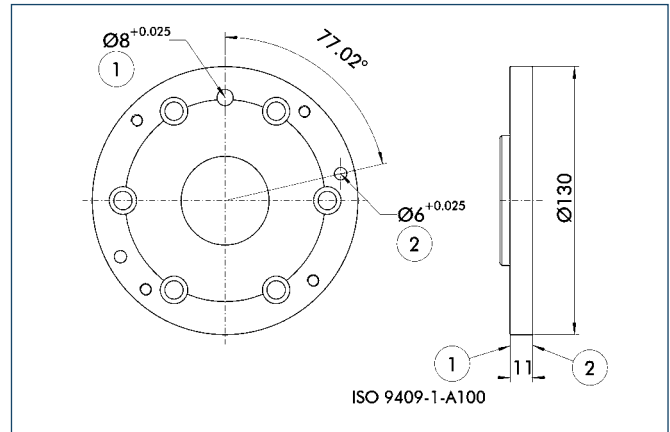

- ① Robot-side connection
- ② Tool-side connection

For mounting the OPR-131 directly to a flange in accordance with ISO 9409-100-6-M8

Designation	ID
A-OPR-131-ISO-A100-R	0321441



OPR-176

Protecting · Collision and Overload Protection



Forces and moments

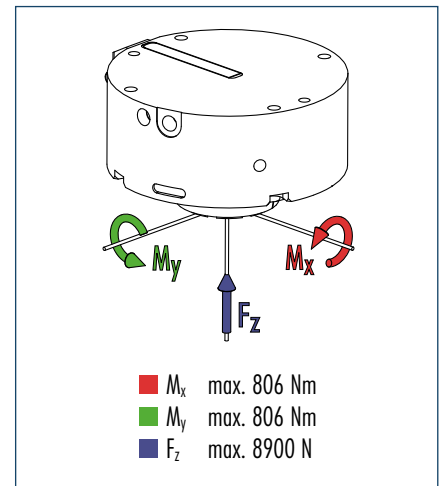

Technical data

Designation		OPR-176-P00	OPR-176-P05	OPR-176-P10	OPR-176-P15
ID without splash protection		0321476	0321477	0321478	0321479
ID with splash protection		0321480	0321481	0321482	0321483
Axial compensation	[mm]	16	16	16	16
Angular compensation	[°]	± 10	± 10	± 10	± 10
Rotational compensation	[°]	± 20	± 20	± 20	± 20
Triggering force with maximum operating pressure	[N]	8900	8900	8900	8900
Triggering torque with maximum operating pressure	Angular [Nm]	806	806	806	806
	Rotational [Nm]	543	543	543	543
Triggering force safeguarded by springs	[N]	-	494	989	1483
Triggering torque safeguarded by springs	Angular [Nm]	-	45	90	135
	Rotational [Nm]	-	46	92	138
Maximum operating pressure	[bar]	6.0	5.7	5.4	5.1
Repeat accuracy	[mm]	± 0.025	± 0.025	± 0.025	± 0.025
Rotational repeat accuracy	[min]	± 5	± 5	± 5	± 5
Sensitivity	[mm]	0.5	0.5	0.5	0.5
Weight	[kg]	5.3	5.4	5.4	5.4

Main views

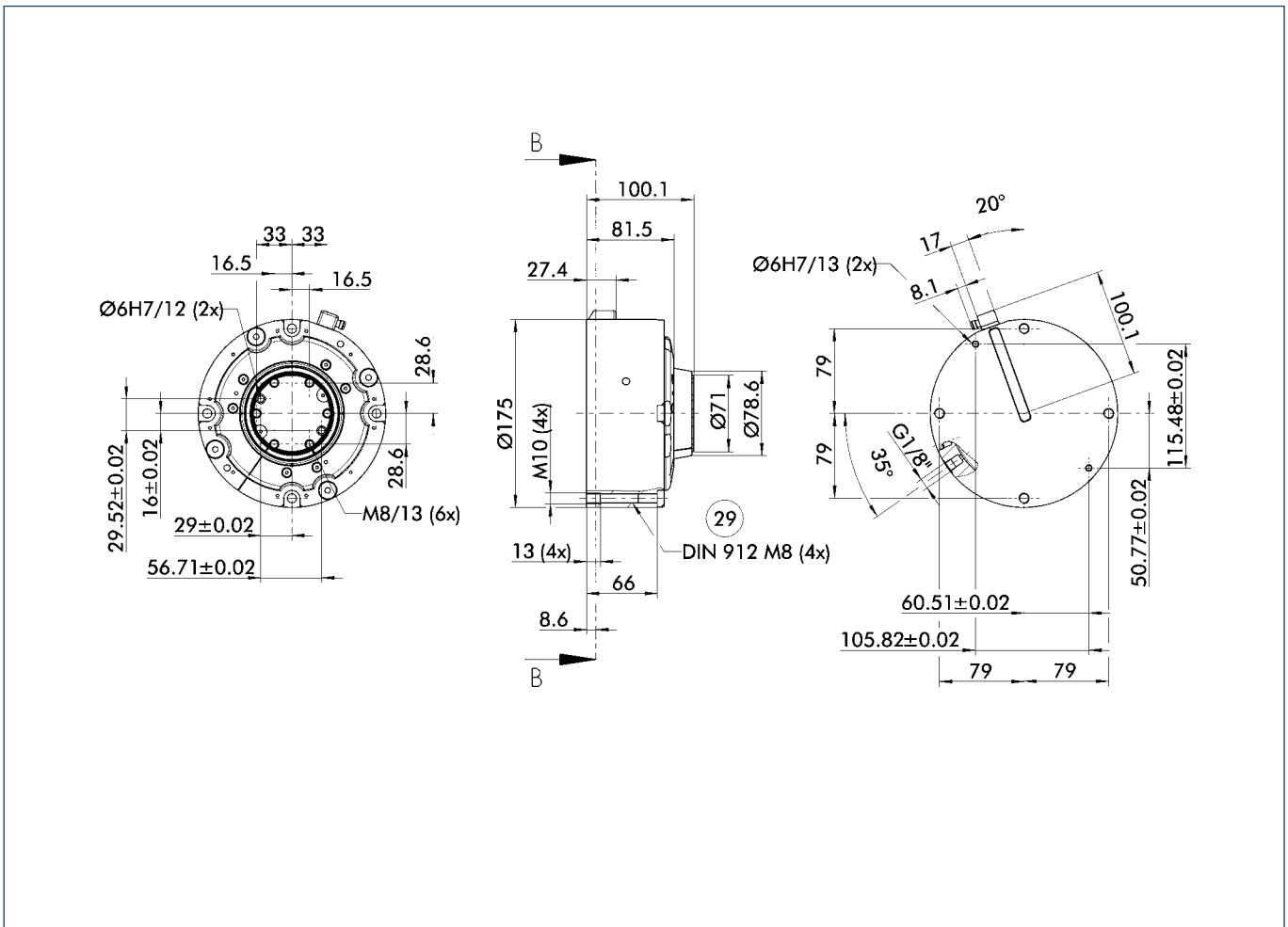

29 Through-bore for screw connection

Moment load

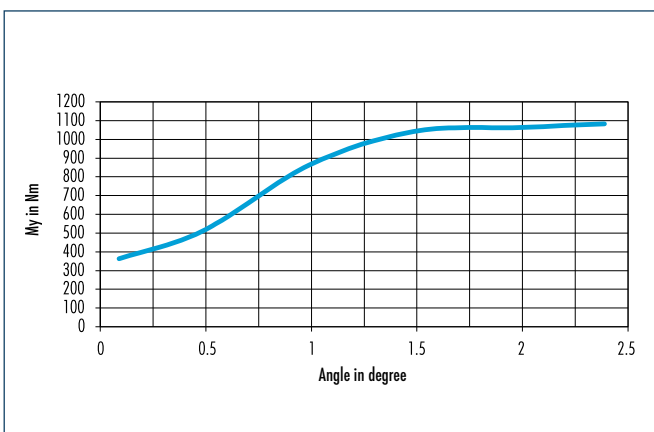

The diagram shows the actual deflection of the OPR, dependent upon the moment M_x at the maximum permissible operating pressure.

Force and moment range

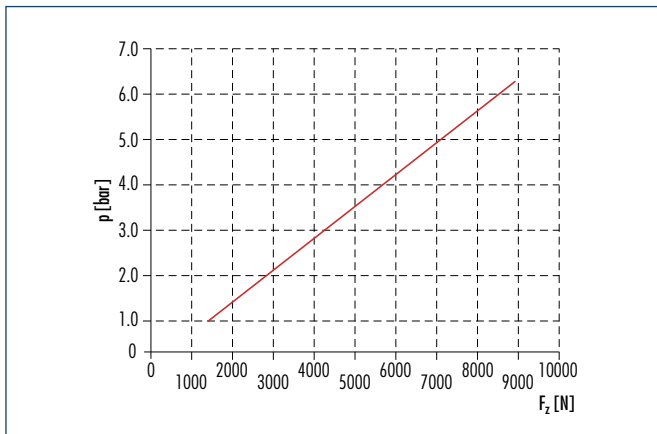

Axial (F_z)

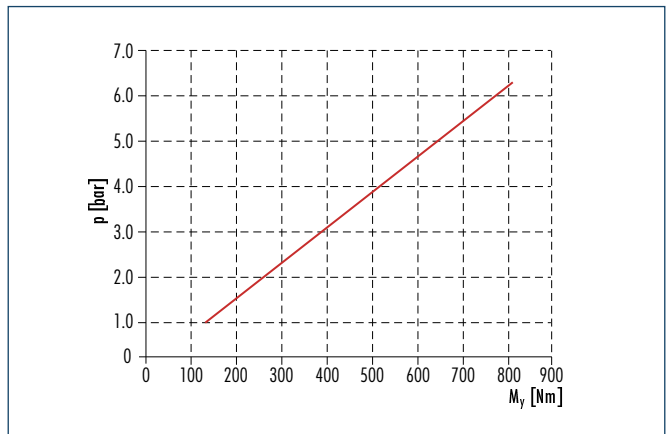

Moment (M_y)

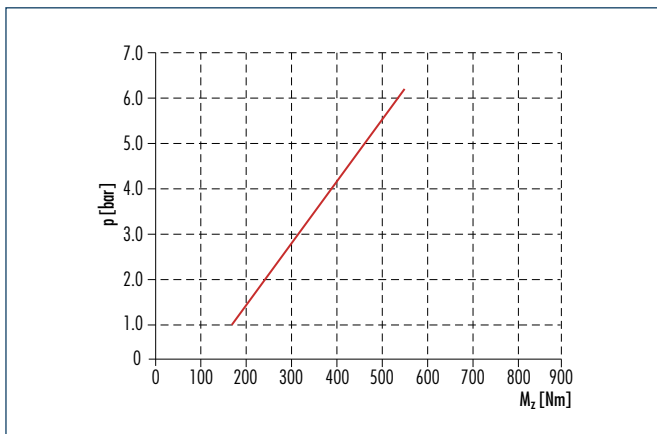

Torsion (M_z)

Adapter plate A125

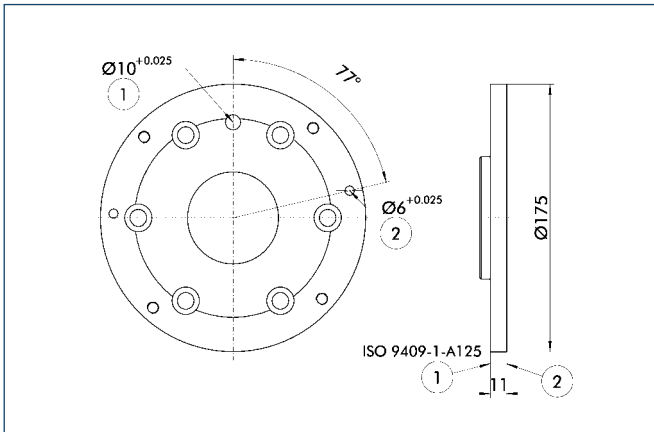

- ① Robot-side connection
- ② Tool-side connection

For mounting the OPR-176 directly to a flange in accordance with ISO 9409-125-6-M10

Designation	ID
A-OPR-176-ISO-A125-R	0321485

Adapter plate A160

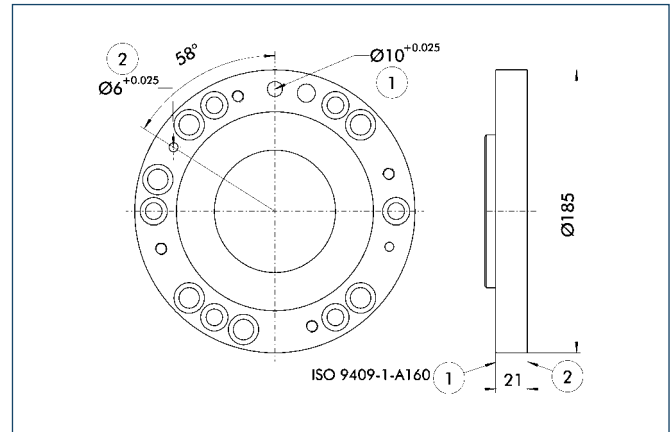

- ① Robot-side connection
- ② Tool-side connection

For mounting the OPR-176 directly to a flange in accordance with ISO 9409-160-6-M10 and ISO 9409-160-11-M12

Designation	ID
A-OPR-176-ISO-A160-R	0321486



Forces and moments

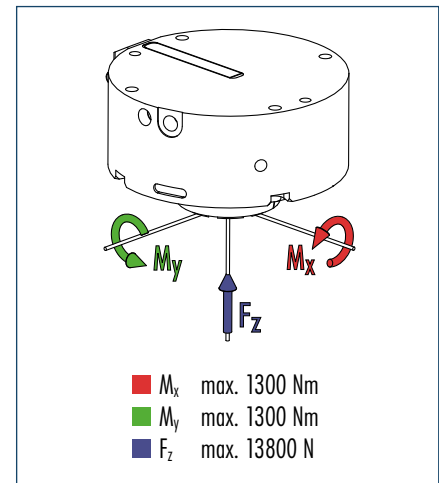

Technical data

Designation		OPR-221-P00	OPR-221-P05	OPR-221-P10	OPR-221-P15
ID without splash protection		0321521	0321522	0321523	0321524
ID with splash protection		0321525	0321526	0321527	0321528
Axial compensation	[mm]	16	16	16	16
Angular compensation	[°]	± 8	± 8	± 8	± 8
Rotational compensation	[°]	± 20	± 20	± 20	± 20
Triggering force with maximum operating pressure	[N]	13800	13800	13800	13800
Triggering torque with maximum operating pressure	Angular [Nm]	1300	1300	1300	1300
	Rotational [Nm]	960	960	960	960
Triggering force safeguarded by springs	[N]	-	766	1532	2298
Triggering torque safeguarded by springs	Angular [Nm]	-	72	144	216
	Rotational [Nm]	-	82	164	246
Maximum operating pressure	[bar]	6.0	5.7	5.4	5.1
Repeat accuracy	[mm]	± 0.025	± 0.025	± 0.025	± 0.025
Rotational repeat accuracy	[min]	± 5	± 5	± 5	± 5
Sensitivity	[mm]	0.5	0.5	0.5	0.5
Weight	[kg]	11.4	11.7	11.7	11.7

Main views

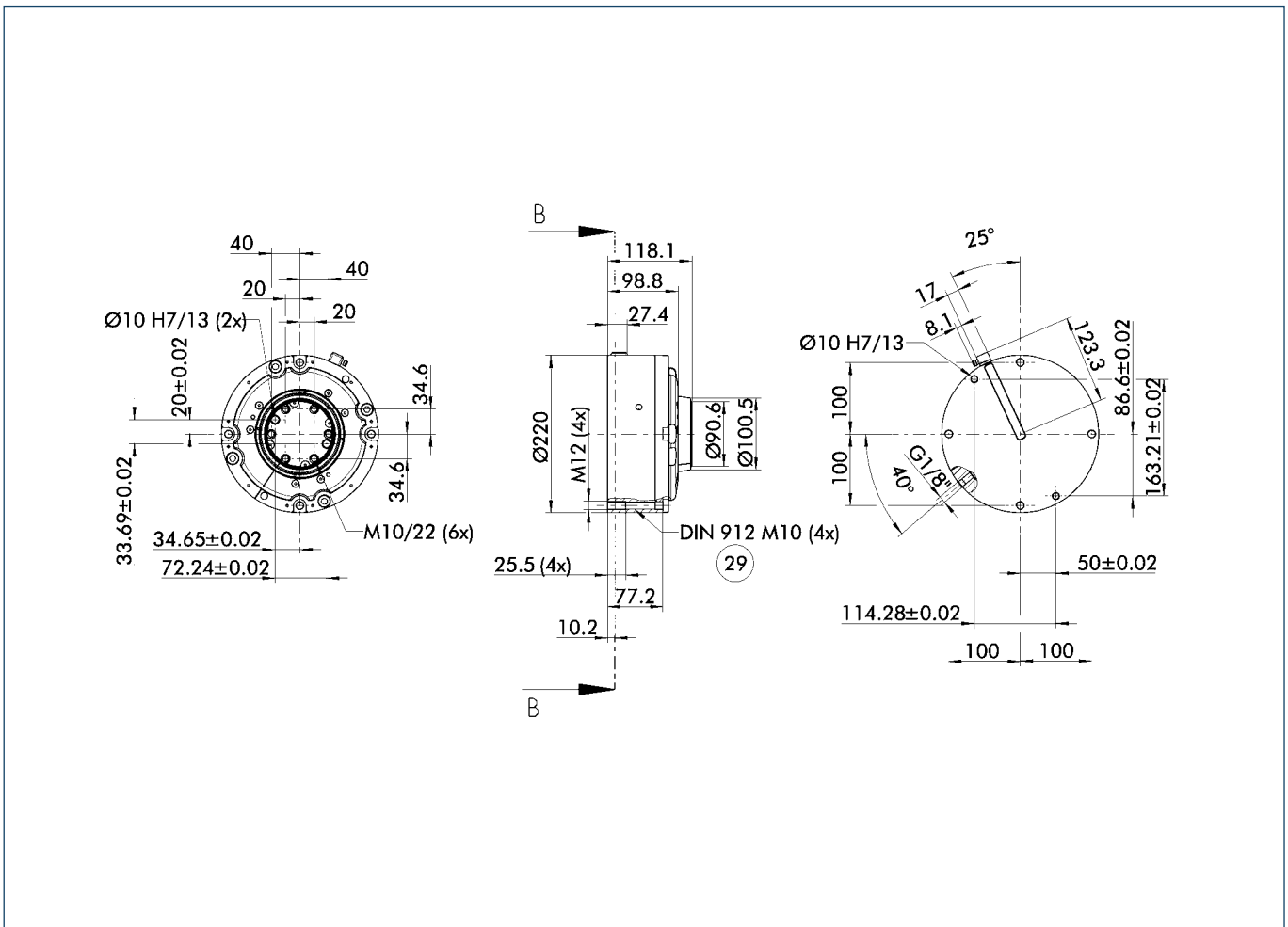

⑲ Through-bore for screw connection

Moment load

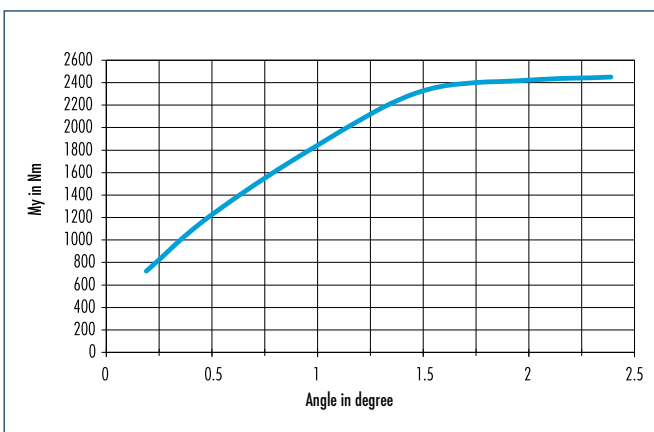

The diagram shows the actual deflection of the OPR, dependent upon the moment M_x at the maximum permissible operating pressure.

Force and moment range

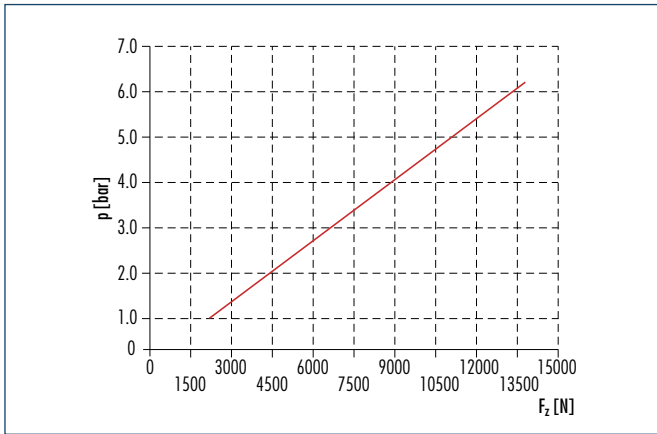

Axial (F_z)

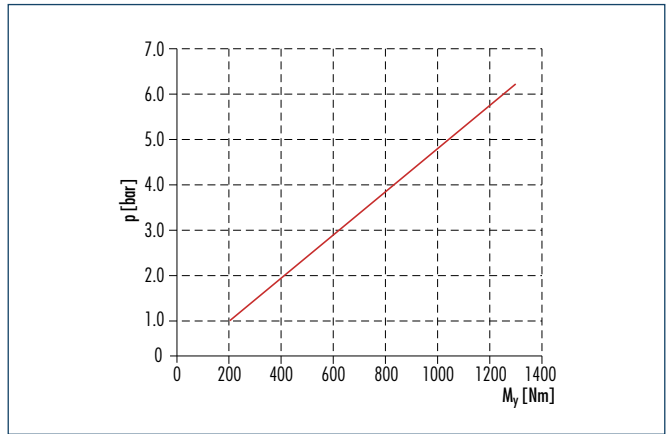

Moment (M_y)

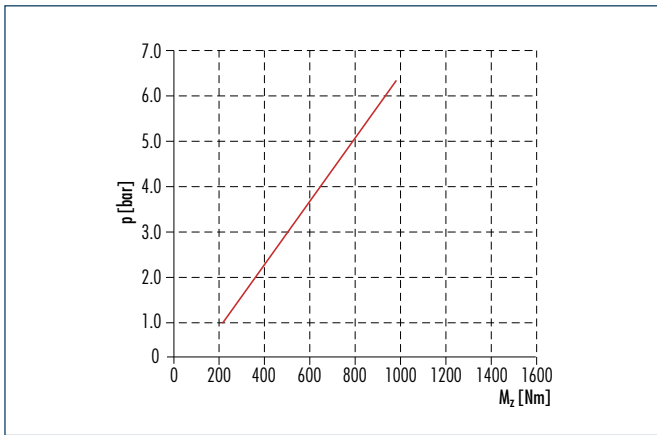

Torsion (M_z)

Adapter plate A160

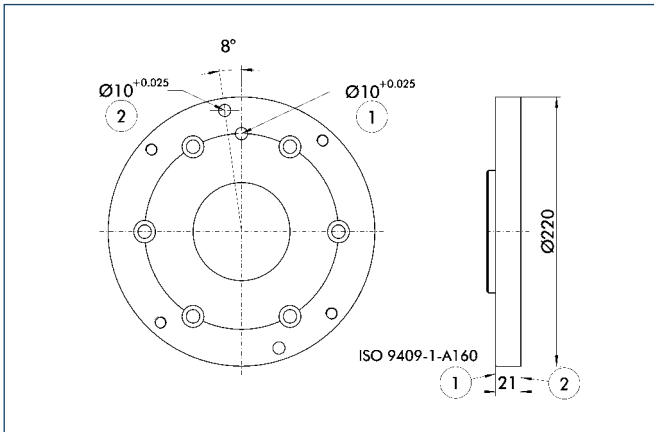

- ① Robot-side connection
- ② Tool-side connection

For mounting the OPR-221 directly to a flange in accordance with ISO 9409-160-6-M10

Designation	ID
A-OPR-221-ISO-A160-R	0321530

Adapter plate A200

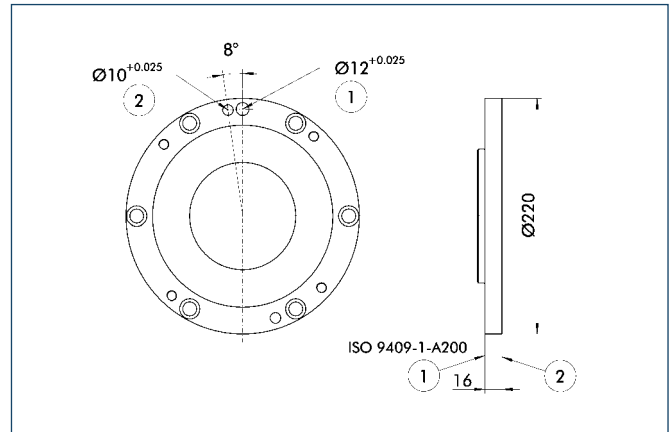

- ① Robot-side connection
- ② Tool-side connection

For mounting the OPR-221 directly to a flange in accordance with ISO 9409-200-6-M10

Designation	ID
A-OPR-221-ISO-A200-R	0321531



Compensation

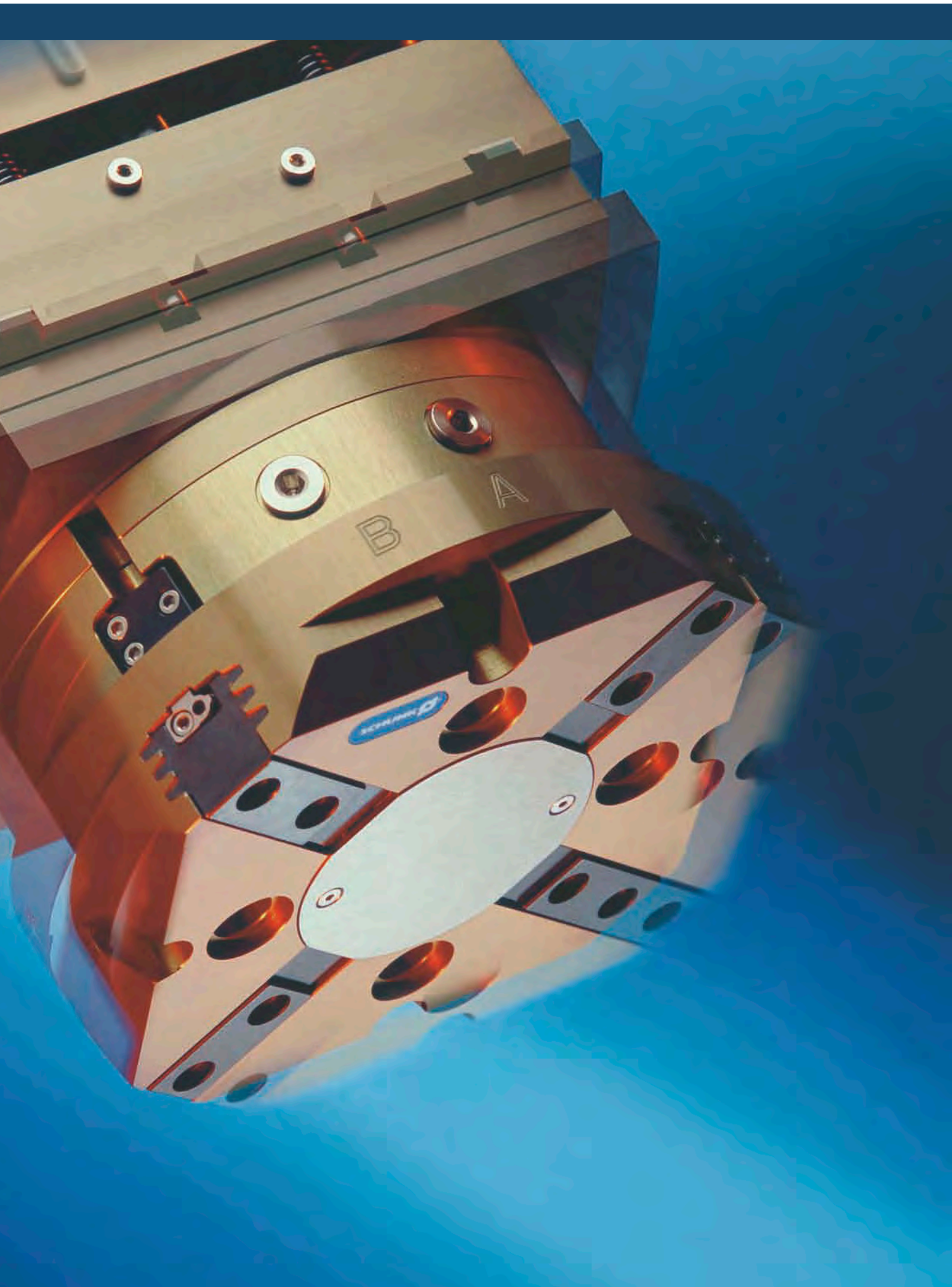

COMPENSATION

Series	Size	Page
Compensation Units Z		
AGE-Z		310
AGE-Z	050	314
AGE-Z	063	318
AGE-Z	080	322
Compensation Units XY		
AGE-XY		326
AGE-XY	050	330
AGE-XY	063	334
AGE-XY	080	338
Compensation Units F		
AGE-F		342
AGE-F	031	346
AGE-F	040	350
AGE-F	063	354
AGE-F	080	358
Compensation Units S		
AGE-S		362
AGE-S	100	366
AGE-S	125	370
AGE-S	160	374
AGE-S	200	378
Insertion Units		
FUS		382
FUS	001-30	388
FUS	001	390
FUS	100	392
FUS	200	394
FUS	400	396





Sizes
050 .. 080



Payload
1 kg .. 5 kg



Compensation paths Z
 ± 10 mm

Example for application

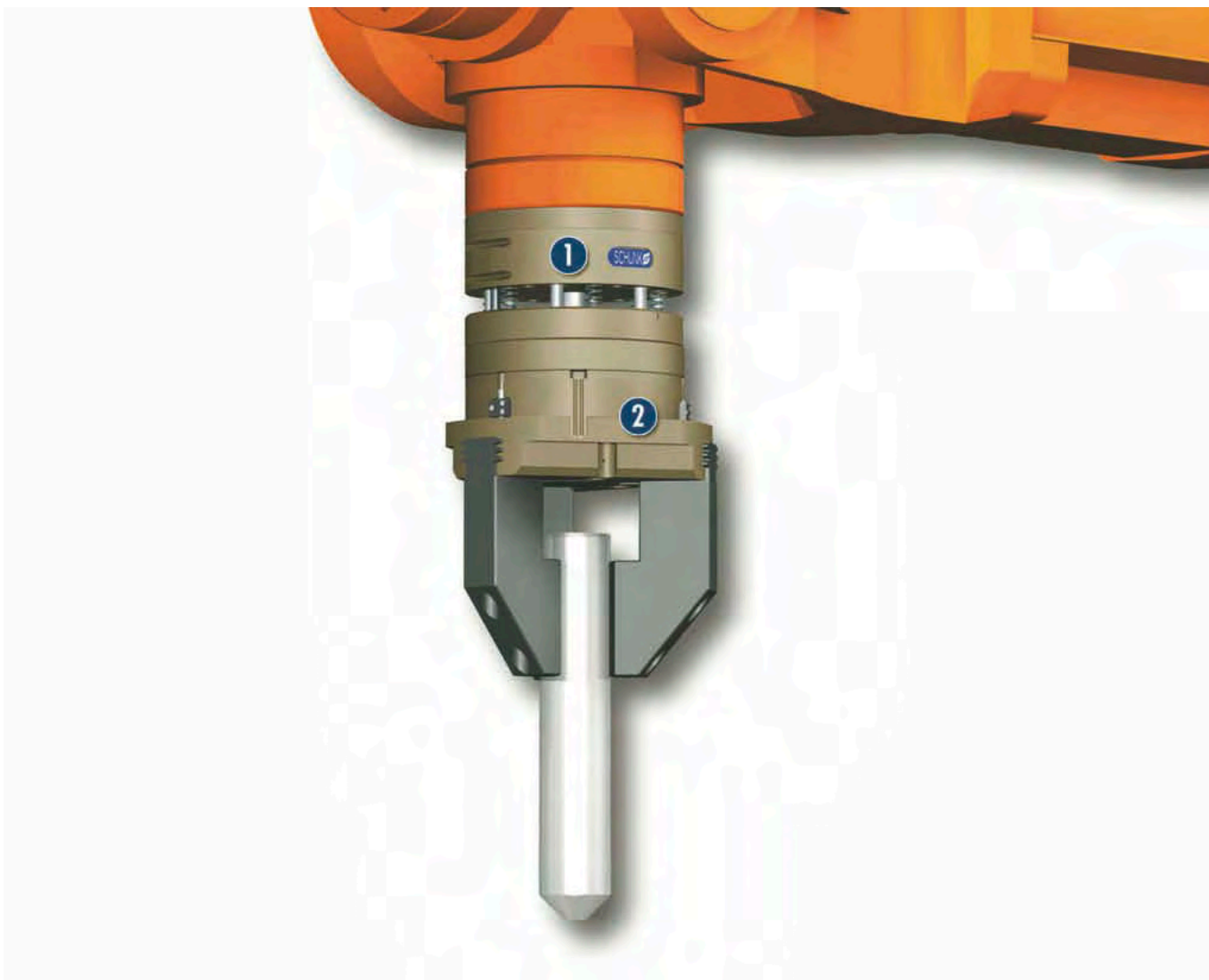

Compensation unit for handling of workpieces with different height tolerances. The compensation unit compensates the horizontal offset of the placing position.

1 Compensation Unit AGE-Z 80

2 3-Finger Centric Gripper PZN-plus 80 with workpiece-specific gripper fingers

Compensation Unit

Compensation unit with Z-axis yielding.

Area of application

Mounting, palletizing and insertion of workpieces

Benefits

ISO flange pattern

for easy mounting to most robot types without additional adapter plates

Locking device

for rigid switching of the unit in a defined extended or retracted position

Compact design

for minimum overall height

Can be combined with AGE-XY without additional adapter plate



General information on the series

Compensation path

Z-direction: up to 10 mm

Guides

Solid guides

Actuation

Pneumatic, filtered compressed air (10 µm): dry, lubricated or non-lubricated

Operating pressure range

2 bar to 8 bar

Monitoring of the Z-stroke

By magnetic switches

Ambient temperature

5° to 60° C

Material

Aluminum alloy, hard-anodized.
Functional components of hardened steel.

Warranty

24 months

Sectional diagram

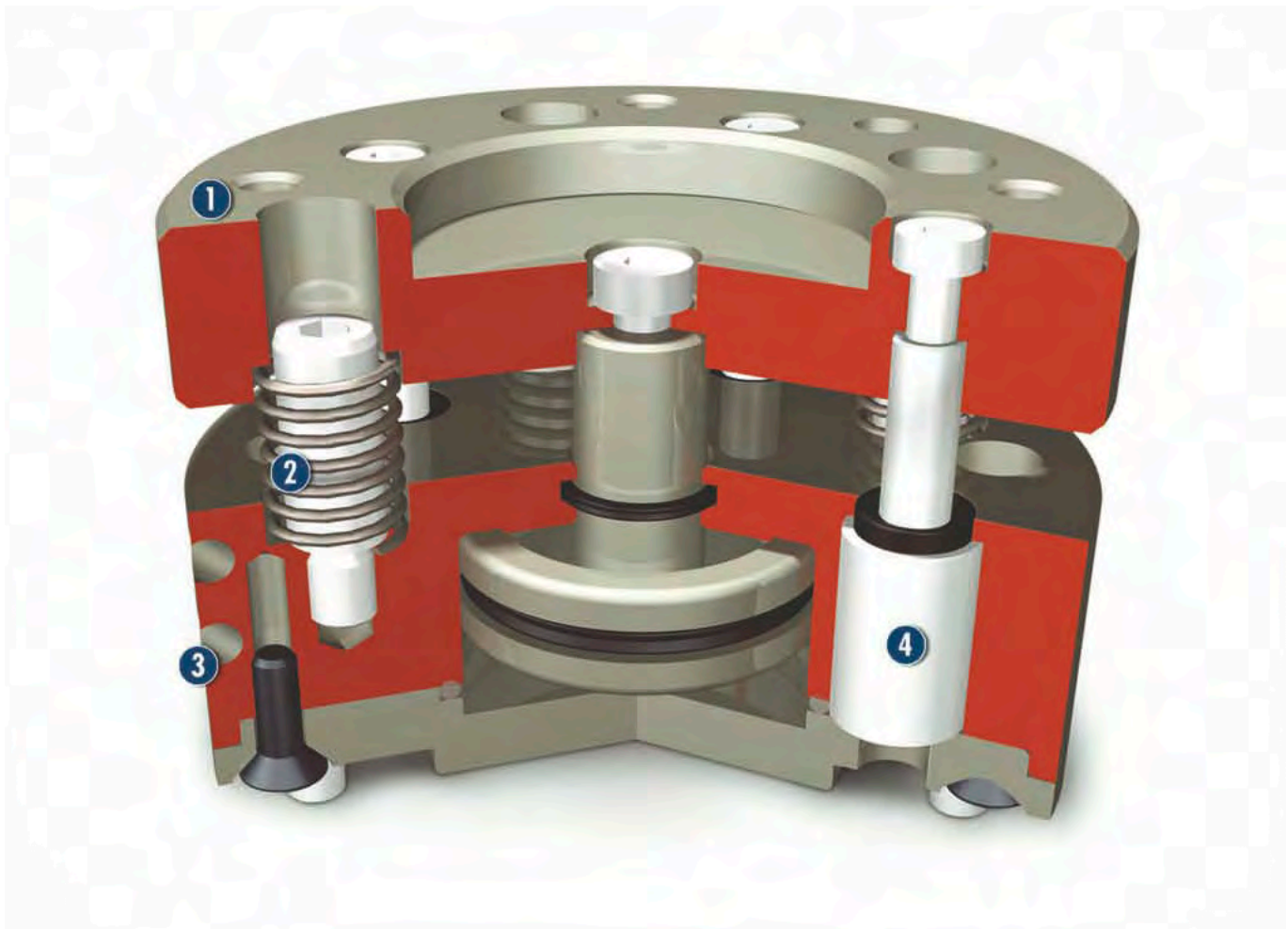

- 1 Housing**
weight-reduced due to use of a hard-anodized, high-strength aluminum alloy
- 2 Compression Springs**
for defined pressure forces during placing
- 3 Monitoring Groove**
Stroke monitoring of the locking piston with magnetic switches
- 4 Ball Guides are Free of Play**
for large maximum moments at a minimum size

Function description

The compensation unit AGE-Z enables a Z-compensation of different pickup and placing positions.

The compensation unit is guided by a ball guide without play.

Compression springs define the rigidity of the AGE-Z, which can be increased by additional actuation of the pneumatic cylinder.

The cylinder also enables locking of the unit during dynamic movements. The retracted and extended positions are monitored by means of magnetic switches.

Accessories

Accessories from SCHUNK – the suitable supplement for maximum functionality, reliability and performance of all automation modules.

Fittings



Magnetic switch MMS



Sensor cable



- ① The specific size of the desired accessories, availability for the model and the name and ID no. can be found in the additional diagrams following each model. For further information on our accessories, please consult the “Accessories” section of the catalog.

General information on the series

Extreme ambient conditions

Please be aware that use under extreme conditions (e.g. with coolants, or in the presence of casting dust or abrasive dust) can significantly reduce the tool life of these units, for which we can make no guarantee. In many cases, however, we have a solution. Please contact us.

AGE-Z 050

Compensation · Z Compensation Units · **Light Load**



Load diagram

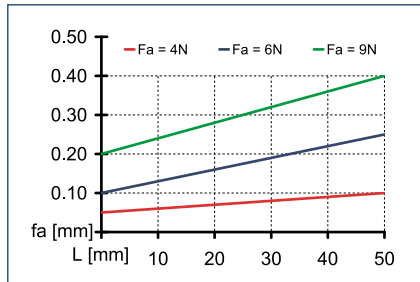
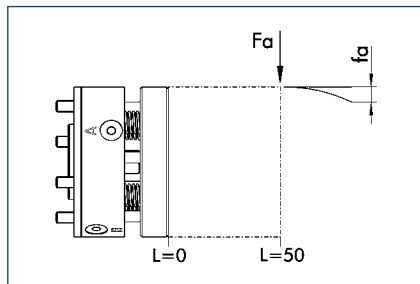

Deflection of the AGE-Z under load

Forces and moments

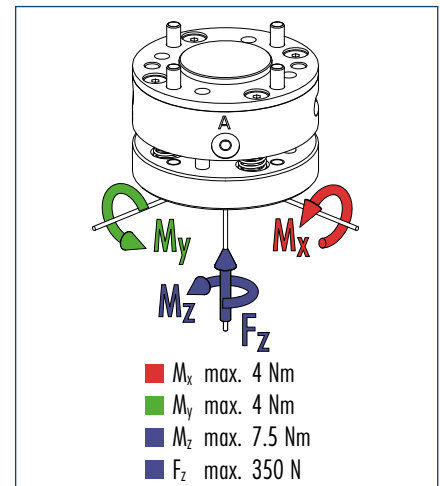

Technical data

Designation	AGE-Z-050	
	ID	0324452
Workpiece weight (recommendation)	[kg]	1.0
Compensation stroke	[mm]	8.0
Mounting, round mechanical interface		ISO 9409-50-4-M6
Spring force	[N]	10 - 30
Extend piston force at 6 bar	[N]	300
Retract piston force at 6 bar	[N]	270
Weight	[kg]	0.35

Main views

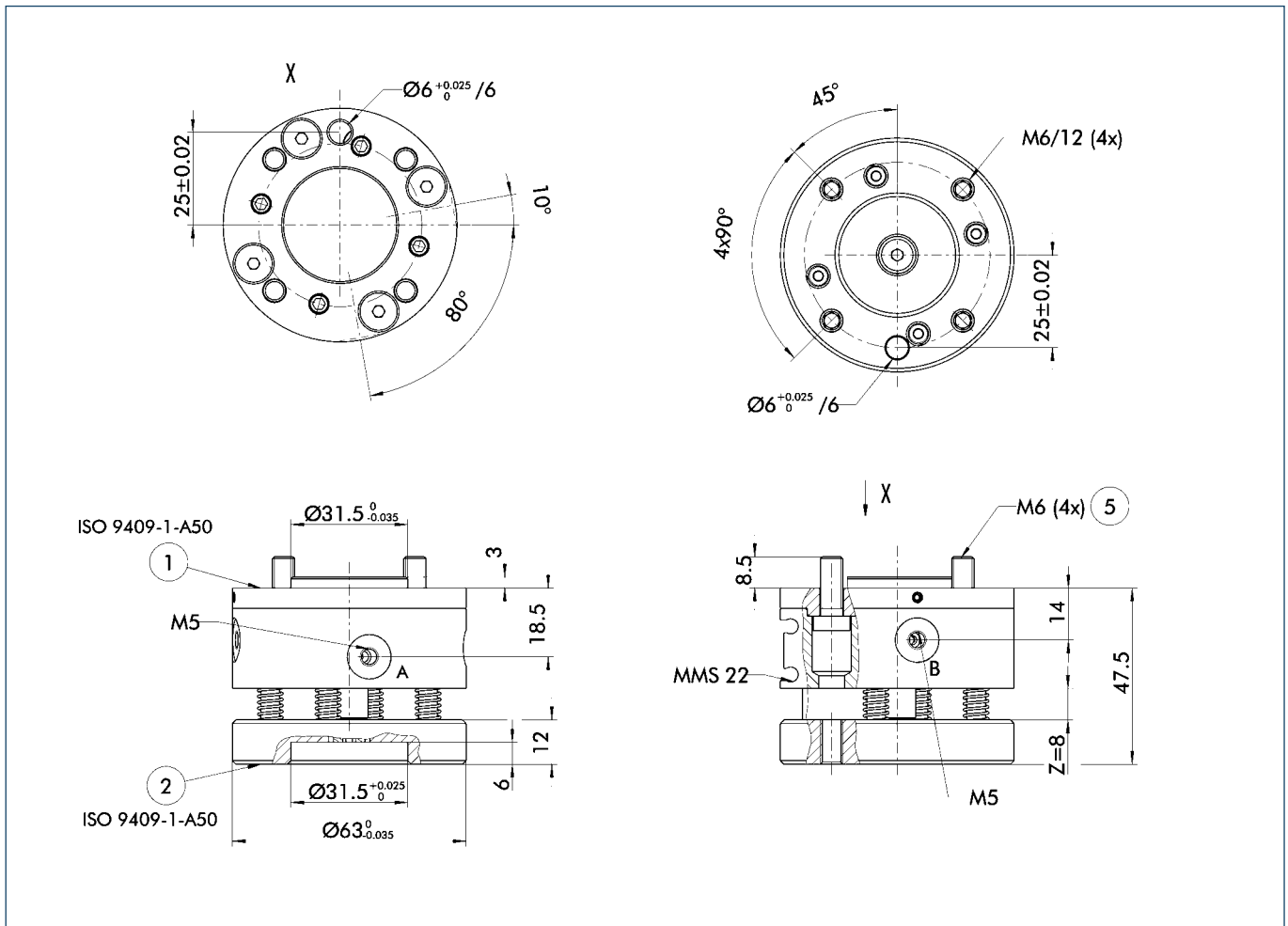

- A Connection locked
- B Air connection unlocked
- ① Connection, robot-side
- ② Connection, tool-side
- ⑤ Through-bores for screw connection with screw (enclosed)

Sensor system

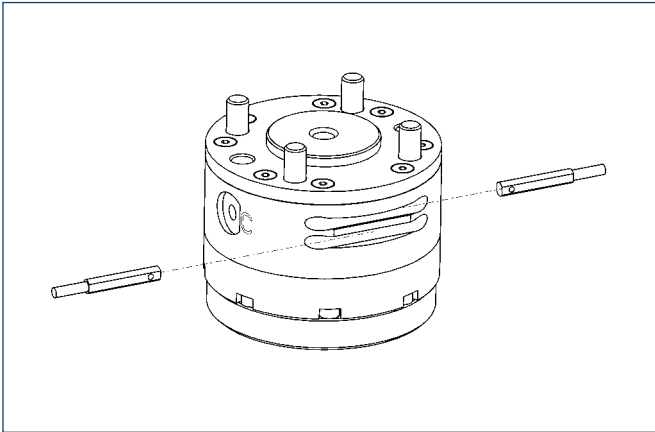

End position monitoring:

Electronic magnetic switches, for mounting in C-slot

Designation	ID	Recommended product
MMS 22-S-M5-NPN	0301439	
MMS 22-S-M5-NPN-SA	0301449	
MMS 22-S-M5-PNP	0301438	
MMS 22-S-M5-PNP-SA	0301448	
MMS 22-S-M8-NPN	0301433	
MMS 22-S-M8-NPN-SA	0301443	
MMS 22-S-M8-PNP	0301432	•
MMS 22-S-M8-PNP-SA	0301442	
MMSK 22-S-NPN	0301435	
MMSK 22-S-PNP	0301434	

① Two sensors (closers/S) are required for each compensation unit, plus extension cables as an option.

Extension cable for proximity switches/magnetic switches

Designation	ID
GK 3-M8	0301622
GK 3-M5-PNP/NPN	0301652
KV 10-M12	0301596
KV 10-M8	0301496
KV 20-M12	0301597
KV 20-M8	0301497
KV 3-M12	0301595
KV 3-M8	0301495
W 3-M12	0301503
W 5-M12	0301507
W 3-M5-PNP/NPN	0301650
WK 3-M8	0301594
WK 3-M8 NPN	0301602
WK 5-M8	0301502
WK 5-M8 NPN	9641116

① Please note the minimum permitted bending radii for the sensor cables, which are generally 35 mm.



You can find more detailed information on, and individual parts for, the above-mentioned accessories in the "Accessories" catalog section.

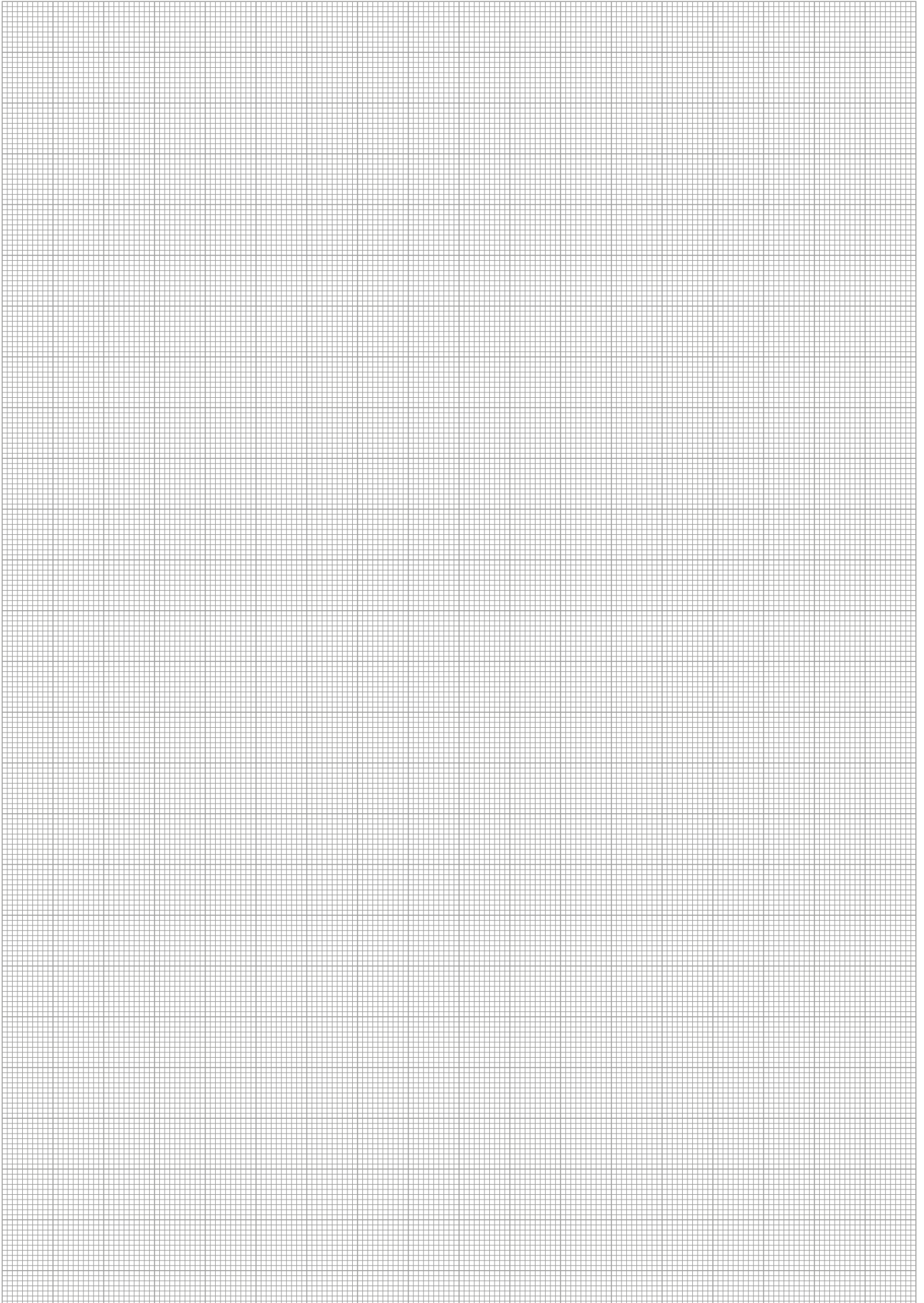



Load diagram

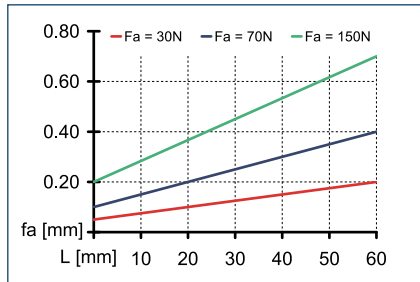
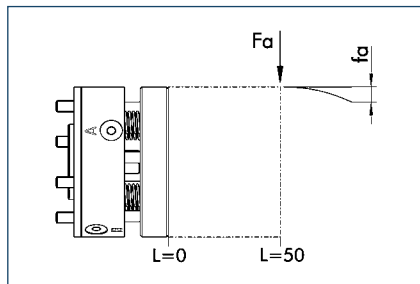

Deflection of the AGE-Z under load

Forces and moments

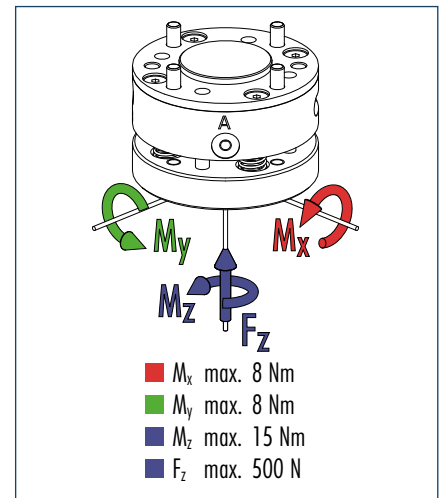

Technical data

Designation	AGE-Z-063	
	ID	032465
Workpiece weight (recommendation)	[kg]	6.0
Compensation stroke	[mm]	8.0
Mounting, round mechanical interface		ISO 9409-63-4-M6
Spring force	[N]	20-60
Extend piston force at 6 bar	[N]	560
Retract piston force at 6 bar	[N]	500
Weight	[kg]	0.6

Main views

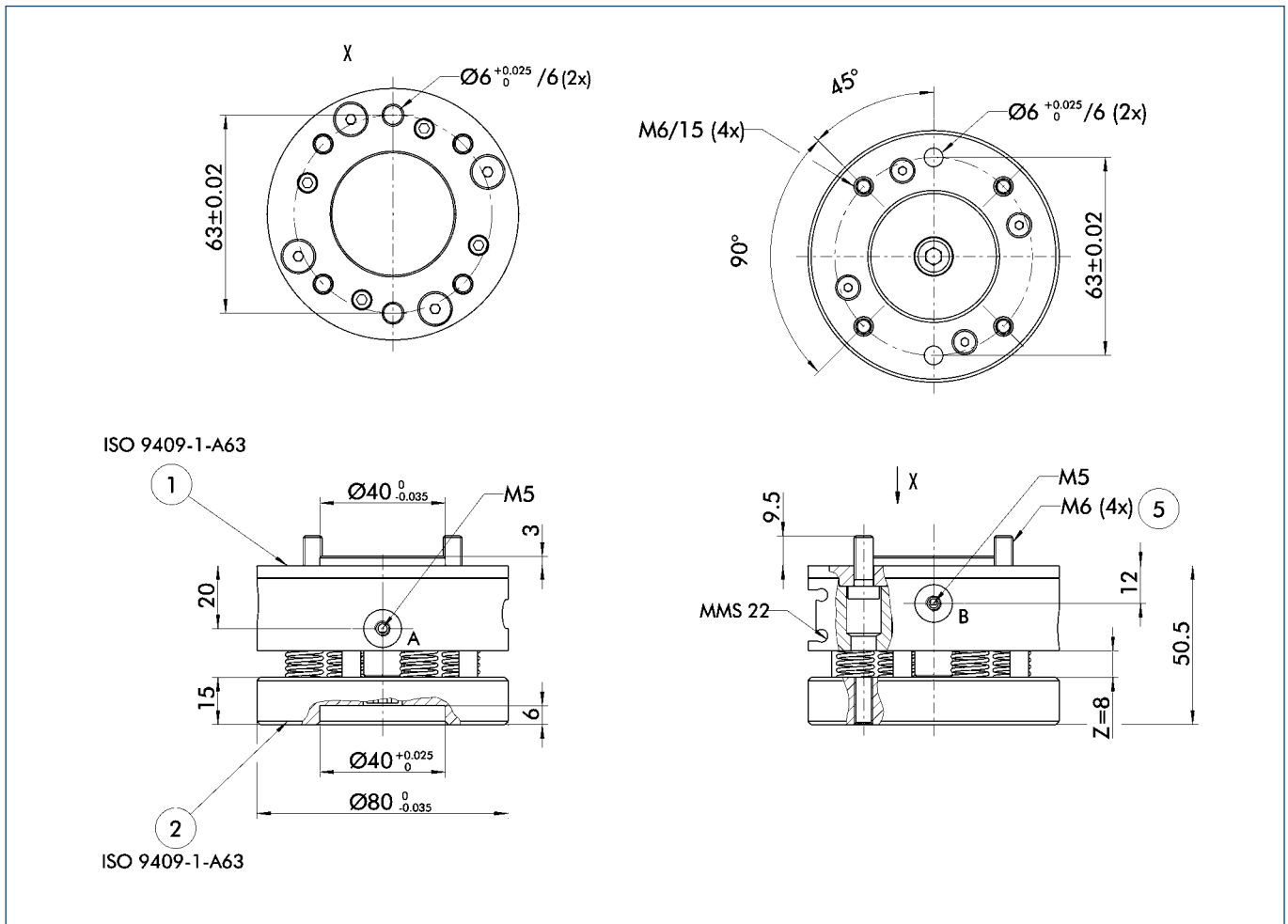

- A Locked air connection
- B Unlocked air connection
- ① Robot-side connection
- ② Tool-side connection
- ⑤ Through-bore for screw connection with screw (enclosed)

Sensor system

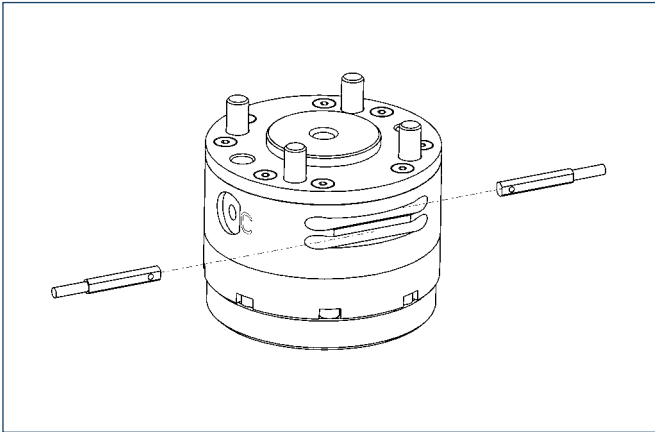

End position monitoring:

Electronic magnetic switches, for mounting in C-slot

Designation	ID	Recommended product
MMS 22-S-M5-NPN	0301439	
MMS 22-S-M5-NPN-SA	0301449	
MMS 22-S-M5-PNP	0301438	
MMS 22-S-M5-PNP-SA	0301448	
MMS 22-S-M8-NPN	0301433	
MMS 22-S-M8-NPN-SA	0301443	
MMS 22-S-M8-PNP	0301432	•
MMS 22-S-M8-PNP-SA	0301442	
MMSK 22-S-NPN	0301435	
MMSK 22-S-PNP	0301434	

① Two sensors (closers/S) are required for each compensation unit, plus extension cables as an option.

Extension cable for proximity switches/magnetic switches

Designation	ID
GK 3-M8	0301622
GK 3-M5-PNP/NPN	0301652
KV 10-M12	0301596
KV 10-M8	0301496
KV 20-M12	0301597
KV 20-M8	0301497
KV 3-M12	0301595
KV 3-M8	0301495
W 3-M12	0301503
W 5-M12	0301507
W 3-M5-PNP/NPN	0301650
WK 3-M8	0301594
WK 3-M8 NPN	0301602
WK 5-M8	0301502
WK 5-M8 NPN	9641116

① Please note the minimum permitted bending radii for the sensor cables, which are generally 35 mm.



For further information on individual elements of the accessories, please consult the "Accessories" section of the catalog.

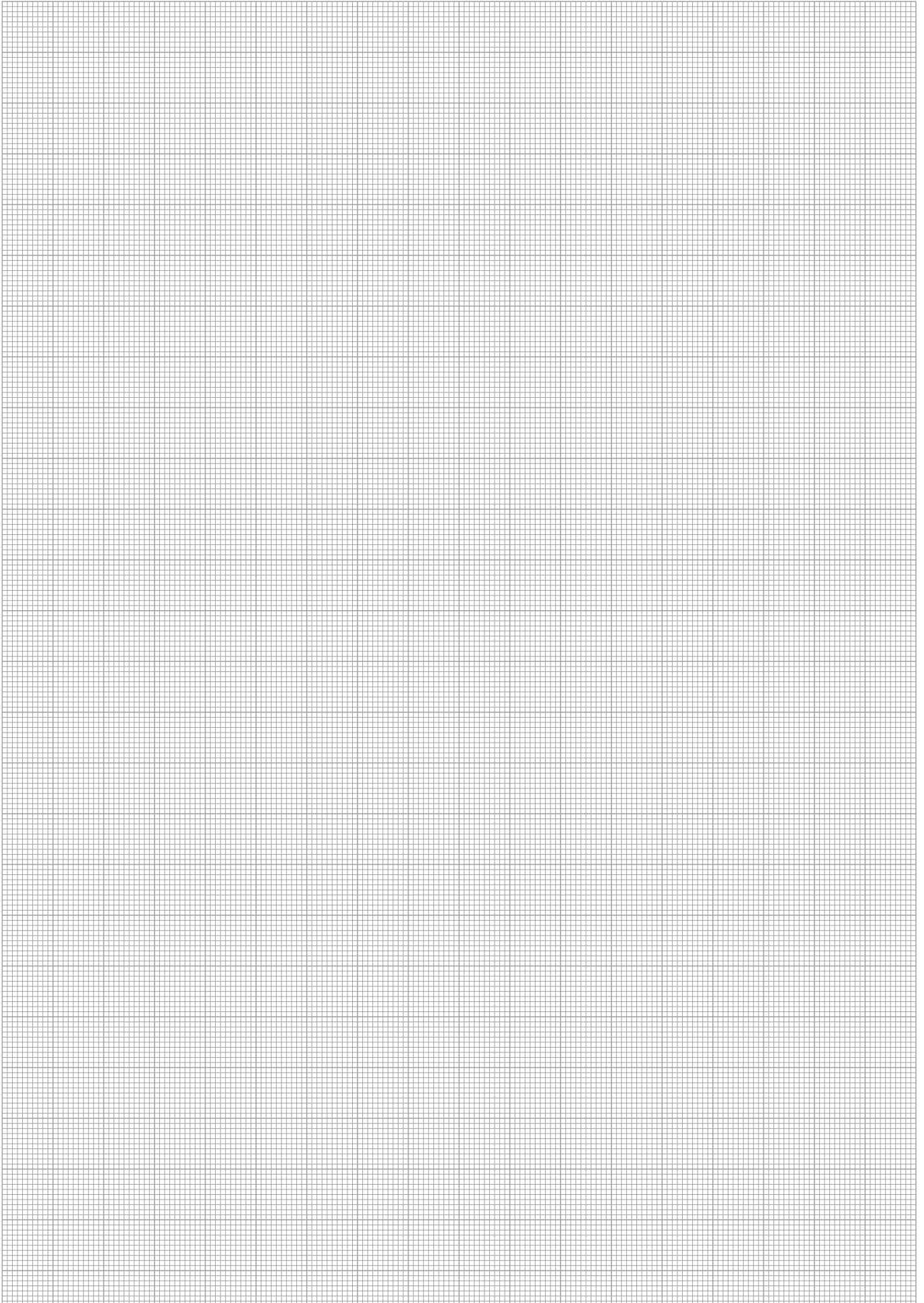



Load diagram

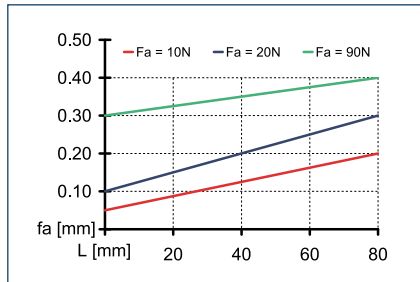
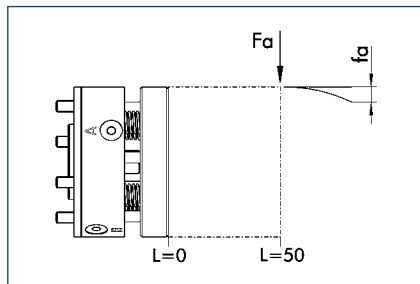

Deflection of the AGE-Z under load

Forces and moments

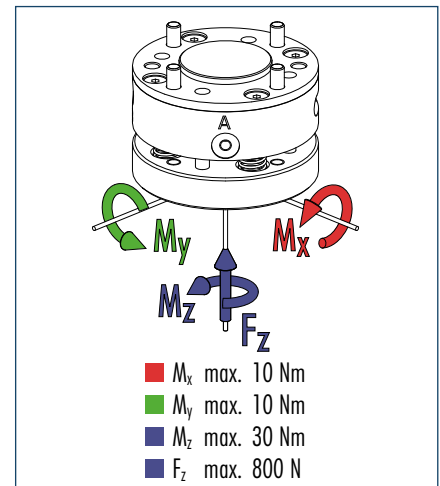

Technical data

Designation	AGE-Z-080	
	ID	0324482
Workpiece weight (recommendation)	[kg]	10.0
Compensation stroke	[mm]	8.0
Mounting, round mechanical interface		ISO 9409-80-6-M8
Spring force	[N]	40 - 240
Extend piston force at 6 bar	[N]	840
Retract piston force at 6 bar	[N]	600
Weight	[kg]	1.1

Sensor system

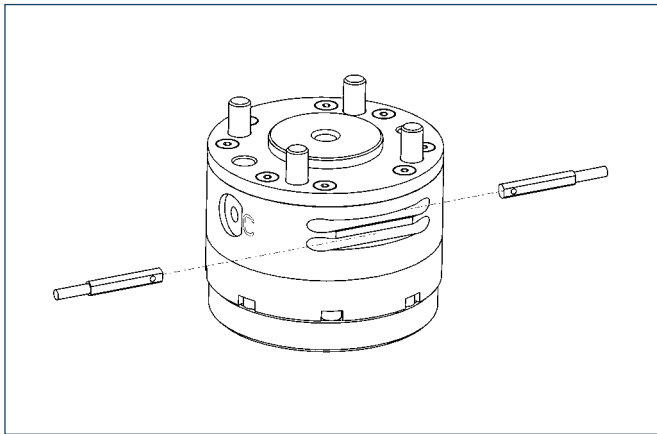

End position monitoring:

Electronic magnetic switches, for mounting in C-slot

Designation	ID	Recommended product
MMS 22-S-M5-NPN	0301439	
MMS 22-S-M5-NPN-SA	0301449	
MMS 22-S-M5-PNP	0301438	
MMS 22-S-M5-PNP-SA	0301448	
MMS 22-S-M8-NPN	0301433	
MMS 22-S-M8-NPN-SA	0301443	
MMS 22-S-M8-PNP	0301432	•
MMS 22-S-M8-PNP-SA	0301442	
MMSK 22-S-NPN	0301435	
MMSK 22-S-PNP	0301434	

① Two sensors (closers/S) are required for each compensation unit, plus extension cables as an option.

Extension cable for proximity switches/magnetic switches

Designation	ID
GK 3-M8	0301622
GK 3-M5-PNP/NPN	0301652
KV 10-M12	0301596
KV 10-M8	0301496
KV 20-M12	0301597
KV 20-M8	0301497
KV 3-M12	0301595
KV 3-M8	0301495
W 3-M12	0301503
W 5-M12	0301507
W 3-M5-PNP/NPN	0301650
WK 3-M8	0301594
WK 3-M8 NPN	0301602
WK 5-M8	0301502
WK 5-M8 NPN	9641116

① Please note the minimum permitted bending radii for the sensor cables, which are generally 35 mm.



You can find more detailed information on, and individual parts for, the above-mentioned accessories in the “Accessories” catalog section.

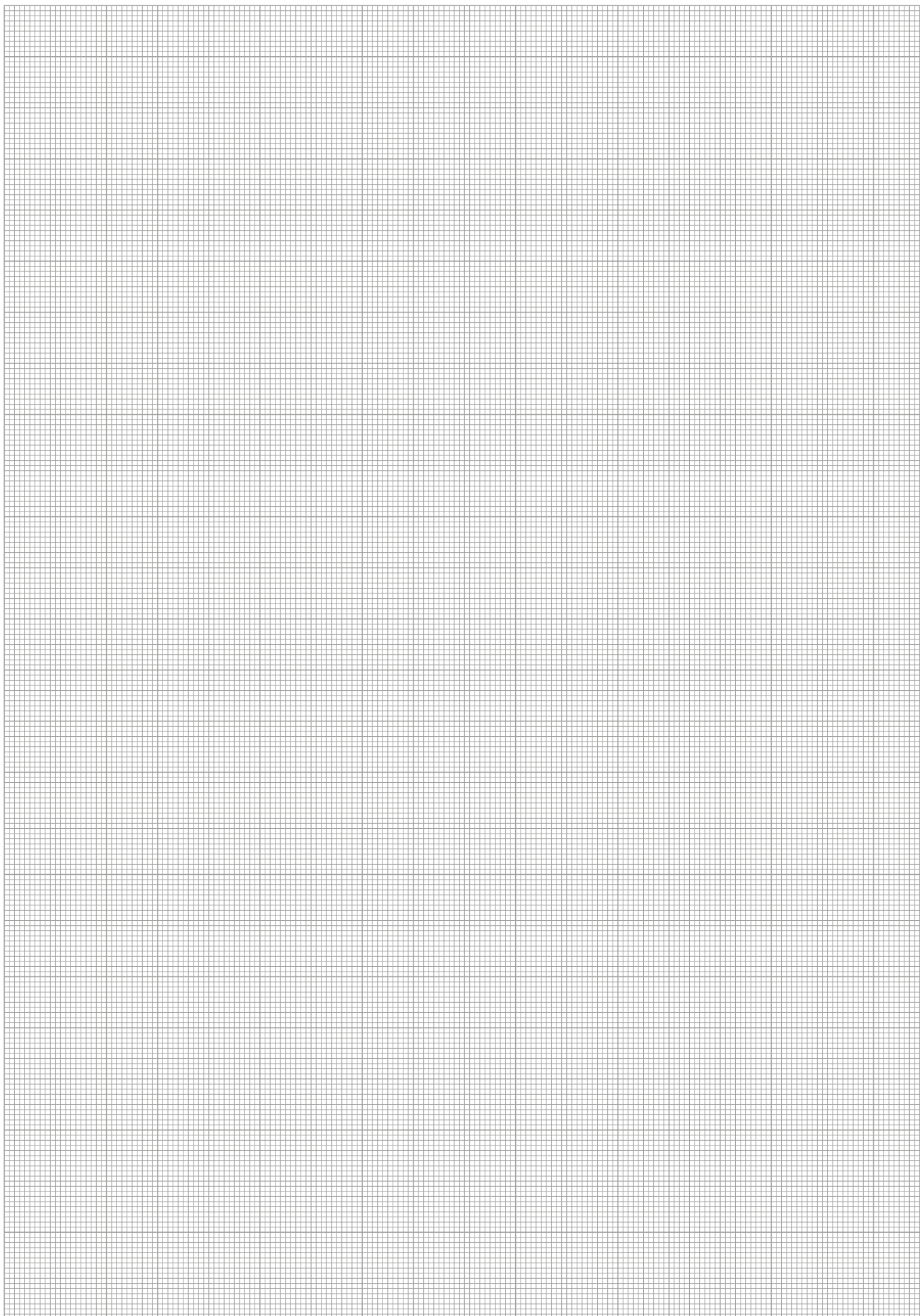



Sizes
050 .. 080



Workpiece weight
4 kg .. 10 kg



Compensation paths XY
 $\pm 2.5 \text{ mm} \dots \pm 4 \text{ mm}$



Rotation
 $\pm 12^\circ \dots \pm 16^\circ$

Application example



Insertion unit for assembling a pin in a bore, in an approximately tolerated position. The compensation unit compensates for the planar offset without allowing the workpiece to twist and therefore to tilt.

1 PGF 80 2-Finger Parallel Gripper with special fingers and workpiece (pin)

2 AGE-XY-80 Compensation Unit

Compensation Unit

Compensation unit for use in assembly, and for loading and unloading machines and tool carriers. Using the AGE-XY, workpieces can be gripped and routed reliably despite positioning or angle offset.

Area of application

Assembling, palletizing and inserting workpieces

Your advantages and benefits

ISO flange

for easy attachment to most types of robots without additional adapter plates

Robust guidance

for high moment load with minimum space requirements

Centric locking

for fixing the unit rigidly in a defined, centric position

Pneumatic position storage

for secure retention of the deflected position



General information on the series

Compensation paths and angles

± 2.5 mm to ± 4 mm

12° to 16°

Guides

Robust guidance

Actuation

Pneumatic, filtered compressed air (10 µm): dry, lubricated or non-lubricated

Operating pressure range

2 bar to 8 bar

Monitoring of central locking

Via electronic magnetic switch

Ambient temperature

5 °C to 60 °C

Material

The housing is made from a high-strength, hard-coated aluminum alloy. The functional components are made from hardened steel.

Warranty

24 months

Sectional diagram

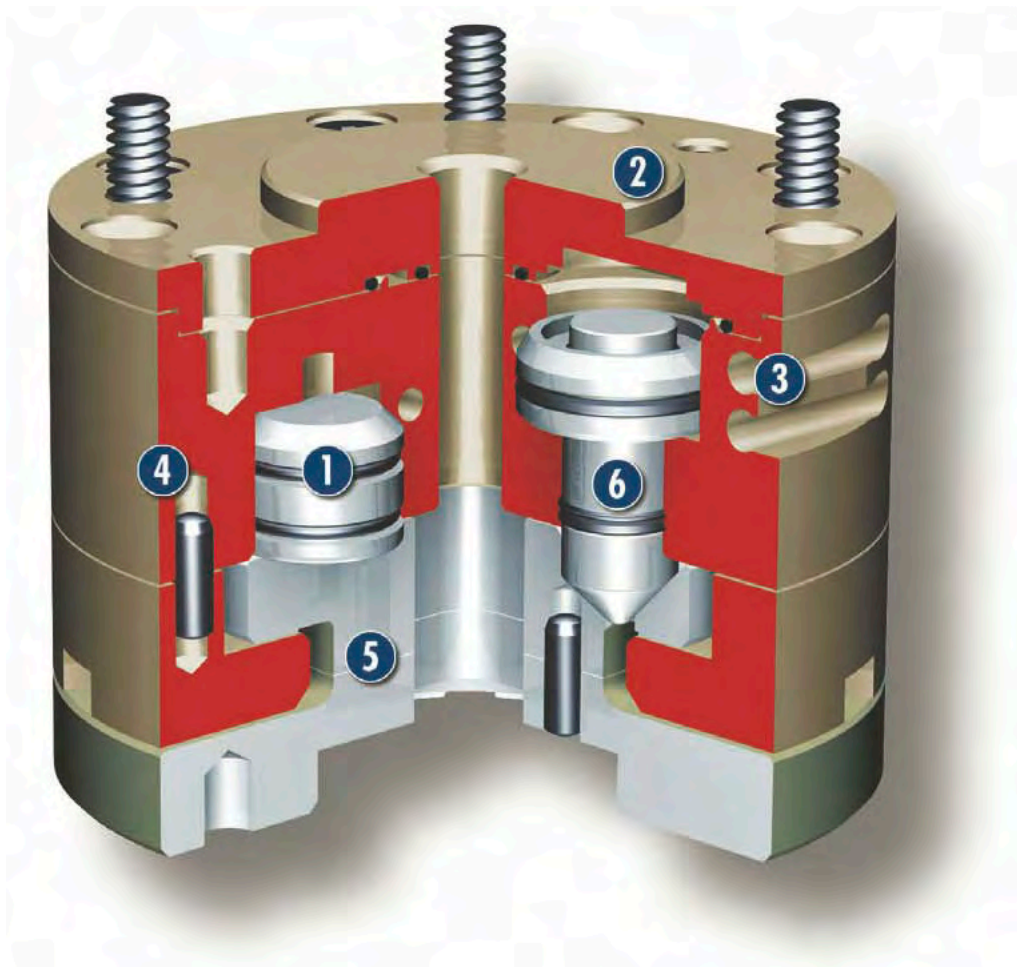

- 1 Position storage**
locking in any position via two pneumatically driven pistons and frictional contact
- 2 Direct mounting**
by means of standardized ISO 9409 interface for robots
- 3 Monitoring**
locking piston stroke monitoring with electronic magnetic switch
- 4 Housing**
weight-reduced through the use of a hard-anodized, high-strength aluminum alloy
- 5 Compensating element**
for compensating positioning errors in the X-Y plane
- 6 Locking mechanism**
pneumatically operated centric locking

Function description

The AGE compensation unit enables activation of the linear movement of robots/handling devices in the X and Y axis (AGE-X-Y), or additionally in the Z axis (AGE-X-Y-Z). This way, workpieces can be aligned centrally.

Accessories

Accessories from SCHUNK – the suitable supplement for maximum functionality, reliability and performance of all automation modules.

Fittings



MMS magnetic switches



Sensor cables



① For the exact size of the accessories, the availability for this size and the designation and ID, please refer to the additional views at the end of the size in question. You can find more detailed information on our accessory range in the “Accessories” catalog section.

General information on the series

Extreme ambient conditions

Please note that use in extreme ambient conditions (e.g. in the coolant zone, in the presence of abrasive dust) can significantly reduce the tool life of these units and we cannot accept any liability for this reduction. However, in many cases we have a solution at hand. Please ask for details.



Load diagram

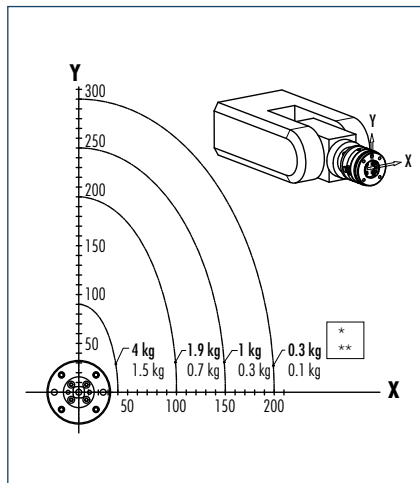

Position of the center of mass in relation to the payload in the event of horizontal configuration

* For centric locking

** For position storage

Forces and moments

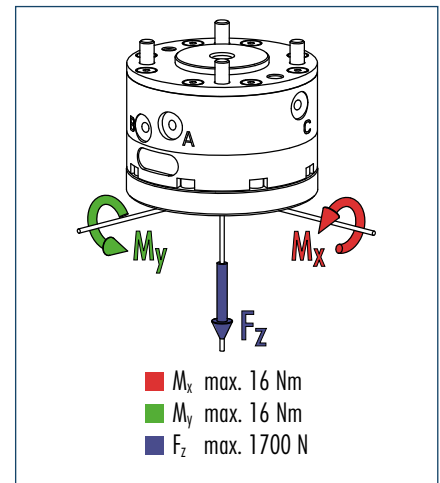

Technical data

Designation			AGE-XY-050	AGE-XY-050-P
	ID		0324450	0324451
Locking force at 6 bar	[N]		235	235
Position storage force at 6 bar	[N]		-	180
Compensation stroke	[mm]		± 2.5	± 2.5
Max. compensation angle (with AGE in centric position)	[°]		± 12	± 12
Workpiece weight (recommendation)	With centric locking	[kg]	4	4
	With deflected position storage	[kg]	-	1.5
Weight	[kg]		0.46	0.47
Max. rotation moment MR	With centric locking	[Nm]	3.5	3.5
	With deflected position storage	[Nm]	-	1.2
Max. load strength Fx, Fy	With centric locking	[N]	130	130
	With deflected position storage	[N]	-	45
Mass moment of inertia Iz	[kg/cm ²]		2.32	2.33
Robot and tool-side mounting			Interface ISO 9409-50-4-M6	Interface ISO 9409-50-4-M6
Maximum displacement force distance in z	[mm]		120	120

Main views

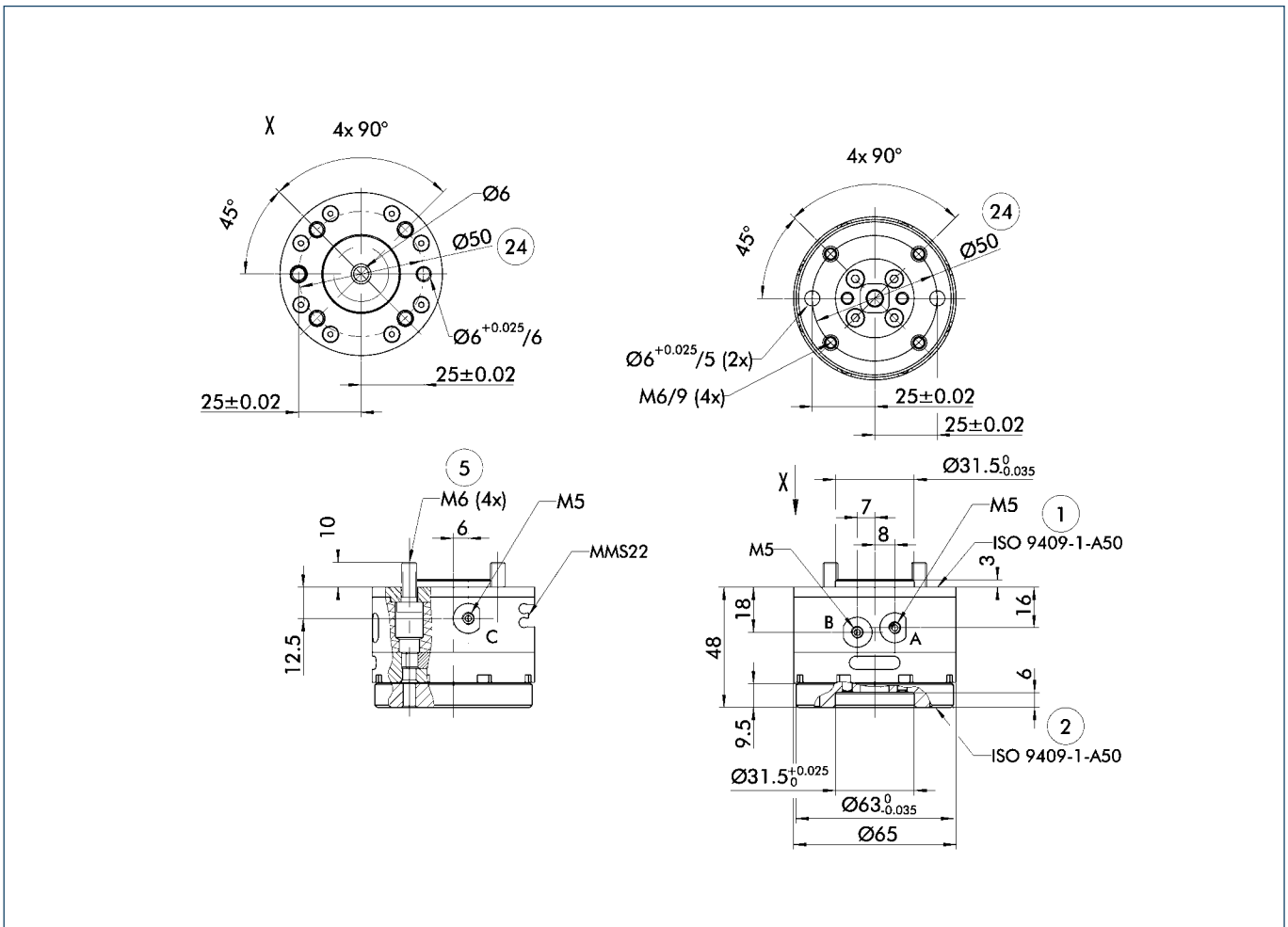

- A Unlocked air connection
- B Locked air connection
- C Air connection position storage XY
- ① Robot-side connection
- ② Tool-side connection
- ⑤ Through-bore for screw connection with screw (enclosed)
- Ø24 Bolt pitch circle

Diagram of the functions

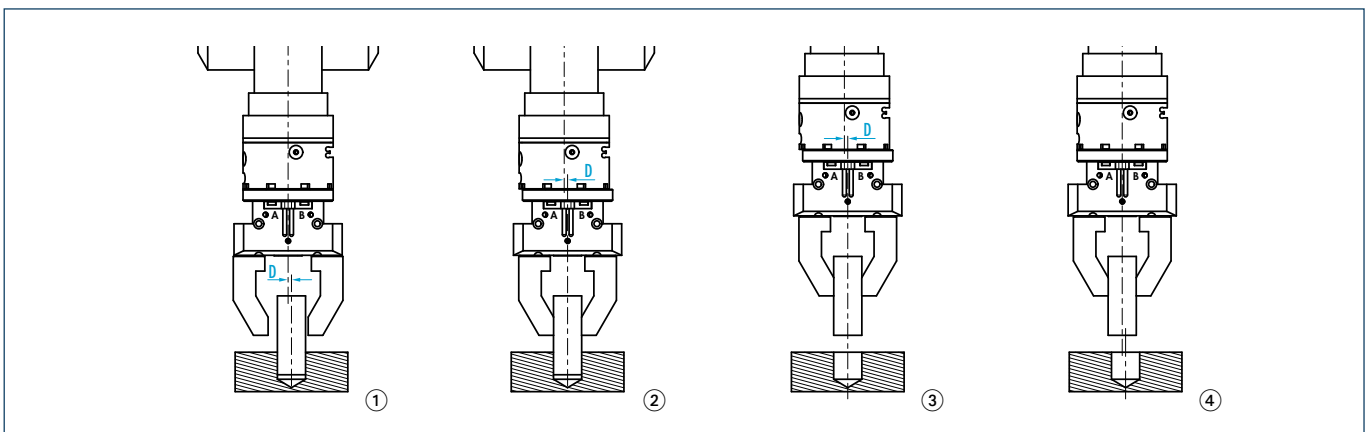

- ① Offset [D] between the gripper axis and the workpiece axis - AGE unlocked
- ② Gripper closes - AGE compensates for the offset [D] between the gripper and the workpiece. With the AGE-XY-P, this offset can be "stored".
- ③ Workpiece removed
- ④ Locking the AGE-workpiece axis, gripper axis and robot axis are centric in relation to one another

Sensor system

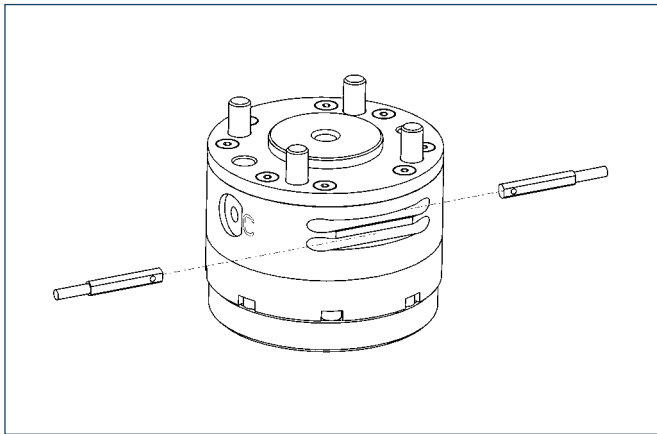

End position monitoring:

Electronic magnetic switches, for mounting in C-slot

Designation	ID	Recommended product
MMS 22-S-M5-NPN	0301439	
MMS 22-S-M5-NPN-SA	0301449	
MMS 22-S-M5-PNP	0301438	
MMS 22-S-M5-PNP-SA	0301448	
MMS 22-S-M8-NPN	0301433	
MMS 22-S-M8-NPN-SA	0301443	
MMS 22-S-M8-PNP	0301432	•
MMS 22-S-M8-PNP-SA	0301442	
MMSK 22-S-NPN	0301435	
MMSK 22-S-PNP	0301434	

① Two sensors (closers/S) are required for each compensation unit, plus extension cables as an option.

Extension cables for proximity switches/magnetic switches

Designation	ID
GK 3-M8	0301622
GK 3-M5-PNP/NPN	0301652
KV 10-M12	0301596
KV 10-M8	0301496
KV 20-M12	0301597
KV 20-M8	0301497
KV 3-M12	0301595
KV 3-M8	0301495
W 3-M12	0301503
W 5-M12	0301507
W 3-M5-PNP/NPN	0301650
WK 3-M8	0301594
WK 3-M8 NPN	0301602
WK 5-M8	0301502
WK 5-M8 NPN	9641116

① Please note the minimum permitted bending radii for the sensor cables, which are generally 35 mm.



You can find more detailed information on, and individual parts for, the above-mentioned accessories in the “Accessories” catalog section.

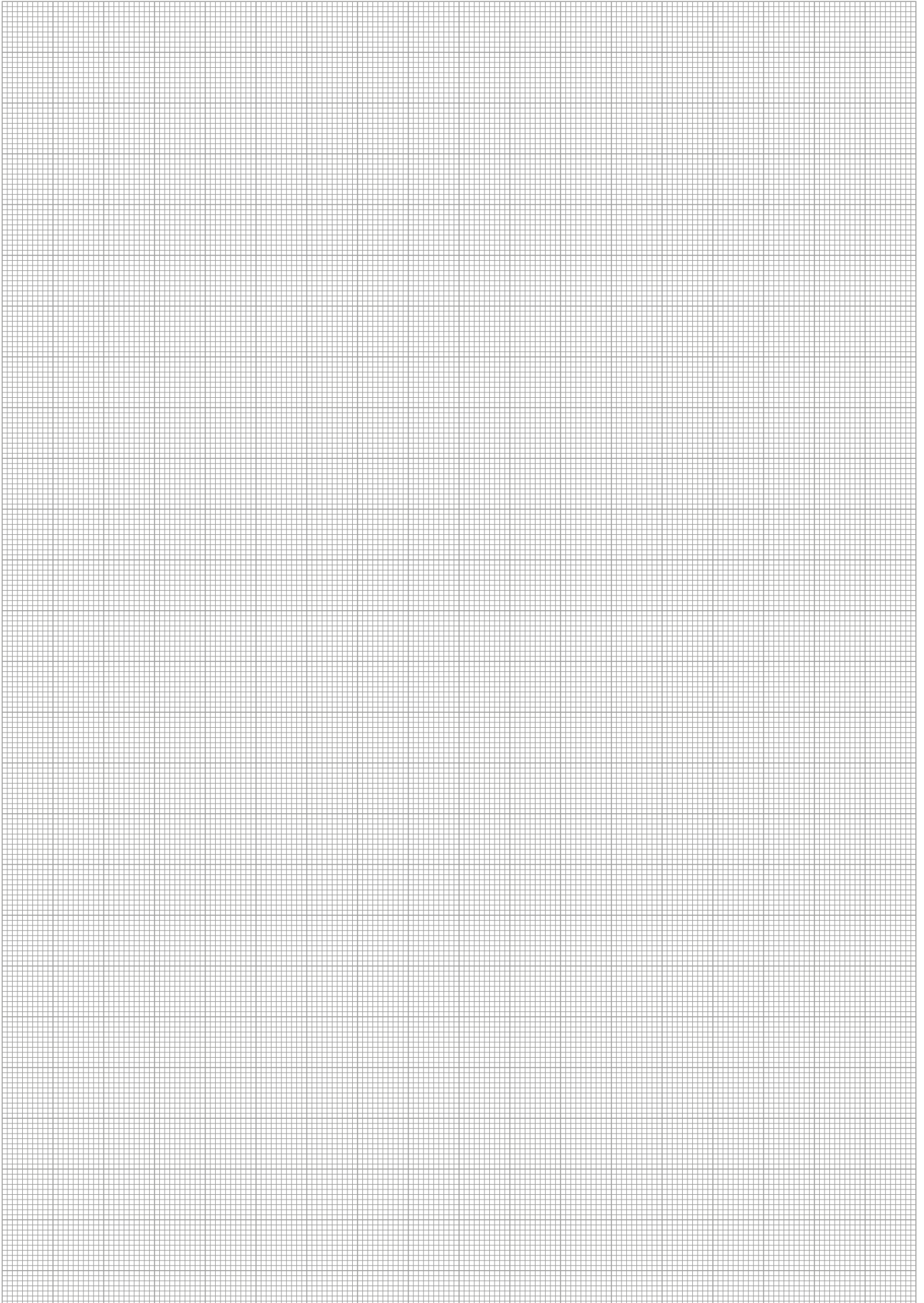

AGE-XY-063

Compensation · XY Compensation Units · Light Loads



Load diagram

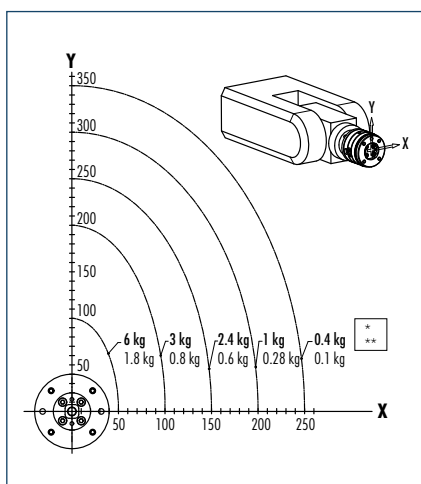

Position of the center of mass in relation to the payload in the event of horizontal configuration

* For centric locking

** For position storage

Forces and moments

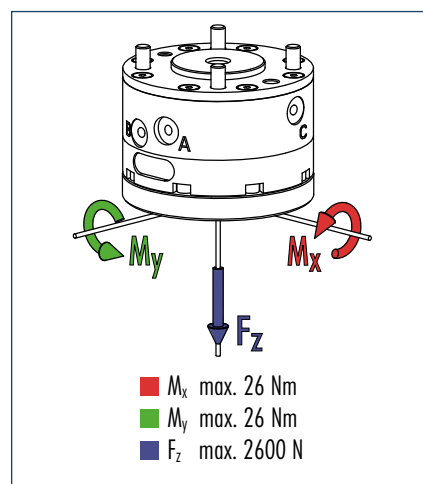

Technical data

Designation		AGE-XY-063	AGE-XY-063-P
	ID	0324463	0324464
Locking force at 6 bar	[N]	370	370
Position storage force at 6 bar	[N]	-	235
Compensation stroke	[mm]	± 3	± 3
Max. compensation angle (with AGE in centric position)	[°]	± 12	± 12
Workpiece weight	[kg]	6	6
(recommendation)	[kg]	-	1.8
Weight	[kg]	0.83	0.85
Max. rotation	[Nm]	6	6
moment MR	[Nm]	-	1.7
Max. load strength	[N]	200	200
Fx, Fy	[N]	-	50
Mass moment of inertia Iz	[kg/cm ²]	6.45	6.5
Robot and tool-side mounting		Interface ISO 9409-63-4-M6	Interface ISO 9409-63-4-M6
Maximum displacement force distance in z	[mm]	160	160

Main views

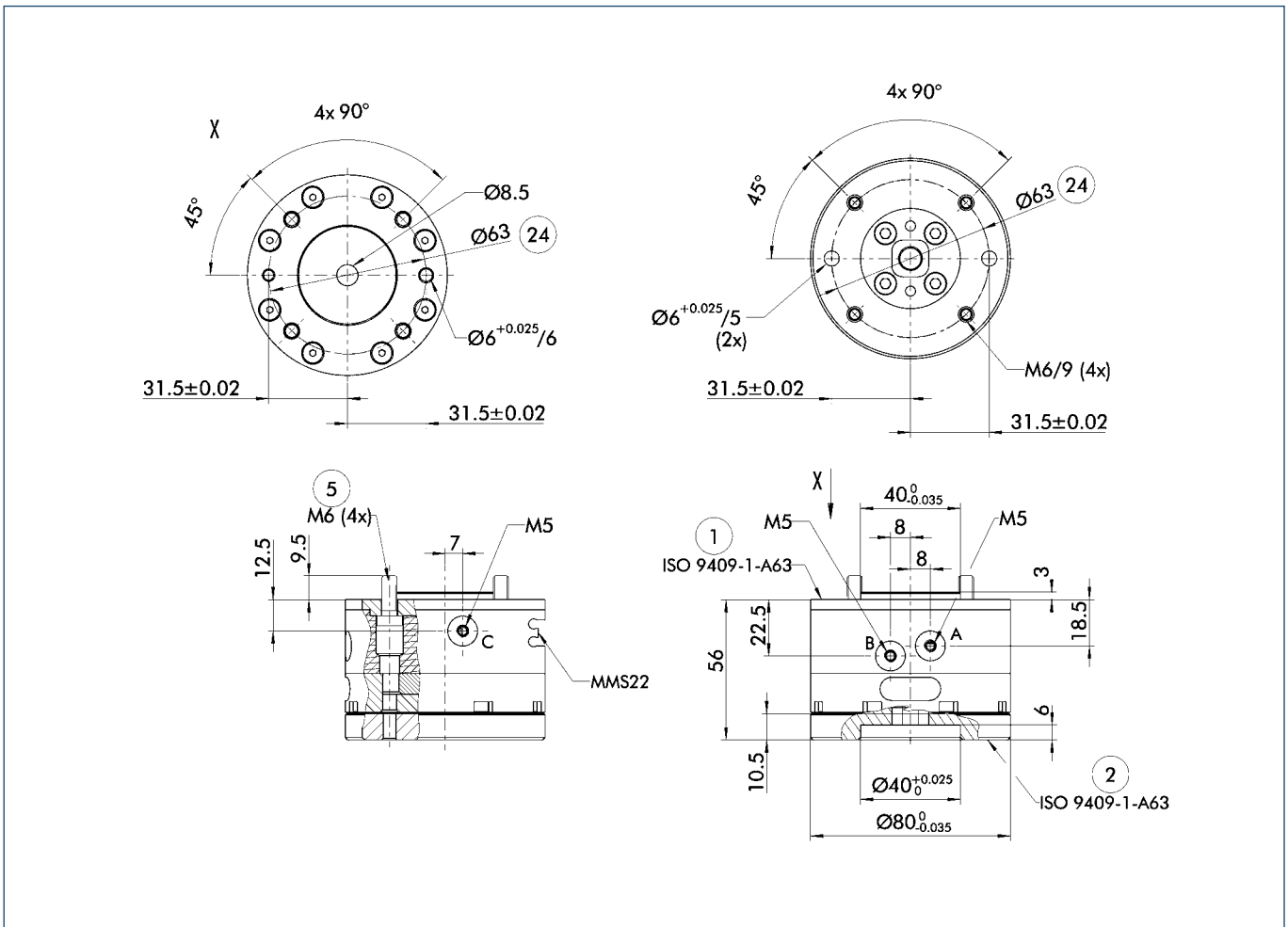

- A Unlocked air connection
- B Locked air connection
- C Air connection position storage XY
- ① Robot-side connection
- ② Tool-side connection
- ⑤ Through-bore for screw connection with screw (enclosed)
- ②④ Bolt pitch circle

Diagram of the functions

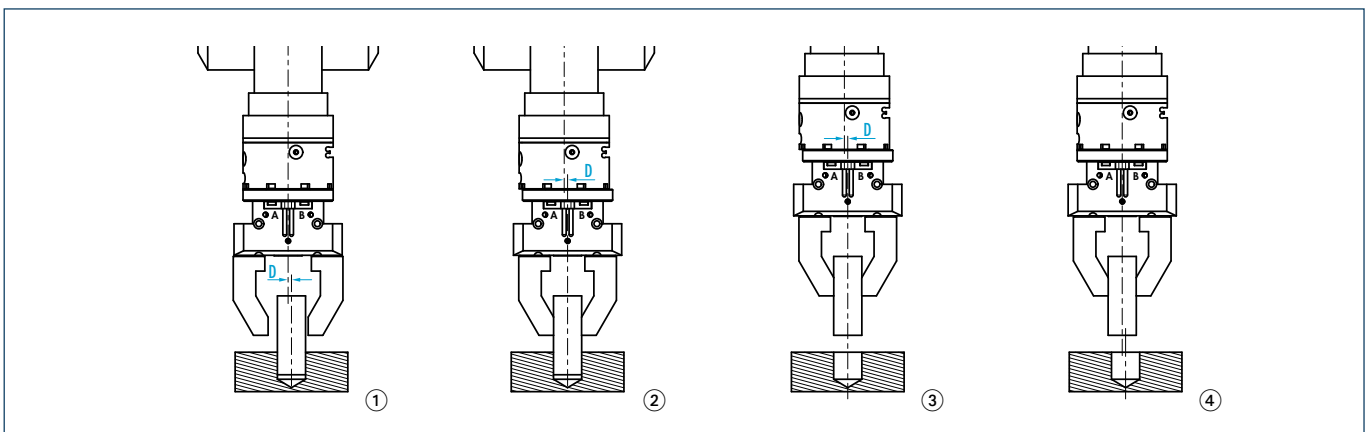

- ① Offset [D] between the gripper axis and the workpiece axis - AGE unlocked
- ② Gripper closes - AGE compensates for the offset [D] between the gripper and the workpiece. With the AGE-XY-P, this offset can be "stored".
- ③ Workpiece removed
- ④ Locking the AGE-workpiece axis, gripper axis and robot axis are centric in relation to one another

Sensor system

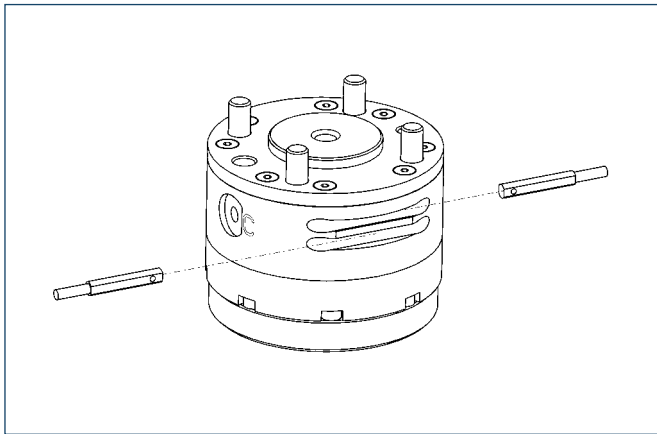

End position monitoring:

Electronic magnetic switches, for mounting in C-slot

Designation	ID	Recommended product
MMS 22-S-M5-NPN	0301439	
MMS 22-S-M5-NPN-SA	0301449	
MMS 22-S-M5-PNP	0301438	
MMS 22-S-M5-PNP-SA	0301448	
MMS 22-S-M8-NPN	0301433	
MMS 22-S-M8-NPN-SA	0301443	
MMS 22-S-M8-PNP	0301432	•
MMS 22-S-M8-PNP-SA	0301442	
MMSK 22-S-NPN	0301435	
MMSK 22-S-PNP	0301434	

① Two sensors (closers/S) are required for each compensation unit, plus extension cables as an option.

Extension cables for proximity switches/magnetic switches

Designation	ID
GK 3-M8	0301622
GK 3-M5-PNP/NPN	0301652
KV 10-M12	0301596
KV 10-M8	0301496
KV 20-M12	0301597
KV 20-M8	0301497
KV 3-M12	0301595
KV 3-M8	0301495
W 3-M12	0301503
W 5-M12	0301507
W 3-M5-PNP/NPN	0301650
WK 3-M8	0301594
WK 3-M8 NPN	0301602
WK 5-M8	0301502
WK 5-M8 NPN	9641116

① Please note the minimum permitted bending radii for the sensor cables, which are generally 35 mm.



You can find more detailed information on, and individual parts for, the above-mentioned accessories in the “Accessories” catalog section.

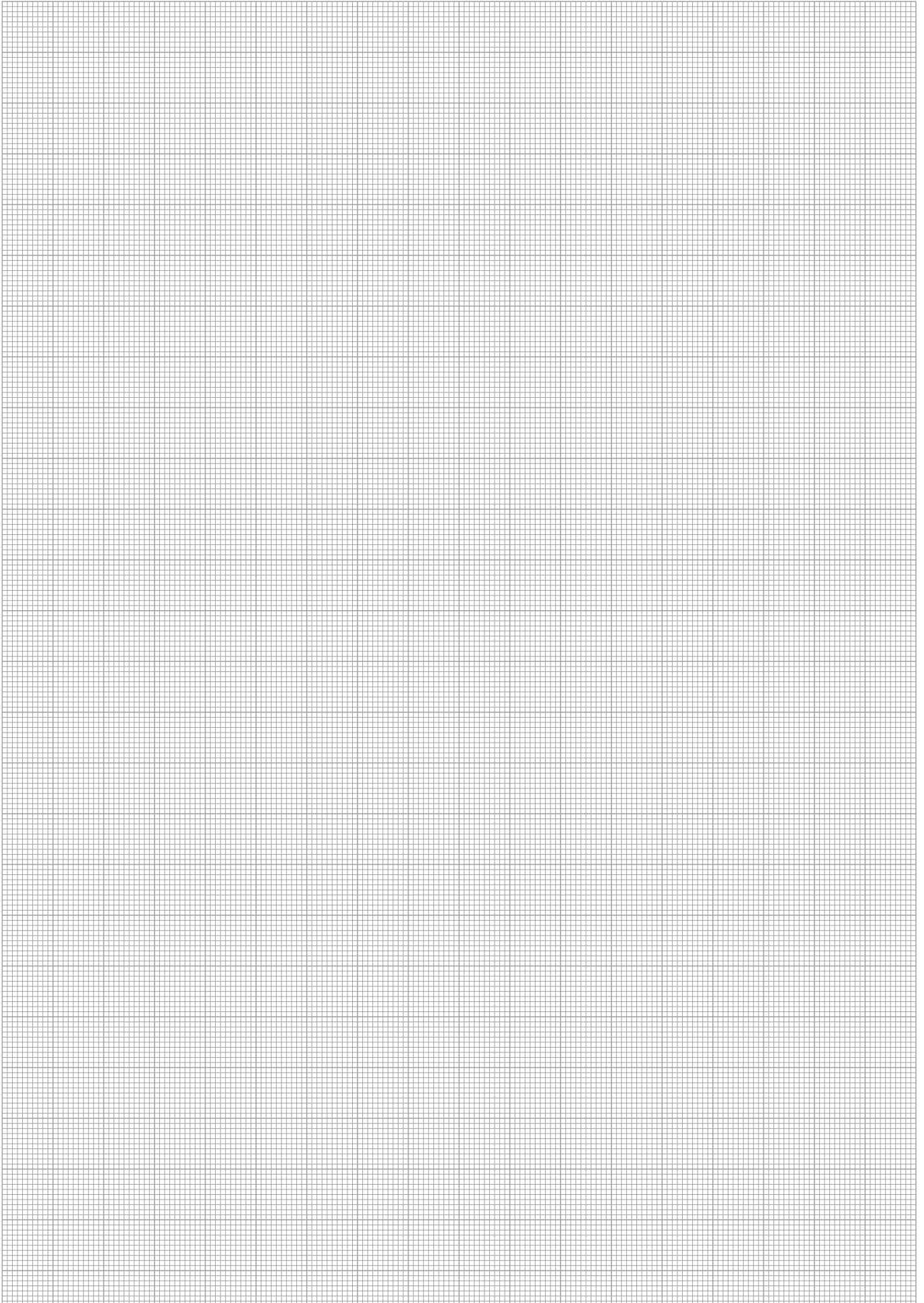



Load diagram

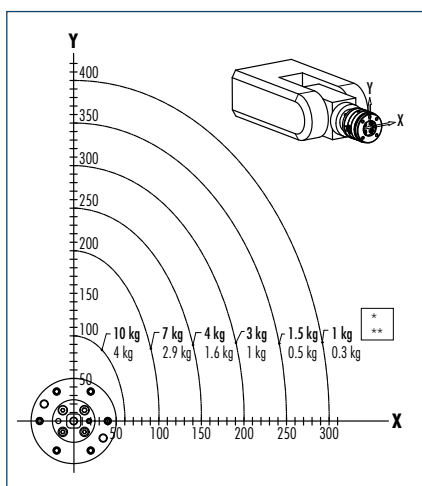

Position of the center of mass in relation to the payload in the event of horizontal configuration

* For centric locking

** For position storage

Forces and moments

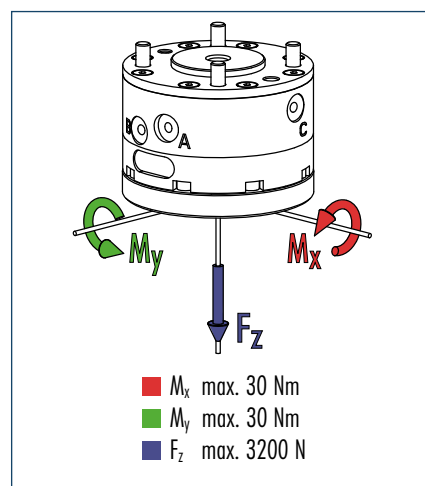

Technical data

Designation		AGE-XY-080	AGE-XY-080-P
	ID	0324480	0324481
Locking force at 6 bar	[N]	580	580
Position storage force at 6 bar	[N]	-	580
Compensation stroke	[mm]	± 4	± 4
Max. compensation angle (with AGE in centric position)	[°]	± 16	± 16
Workpiece weight (recommendation)	With centric locking	10	10
	With deflected position storage	-	4
Weight	[kg]	1.49	1.5
Max. rotation moment MR	With centric locking	9	9
	With deflected position storage	-	4
Max. load strength	[N]	310	310
F_x, F_y	[N]	-	145
Mass moment of inertia I_z	[kg/cm ²]	17.8	18.0
Robot and tool-side mounting		Interface ISO 9409-80-6-M8	Interface ISO 9409-80-6-M8
Maximum displacement force distance in z	[mm]	200	200

Main views

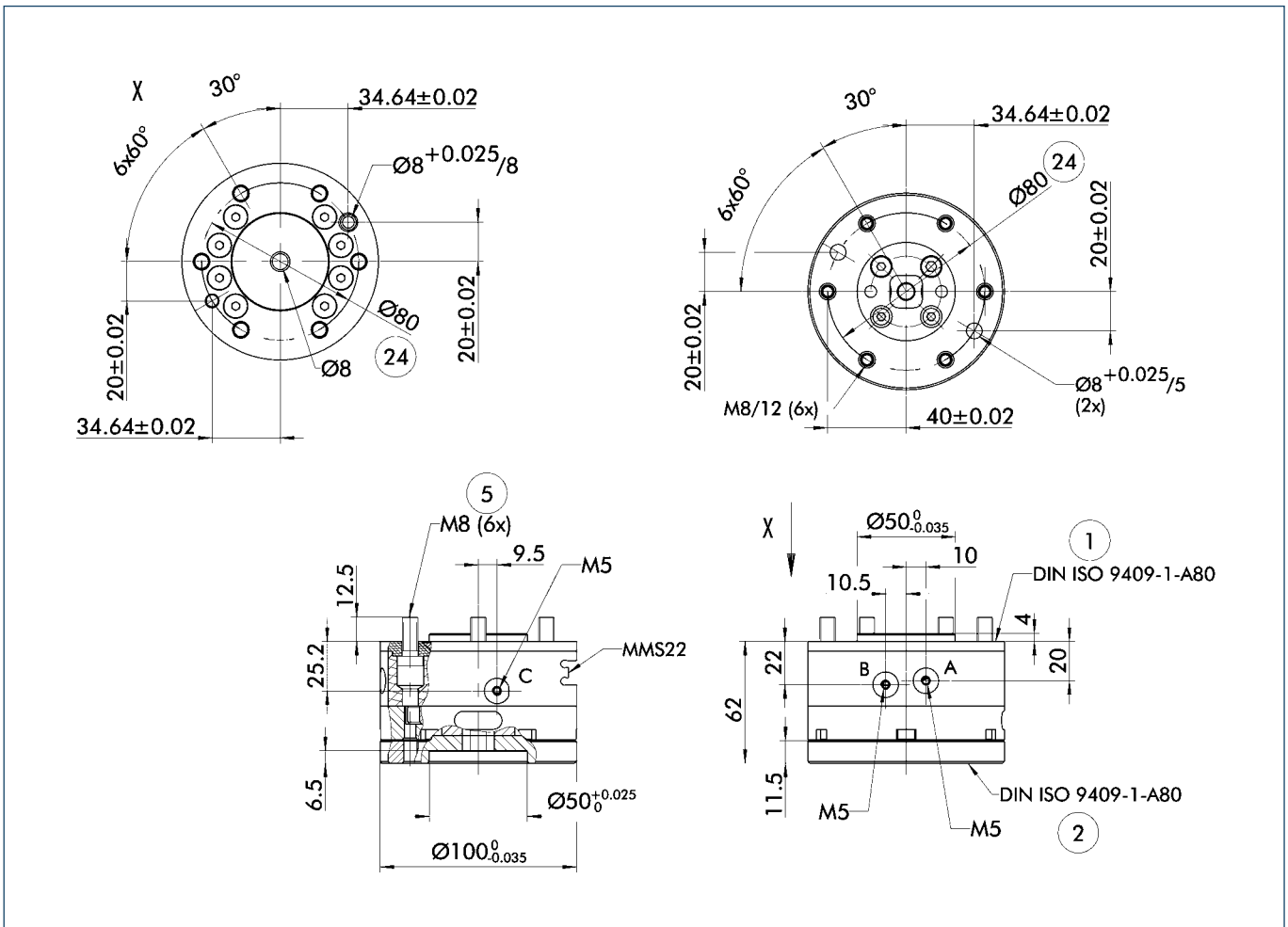

- A Unlocked air connection
- B Locked air connection
- C Air connection position storage XY
- ① Robot-side connection
- ② Tool-side connection
- ⑤ Through-bore for screw connection with screw (enclosed)
- ②④ Bolt pitch circle

Diagram of the functions

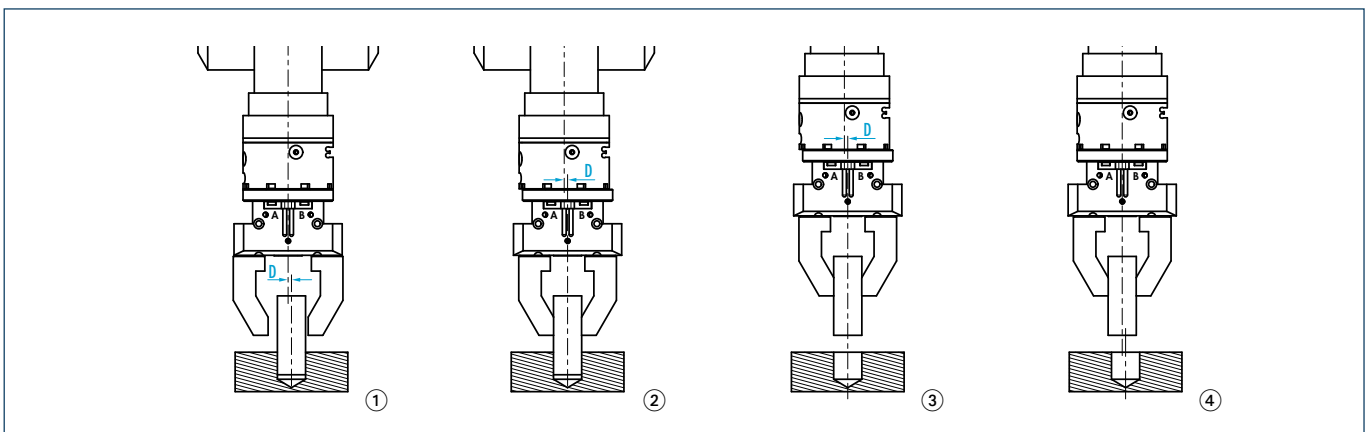

- ① Offset [D] between the gripper axis and the workpiece axis - AGE unlocked
- ② Gripper closes - AGE compensates for the offset [D] between the gripper and the workpiece. With the AGE-XY-P, this offset can be "stored".
- ③ Workpiece removed
- ④ Locking the AGE-workpiece axis, gripper axis and robot axis are centric in relation to one another

Sensor system

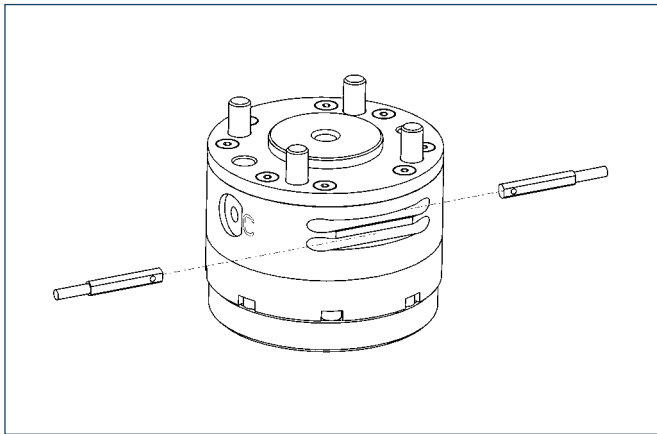

End position monitoring:

Electronic magnetic switches, for mounting in C-slot

Designation	ID	Recommended product
MMS 22-S-M5-NPN	0301439	
MMS 22-S-M5-NPN-SA	0301449	
MMS 22-S-M5-PNP	0301438	
MMS 22-S-M5-PNP-SA	0301448	
MMS 22-S-M8-NPN	0301433	
MMS 22-S-M8-NPN-SA	0301443	
MMS 22-S-M8-PNP	0301432	•
MMS 22-S-M8-PNP-SA	0301442	
MMSK 22-S-NPN	0301435	
MMSK 22-S-PNP	0301434	

① Two sensors (closers/S) are required for each compensation unit, plus extension cables as an option.

Extension cables for proximity switches/magnetic switches

Designation	ID
GK 3-M8	0301622
GK 3-M5-PNP/NPN	0301652
KV 10-M12	0301596
KV 10-M8	0301496
KV 20-M12	0301597
KV 20-M8	0301497
KV 3-M12	0301595
KV 3-M8	0301495
W 3-M12	0301503
W 5-M12	0301507
W 3-M5-PNP/NPN	0301650
WK 3-M8	0301594
WK 3-M8 NPN	0301602
WK 5-M8	0301502
WK 5-M8 NPN	9641116

① Please note the minimum permitted bending radii for the sensor cables, which are generally 35 mm.



You can find more detailed information on, and individual parts for, the above-mentioned accessories in the “Accessories” catalog section.

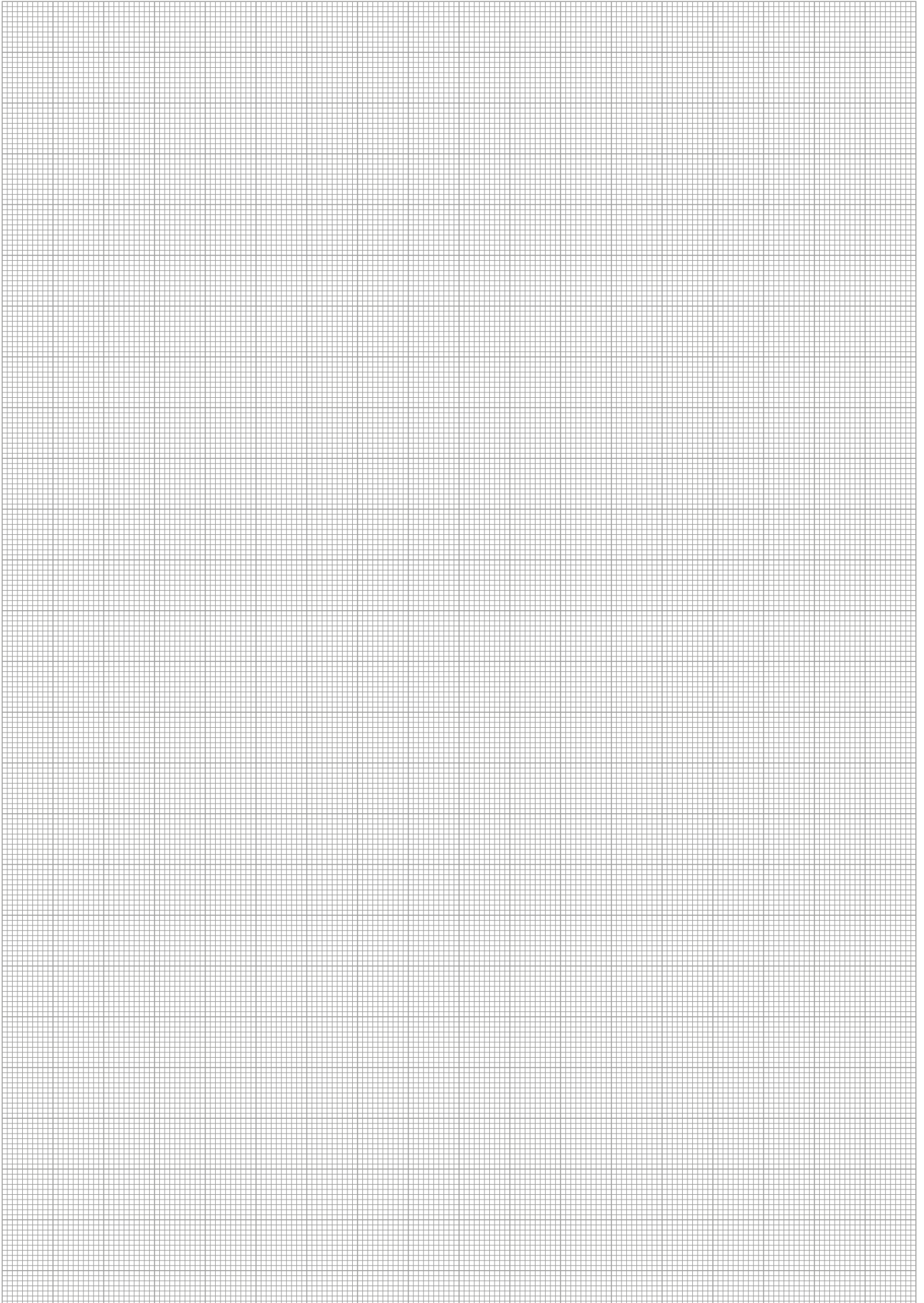



Sizes
031 .. 080



Workpiece weight
1.5 kg .. 32 kg



Compensation paths XY
 $\pm 1.5 \text{ mm} \dots \pm 5 \text{ mm}$

Application example



Insertion unit for assembling a pin in a bore, in an approximately tolerated position. The compensation unit compensates for the planar offset without allowing the workpiece to twist and therefore to tilt.

1 PGF 80 2-Finger Parallel Gripper with special fingers and workpiece (pin)

2 AGE-F-80 Compensation Unit

Compensation Unit with spring return

Compensation unit for use in assembly, and for loading and unloading machines and tool carriers. Using the AGE-F, workpieces can be gripped and routed reliably despite positioning offset

Area of application

Assembling, palletizing and inserting workpieces

Your advantages and benefits

Spring return in 3 levels

Defined centric Position with a repeat accuracy of 0.003 mm

Direct mounting of Parallel- and Centric Grippers

Possibility to mount PGN-plus and PZN-plus on the AGE-F without additional adapter plate

Roller bearing guide

Smooth-running compensation even with small application force



General information on the series

Compensation paths and angles

± 1.5 mm bis ± 5 mm

Guides

Roller bearing guide

Actuation

Spring return with spring stiffness from 1 N to 47 N

Monitoring of the compensation path

Via electronic magnetic switch

Ambient temperature

5 °C to 60 °C

Material

The housing is made from a high-strength, hard-coated aluminum alloy. The functional components are made from hardened steel.

Warranty

24 months

Sectional diagram

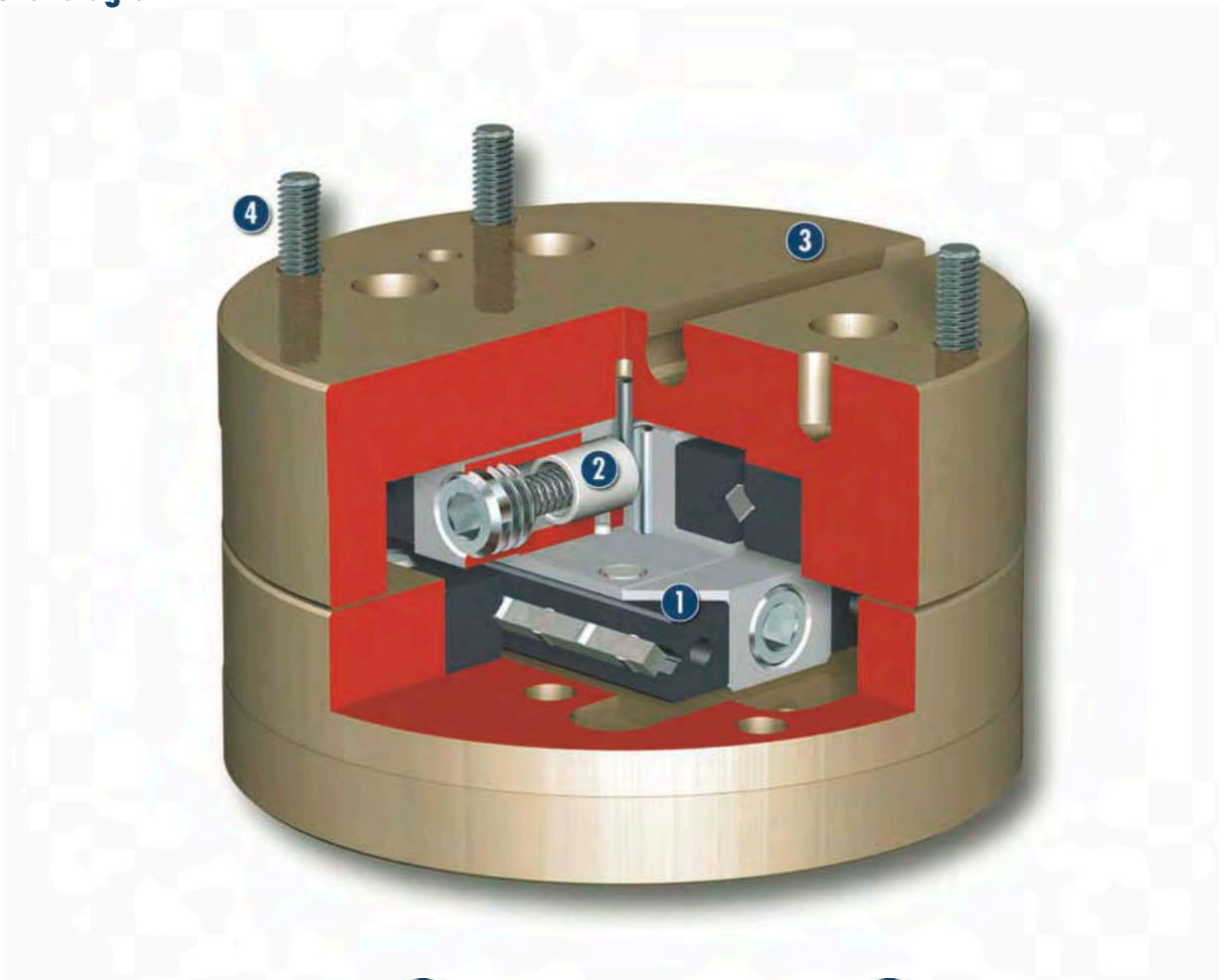

- 1 Linear Guides**
Smooth-running roller bearing
 - 3 Groove for Magnetic Switch**
For monitoring the movement in X and Y direction
 - 4 Housing**
Weight-reduced through the use of a hardanodized, high-strength aluminum alloy
- 2 Spring Loaded Reset Piston**
Springs with different stiffness for centric reset without pneumatic

Diagram of the functions

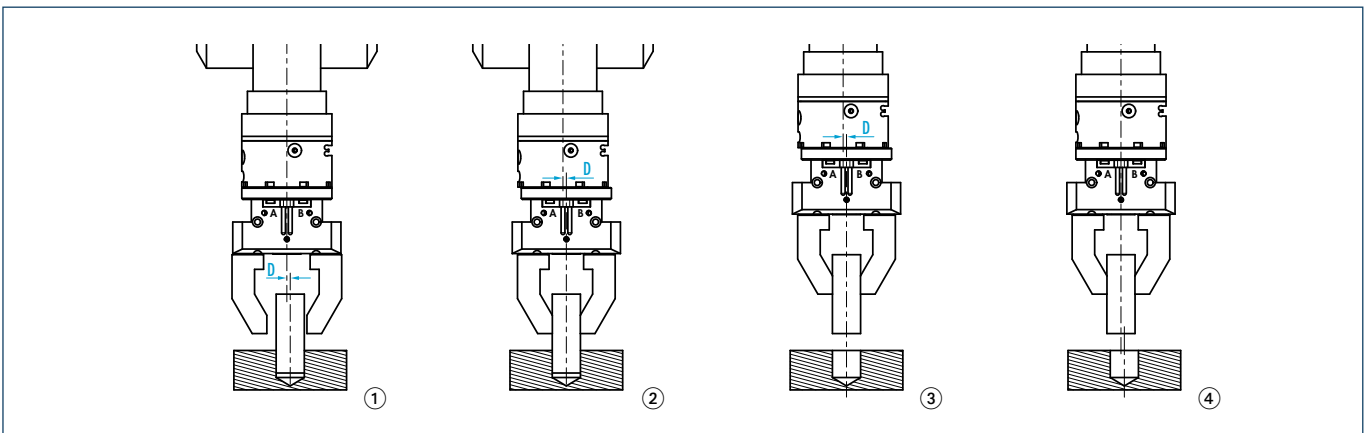

- ① Offset [D] between the gripper axis and the workpiece axis - AGE unlocked
- ② Gripper closes - AGE compensates for the offset [D] between the gripper and the workpiece. With the AGE-XY-P, this offset can be "stored".
- ③ Workpiece removed
- ④ Locking the AGE-workpiece axis, gripper axis and robot axis are centric in relation to one another

Accessories

Accessories from SCHUNK – the suitable supplement for maximum functionality, reliability and performance of all automation modules.

Fittings



MMS magnetic switches



Sensor cables



① For the exact size of the accessories, the availability for this size and the designation and ID, please refer to the additional views at the end of the size in question. You can find more detailed information on our accessory range in the “Accessories” catalog section.

General information on the series

Extreme ambient conditions

Please note that use in extreme ambient conditions (e.g. in the coolant zone, in the presence of abrasive dust) can significantly reduce the tool life of these units and we cannot accept any liability for this reduction. However, in many cases we have a solution at hand. Please ask for details.

AGE-F-031

Compensation · XY Compensation Units · Compensation Unit with Spring Return

Forces and moments

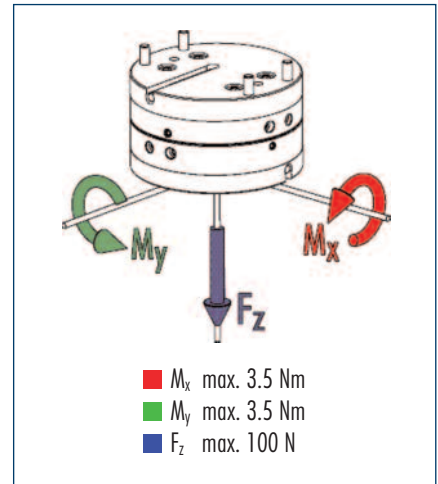

Technical data

Designation		AGE-F-XY-031-1	AGE-F-XY-031-2	AGE-F-XY-031-3
	ID	0324900	0324901	0324902
Compensation stroke X	[mm]	± 1.5	± 1.5	± 1.5
Compensation stroke Y	[mm]	± 1.5	± 1.5	± 1.5
Workpiece weight recommendation	[kg]	1.5	1.5	1.5
Max. payload F_z	[N]	100	100	100
Max. payload F_d	[N]	200	200	200
Weight	[kg]	0.123	0.123	0.123
Moment M_x M_y	[Nm]	3.5	3.5	3.5
Moment M_z	[Nm]	6.0	6.0	6.0
Mass Moment of inertia I_z	[kg/cm ²]	0.3	0.3	0.3
Mounting robot side		ISO 9409-31.5-4-M5 with adapter plate (optional)		
Mounting tool side		PGN-plus/PZN-plus 40		
Repeat accuracy	[mm]	± 0.003	± 0.003	± 0.003
Spring force	[N]	1.0	2.5	3.3
Spring rate	[N/mm]	0.6	0.8	1.9
Min. ambient temperature	[°C]	5.0	5.0	5.0
Max. ambient temperature	[°C]	80	80	80

Main views

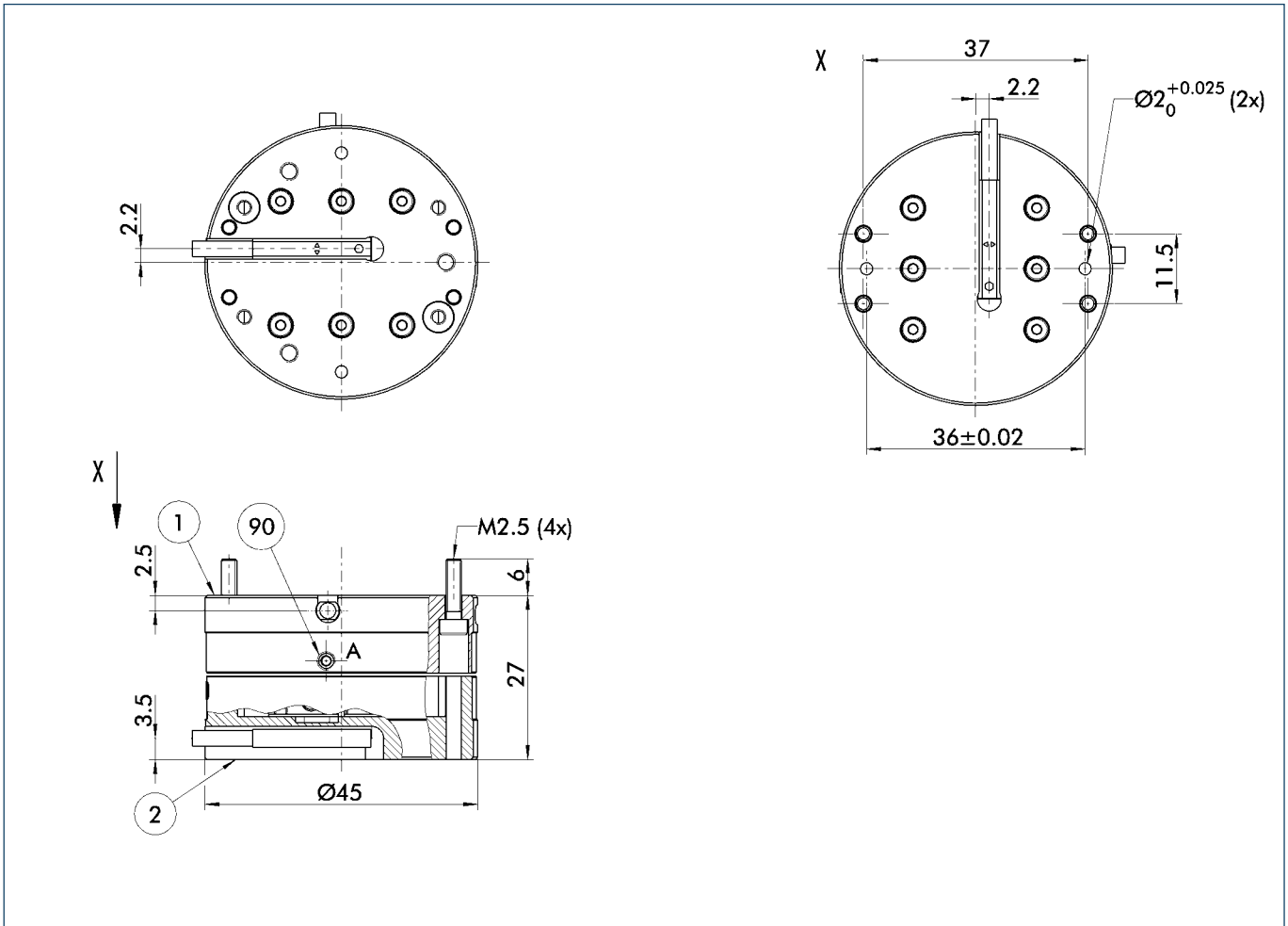

- ① Robot-side connection
- ② Tool-side connection
- ⑨ Adjustable stop for stroke limitation

Mounting pattern for PGN-plus 40

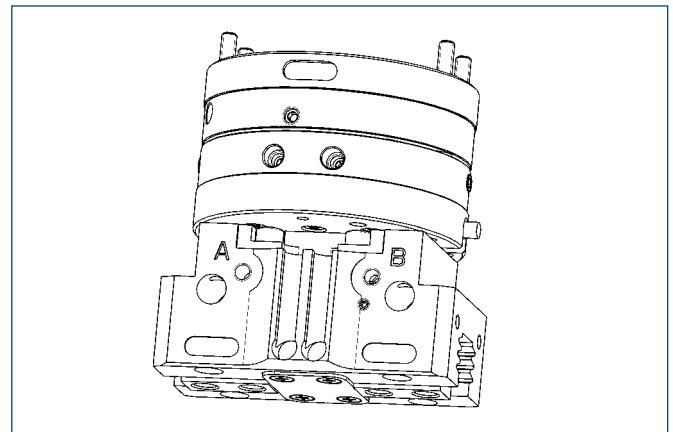
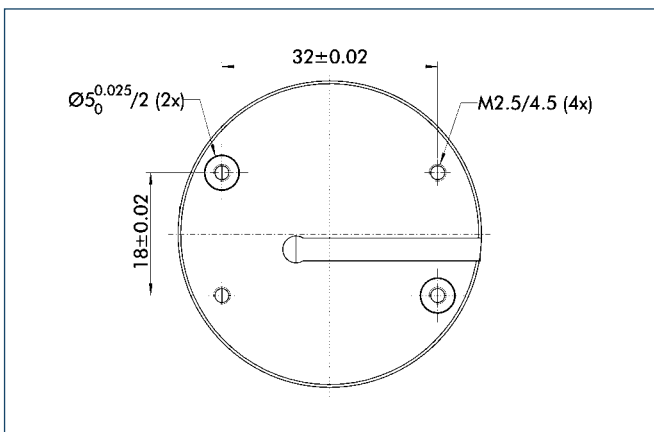

① Monitoring of the gripper is not possible (interference contour)

Mounting pattern for PZN-plus 40

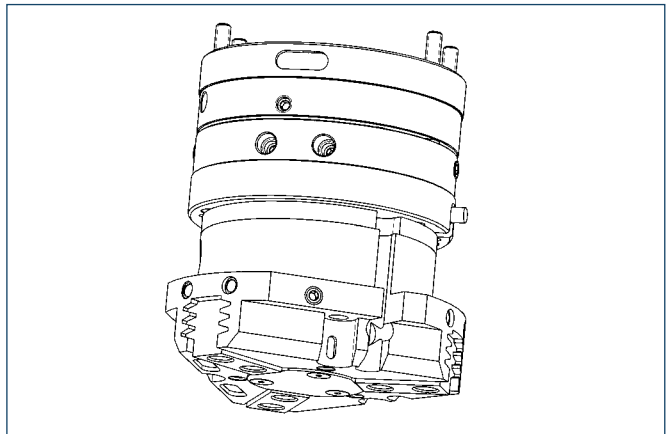
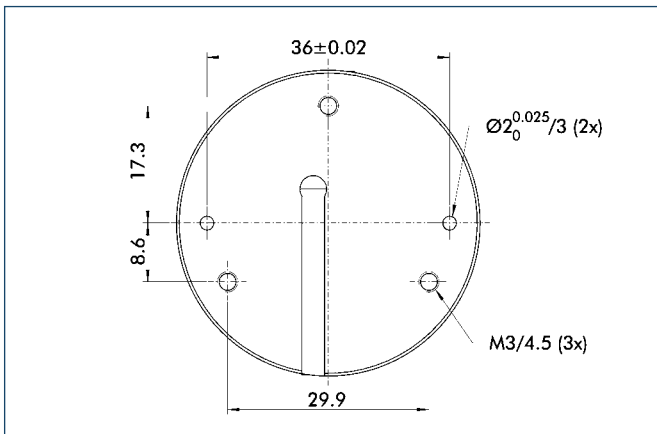

① Monitoring of the gripper is not possible (interference contour)

Adapter plate ISO 9409-31.5-4-M5

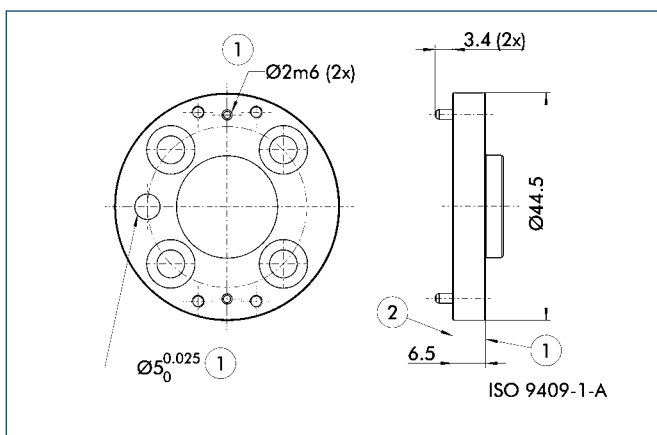

- ① Robot-side connection
- ② Tool-side connection

Adapter plate:

Robot-side adapter plate with ISO 9409-31.5-4-M5 screw connection diagram

Designation	ID
A-AGE-F-XY-031	0324903

 You can find more detailed information on, and individual parts for, the above-mentioned accessories in the "Accessories" catalog section.

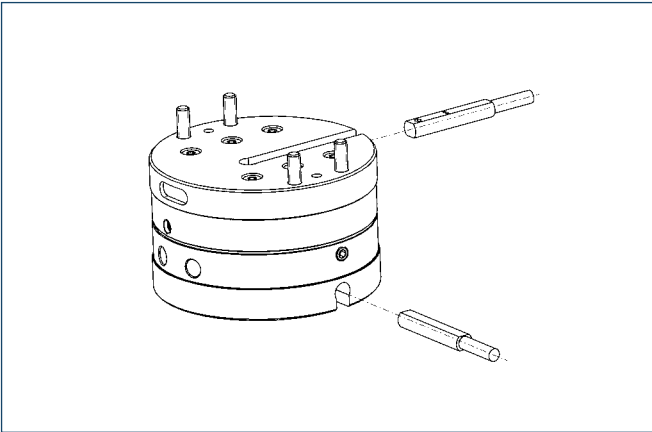
Sensor system

End position monitoring:
Electronic magnetic switches, for mounting in C-slot

Designation	ID
MMS-P-22-S-M8-PNP	0301370





Forces and moments

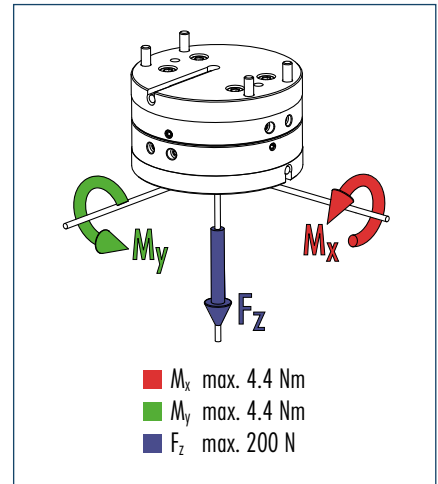

Technical data

Designation		AGE-FXY-040-1	AGE-FXY-040-2	AGE-FXY-040-3
	ID	0324920	0324921	0324922
Compensation stroke X	[mm]	± 2	± 2	± 2
Compensation stroke Y	[mm]	± 2	± 2	± 2
Workpiece weight recommendation	[kg]	4	4	4
Max. payload F_z	[N]	200	200	200
Max. payload F_d	[N]	500	500	500
Weight	[kg]	0.23	0.23	0.23
Moment M_x M_y	[Nm]	4.4	4.4	4.4
Moment M_z	[Nm]	8.0	8.0	8.0
Mass Moment of inertia I_z	[kg/cm ²]	on request	on request	on request
Mounting robot side		ISO 9409-40-4-M6 with adapter plate (optional)		
Mounting tool side		PGN-plus/PZN-plus 50		
Repeat accuracy	[mm]	± 0.003	± 0.003	± 0.003
Spring force	[N]	1.0	2.5	3.3
Spring rate	[N/mm]	0.6	0.8	1.4
Min. ambient temperature	[°C]	5.0	5.0	5.0
Max. ambient temperature	[°C]	80	80	80

Main views

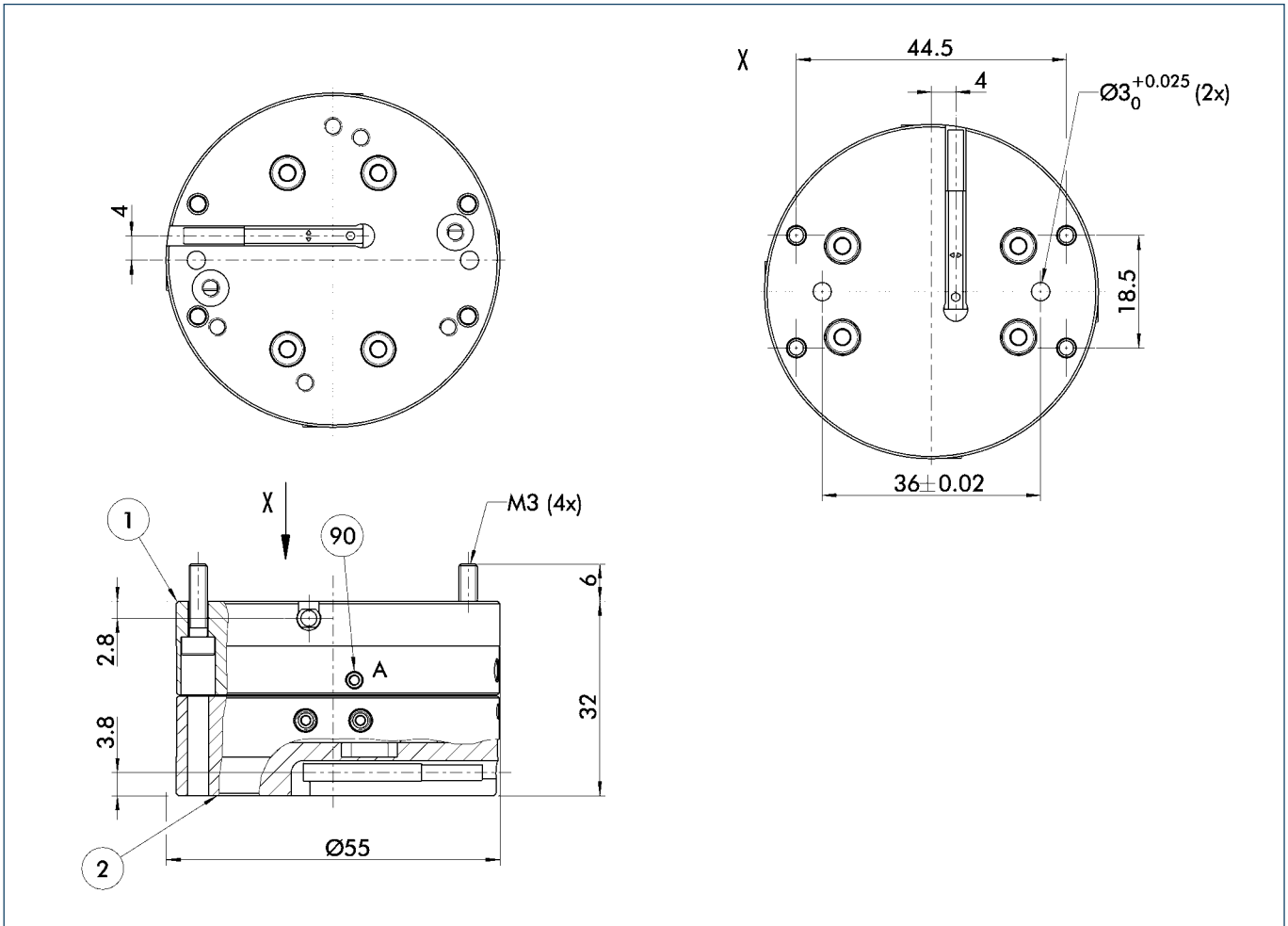

- ① Robot-side connection
- ② Tool-side connection
- ⊙ Adjustable stop for stroke limitation

Mounting pattern for PGN-plus 50

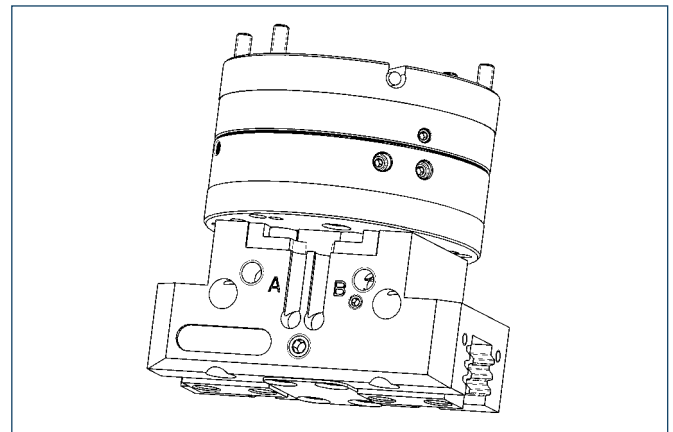
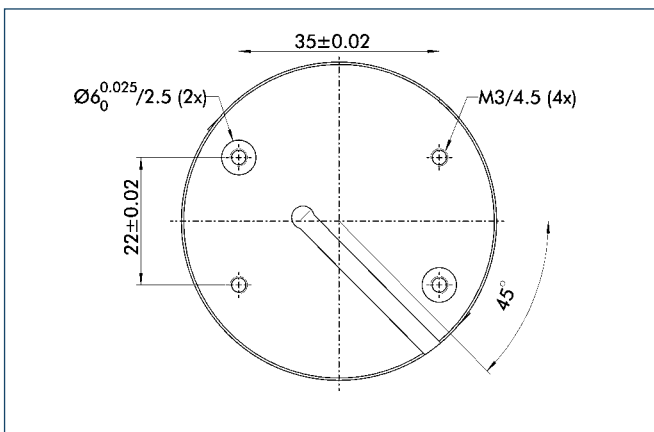

① Monitoring of the gripper is not possible (interference contour)

Mounting pattern for PZN-plus 50

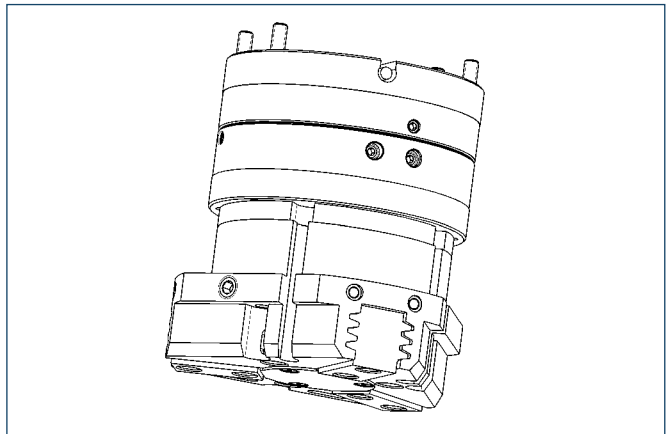
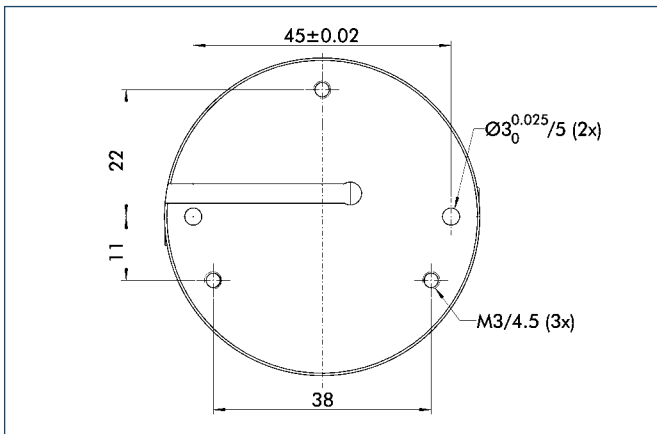

① Monitoring of the gripper is not possible (interference contour)

Adapter plate ISO 9409-40-4-M6

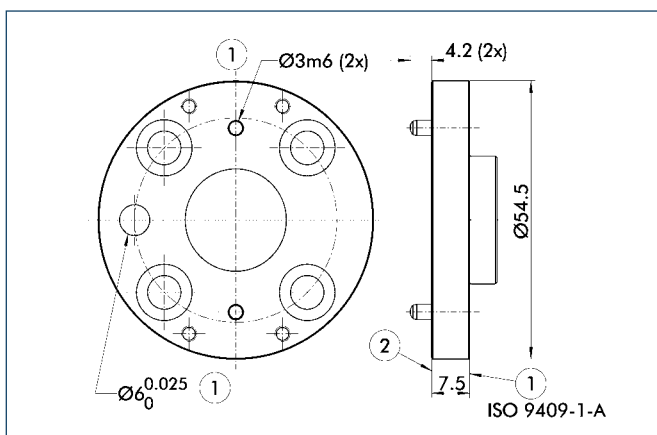

- ① Robot-side connection
- ② Tool-side connection

Adapter plate:

Robot-side adapter plate with ISO 9409-40-4-M6 screw connection diagram

Designation	ID
A-AGE-F-XY-040	0324923

 You can find more detailed information on, and individual parts for, the above-mentioned accessories in the "Accessories" catalog section.

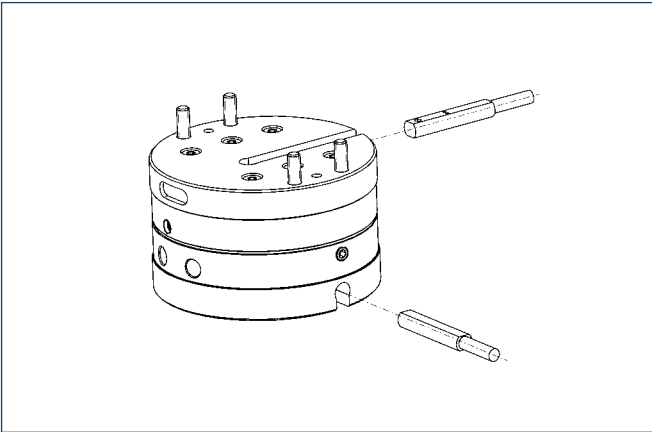
Sensor system

End position monitoring:

Electronic magnetic switches, for mounting in C-slot

Designation	ID
MMS-P-22-S-M8-PNP	0301370





Forces and moments

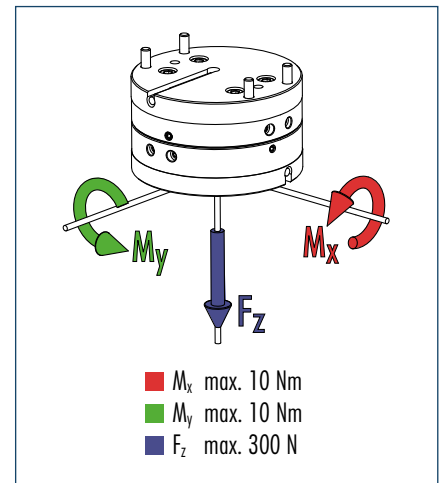

Technical data

Designation		AGE-F-XY-063-1	AGE-F-XY-063-2	AGE-F-XY-063-3
	ID	0324940	0324941	0324942
Compensation stroke X	[mm]	± 4	± 4	± 4
Compensation stroke Y	[mm]	± 4	± 4	± 4
Workpiece weight recommendation	[kg]	12.5	12.5	12.5
Max. payload F_z	[N]	300	300	300
Max. payload F_d	[N]	3000	3000	3000
Weight	[kg]	0.78	0.78	0.78
Moment M_x M_y	[Nm]	10	10	10
Moment M_z	[Nm]	21	21	21
Mass Moment of inertia I_z	[kg/cm ²]	on request	on request	on request
Mounting robot side		ISO 9409-63-4-M6 with adapter plate (optional)		
Mounting tool side		PGN-plus/PZN-plus 64 and 80		
Repeat accuracy	[mm]	± 0.004	± 0.004	± 0.004
Spring force	[N]	9.0	10.0	19.3
Spring rate	[N/mm]	1.5	4.1	3.9
Min. ambient temperature	[°C]	5.0	5.0	5.0
Max. ambient temperature	[°C]	80	80	80

Main views

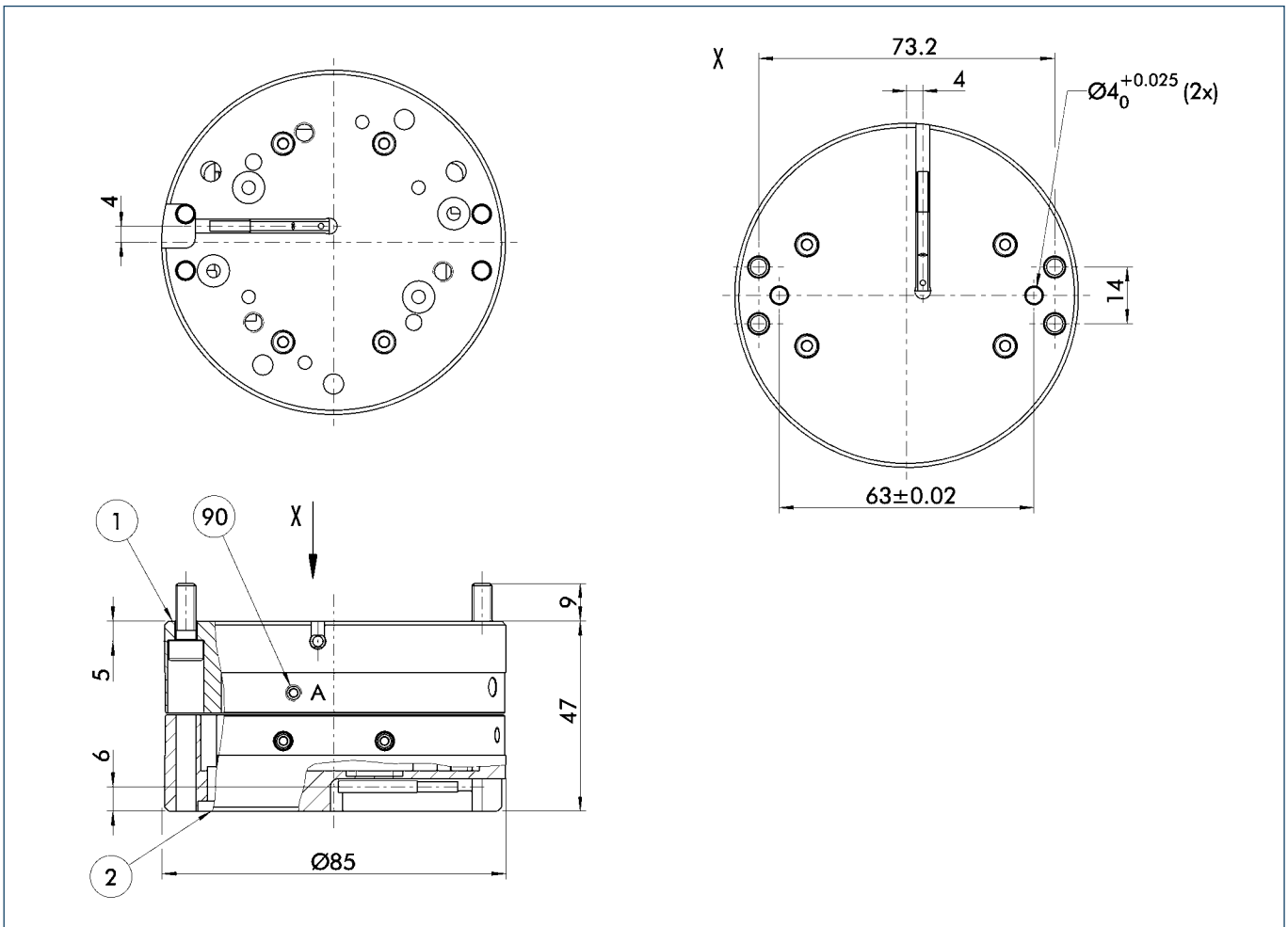

- ① Robot-side connection
- ② Tool-side connection
- ⑨⑩ Adjustable stop for stroke limitation

Mounting pattern for PGN-plus 64

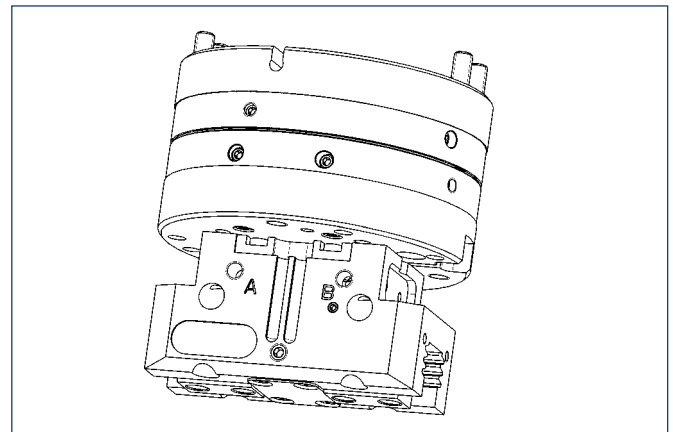
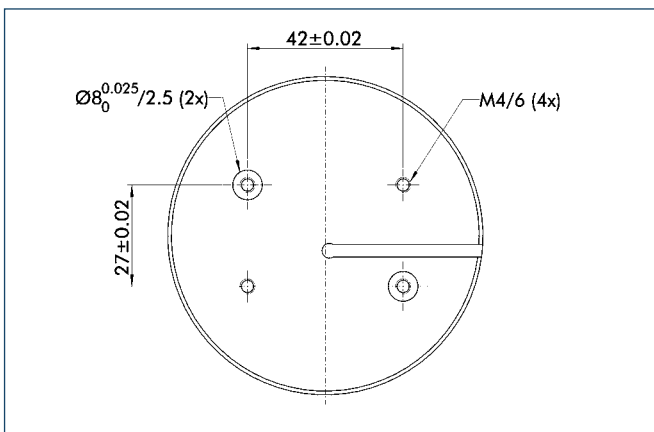

① Monitoring of the gripper is not possible (interference contour)

Mounting pattern for PZN-plus 64

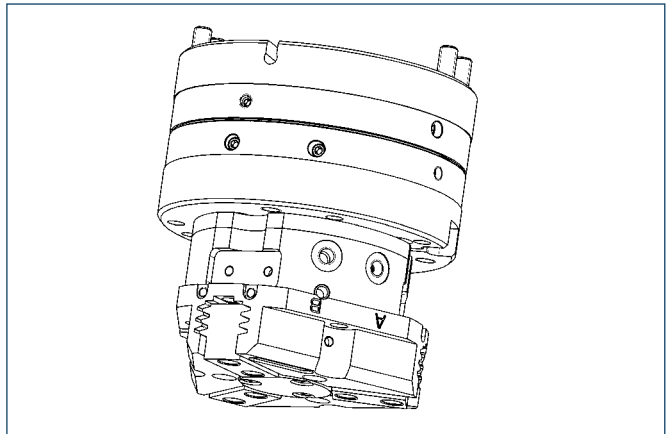
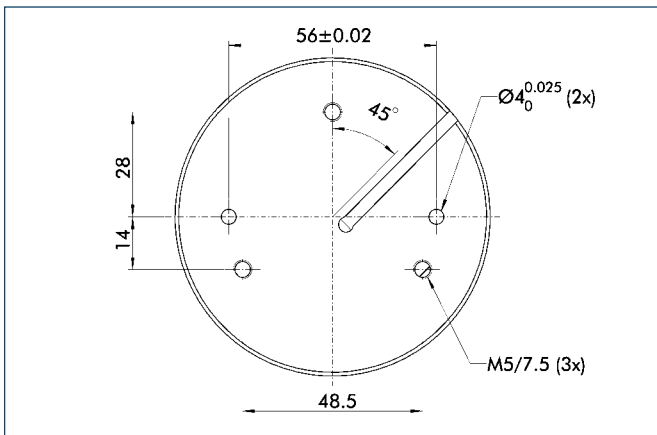

① Monitoring of the gripper is not possible (interference contour)

Mounting pattern for PGN-plus 80

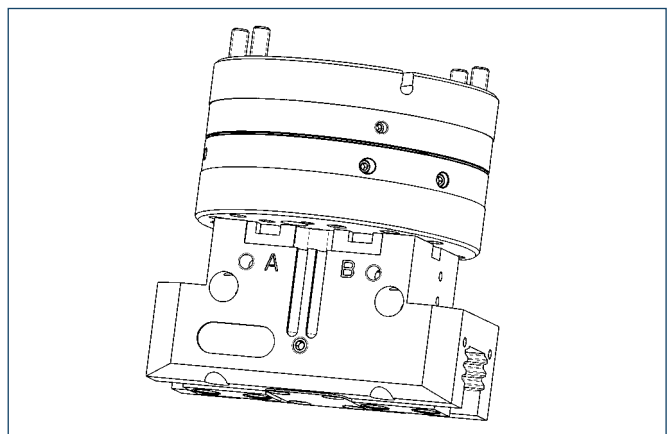
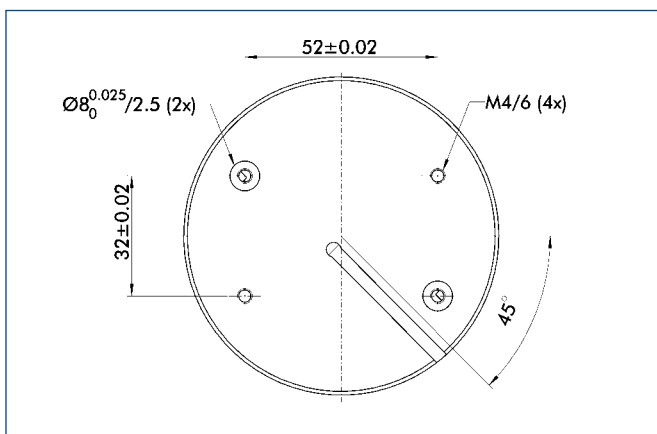

① Monitoring of the gripper is not possible (interference contour)

 You can find more detailed information on, and individual parts for, the above-mentioned accessories in the "Accessories" catalog section.

Mounting pattern for PZN-plus 80

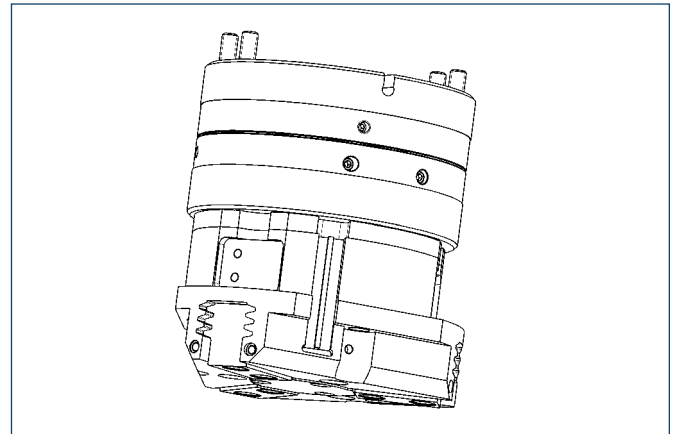
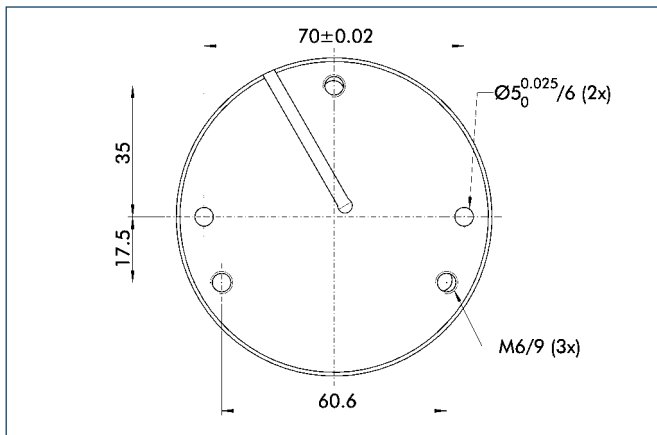

① Monitoring of the gripper is not possible (interference contour)

Adapter plate ISO 9409-63-4-M6

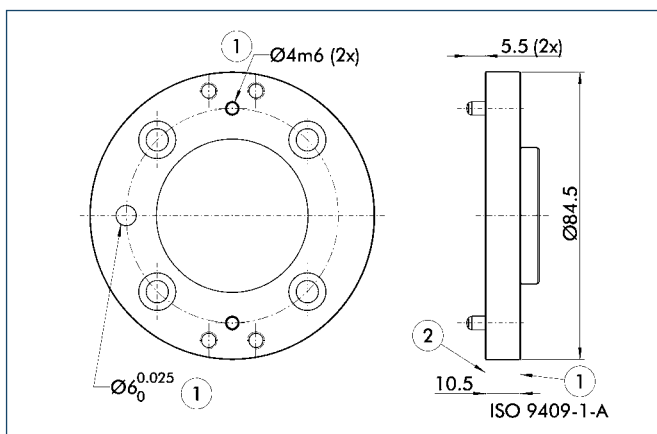

- ① Robot-side connection
- ② Tool-side connection

Adapter plate:

Robot-side adapter plate with ISO 9409-63-4-M6 screw connection diagram

Designation	ID
A-AGE-F-XY-063	0324943

Sensor system

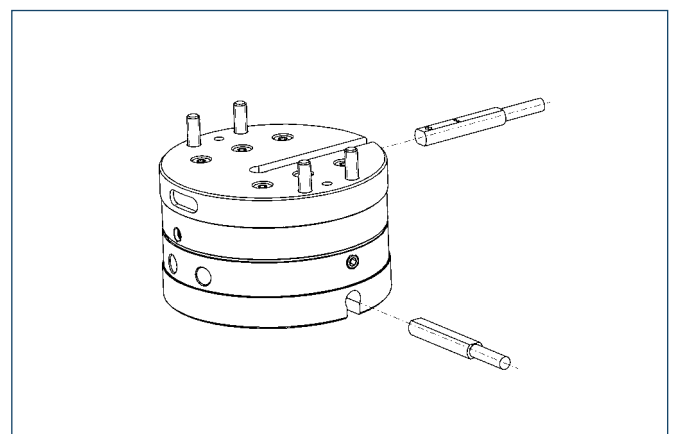

End position monitoring:

Electronic magnetic switches, for mounting in C-slot

Designation	ID
MMS-P-22-S-M8-PNP	0301370

Forces and moments

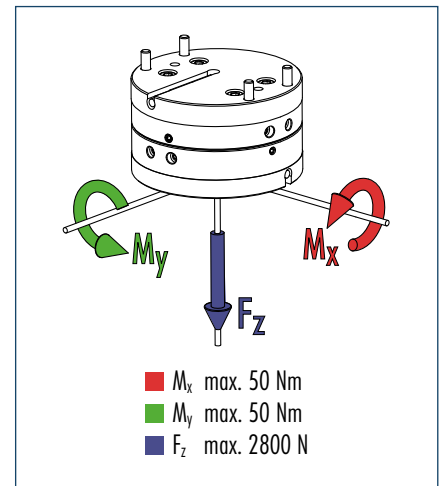

Technical data

Designation		AGE-F-XY-080-1	AGE-F-XY-080-2	AGE-F-XY-080-3
	ID	0324960	0324961	0324962
Compensation stroke X	[mm]	± 5	± 5	± 5
Compensation stroke Y	[mm]	± 5	± 5	± 5
Workpiece weight recommendation	[kg]	32.3	32.3	32.3
Max. payload F_z	[N]	2800	2800	2800
Max. payload F_d	[N]	12000	12000	12000
Weight	[kg]	3.13	3.13	3.13
Moment M_x M_y	[Nm]	50	50	50
Moment M_z	[Nm]	150	150	150
Mass Moment of inertia I_z	[kg/cm ²]	on request	on request	on request
Mounting robot side		ISO 9409-80-6-M8 with adapter plate (optional)		
Mounting tool side		PGN-plus/PZN-plus 100 and 125		
Repeat accuracy	[mm]	± 0.008	± 0.008	± 0.008
Spring force	[N]	28.3	42.5	47.6
Spring rate	[N/mm]	7.0	12.1	18.3
Min. ambient temperature	[°C]	5.0	5.0	5.0
Max. ambient temperature	[°C]	80	80	80

Main views

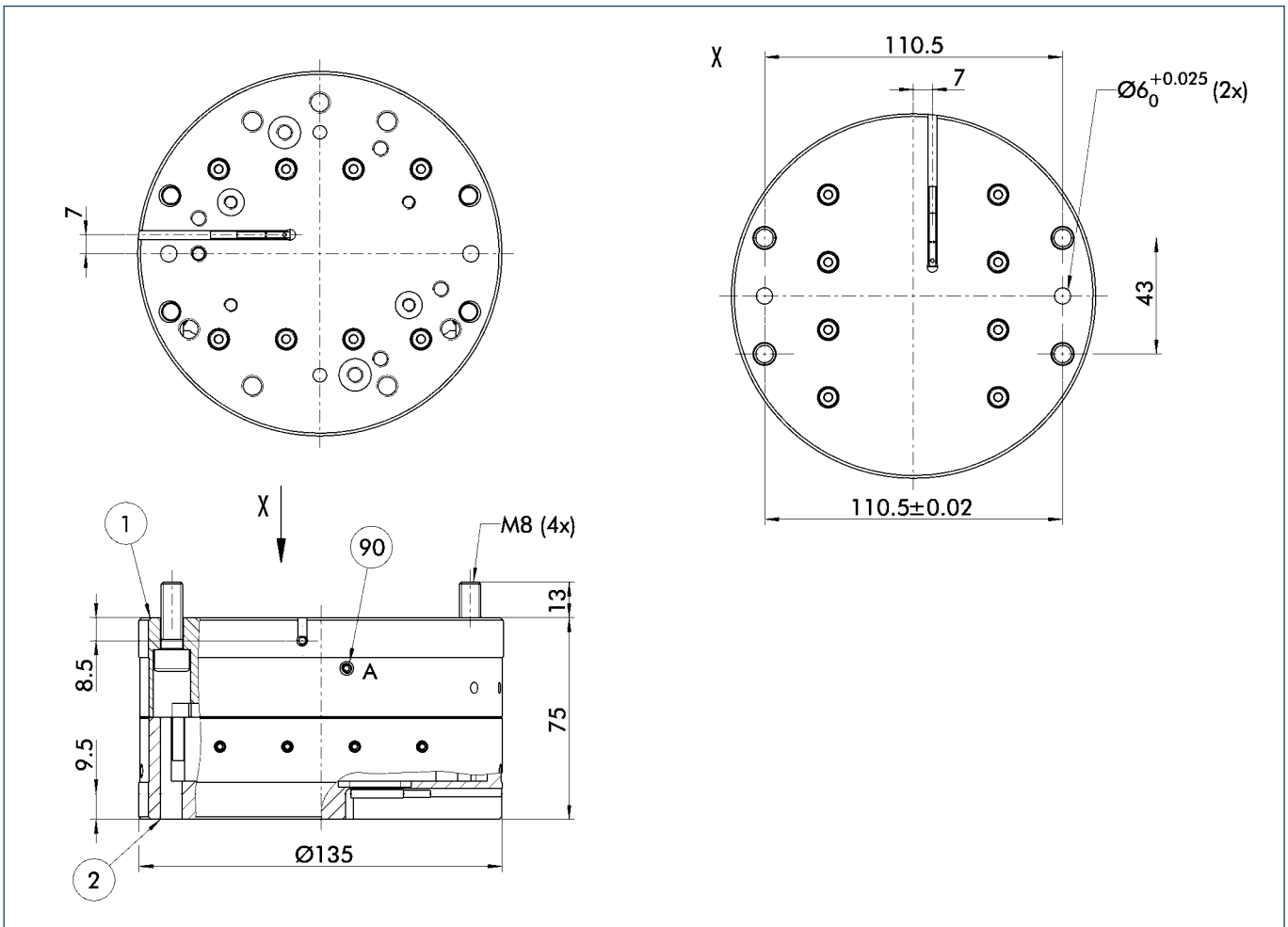

- ① Robot-side connection
- ② Tool-side connection
- ⑨ Adjustable stop for stroke limitation

Mounting pattern for PGN-plus 100

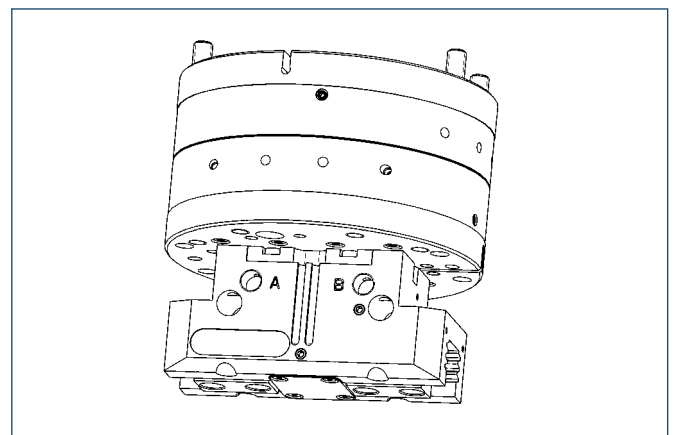
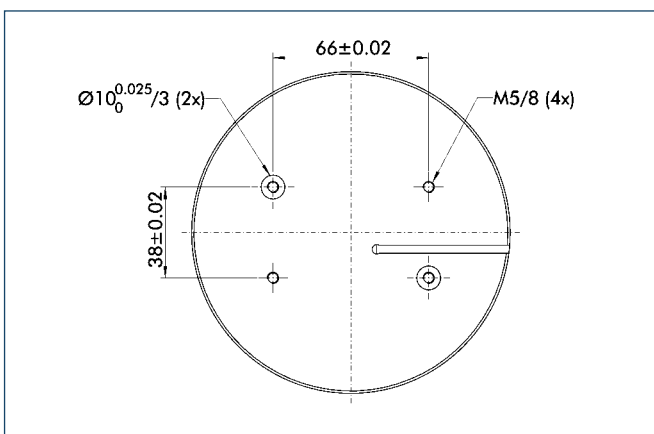

① Monitoring of the gripper is not possible (interference contour)

Mounting pattern for PZN-plus 100

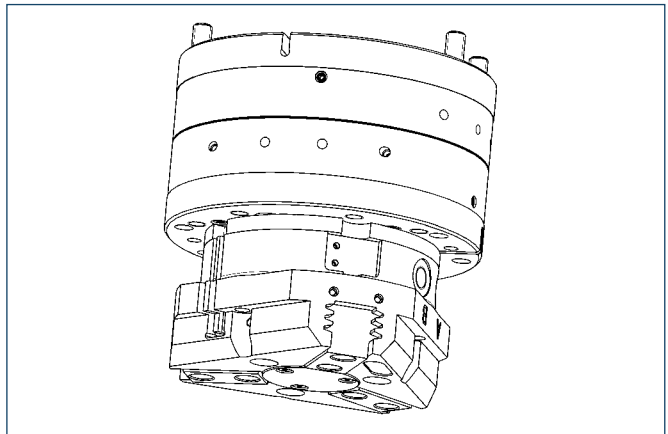
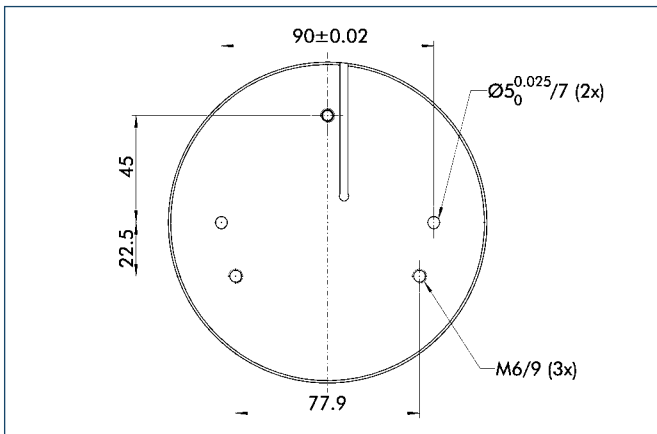

① Monitoring of the gripper is not possible (interference contour)

Mounting pattern for PGN-plus 125

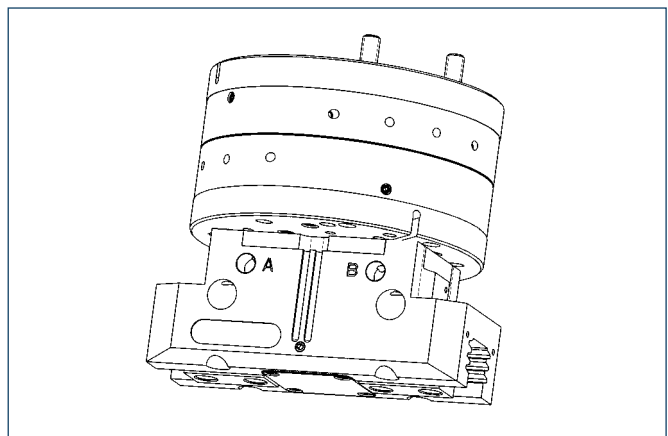
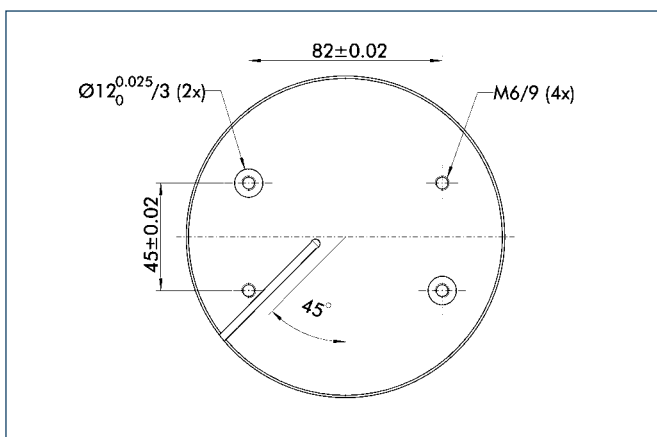

① Monitoring of the gripper is not possible (interference contour)

 You can find more detailed information on, and individual parts for, the above-mentioned accessories in the "Accessories" catalog section.

Mounting pattern for PZN-plus 125

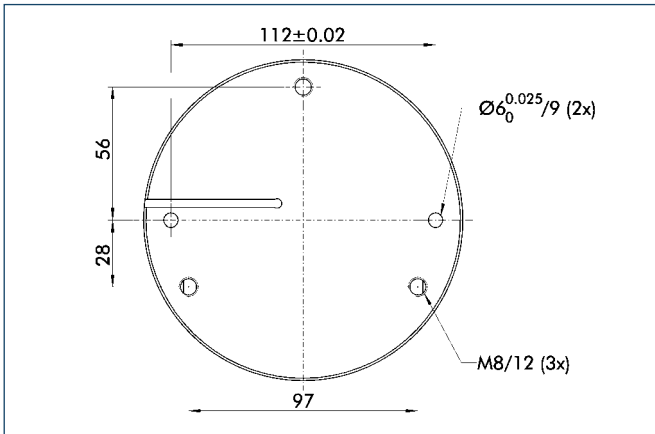

① Monitoring of the gripper is not possible (interference contour)

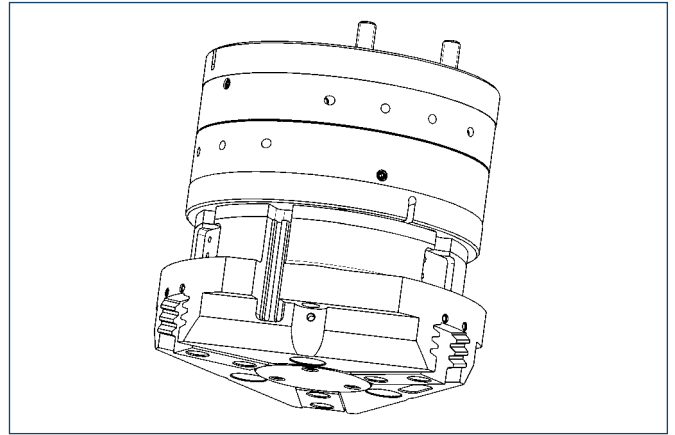

Adapter plate ISO 9409-80-6-M8

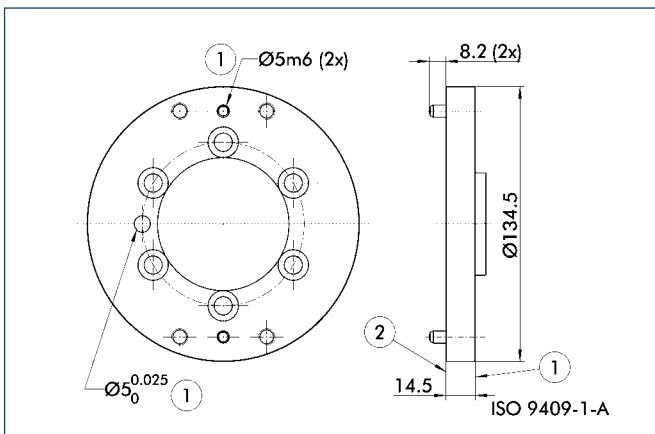

- ① Robot-side connection
- ② Tool-side connection

Adapter plate:

Robot-side adapter plate with ISO 9409-80-6-M8 screw connection diagram

Designation	ID
A-AGE-F-XY-080	0324963

Sensor system

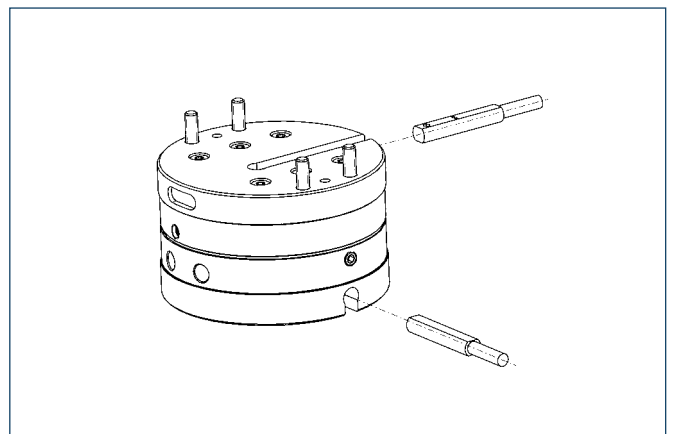

End position monitoring:

Electronic magnetic switches, for mounting in C-slot

Designation	ID
MMS-P-22-S-M8-PNP	0301370



Sizes
100 .. 200



Payload
up to 100 kg

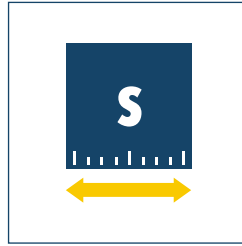

Compensation path XY
up to ± 14 mm



Compensation path Z
up to 12 mm

Application example

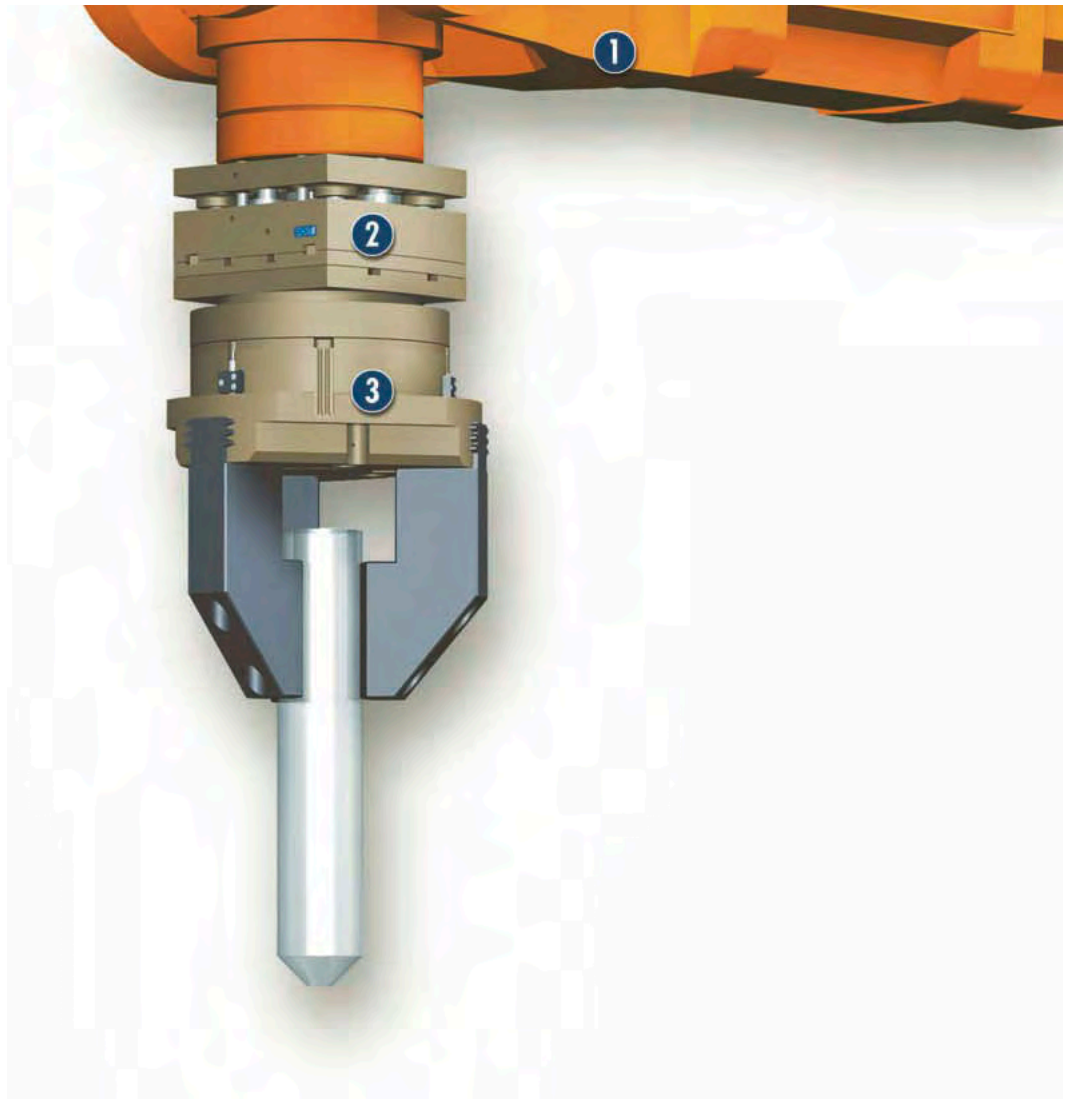

Picking up and setting down components
from a rack with a 3-finger centric gripper

- 1 Robot
- 2 AGE-S 100 Compensation Unit
- 3 PZN-plus 100 3-Finger Centric Gripper

Compensation Unit

Compensation unit with X, Y and Z axis flexibility

Area of application

For assembling, palletizing and inserting workpieces

Your advantages and benefits

ISO flange

for easy mounting to most types of robots without additional adapter plates

Three compensation directions in one unit

compact design for minimum profile

Centric locking

for fixing the unit rigidly in a defined, centric position

Pneumatic position storage

for secure retention of the offset position



General information on the series

Compensation paths

X, Y direction: up to ± 12 mm

Z direction: up to 14 mm

Guides

Sturdy linear guides

Actuation

Pneumatic, filtered compressed air (10 μ m): dry, lubricated or non-lubricated

Operating pressure range

2 bar to 8 bar

Monitoring of centric locking

Via electronic magnetic switch

Z-stroke monitoring

Via inductive proximity switches

Ambient temperature

5 °C to 60 °C

Material

Aluminum alloy, hard-anodized
Functional components made from hardened steel

Warranty

24 months

Sectional diagram

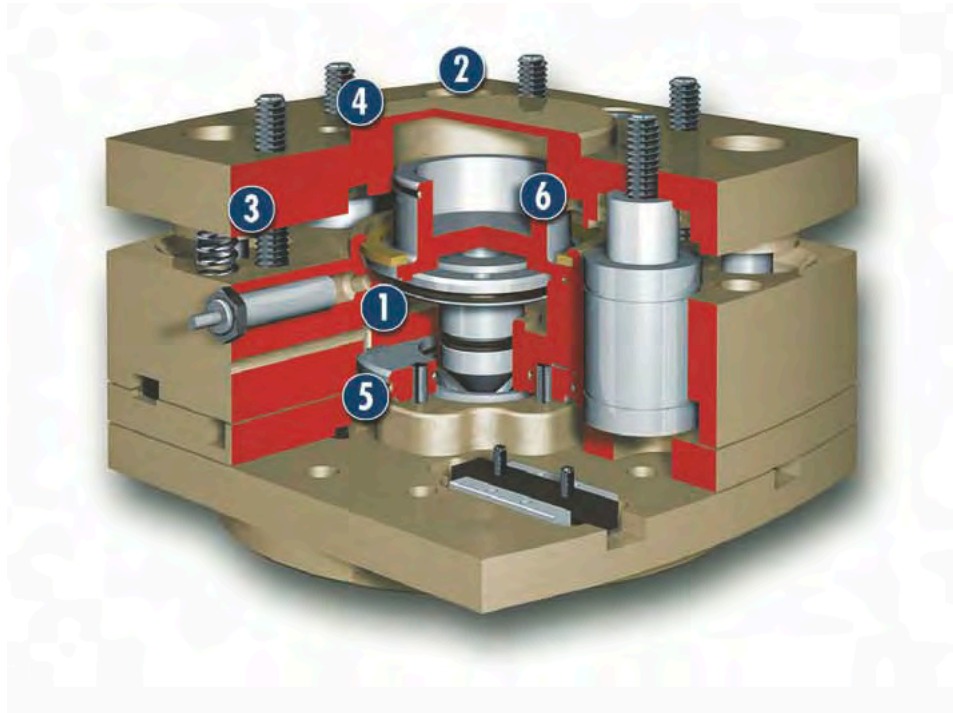

- 1 Position Storage**
locking in any position via two pneumatically driven pistons and frictional contact
- 2 Direct Mounting**
by means of standardized ISO 9409 interface for robots
- 3 Monitoring**
locking piston stroke monitoring with electronic magnetic switch
- 4 Housing**
weight-reduced through the use of a hard-anodized, high-strength aluminum alloy
- 5 Compensating Element**
for compensating positioning errors in the X-Y plane
- 6 Locking Mechanism**
pneumatically operated centric locking

Function description

The AGE-S is an expansion to the AGE range (AGE-XY/ AGE-Z) for the medium and heavy load sector and provides perfect compensation in all automation tasks. Robust guidance with excellent stability allows very high loading weights on maximum compensation paths. During handling in directions XY and Z, the unit can be made rigid via the integrated pneumatic locking facility.

Accessories

Accessories from SCHUNK – the suitable supplement for maximum functionality, reliability and performance of all automation modules.

Fittings



IN inductive proximity switches



Sensor cables



MMS magnetic switches



① For the exact size of the accessories, the availability for this size and the designation and ID, please refer to the additional views at the end of the size in question. You can find more detailed information on our accessory range in the "Accessories" catalog section.

General information on the series

Extreme ambient conditions

Please note that use in extreme ambient conditions (e.g. in the coolant zone, in the presence of abrasive dust) can significantly reduce the tool life span of these units and we cannot accept any liability for this reduction. However, in many cases we have a solution at hand. Please ask for details.

AGE-S-100

Compensation · XYZ Compensation Units · **Heavy Loads**



Forces and moments

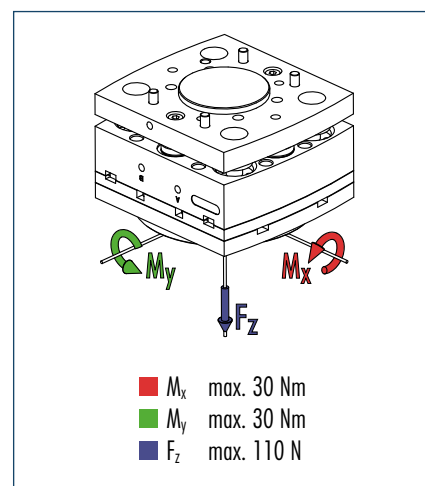

Technical data

Designation		AGE-S-100-XYZ-0	AGE-S-100-XYZ-P	AGE-S-100-XY-0	AGE-S-100-XY-P	AGE-S-100-Z
	ID	0324502	0324504	0324500	0324503	0324501
X/Y stroke	[mm]	± 4	± 4	± 4	± 4	-
Z stroke	[mm]	10	10	-	-	10
Locking force at 6 bar	[N]	800	800	800	800	-
Max. payload	[kg]	5.5	5.5	5.5	5.5	5.5
Position storage force	[N]	-	1100	-	1100	-
Piston force Z	[N]	800	800	-	-	800
Spring force Z	[N]	240 - 300	240 - 300	-	-	240 - 300
Weight	[kg]	3.6	3.6	2.6	2.6	3.2

Main views

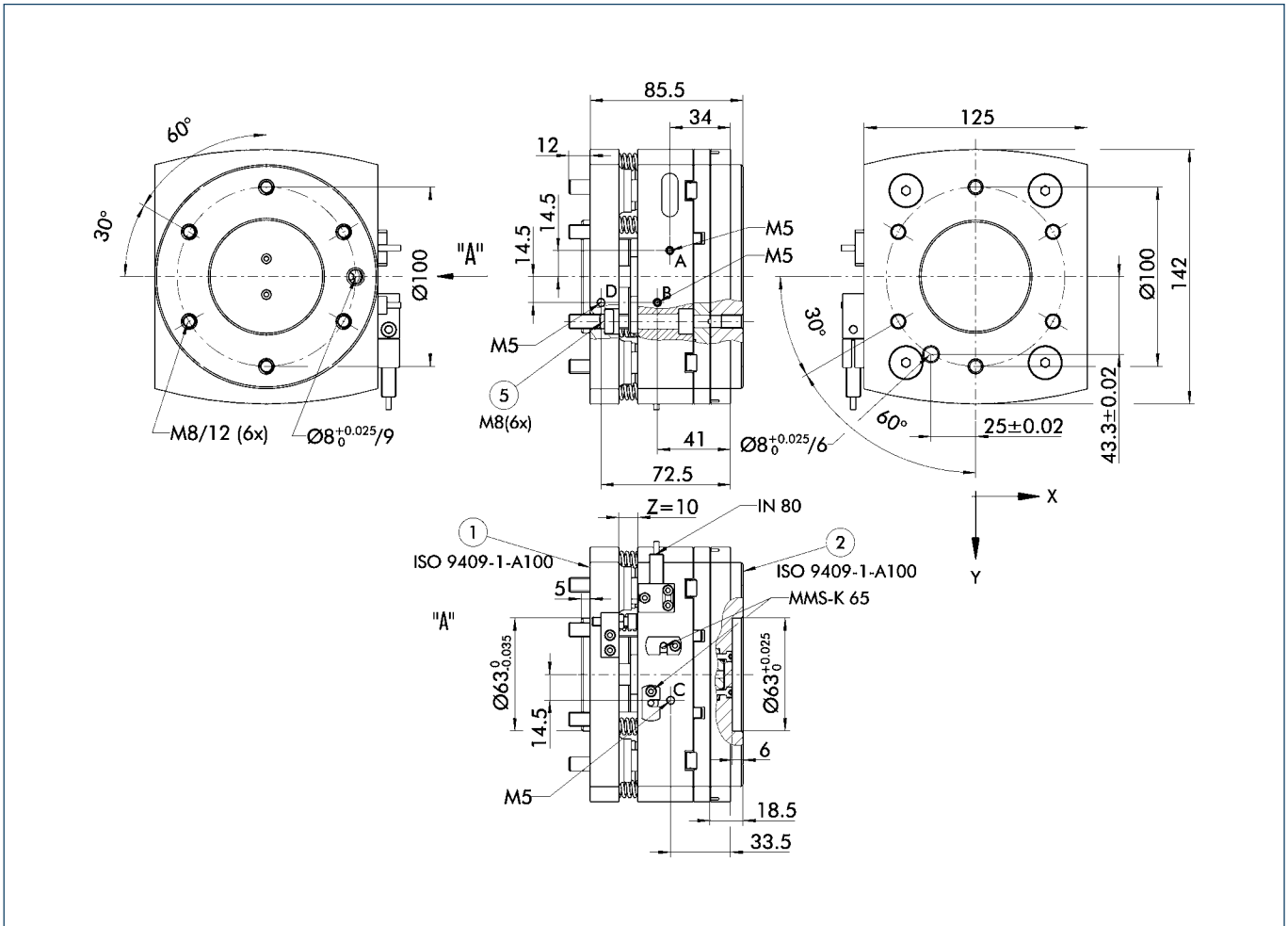

- A Unlocked air connection
- B Locked air connection
- C Air connection position storage XY
- D Locked air connection Z
- ① Robot-side connection
- ② Tool-side connection
- ⑤ Through-bore for screw connection with screw (enclosed)

Change in dimension AGE-S-100-XY

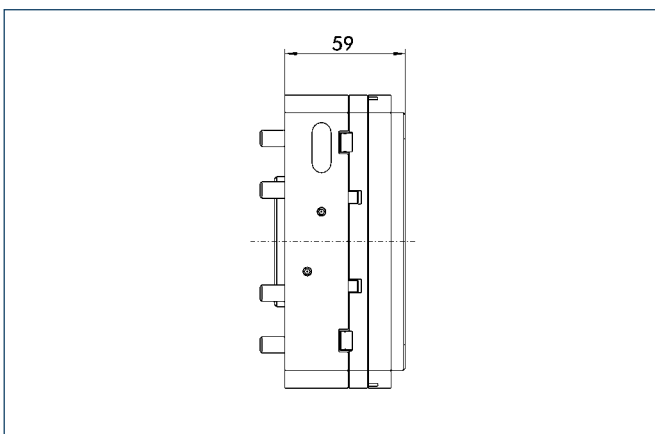

Change in dimension AGE-S-100-Z

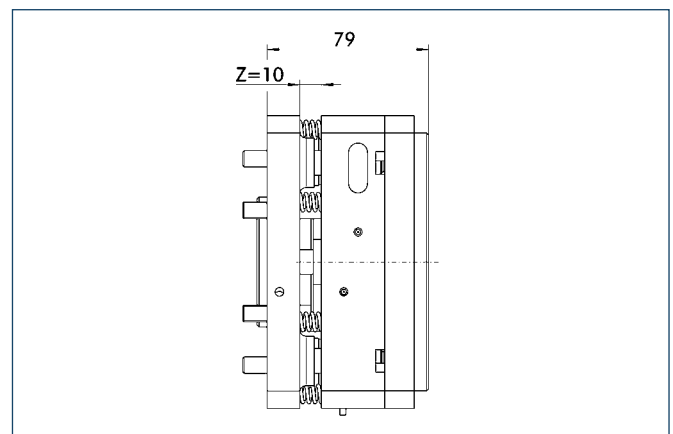

Sensor system

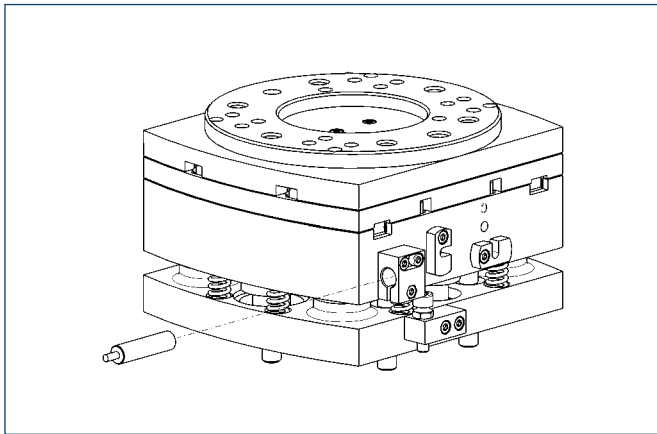

Z stroke monitoring:

Inductive proximity switches, for direct mounting

Designation	ID	Recommended product
IN 80/S-M12	0301578	
IN 80/S-M8	0301478	•
IN-B 80/S-M8	0301477	
INK 80/S	0301550	

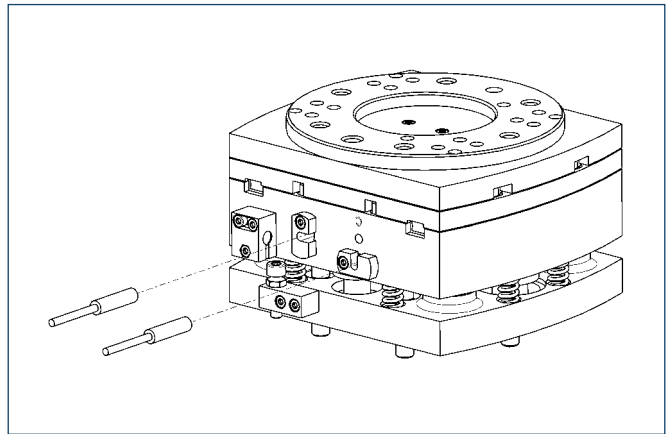

Centric locking monitoring:

Electronic magnetic switch

Designation	ID
MMS-K 65/S-PNP	0301423
MMS-K 65/S NPN	0301424

- ① Two sensors (closers/S) are required for each compensation unit, plus extension cables as an option.

Extension cables for proximity switches/magnetic switches

Designation	ID
GK 3-M8	0301622
GK 3-M5-PNP/NPN	0301652
KV 10-M12	0301596
KV 10-M8	0301496
KV 20-M12	0301597
KV 20-M8	0301497
KV 3-M12	0301595
KV 3-M8	0301495
W 3-M12	0301503
W 5-M12	0301507
W 3-M5-PNP/NPN	0301650
WK 3-M8	0301594
WK 3-M8 NPN	0301602
WK 5-M8	0301502
WK 5-M8 NPN	9641116

- ① Please note the minimum permitted bending radii for the sensor cables, which are generally 35 mm.



You can find more detailed information on, and individual parts for, the above-mentioned accessories in the "Accessories" catalog section.

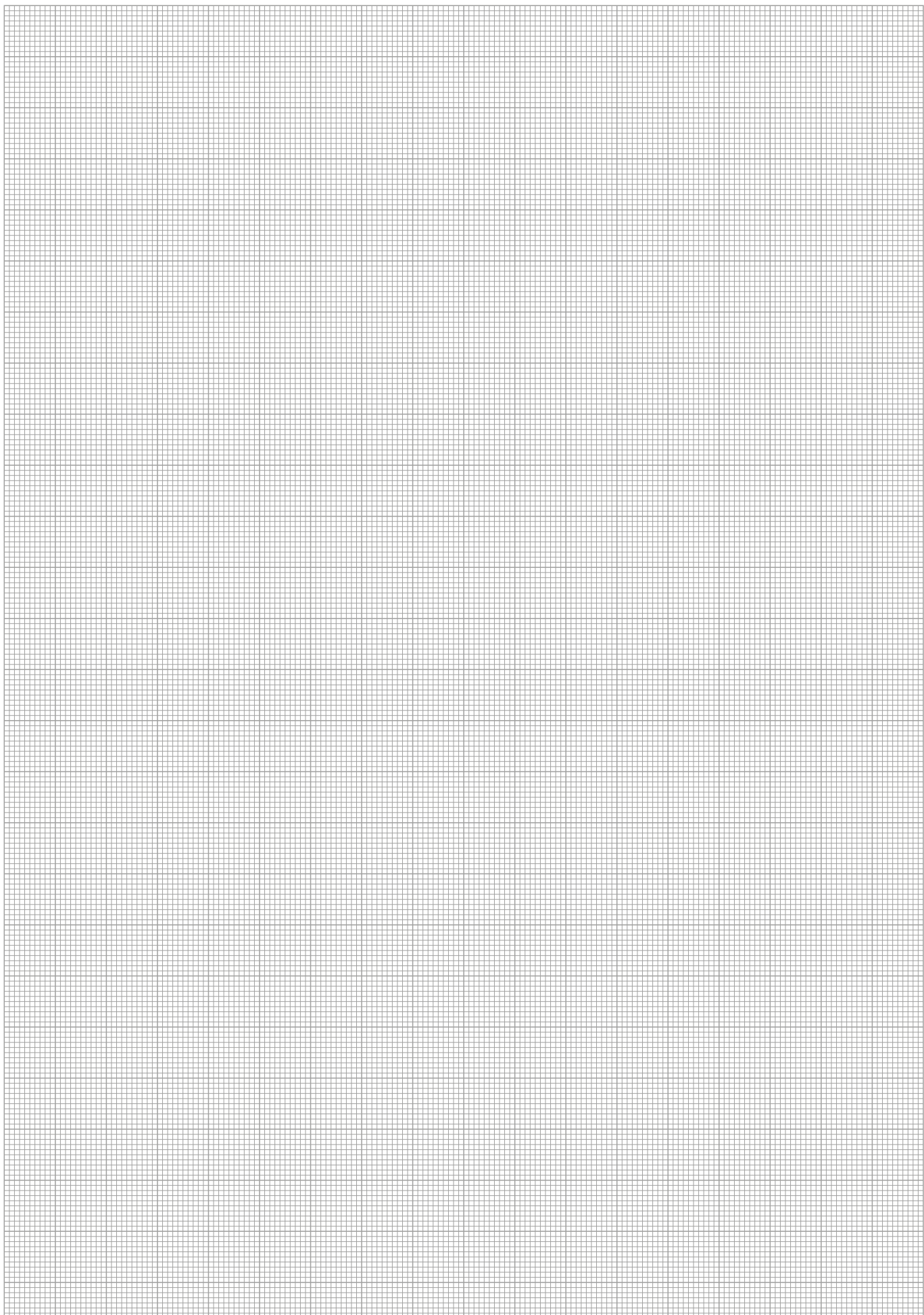

AGE-S-125

Compensation · XYZ Compensation Units · **Heavy Loads**



Forces and moments

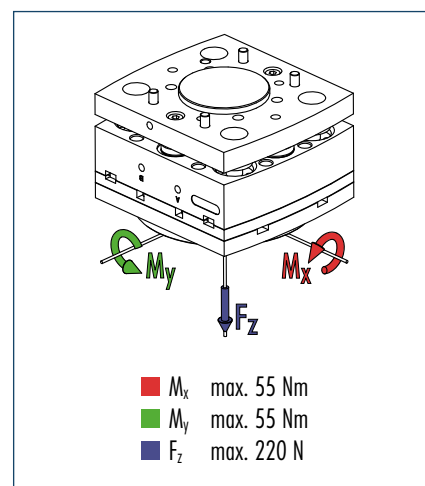

Technical data

Designation		AGE-S-125-XYZ-0	AGE-S-125-XYZ-P	AGE-S-125-XY-0	AGE-S-125-XY-P	AGE-S-125-Z
	ID	0324527	0324529	0324525	0324528	0324526
X/Y stroke	[mm]	± 7	± 7	± 7	± 7	-
Z stroke	[mm]	12	12	-	-	12
Locking force at 6 bar	[N]	1100	1100	1100	1100	-
Max. payload	[kg]	11	11	11	11	11
Position storage force	[N]	-	1700	-	1700	-
Piston force Z	[N]	1200	1200	-	-	1200
Spring force Z	[N]	360 - 490	360 - 490	-	-	360 - 490
Weight	[kg]	7.4	7.4	5.3	5.3	6.0

Main views

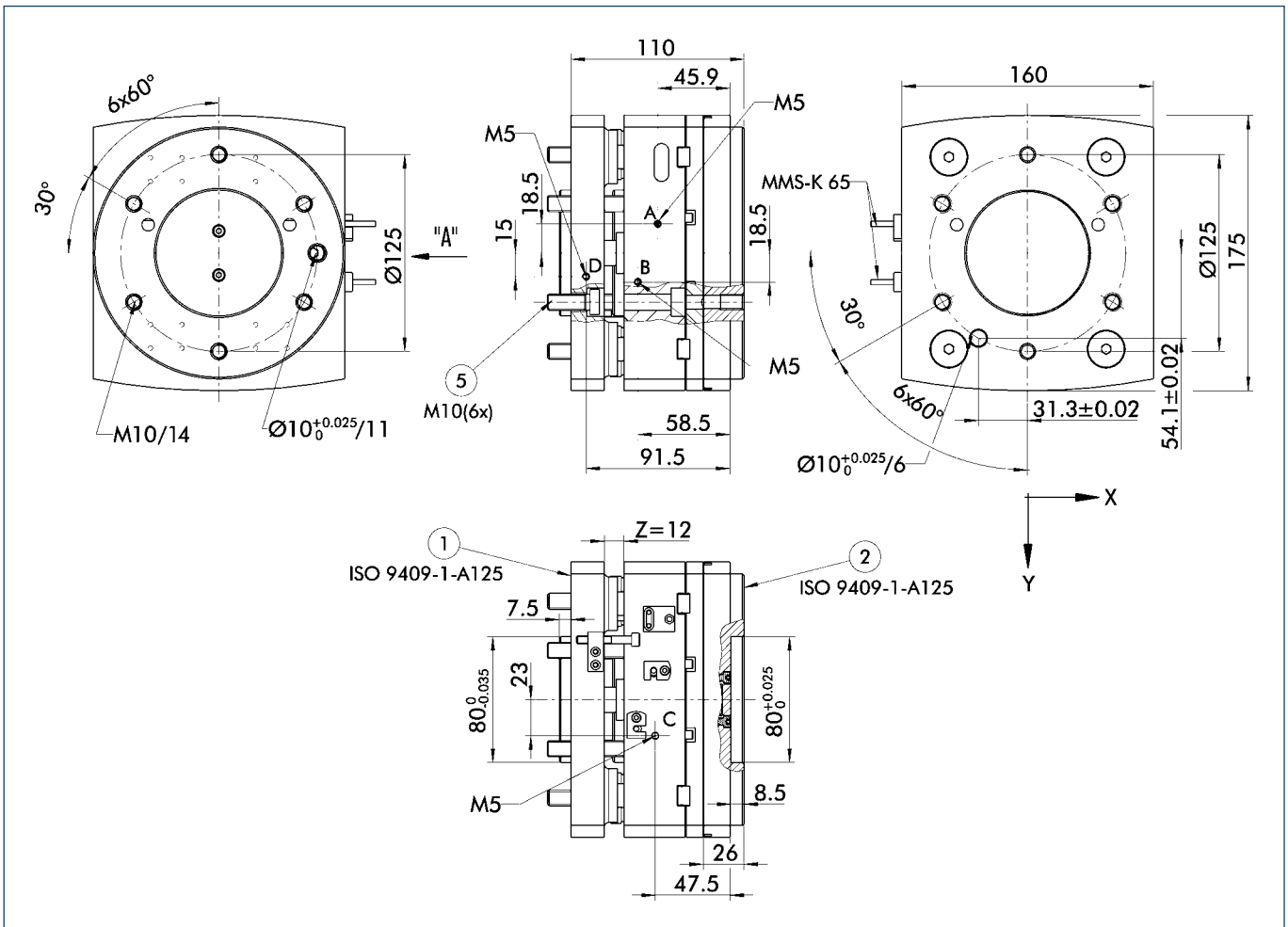

- A Unlocked air connection
- B Locked air connection
- C Air connection position storage XY
- D Locked air connection Z
- ① Robot-side connection
- ② Tool-side connection
- ⑤ Through-bore for screw connection with screw (enclosed)

Change in dimension AGE-S-125-XY

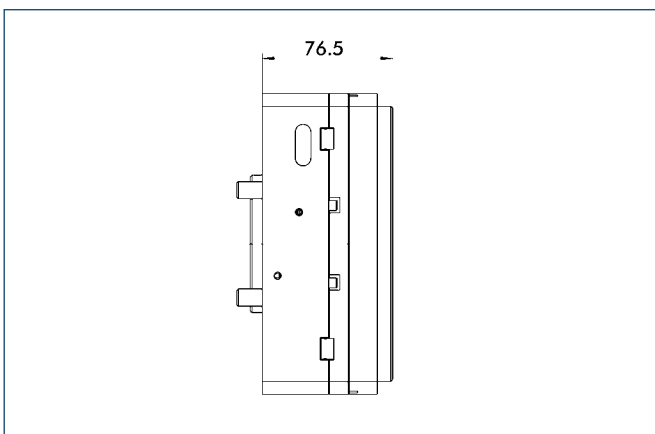

Change in dimension AGE-S-125-Z

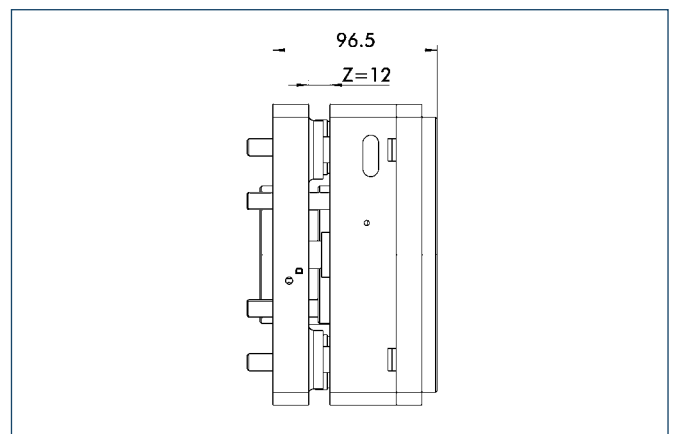

Sensor system

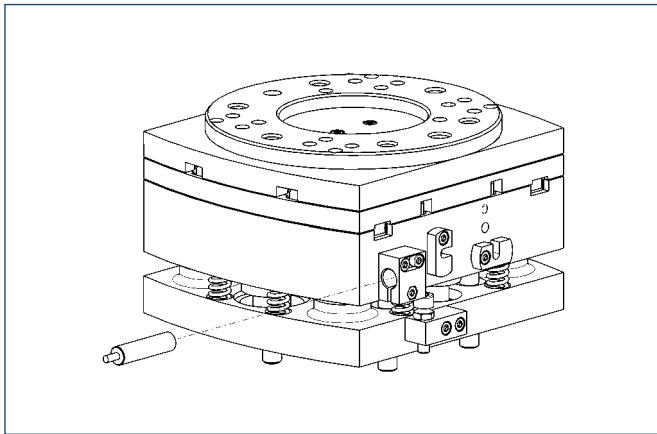

Z stroke monitoring:

Inductive proximity switches, for direct mounting

Designation	ID	Recommended product
IN 80/S-M12	0301578	
IN 80/S-M8	0301478	•
IN-B 80/S-M8	0301477	
INK 80/S	0301550	

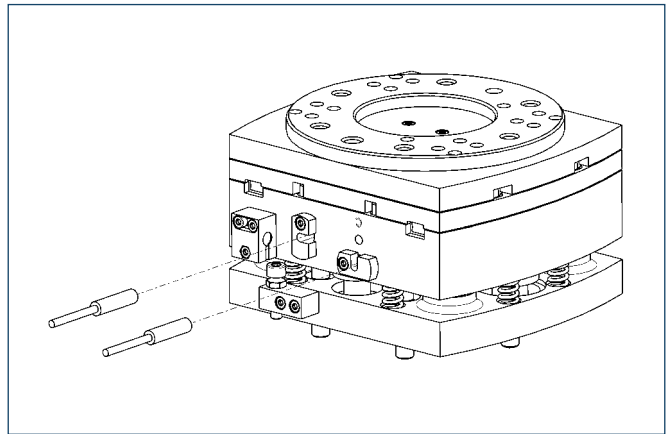

Centric locking monitoring:

Electronic magnetic switch

Designation	ID
MMS-K 65/S-PNP	0301423
MMS-K 65/S NPN	0301424

- ① Two sensors (closers/S) are required for each compensation unit, plus extension cables as an option.

Extension cables for proximity switches/magnetic switches

Designation	ID
GK 3-M8	0301622
GK 3-M5-PNP/NPN	0301652
KV 10-M12	0301596
KV 10-M8	0301496
KV 20-M12	0301597
KV 20-M8	0301497
KV 3-M12	0301595
KV 3-M8	0301495
W 3-M12	0301503
W 5-M12	0301507
W 3-M5-PNP/NPN	0301650
WK 3-M8	0301594
WK 3-M8 NPN	0301602
WK 5-M8	0301502
WK 5-M8 NPN	9641116

- ① Please note the minimum permitted bending radii for the sensor cables, which are generally 35 mm.



You can find more detailed information on, and individual parts for, the above-mentioned accessories in the "Accessories" catalog section.

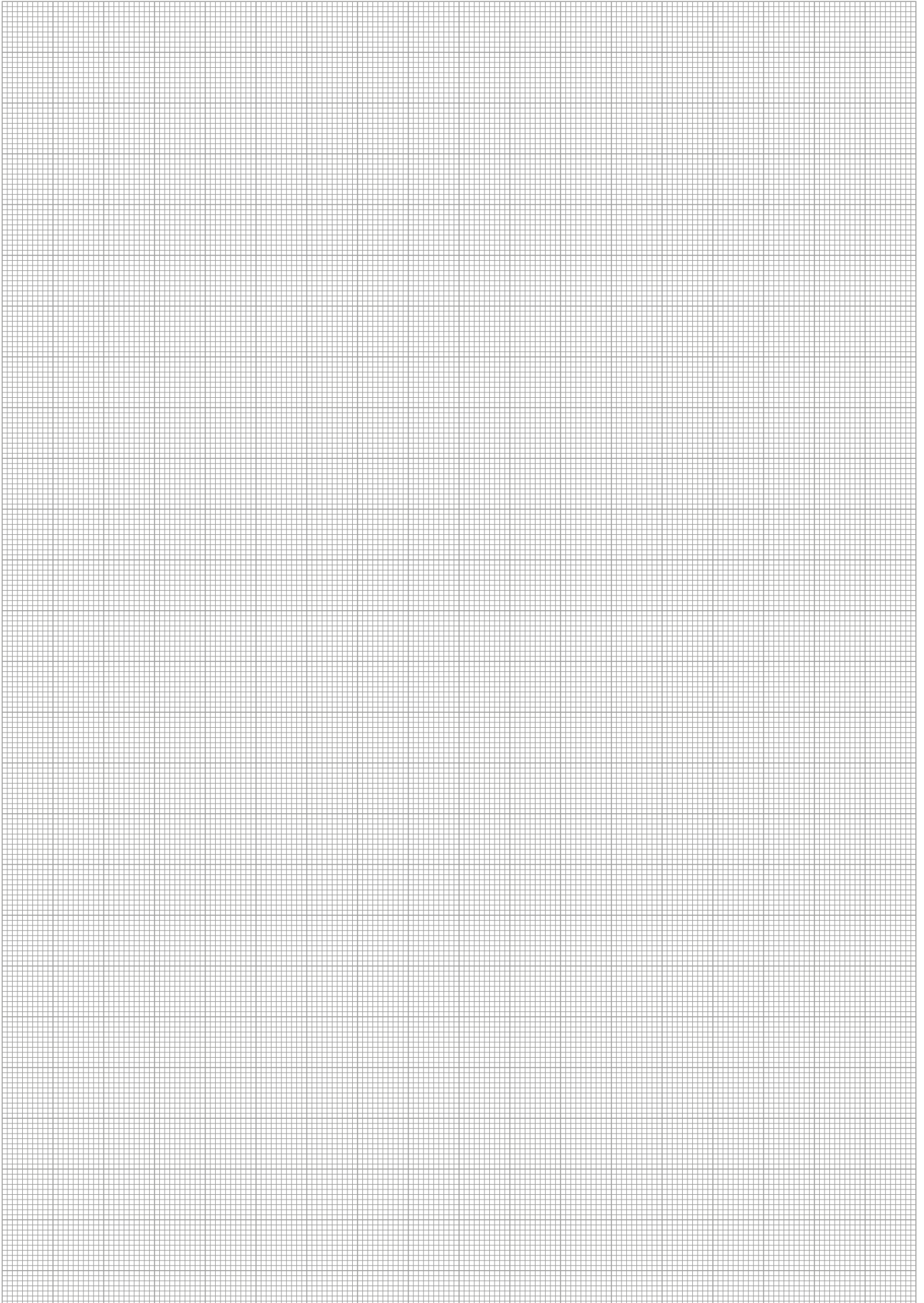

AGE-S-160

Compensation · XYZ Compensation Units · **Heavy Loads**



Forces and moments

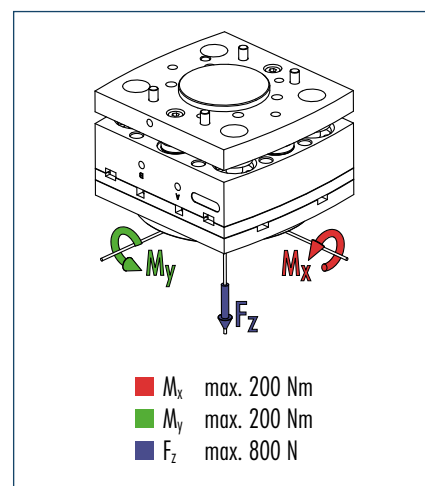

Technical data

Designation		AGE-S-160-XYZ-0	AGE-S-160-XYZ-P	AGE-S-160-XY-0	AGE-S-160-XY-P	AGE-S-160-Z
	ID	0324562	0324564	0324560	0324563	0324561
X/Y stroke	[mm]	± 10	± 10	± 10	± 10	-
Z stroke	[mm]	14	14	-	-	14
Locking force at 6 bar	[N]	1800	1800	1800	1800	-
Max. payload	[kg]	40	40	40	40	40
Position storage force	[N]	-	2900	-	2900	-
Piston force Z	[N]	1900	1900	-	1900	1900
Spring force Z	[N]	640 - 1000	640 - 1000	-	-	640 - 1000
Weight	[kg]	14.5	14.5	10.5	10.5	11.8

Main views

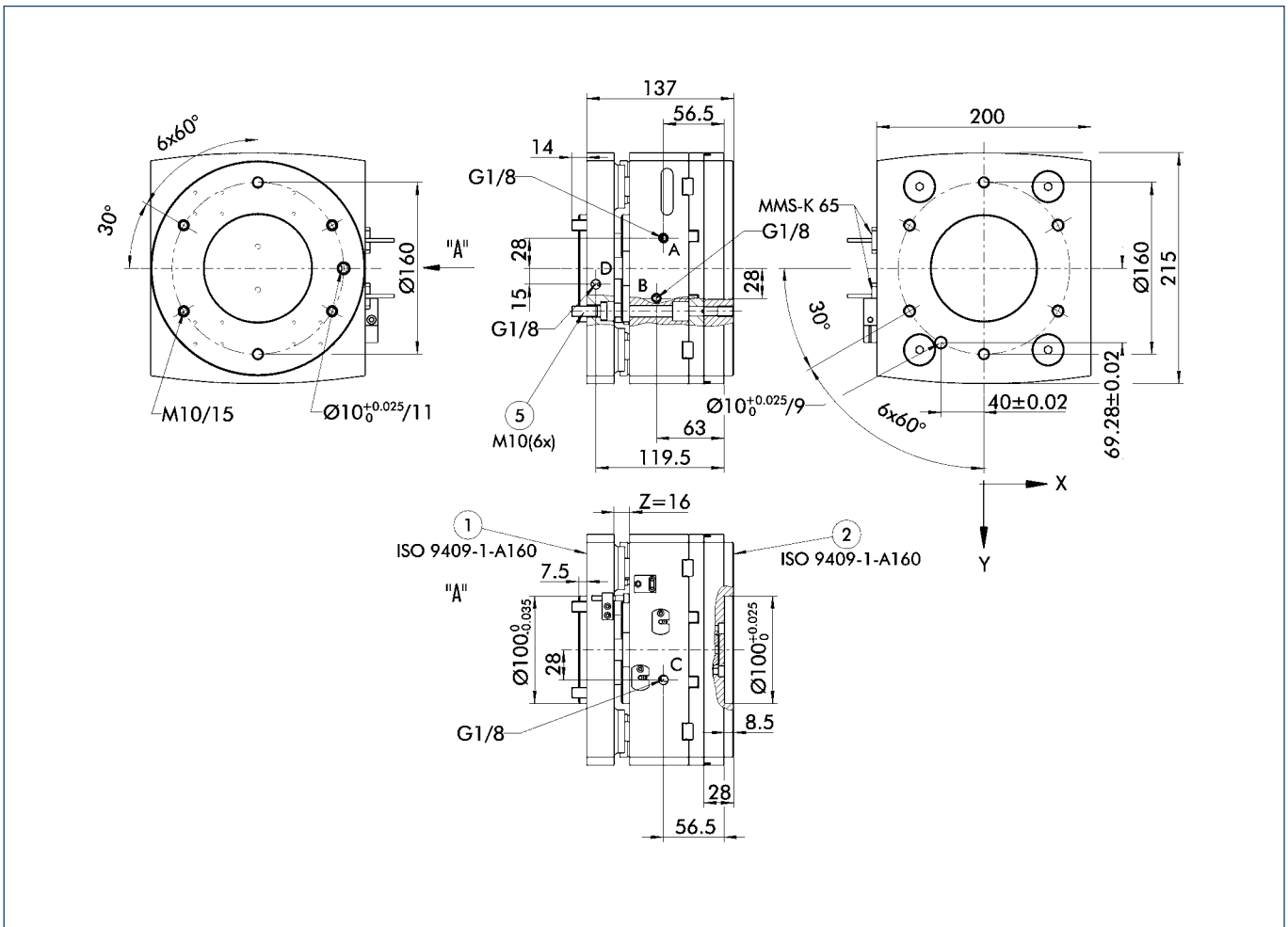

- A Unlocked air connection
- B Locked air connection
- C Air connection position storage XY
- D Locked air connection Z
- ① Robot-side connection
- ② Tool-side connection
- ⑤ Through-bore for screw connection with screw (enclosed)

Change in dimension AGE-S-160-XY

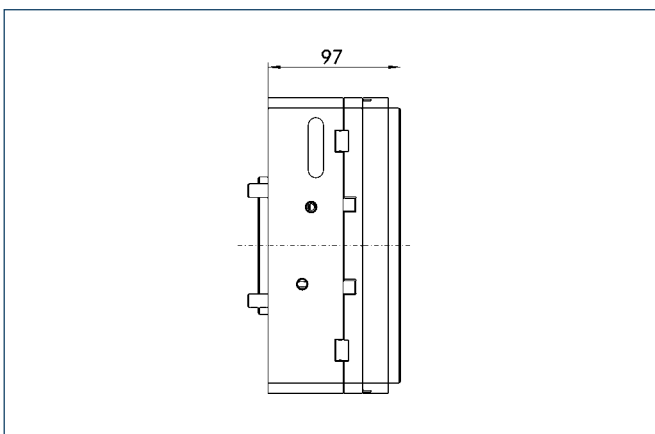

Change in dimension AGE-S-160-Z

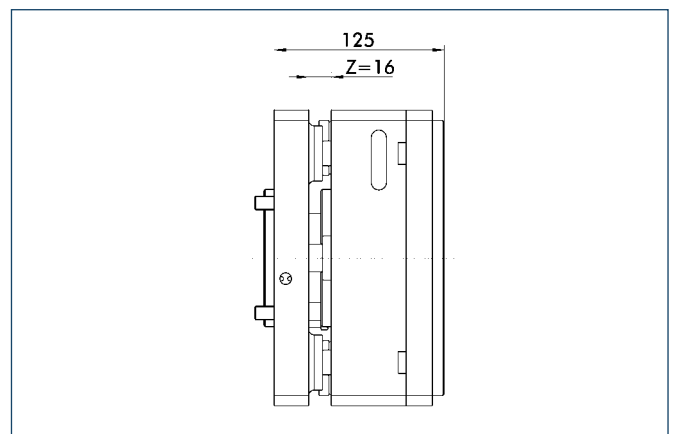

Sensor system

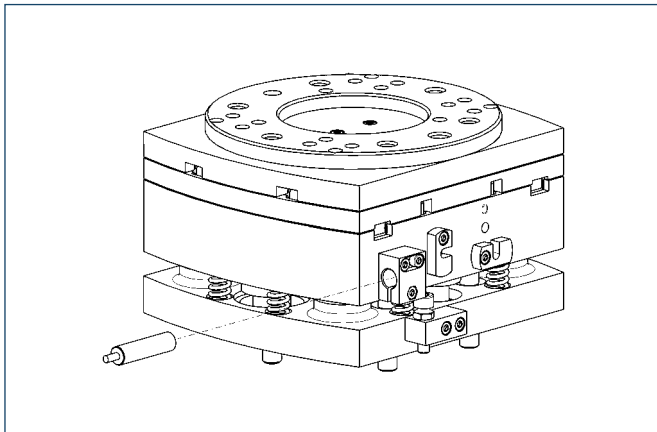

Z stroke monitoring:

Inductive proximity switches, for direct mounting

Designation	ID	Recommended product
IN 80/S-M12	0301578	
IN 80/S-M8	0301478	•
IN-B 80/S-M8	0301477	
INK 80/S	0301550	

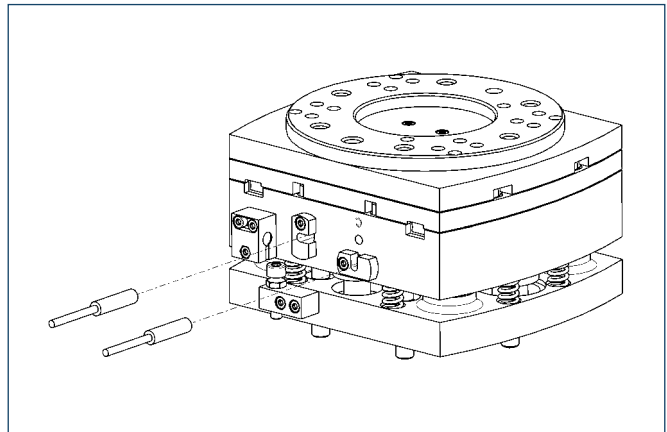

Centric locking monitoring:

Electronic magnetic switch

Designation	ID
MMS-K 65/S-PNP	0301423
MMS-K 65/S NPN	0301424

- ① Two sensors (closers/S) are required for each compensation unit, plus extension cables as an option.

Extension cables for proximity switches/magnetic switches

Designation	ID
GK 3-M8	0301622
GK 3-M5-PNP/NPN	0301652
KV 10-M12	0301596
KV 10-M8	0301496
KV 20-M12	0301597
KV 20-M8	0301497
KV 3-M12	0301595
KV 3-M8	0301495
W 3-M12	0301503
W 5-M12	0301507
W 3-M5-PNP/NPN	0301650
WK 3-M8	0301594
WK 3-M8 NPN	0301602
WK 5-M8	0301502
WK 5-M8 NPN	9641116

- ① Please note the minimum permitted bending radii for the sensor cables, which are generally 35 mm.



You can find more detailed information on, and individual parts for, the above-mentioned accessories in the “Accessories” catalog section.

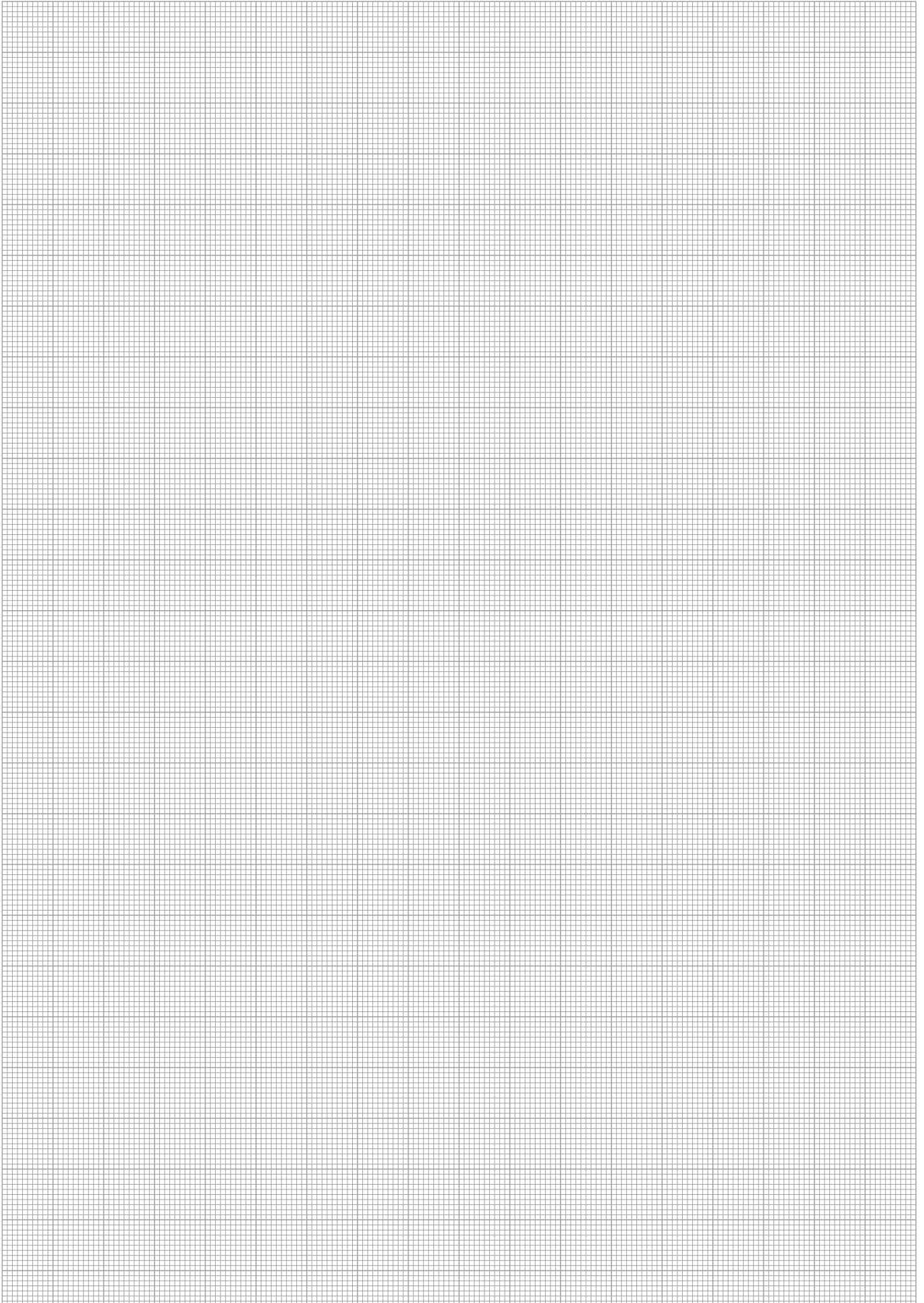



Forces and moments

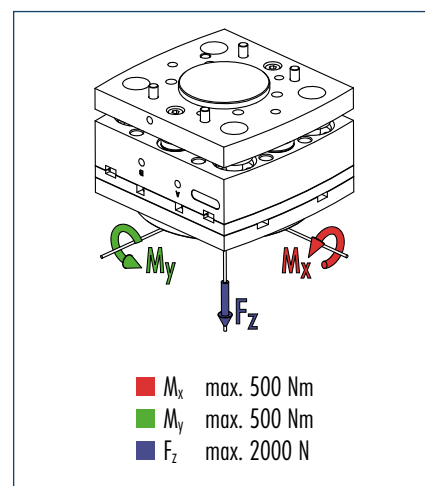

Technical data

Designation		AGE-S-200-XYZ-0	AGE-S-200-XYZ-P	AGE-S-200-XY-0	AGE-S-200-XY-P	AGE-S-200-Z
	ID	0324602	0324604	0324600	0324603	0324601
X/Y stroke	[mm]	± 12	± 12	± 12	± 12	-
Z stroke	[mm]	14	14	-	-	14
Locking force at 6 bar	[N]	2700	2700	2700	2700	-
Max. payload	[kg]	100	100	100	100	100
Position storage force	[N]	-	4500	-	4500	-
Piston force Z	[N]	3000	3000	-	-	3000
Spring force Z	[N]	1100 - 1500	1100 - 1500	-	-	1100 - 1500
Weight	[kg]	29.5	29.5	21.0	21.0	23.5

Main views

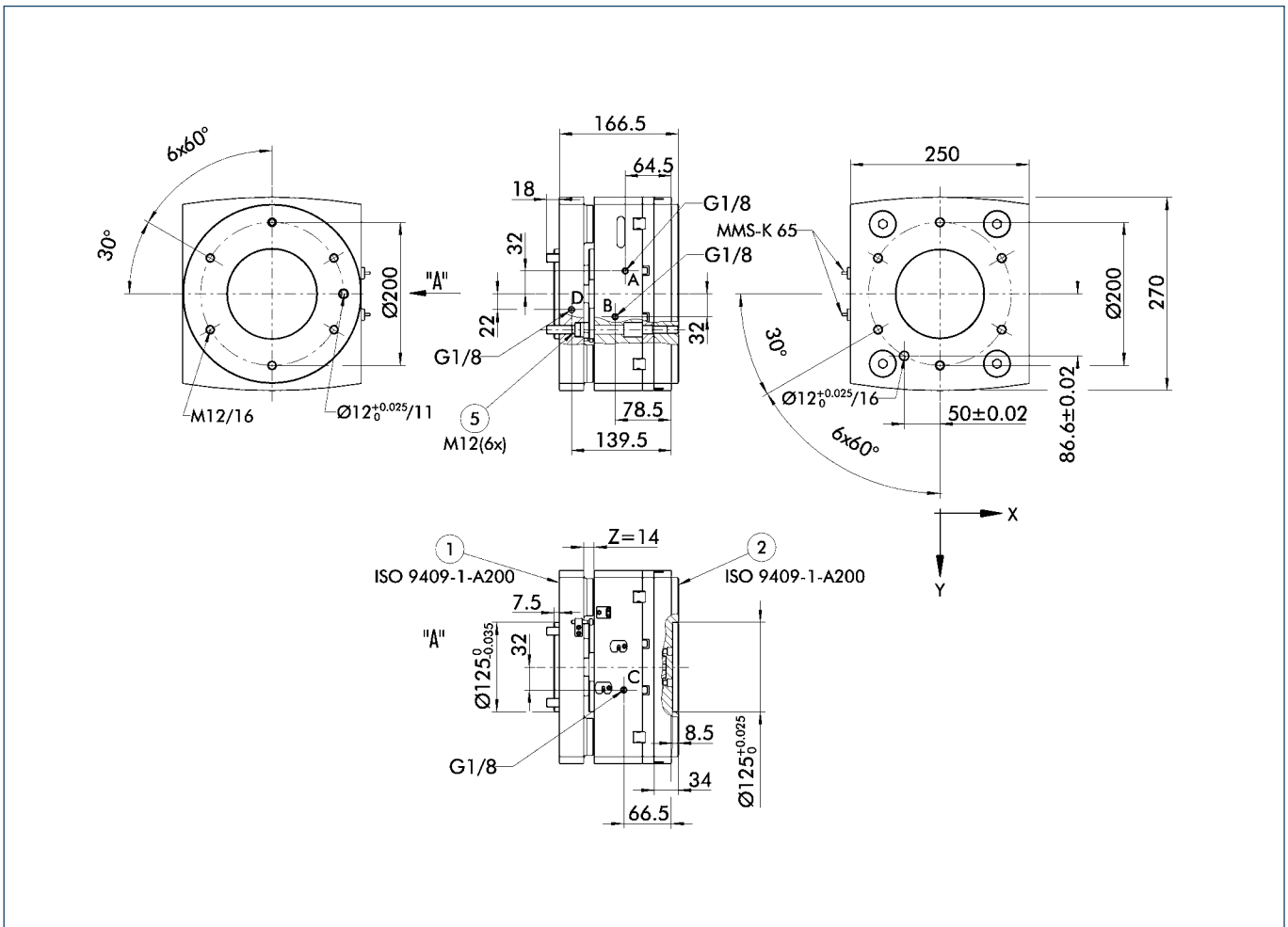

- A Unlocked air connection
- B Locked air connection
- C Air connection position storage XY
- D Locked air connection Z
- ① Robot-side connection
- ② Tool-side connection
- ⑤ Through-bore for screw connection with screw (enclosed)

Change in dimension AGE-S-200-XY

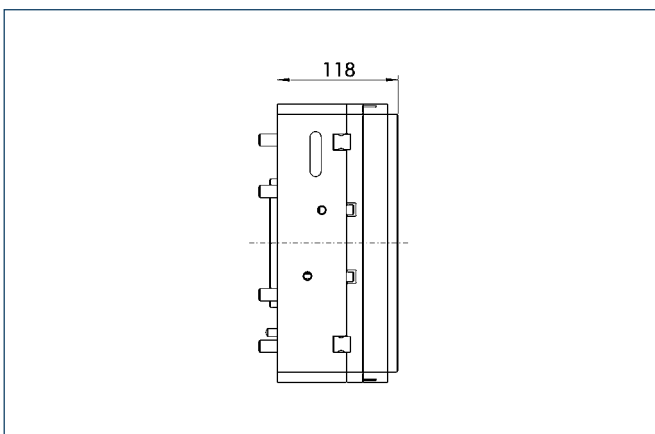

Change in dimension AGE-S-200-Z

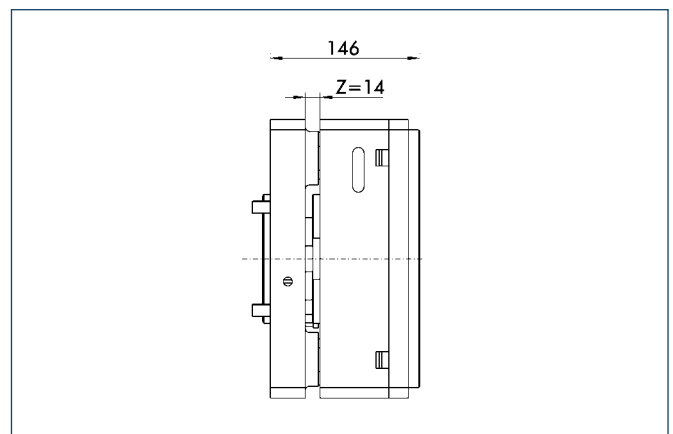

Sensor system

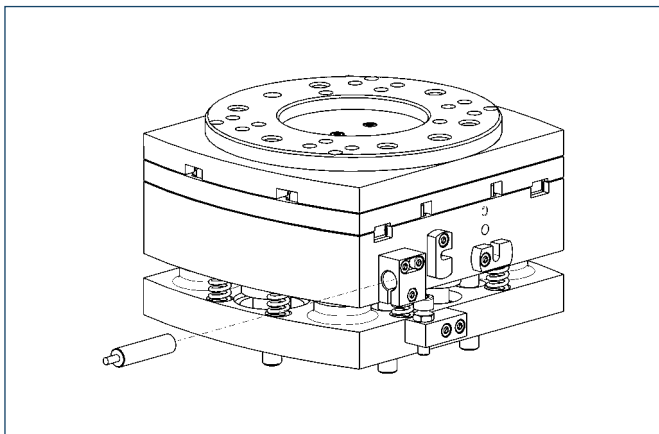

Z stroke monitoring:

Inductive proximity switches, for direct mounting

Designation	ID	Recommended product
IN 80/S-M12	0301578	
IN 80/S-M8	0301478	•
IN-B 80/S-M8	0301477	
INK 80/S	0301550	

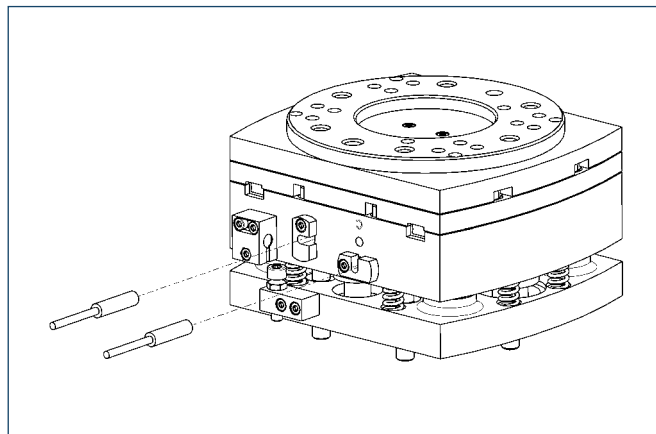

Centric locking monitoring:

Electronic magnetic switch

Designation	ID
MMS-K 65/S-PNP	0301423
MMS-K 65/S NPN	0301424

- ① Two sensors (closers/S) are required for each compensation unit, plus extension cables as an option.

Extension cables for proximity switches/magnetic switches

Designation	ID
GK 3-M8	0301622
GK 3-M5-PNP/NPN	0301652
KV 10-M12	0301596
KV 10-M8	0301496
KV 20-M12	0301597
KV 20-M8	0301497
KV 3-M12	0301595
KV 3-M8	0301495
W 3-M12	0301503
W 5-M12	0301507
W 3-M5-PNP/NPN	0301650
WK 3-M8	0301594
WK 3-M8 NPN	0301602
WK 5-M8	0301502
WK 5-M8 NPN	9641116

- ① Please note the minimum permitted bending radii for the sensor cables, which are generally 35 mm.



You can find more detailed information on, and individual parts for, the above-mentioned accessories in the "Accessories" catalog section.

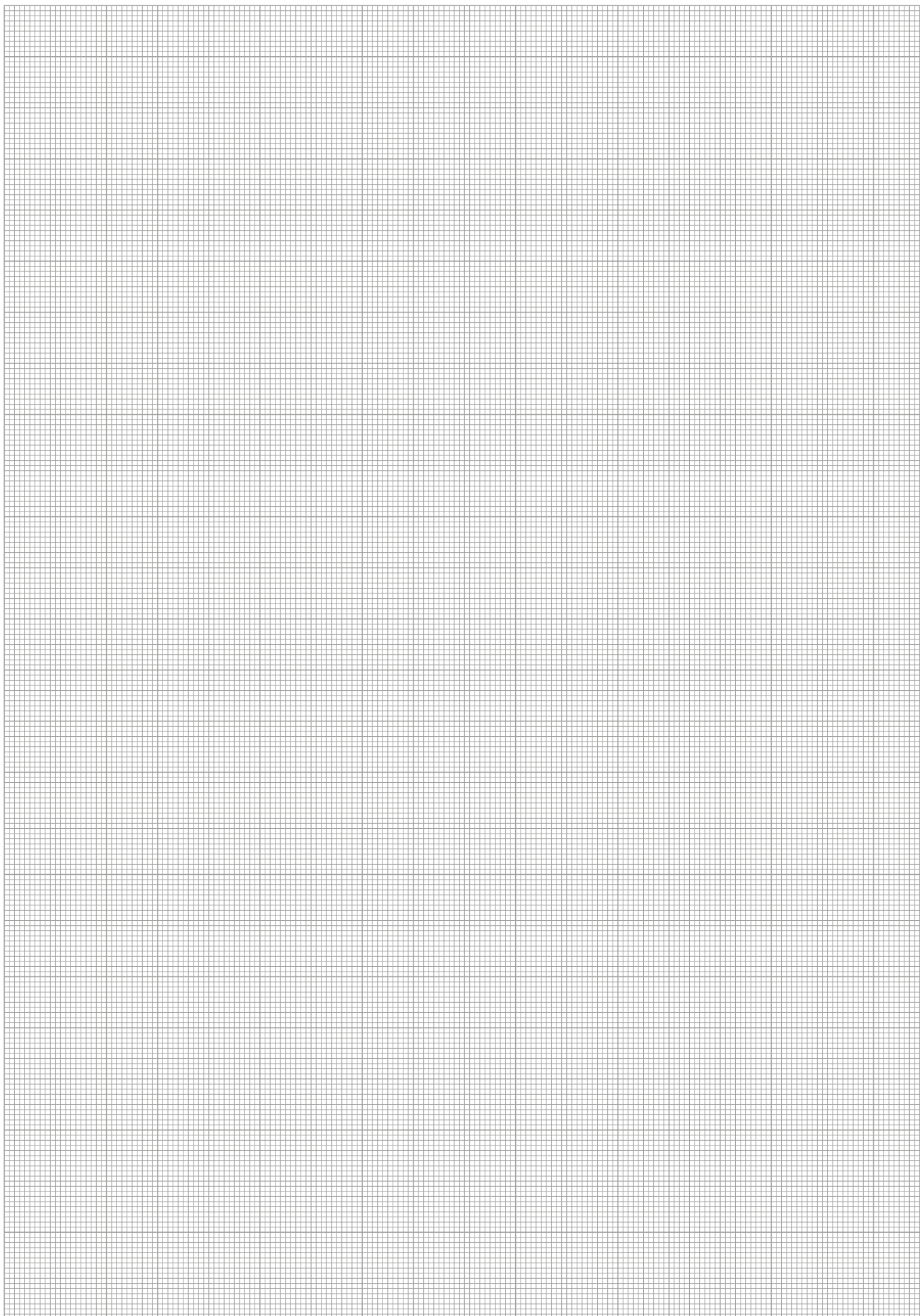



Sizes
01-30 .. 400



Payload
up to 20 kg



Compensation path XY
 ± 2.2 mm



Compensation bend
 1°

Application example

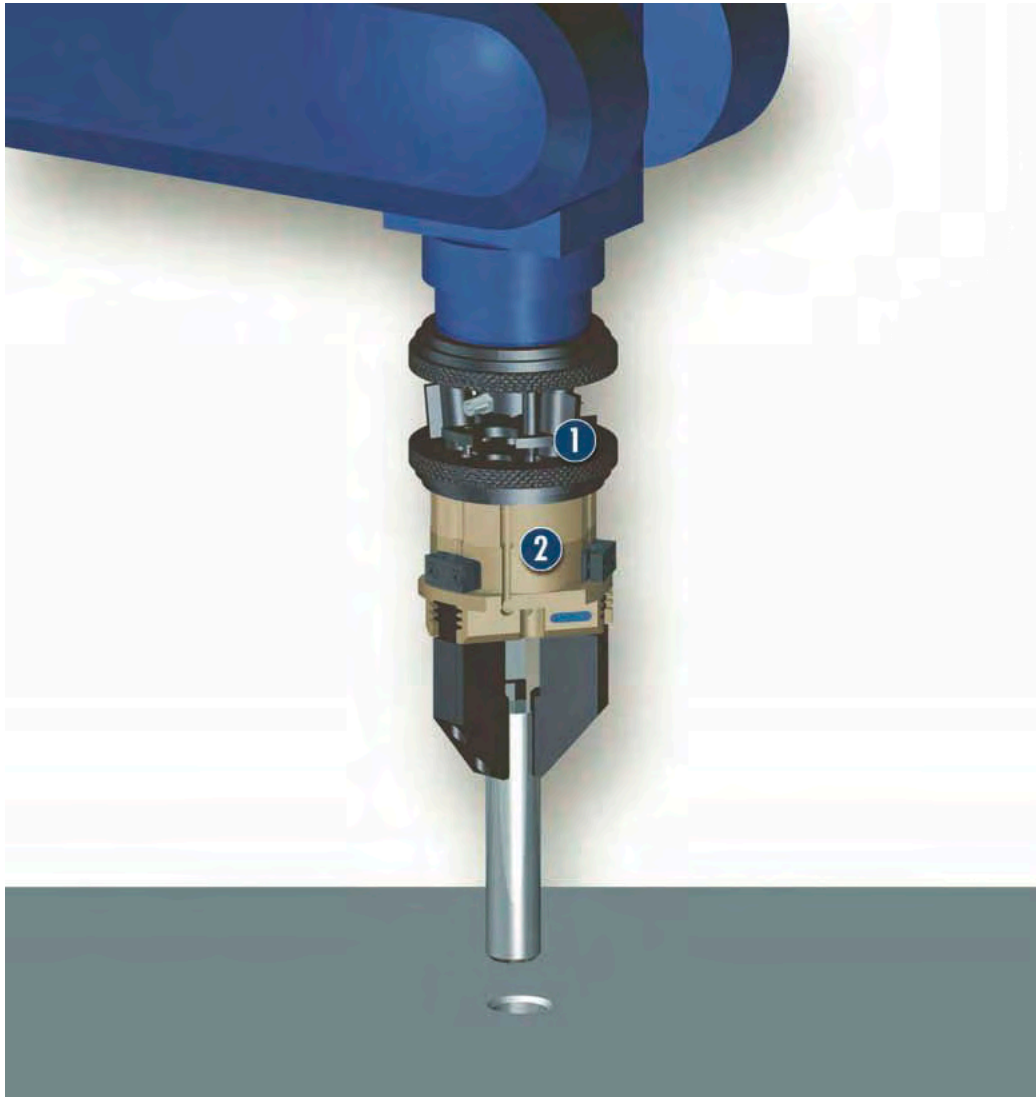

Inserting a bolt into a bore

1 FUS-113B Insertion Unit

2 PZN-plus 80 2-Finger Centric Gripper

Insertion Unit

Symmetrical insertion unit with centric locking and monitoring

Area of application

Assembly tasks with very little play for the parts to be aligned

Your advantages and benefits

Pneumatic, centric locking

resets the unit to a defined zero position and protects the elastomers

Elastomers with layered structure

soft and flexible on insertion and rigid when compressed

Compensates for misalignment

and therefore reduces the risk of jamming



General information on the series

Material

Aluminum, elastomer materials

Maintenance

Maintenance-free

Position during insertion

Vertical

Scope of delivery

Operating manual, maintenance instructions, manufacturer's declaration

Actuation

Pneumatic, dry or lubricated filtered compressed air (10 µm)

Operating pressure

From 5 bar to 6 bar

Connections

Two plug connections for hose with 4.0 mm diameter

Force maintained in the event of a drop in pressure

Possible via SDV-P pressure maintenance valve

Warranty

24 months

Sectional diagram

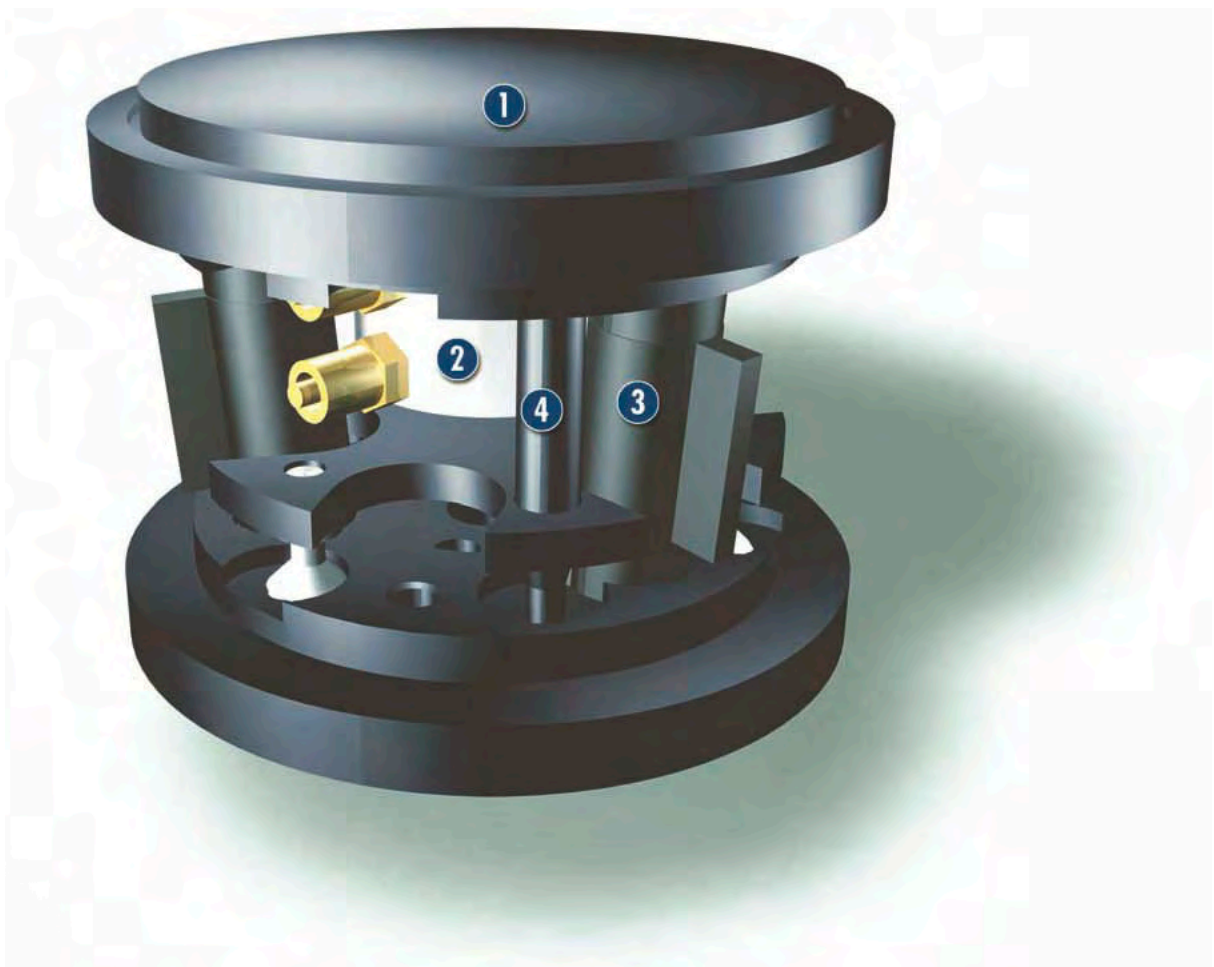

1 Adapter Flange
individual screw connection diagrams can be easily integrated

2 Pneumatic Locking
for a secure connection from the machine and tool sides

3 Elastomers
facilitate the compensation movement

4 Overload Bolt
to protect the elastomers

Accessories

Accessories from SCHUNK – the suitable supplement for maximum functionality, reliability and performance of all automation modules.

IN inductive proximity switches



Fittings



① For the exact size of the accessories, the availability for this size and the designation and ID, please refer to the additional views at the end of the size in question. You can find more detailed information on our accessory range in the “Accessories” catalog section.

General information on the series

Material properties of the shearing cushion

	001-30	001 A	111 B	112 B	113 B	211 A	211 B	211 C	212 A	212 B	212 C	213 A	213 B	213 C	413 C	413 D
ID	320280	320518	320519	320522	320525	320527	320528	320529	320530	320531	320532	320533	320534	320535	320336	320337
ID	320338 320339															
Material	CR	CR	CR	CR	NBR	CR	CR	CR	CR	CR	CR	NBR	NBR	NBR	NBR	NBR
Operating temperature	5-60	5-60	5-60	5-60	5-60	5-60	5-60	5-60	5-60	5-60	5-60	5-60	5-60	5-60	5-60	5-60
Oil resistance	0	0	0	0	++	0	0	0	0	0	0	++	++	++	++	++
Resistance to coolant	0	0	0	0	++	0	0	0	0	0	0	++	++	++	++	++
Resistance to ozone	+	+	+	+	-	+	+	+	+	+	+	-	-	-	-	-

++ = very good + = well-suited 0 = suitable to a limited extent

Checklist for selection of FUS insertion unit to fax no. +49-7133-103-2189

Customer: _____ Order number: _____
 Department: _____
 Contact: _____
 Date: _____
 Telephone: _____
 Fax: _____

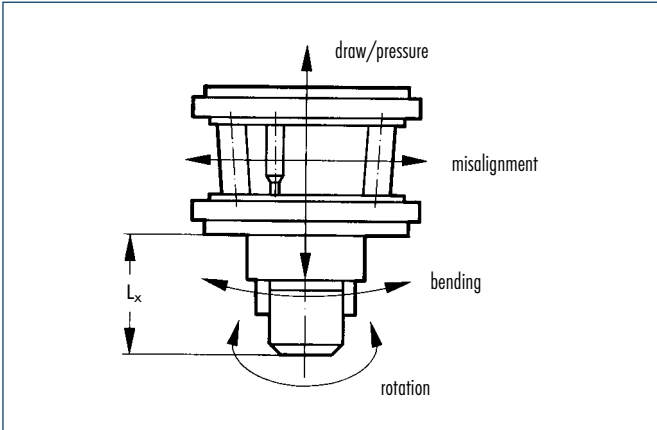

1. Distance of the center of compliance to the FUS in mm: _____
2. Max. offset of the parts to be aligned Displacement: _____ mm
 Tilting: _____ °
 Rotation: _____ °
3. Size of the insert chamfer (chamfer is mandatory) Bolt: _____
 Bore: _____
4. Insertion diameter with tolerance Bolt: _____ mm
 Bore: _____ mm
5. Materials of the parts to be aligned Bolt: _____
 Bore: _____
6. Insertion direction vertical horizontal _____
7. FUS load (tool and workpiece): _____ kg
8. Insertion speed and acceleration: _____
9. Maximum insertion force available: _____ N
10. Environment conditions (coolant, temperature, lubrication of the parts to be aligned, etc.)

11. Pneumatic locking Yes No

Mode of operation of the FUS

The coaxial insertion unit function is based on a set of three to six shearing cushions made from an elastomer material which project an assumed rotation point outside of the system which is also intended to be the compensation point. The compensation center is the center of the rotation and translation movements within the space.

If the compensation center is positioned in the mating surface of the workpiece, the workpiece to be inserted can move and rotate around this center. This reduces the required assembly forces as well as the risk that the parts will jam. Compensation of this kind for positioning errors in transverse and angular direction reduces wear on robots and robotic equipment as well as the need for high-precision machines and devices. The insertion unit is to be aligned vertically. Horizontal use is possible if the load bearing capacity and accuracy are limited.

Advantages

- Compensated positioning error sideways, in the axle angle and angle of rotation
- Rigid in the direction of compression for insertion movements
- Flexible in the compensation direction
- Shearing cushions made from elastomer material facilitate intrinsic damping and self centering
- Mechanical overload bolts protect from overload in all directions
- Various different compensation center distances available for parts of differing size
- Various different elastomer materials for the shearing cushions available for a range of rigidities
- Maintenance-free

Pneumatic locking option

All FUS models are equipped with pneumatic locking.

Operating pressure: 5 bar - 6 bar

Pressure connection: Two plug connections for hose Ø 4.0 mm

Advantages

- Shorter cycle times as vibration is prevented
- Improved repeat accuracy
- Centering of tool and machine side
- Increased shearing cushion life span
- Flexibility can be deactivated
- Locking system does not require additional unit height

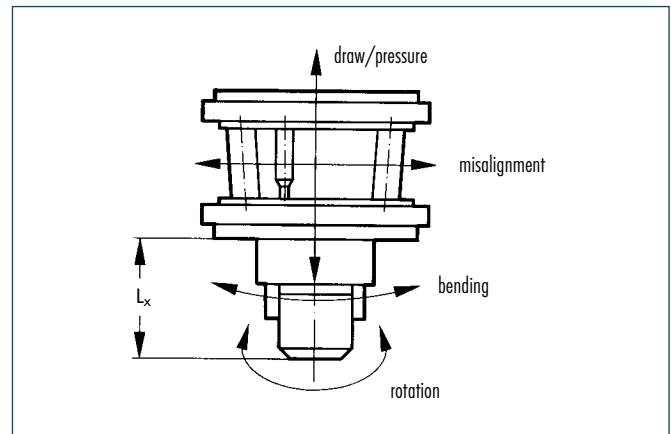



Moment load

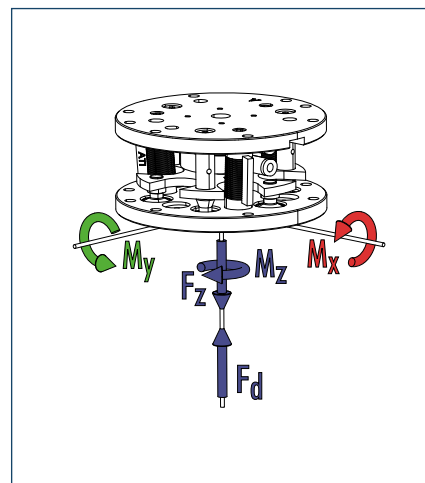

Traction	[N]	9
Pressure	[N]	160
Displacement	[N]	3
Bending	[Nm]	1.1
Rotation	[Nm]	0.1

Technical data

Designation		FUS-001-30
Without locking	ID	0320280
Tension/pressure	[mm]	0.4/0.4
Max. compensation - Displacement	[mm]	± 1.7
Max. compensation - Bending	[°]	1
Rotation	[°]	4.5
Repeat accuracy without locking	[mm]	± 0.05
Rigidity		
Tension/pressure	[N/mm]	385
Displacement	[N/mm]	7.5
Bending	[Nm/rad]	57
Rotation	[Nm/rad]	0.8
Weight without lock	[kg]	0.05

Main views

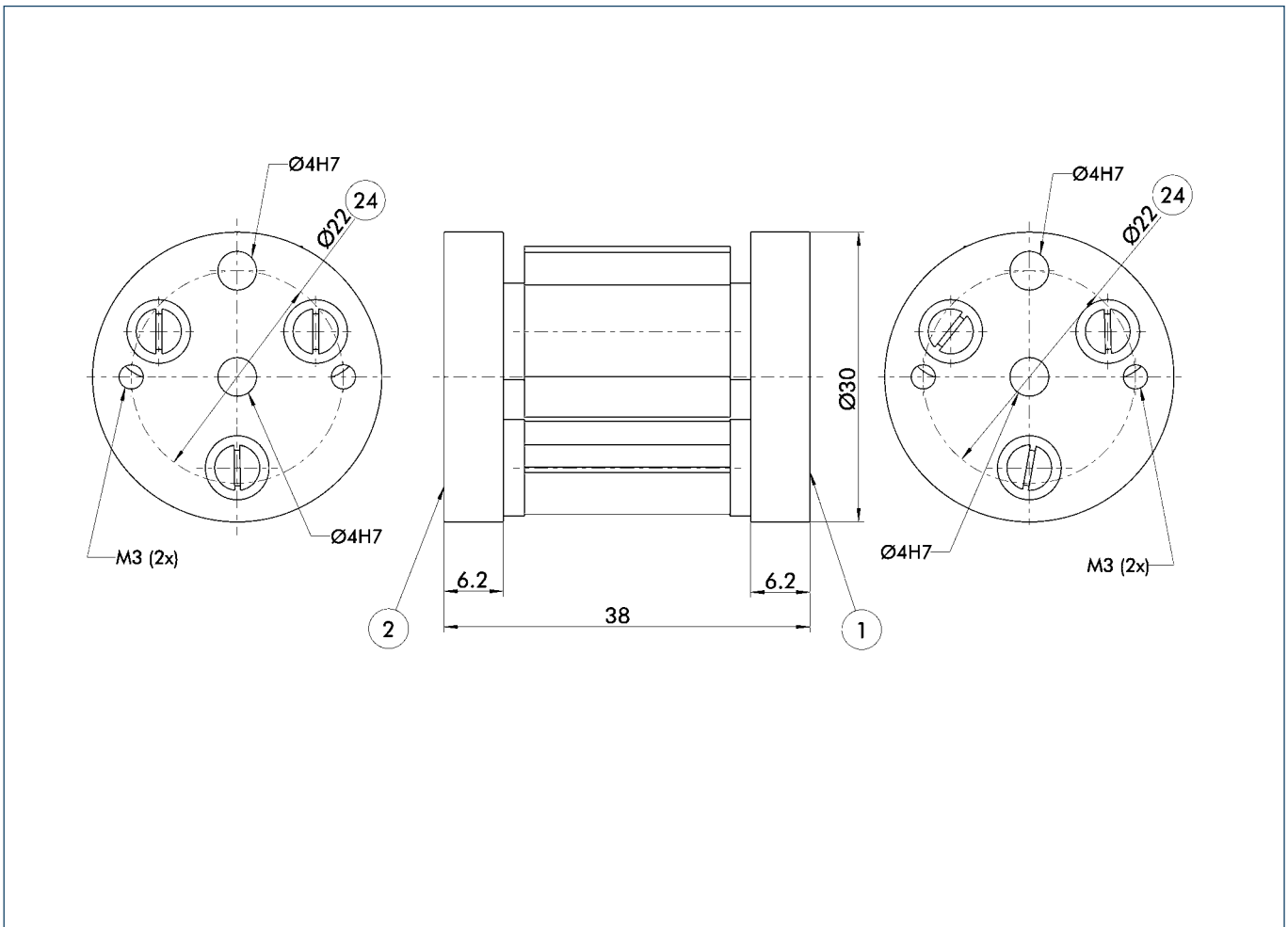

- ① Robot-side connection
- ② Tool-side connection
- ⊘ Bolt pitch circle





Moment load

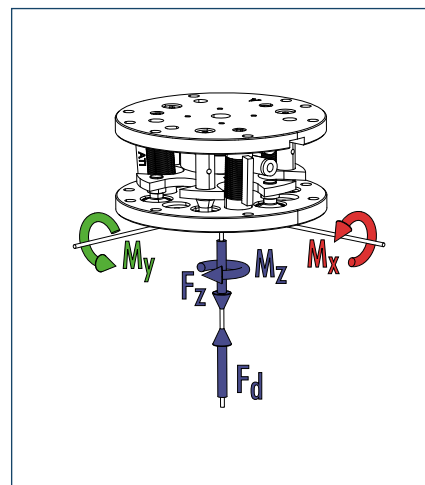

Traction	[N]	22
Pressure	[N]	355
Displacement	[N]	6.5
Bending	[Nm]	3.4

Technical data

Designation		FUS-001
With locking mechanism	ID	0320518
Max. compensation - Displacement	[mm]	± 1.7
Max. compensation - Bending	[°]	1
Rotation	[°]	4.5
Rigidity		
Displacement	[N/mm]	1.7
Bending	[Nm/rad]	180
Compensation center clearance L_0	[mm]	23
Weight with lock	[kg]	0.18

Main views dimensions

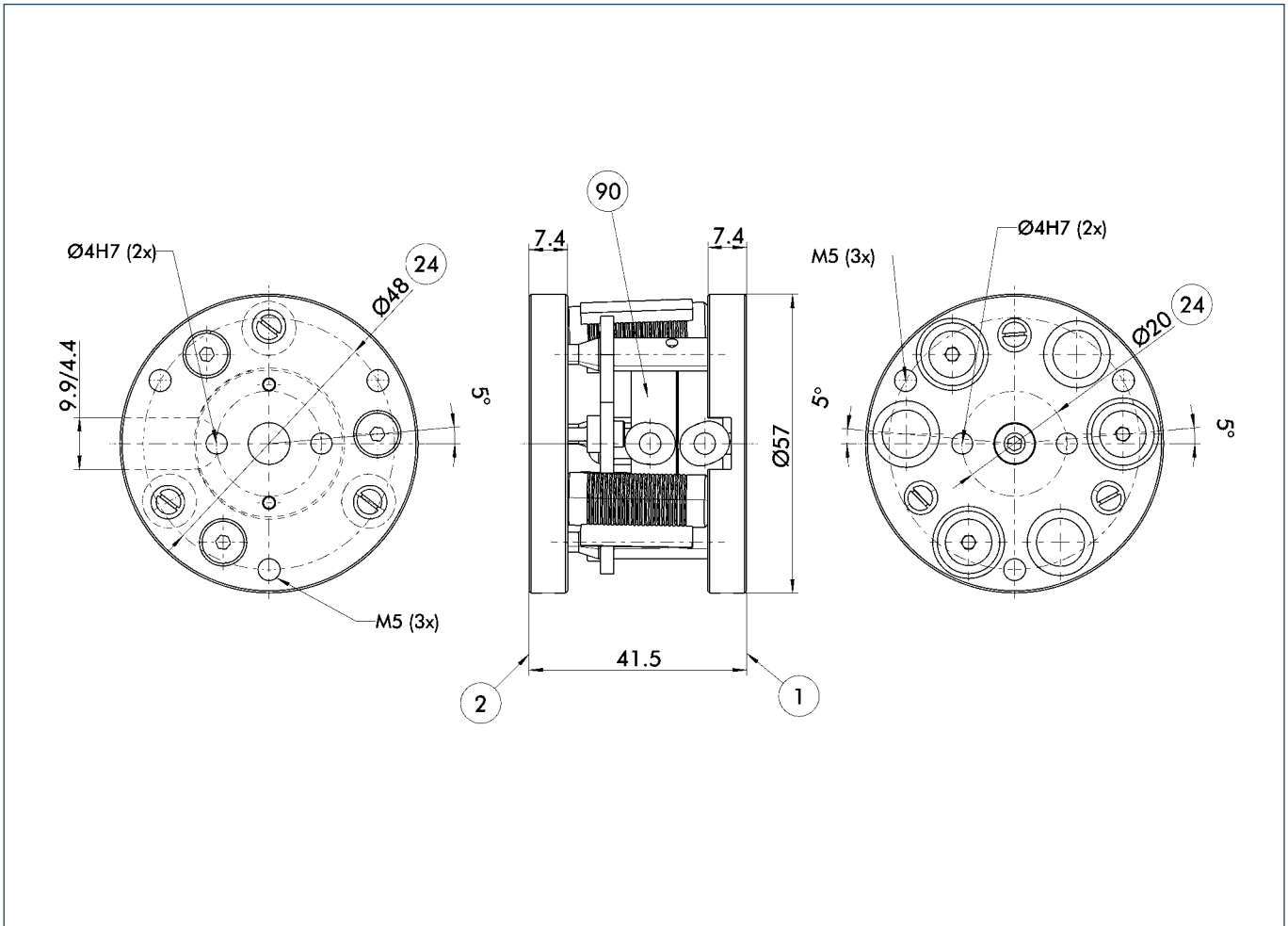

- ① Robot-side connection
- ② Tool-side connection
- ②④ Bolt pitch circle
- ⑨⑩ Pneumatic locking

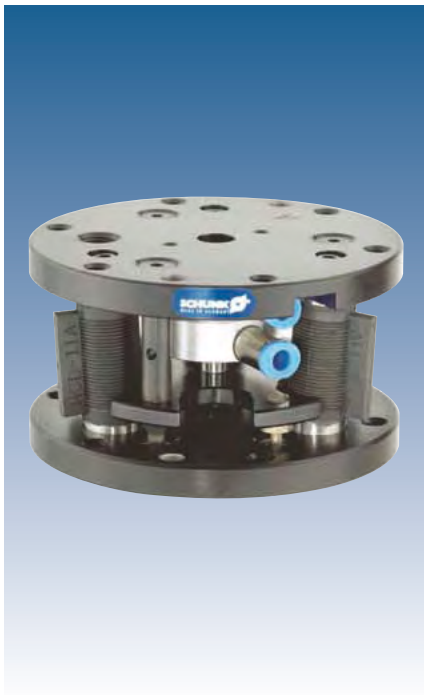

Moment load

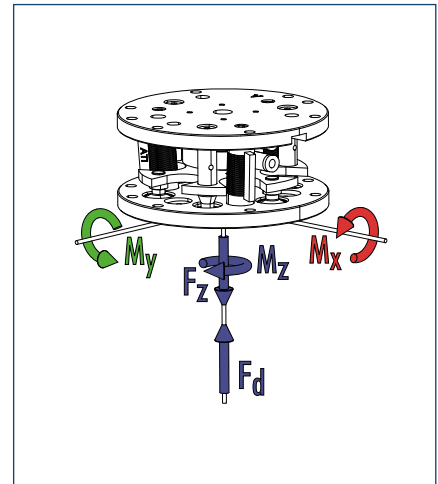

Designation	FUS-111B	FUS-112B	FUS-113B	
Traction	[N]	45	45	82
Pressure	[N]	1290	540	1290
Displacement	[N]	9	9	27
Bending	[Nm]	5.2	5.2	8

Technical data

Designation		FUS-111 B	FUS-112 B	FUS-113 B
With locking mechanism	ID	0320519	0320522	0320525
Max. compensation - Displacement	[mm]	± 2.2	± 2.2	± 2.2
Max. compensation - Bending	[°]	1.1	1.1	1.1
Rotation	[°]	5	5	5
Rigidity				
Displacement	[N/mm]	11	7	27
Bending	[Nm/rad]	380	180	640
Compensation center clearance L_0	[mm]	118	64	57
Weight with lock	[kg]	0.31	0.31	0.31

Main views

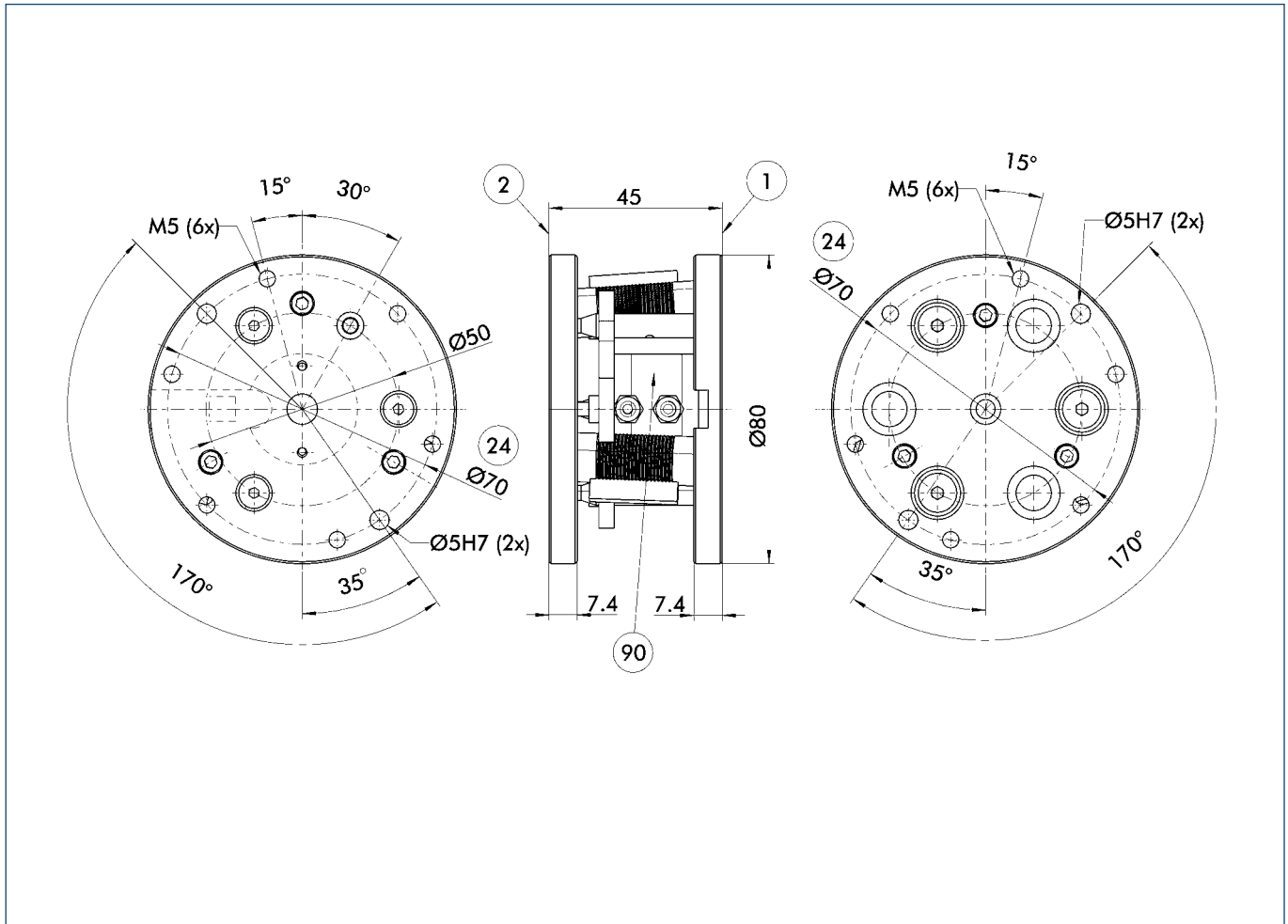

- $\textcircled{1}$ Robot-side connection
- $\textcircled{2}$ Tool-side connection
- $\textcircled{24}$ Bolt pitch circle
- $\textcircled{90}$ Pneumatic locking

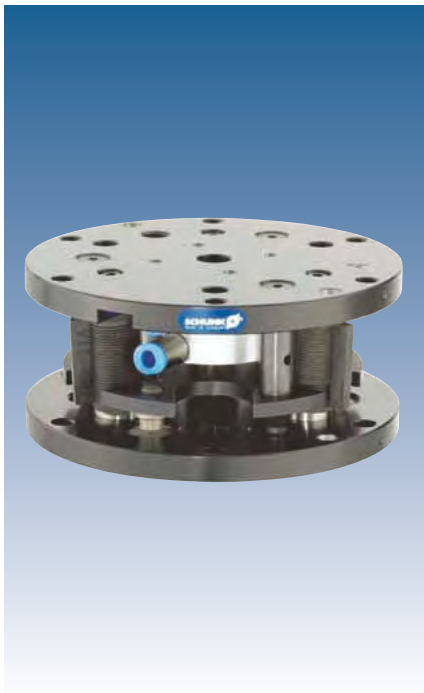

Moment load

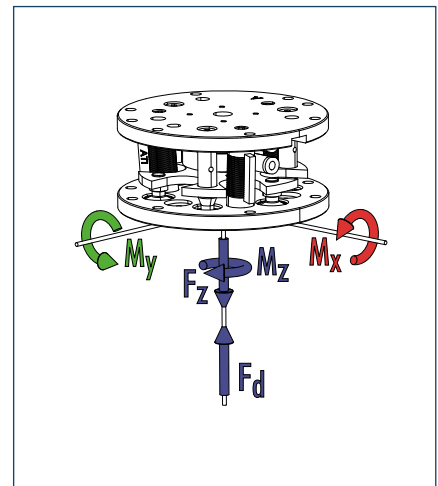

Designation		FUS-211A	FUS-211B	FUS-211C	FUS-212A	FUS-212B	FUS-212C	FUS-213A	FUS-213B	FUS-213C
Traction	[N]	53	53	106	62	62	124	98	98	196
Pressure	[N]	1360	1410	2770	640	730	1360	1360	1400	2770
Displacement	[N]	9	9	18	9	9	18	27	27	54
Bending	[Nm]	6.8	7.3	14.1	6.8	7.3	14.1	8.5	9	17.5

Technical data

Designation		FUS-211A	FUS-211B	FUS-211C	FUS-212A	FUS-212B	FUS-212C	FUS-213A	FUS-213B	FUS-213C
With locking mechanism	ID	0320527	0320528	0320529	0320530	0320531	0320532	0320533	0320534	0320535
Max. compensation - Displacement	[mm]	± 2.2	± 2.2	± 2.2	± 2.2	± 2.2	± 2.2	± 2.2	± 2.2	± 2.2
Max. compensation - Bending	[°]	1.1	1.1	1.1	1.1	1.1	1.1	1.1	1.1	1.1
Rotation	[°]	4	4	4	4	4	4	4	4	4
Rigidity										
Displacement	[N/mm]	11	11	23	7	7	14	26	26	52
Bending	[Nm/rad]	474	552	1025	225	270	495	790	945	1735
Compensation center clearance L_0	[mm]	140	155	148	82	92	87	74	82	79
Weight with lock	[kg]	0.5	0.5	0.5	0.5	0.5	0.5	0.5	0.5	0.5

A = 3 elastomers on inner graduated circle B = 3 elastomers on outer graduated circle C = 6 elastomers

Main views

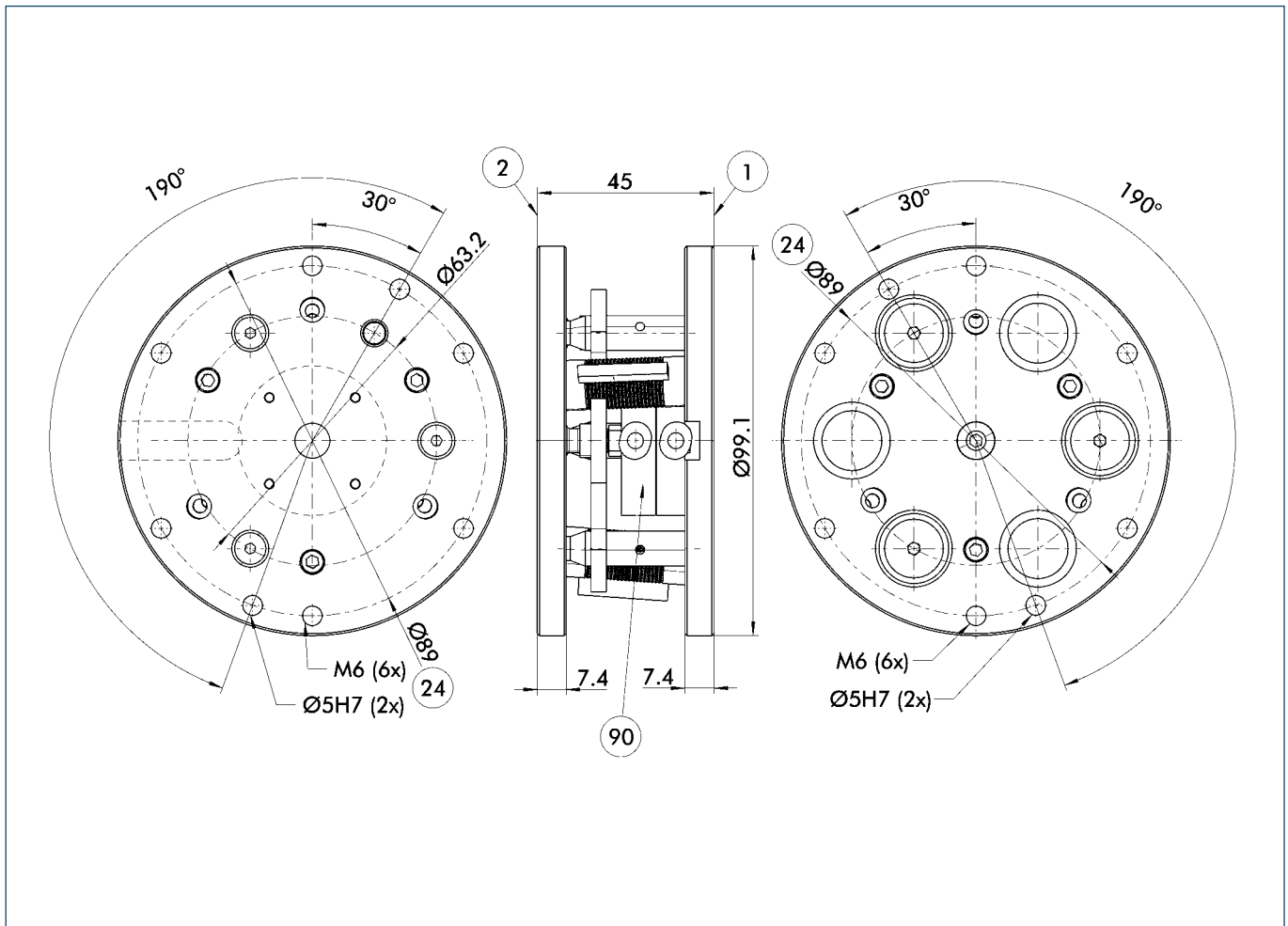

- ① Robot-side connection
- ② Tool-side connection
- ②④ Bolt pitch circle
- ⑨⑩ Pneumatic locking



Moment load

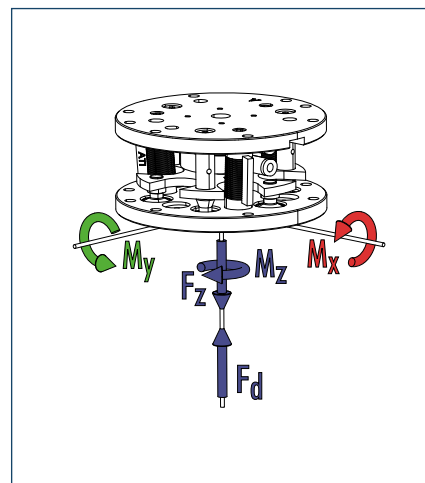

Designation		FUS-413 C	FUS-413 D
Traction	[N]	200	395
Pressure	[N]	2750	5490
Displacement	[N]	27	54
Bending	[Nm]	22.6	45.2
Rotation	[Nm]	33	66

Technical data

Designation		FUS-413 C	FUS-413 D
With locking mechanism	ID	0320338	0320339
Tension/pressure	[mm]	1.1/1.3	1.1/1.3
Max. compensation - Displacement	[mm]	± 2.2	± 2.2
Max. compensation - Bending	[°]	1	1
Rotation	[°]	2.5	2.5
Repeat accuracy without locking	[mm]	± 0.05	± 0.05
Repeat accuracy with locking	[mm]	± 0.01	± 0.01
Rigidity			
Tension/pressure	[N/mm]	6300	12600
Displacement	[N/mm]	60	120
Bending	[N/rad]	9000	1800
Rotation	[N/rad]	330	660
Compensation center clearance L_0	[mm]	225	225
Weight without lock	[kg]	1.1	1.3
Weight with lock	[kg]	1.6	1.8

Main views dimensions with locking mechanism

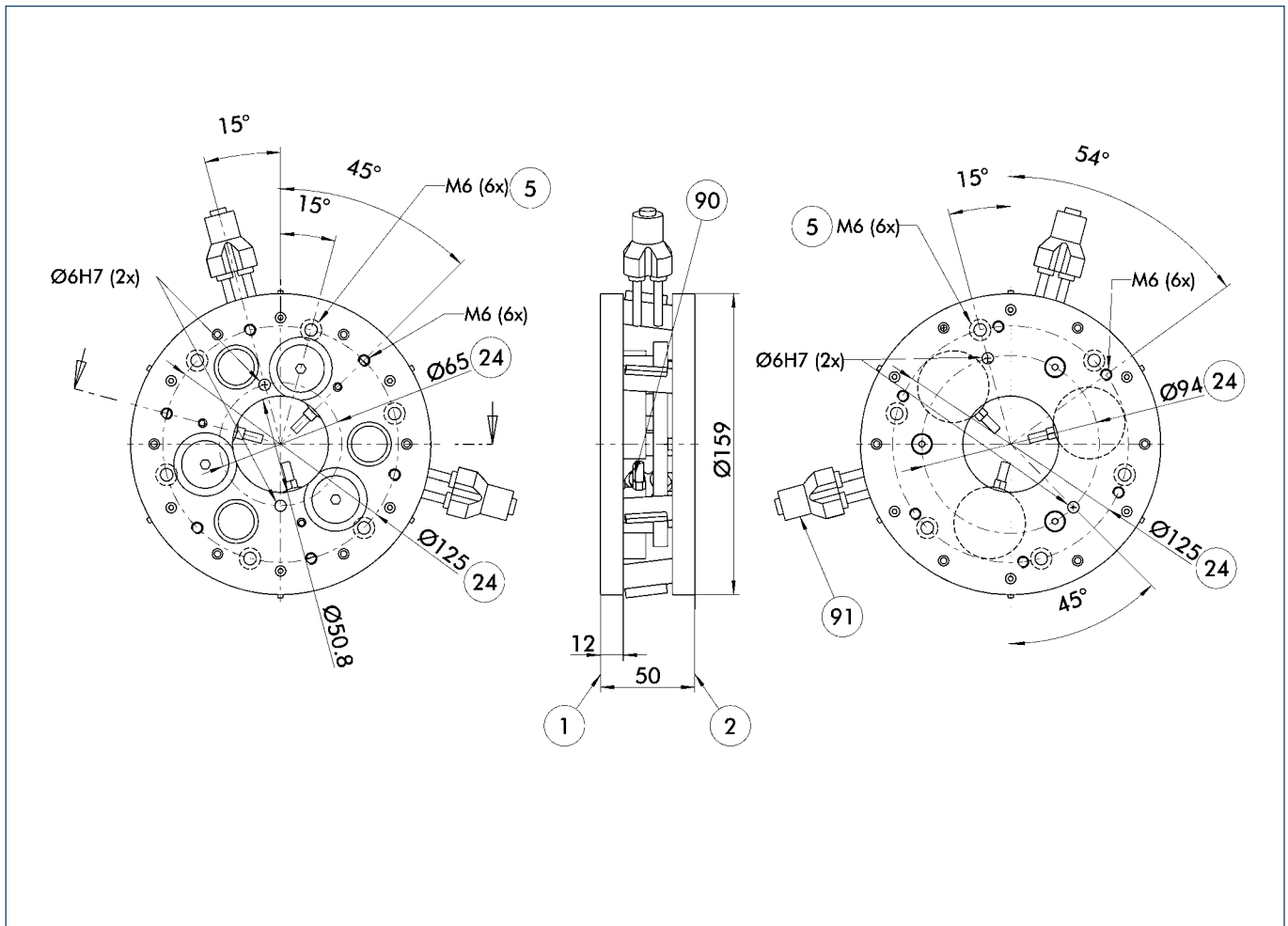

- | | |
|---|--|
| ① Robot-side connection | ⑨⑩ "Lock" and "Unlock" connections |
| ② Tool-side connection | ⑨① Plug connection for hose $\text{Ø} 4$ (2x) supplied as standard |
| ⑤ Through-bore for screw connection with screw (enclosed) | |
| ②④ Bolt pitch circle | |

Measuring



MEASURING

Series	Size	Page
Force Sensors		
FTC		400
FTC	050	404
FTCL	050	406
FT		408
FT-Nano	17	416
FT-Nano	25	418
FT-Nano	43	420
FT-Mini	40	422
FT-Mini	45	424
FT-Gamma		426
FT-Delta		428
FT-Theta		430
FT-Omega	160	432
FT-Omega	190	434
FT-Omega	250	436





Size
050



Range of measurement,
force
± 300 N



Range of measurement,
moments
± 15 Nm

Application example



Robot-supported insertion of a metal pin into
a bore

- 1 FTC-050-80 Force-torque Sensor
- 2 PZN-plus 100
3-Finger Centric Gripper with
workpiece-specific gripper fingers

Force Sensor

Flexible force-torque sensor for compensating for the workpiece's or tool's component tolerances and positioning inaccuracy

Area of application

For insertion operations or for other assembly operations (pressing-in, adhesion or buffing tasks etc.). In the case of handling tasks in particular, the sensitive collision monitoring system helps to protect the tool as well as the workpiece.

Your advantages and benefits

Measuring the forces and moments [N and Nm]

in all six degrees of freedom

Deflection measurement [mm and degrees]

in all six degrees of freedom

Easy connection to a control system

for the lowest possible assembly and start-up costs

Flexibility up to 1.4 mm and 1.4°

for increased operational safety

Symmetrical measurement cell alignment

for efficient calculation of the tool center point displacement with optimum calculating time

Status display via LED

for checking the operating status directly at the sensor

Mechanical overload protection

to protect the sensor



General information on the series

Material

High-strength, hard-coated aluminum alloy

Scope of delivery

Sensor, software for PC connection, installation connector, operating manual, maintenance instructions, manufacturer's declaration

Accessories

Adapter cable, extension cable for CAN and RS-232 on request

Warranty

24 months

Data interface

CAN from 10 Kbaud to 1 Mbaud (DeviceNET on request)
RS-232 1200 Baud to 115200 Baud, RS-485 (on request)

Data update rates

Updating the measurement data: 1 ms
Shortest response time < 200 µs at 1 Mbaud (CAN)

Software

Test software for monitoring all functionalities and for commissioning, based on Agilent Vee. Compatible with Win 9x, Win NT, Win 2000 and Win XP.

Power connection

8-pin circular connector, cable length 300 mm

Sectional diagram

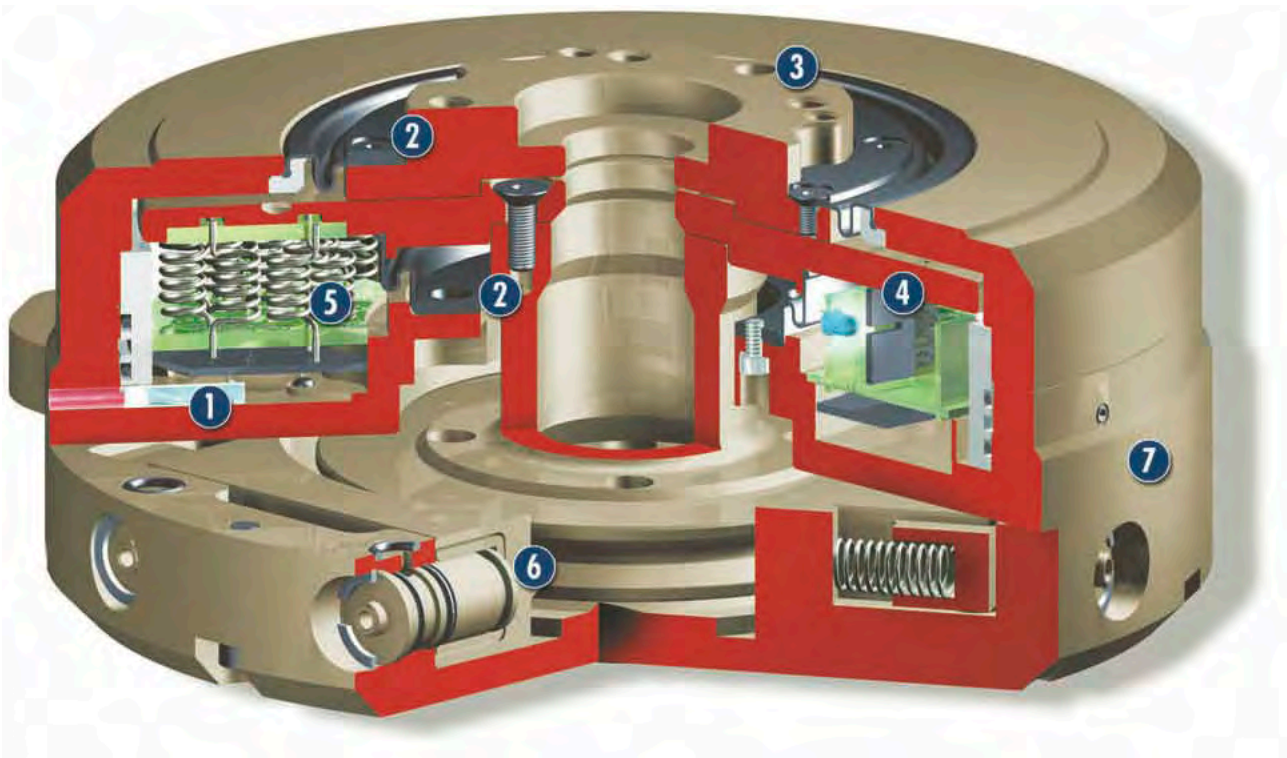

- 1 Optical Fibers**
for displaying the operating status
- 2 Bellow Seal**
for protecting against coarse dirt
- 3 Direct Mounting**
by means of standardized ISO 9409 interface
for robots
- 4 Optical Force/Torque Sensor System
Controller**
to determine the loads applied
- 5 Spring Elements**
to achieve a defined degree of rigidity
- 6 Locking Mechanism**
centric locking with defined flexibility;
pneumatic drive
- 7 Housing**
weight-reduced through the use of a hard-
anodized, high-strength aluminum alloy

Function description

The FTC force-torque sensor is a combination of mechanical flexibility and an opto-electronic position measuring system for all six degrees of freedom. The flexibility prevents an erratic increase in the measurement values in the event of contact and therefore facilitates force-controlled assembly operations with the least possible lag. By means of four, high-speed DSP measurement cells, the sensor measures the displacement of two plates positioned one above the other. Spring elements connect the plates, and forces and moments are calculated from the displacements using a rigidity matrix.

The symmetrical alignment of the measurement cells ensures that the stresses in all six degrees of freedom and the displacement of the tool center point can be calculated efficiently, with optimum calculating time. The robot can be steered and controlled quickly and in real time, thanks to measurement value output at intervals of 1kHz.

Accessories

Accessories from SCHUNK – the suitable supplement for maximum functionality, reliability and performance of all automation modules.

Fittings



Extension cables



Adapter plates

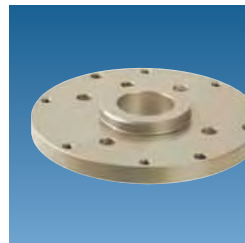

① For the exact size of the accessories, the availability for this size and the designation and ID, please refer to the additional views at the end of the size in question. You can find more detailed information on our accessory range in the “Accessories” catalog section.

General information on the series

Programming

Set commands, Get commands, Info commands
All the functions can be triggered by means of simple character transfer. Therefore a driver is not needed. Integration into any software is possible.

Remote maintenance

PC with sensor (client) and remote maintenance PC (master) must be connected to the internet, and the software (supplied as standard) must be activated on each PC.
Web server solution on request.

Connection

Connection by means of inputs and outputs on request. Monitoring and teaching of all limit values by means of digital input (DI) and digital output (DO) on the customer’s control system. A separate module is needed for this.

Measuring accuracy

5 % along the main axes for deflection up to ± 1 mm and ± 1 degree.

Forces and moments



	FTC-050-80	FTC-050-40
■ F_x	max. 300 N	max. 150 N
■ F_y	max. 300 N	max. 150 N
■ F_z	max. 300 N	max. 150 N
■ M_x	max. 7 Nm	max. 4 Nm
■ M_y	max. 7 Nm	max. 4 Nm
■ M_z	max. 15 Nm	max. 8 Nm

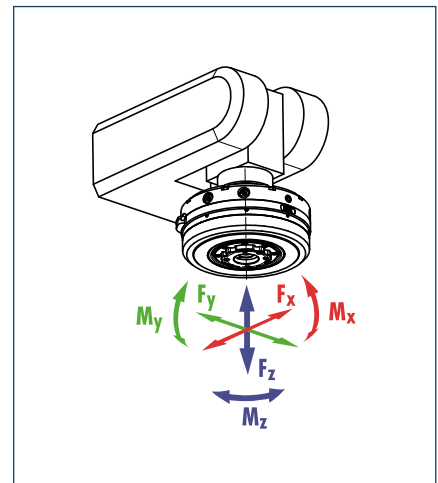

ⓘ In all six degrees of freedom overloads to the specified values are permitted without the sensor being damaged. Permissible external forces and moments in the event that the max. possible motion range of the tool-side flange is exceeded. System butts up to internal stops. If the specified external forces/moments are exceeded, the locking mechanism will be released in the opposite direction to the actuating pressure.

Technical data

Designation		FTC-050-80	FTC-050-80-V	FTC-050-40	FTC-050-40-V
	ID	0322300	0322301	0322302	0322303
Range of measurement, deflection					
Translatory X, Y, Z	[mm]	± 1.0	± 1.0	± 1.0	± 1.0
Rotational α, β, γ	[°]	± 1.0	± 1.0	± 1.0	± 1.0
Area of motion					
Translatory X, Y, Z	[mm]	± 1.4	± 1.4	± 1.4	± 1.4
Rotational α, β, γ	[°]	± 1.4	± 1.4	± 1.4	± 1.4
Overload					
F_x, F_y	[N]	400	400	200	200
F_z	[N]	350	350	180	180
M_x, M_y	[Nm]	14	14	8	8
M_z	[Nm]	25	25	13	13
Locking at 6 bar					
F_x, F_y	[N]	450	450	200	200
F_z	[N]	400	450	230	230
M_x, M_y	[Nm]	20	20	12	12
M_z	[Nm]	35	35	20	20
Robot-side interfaces		ISO 9409-1-A50			
Tool-side interfaces		ISO 9409-1-A50 as well as for gripper model PZN 64			
Mass moment of inertia I_{xx}, I_{yy}	[kg cm ²]	39.5	85.6	39.5	85.6
Mass moment of inertia I_{zz}	[kg cm ²]	58.0	93.7	58.0	93.7
Weight	[kg]	1.56	2.56	1.56	2.56
Min. ambient temperature	[°C]	5	5	5	5
Max. ambient temperature	[°C]	55	55	55	55
Power supply	[VDC]	10 - 26	10 - 26	10 - 26	10 - 26
Power consumption	[W]	1.8	1.8	1.8	1.8
IP rating		65	65	65	65

ⓘ Sensor FTC-050 with variable rigidity (80) and (40) springs, sensor FTC-050-XX with pneumatic, single-acting locking system (V), sensor FTC-L050 light-weight version with variable rigidity (80) and (40) springs.

Main views FTC-050

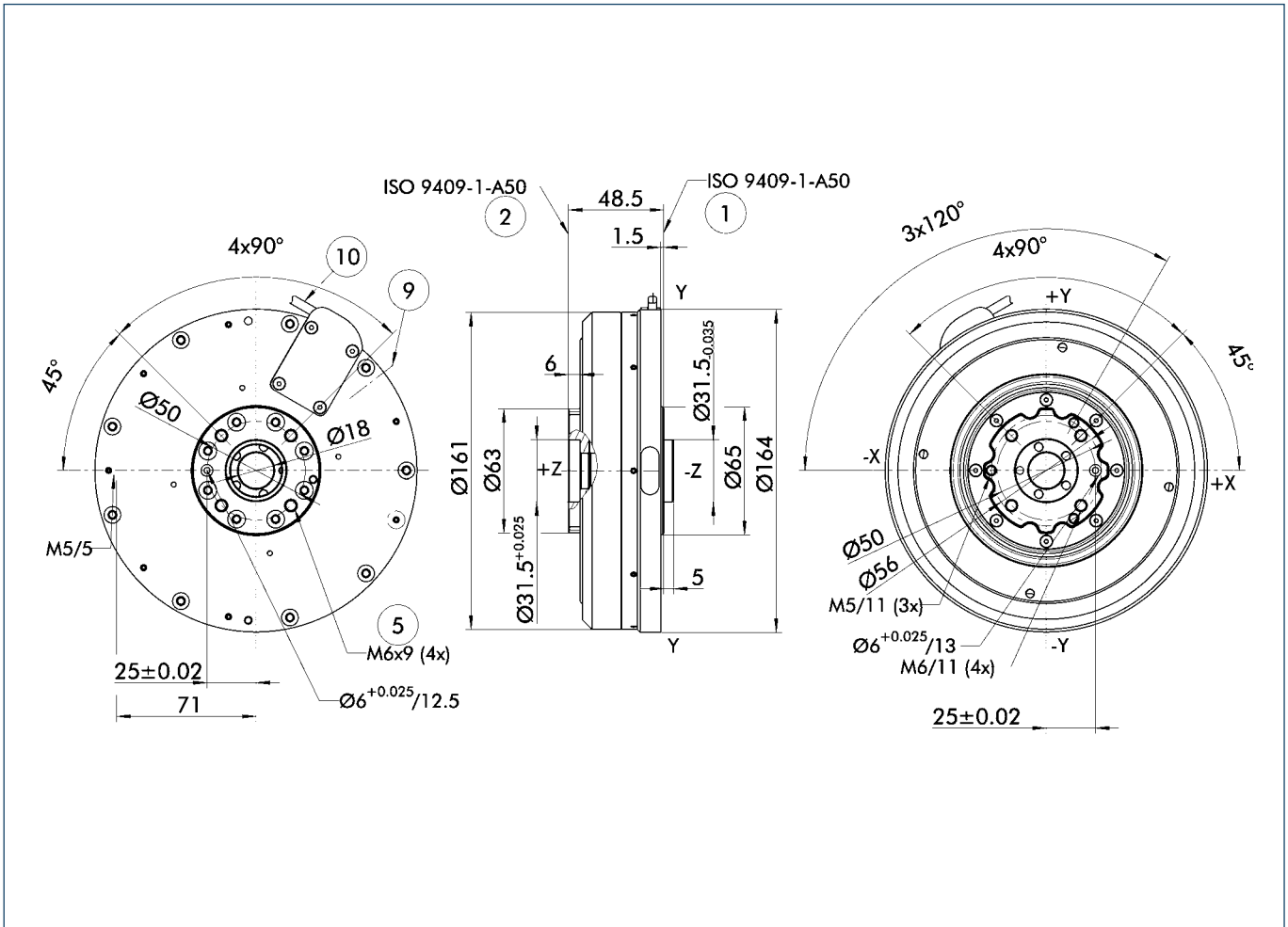

- ① Robot-side connection
- ② Tool-side connection
- ⑤ Through-bore for screw connection with screw (enclosed)
- ⑨ Status display
- ⑩ Connection cable

Dimensions for FTC-050 with lock

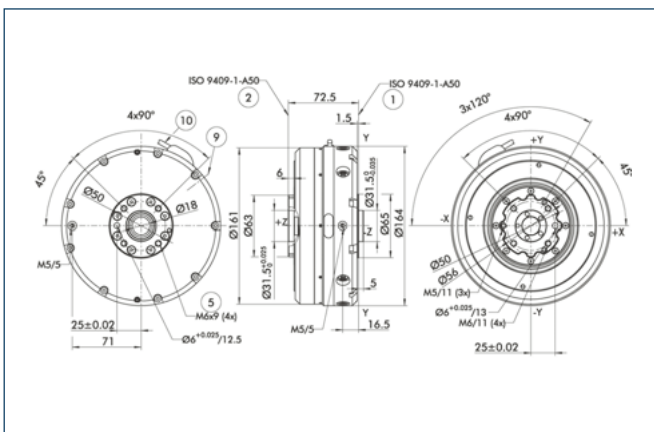

- ① Robot-side connection
- ② Tool-side connection
- ⑤ Through-bore for screw connection with screw (enclosed)
- ⑨ Status display
- ⑩ Connection cable

Forces and moments



	FTCL-050-80	FTCL-050-40
■ F_x max. 300 N	max. 300 N	max. 150 N
■ F_y max. 300 N	max. 300 N	max. 150 N
■ F_z max. 300 N	max. 300 N	max. 150 N
■ M_x max. 7 Nm	max. 7 Nm	max. 4 Nm
■ M_y max. 7 Nm	max. 7 Nm	max. 4 Nm
■ M_z max. 15 Nm	max. 15 Nm	max. 8 Nm

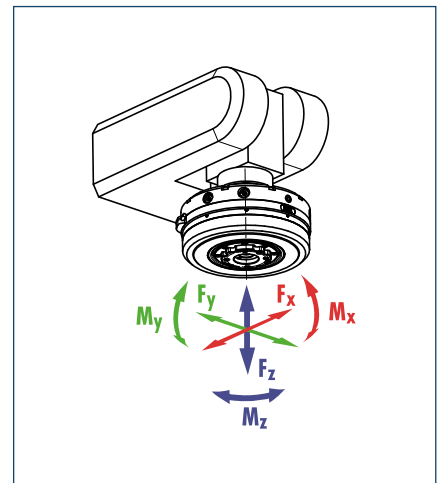

ⓘ In all six degrees of freedom overloads to the specified values are permitted without the sensor being damaged. Permissible external forces and moments in the event that the max. possible motion range of the tool-side flange is exceeded. System butts up to internal stops. If the specified external forces/moments are exceeded, the locking mechanism will be released in the opposite direction to the actuating pressure.

Technical data

Designation		FTCL-050-80	FTCL 50-40
	ID	0322351	0322350
Range of measurement, deflection			
Translatory X, Y, Z	[mm]	± 1.0	± 1.0
Rotational α , β , γ	[°]	± 1.0	± 1.0
Area of motion			
Translatory X, Y, Z	[mm]	± 1.4	± 1.4
Rotational α , β , γ	[°]	± 1.4	± 1.4
Overload			
F_x , F_y	[N]	-	-
F_z	[N]	-	-
M_x , M_y	[Nm]	-	-
M_z	[Nm]	-	-
Locking at 6 bar			
F_x , F_y	[N]	-	-
F_z	[N]	-	-
M_x , M_y	[Nm]	-	-
M_z	[Nm]	-	-
Robot-side interfaces		ISO 9409-1-A50	
Tool-side interfaces		ISO 9409-1-A50 as well as for gripper model PZN 64	
Mass moment of inertia I_{xx} , I_{yy}	[kg cm ²]	15.1	15.1
Mass moment of inertia I_{zz}	[kg cm ²]	24.3	24.3
Weight	[kg]	0.96	0.96
Min. ambient temperature	[°C]	5	5
Max. ambient temperature	[°C]	55	55
Power supply	[VDC]	10 - 26	10 - 26
Power consumption	[W]	1.8	1.8
IP rating		65	65

ⓘ Sensor FTC-050 with variable rigidity (80) and (40) springs, sensor FTC-050-XX with pneumatic, single-acting locking system (V), sensor FTC-L-050 light-weight version with variable rigidity (80) and (40) springs.

Main views FTCL-050

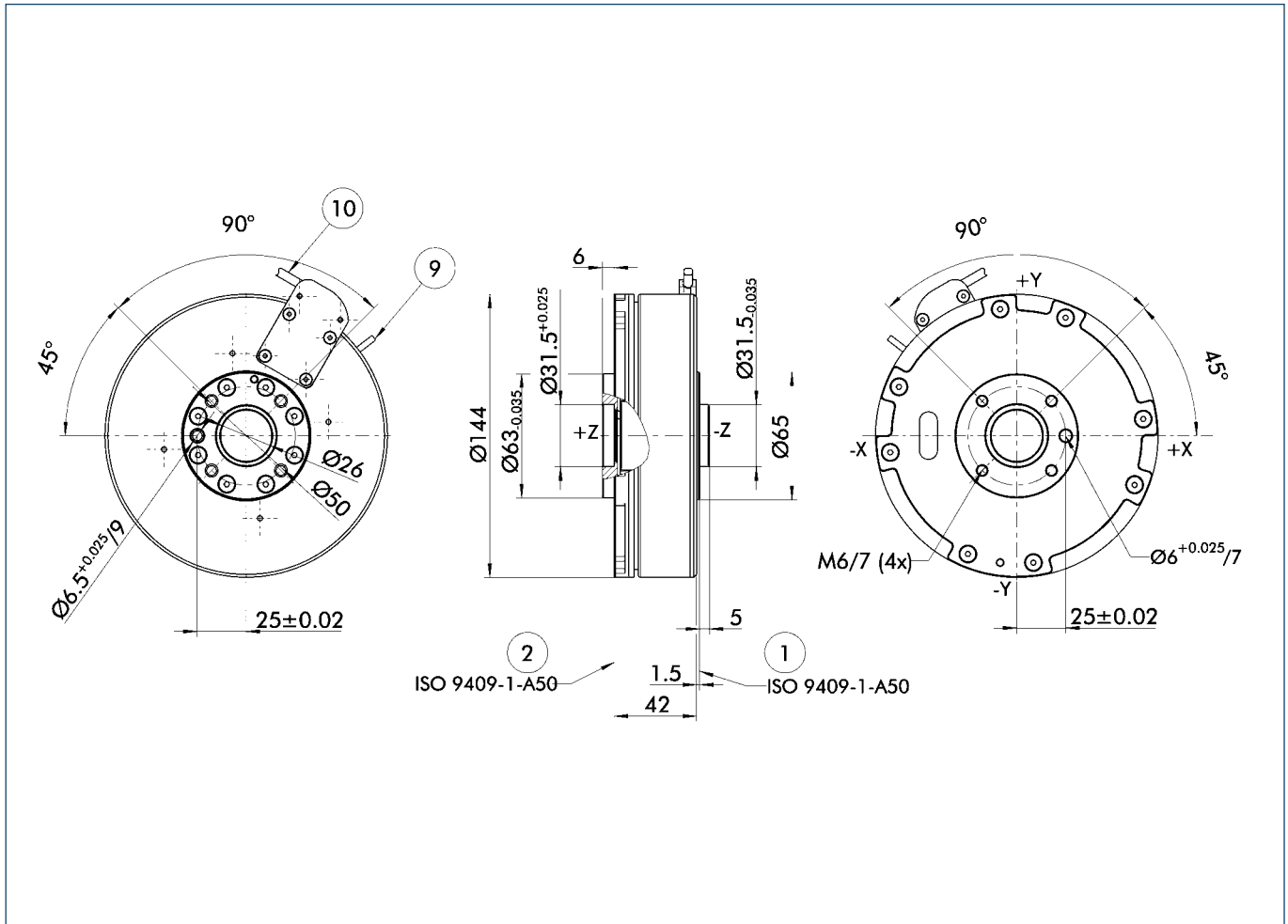

- ① Robot-side connection
- ② Tool-side connection

- ⑨ Status display
- ⑩ Connection cable

Adapter plate

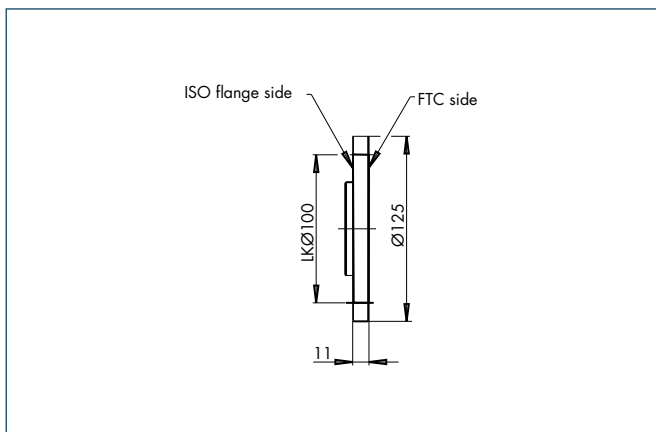

Adapter plate

Designation	ID
A-FTC-050-ISO A100	0322320

Adapter cable

Designation	Interface	Length	ID
FTC-K-RS 232-5	RS-232	5 m	0322340
FTC-K-CAN-5	CAN	5 m	0322341
FTC-K-RS 232-10	RS-232	10 m	0322342
FTC-K-CAN-10	CAN	10 m	0322343



Six series

Nano, Mini, Gamma, Delta,
Theta, Omega



Range of measurement, force

$\pm 36 \text{ N} \dots \pm 40000 \text{ N}$



Range of measurement, moment

$\pm 0.5 \text{ Nm} \dots \pm 6000 \text{ Nm}$

Application example

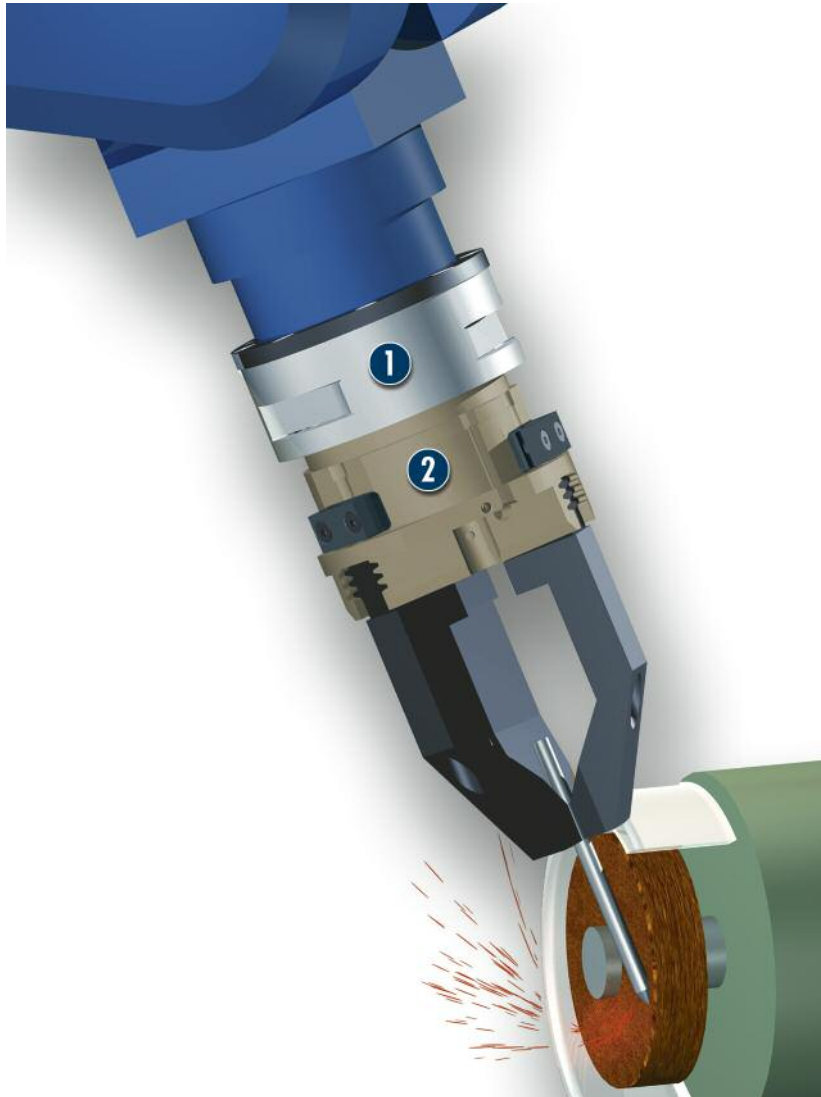

Robot-supported chamfering of round rods

- 1 FT-Delta 6-Axis Sensor
- 2 PZN-plus 64 3-Finger Centric Gripper

Force Sensor

6-axis sensor

Area of application

for precise measuring of forces and moments in all three spatial directions

Your advantages and benefits

Six sizes

with different ranges of measurement

High degree of resolution of measured values

and fast data transfer for virtually real-time force monitoring

Robust design

due to a higher overload range

Rotation and translation of the coordinates system

in all three directions

Robust design and easy to operate

for a long tool life and reduced set-up costs



General information on the sensor element

Working principle

Monolithic measuring element with three measurement harnesses at an angle of 120°. Each harness is fitted with two semiconductor strain gauge bridges which record the deformation in micrometers.

Overload protection

In all six axes, overloads to the values specified above are permitted without the sensor having to be recalibrated. Additional overload bolts protect the sensor from mechanical damage.

Material

Aluminum, stainless steel

Ambient temperature

0 °C to 70 °C, calibrated at 22 °C

Measuring accuracy

less than +/- 1% of the upper range value at 22 °C

Temperature compensation

Hardware side as standard

Splash protection

IP 65 on request

Warranty

12 months

FTD DAQ F/T system

The 6 axis force-torque sensor FTD is available in two different configurations, depending on the size of the sensor:

Sensor with integrated interface board

Delivered as standard:

- Sensor with interface board (from Gamma size)
- Sensor cable (10 m)
- Power supply box
- Connecting cable to the PC (2 m)

Sensor with external interface board

Delivered as standard:

- Sensor without interface board (sizes Nano and Mini)
- Sensor cable (1.8 m)
- Power supply box with integrated interface board
- Connecting cable to the PC (2 m)

Description of the individual components

6-axis force-torque sensor

Strain gauges (DMS) measure the strains applied in all six degrees of freedom (Fx, Fy, Fz, Tx, Ty and Tz). The DMS signals are amplified in the sensor. Because of the size, the interface board for the Nano and Mini series is not located in the sensor, but in the power supply box (IFPS).

Sensor cables

With the Nano and Mini sensors, the sensor cables are soldered into the sensor. A connector is located on the sensor housing of larger sensors to fix the sensor cable.

The highly-flexible sensor cable protects the sensor signals from electric fields and mechanical strains.

Interface board

The interface board converts the strain gauge signals into a signal which can be used by the DAQ card. To ensure optimum measurement results, the amplification factors are adjusted in line with the sensor used. The sensor and the interface board therefore form a single unit.

Power supply box

The power supply box contains the voltage transformer which converts the PC's 5 V power supply into a voltage which can be used by the sensor. In the Nano and Mini system the interface board is integrated into the box as well as the voltage transformer.

Connecting cable to the PC

The highly-flexible connecting cable carries the PC voltage to the power supply box and the sensor signals to the DAQ card.

Data acquisition card (DAQ)

The DAQ card converts the sensor's analog DMS signals into digital signals. DAQ cards are available for a wide variety of BUS systems (PCI, cPCI, PCMCIA, USB, ISA).

DAQ F/T system for Gamma and larger sensors

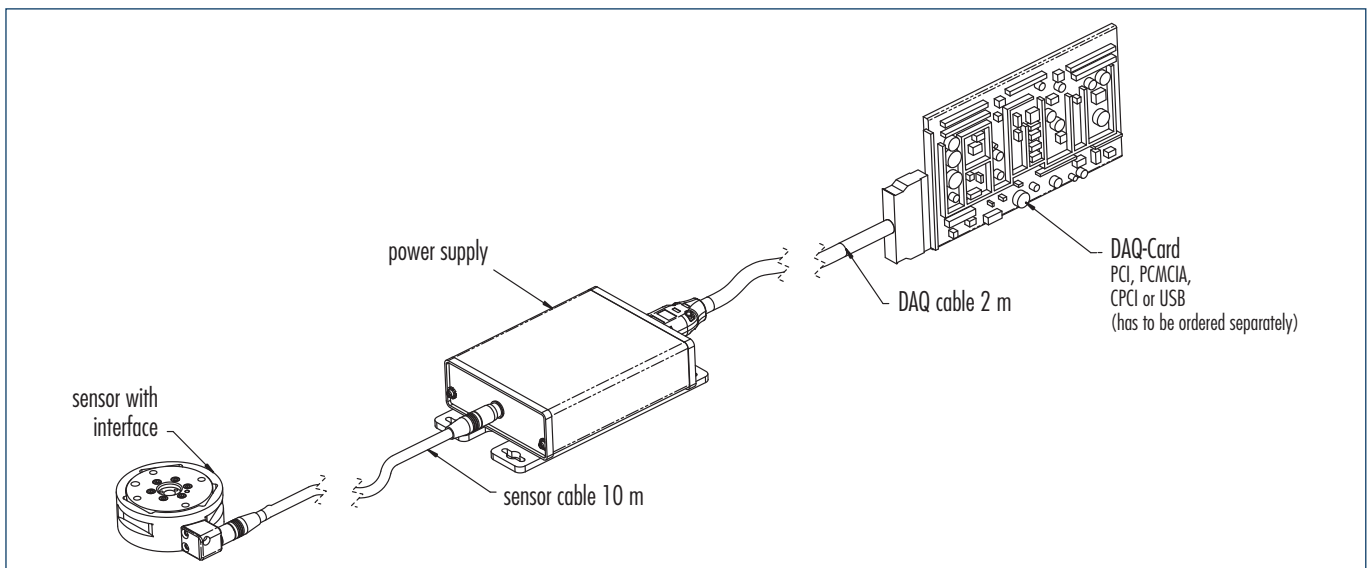

DAQ cards

The DAQ cards available for the sensor are shown in the list below. If you are already using DAQ hardware it could be used in differential or single-ended mode. We recommend differential-ended mode for an optimum, low-noise measurement signal.

Available DAQ cards

ID	Designation	Resolution	Bus	Max. transmission rate
0322005	FTD-DAQ-N1CPCI	16-bit	cPCI	14.2 K datasets/second
0322006	FTD-DAQ-N2CPCI	12-bit	cPCI	28.5 K datasets/second
0322003	FTD-DAQ-N1PCMCIA	16-bit	PCMCIA	28.5 K datasets/second
0322004	FTD-DAQ-N2PCMCIA	12-bit	PCMCIA	28.5 K datasets/second
0322011	FTD-DAQ-M1PCI	16-bit	PCI	250 K datasets/second

① The max. transmission rate is dependent upon the overall speed of the computer system.

The analog measurement values issued by the sensor are amplified strains from the strain gauges (DMS) and not forces and moments. The software provided converts the DMS signals into forces and moments. In order for the signals to be converted, all six DMS signals must be digitized by the DAQ card.

DAQ software

The DAQ F/T software provided contains Windows ActiveX components, a C library and an example program.

Software features

The automation server ATIDAQFT is a Windows ActiveX component which carries out the following functions:

- Importing the calibration file
- Configuring the sensor system
- Converting the sensor signals which are read in via the DAQ card into forces and moments
- Supporting tool transformation

The ATIDAQFT server has been developed for use in an ActiveX environment. The following programs are examples of those supported.

- LabVIEW™, Microsoft Visual Basic™, Visual Basic for Applications and Visual C++™
- For other operating systems a C library is available with the same range of functions.

Demo program

The Windows DAQ F/T demo program provides visual and numerical representations of forces and moments. A Windows operating system (Windows 95 or later) is required. The Visual Basic 6.0 source code is used as an aid for creating additional application programs. A LabVIEW application program is currently being developed.

DAQ F/T system for Mini and Nano sensors

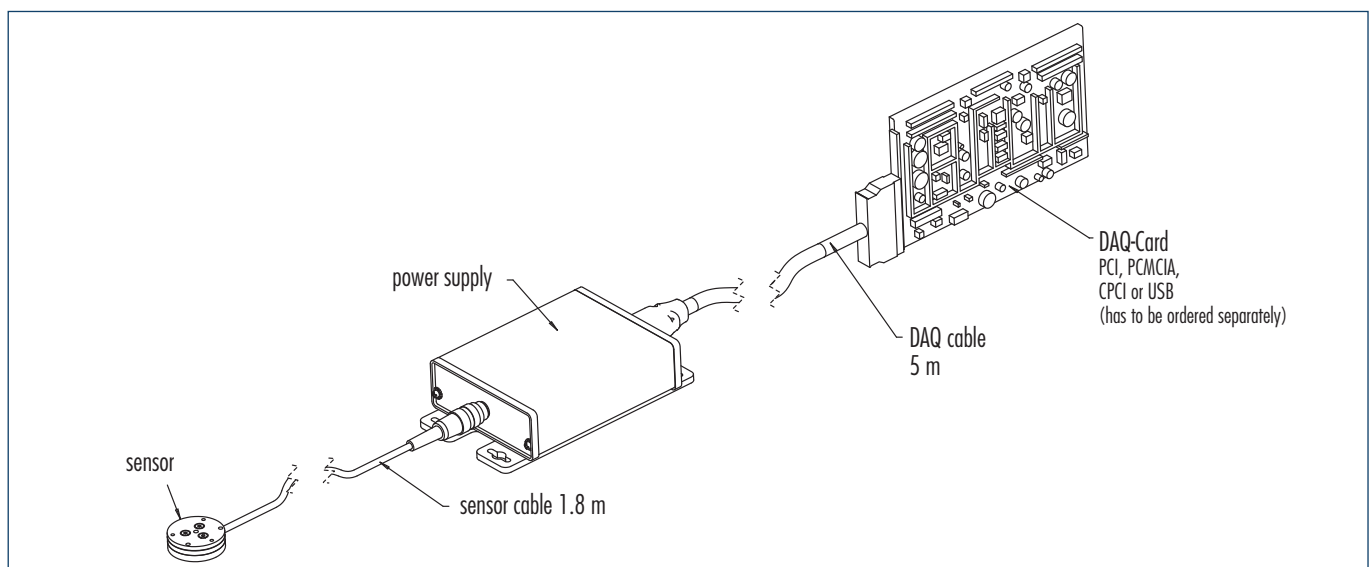

Stand alone controller, FTS version

The 6 axis force-torque sensor FTS is available in two different configurations, depending on the size of the sensor:

Sensor with integrated MULTIPLEX board

Delivered as standard:

- Sensor with MULTIPLEX board (from Gamma size)
- Sensor cable
- Stand alone controller
- Network cable

Sensor with external MULTIPLEX board

Delivered as standard:

- Sensor without MULTIPLEX board (sizes Nano and Mini)
- Sensor cable
- MULTIPLEX box
- MULTIPLEX cable
- Stand alone controller
- Network cable

Description of the individual components

6-axis force-torque sensor

Strain gauges (DMS) measure the strains applied in all six degrees of freedom (Fx, Fy, Fz, Tx, Ty and Tz). The DMS signals are prepared on the MULTIPLEX board. Because of the size, the MULTIPLEX board for the Nano and Mini series is not located in the sensor, but in the MULTIPLEX box.

Sensor cables

With the Nano and Mini sensors, the sensor cables are soldered into the sensor. A connector is mounted onto the sensor housing of larger sensors to fix the sensor cable. The highly-flexible sensor cable protects the sensor signals from electric fields and mechanical strains.

MULTIPLEX board

The MULTIPLEX board amplifies the strain gauge signals and issues them in multiplex form. To ensure optimum measurement results, the amplification factors are adjusted in line with the sensor used. The sensor and the MULTIPLEX board therefore form a single unit. With the Nano and Mini sensors, the MINI MULTIPLEX board is located in an extra box.

Stand alone controller

The stand alone controller is connected to the sensor or to the MULTIPLEX box. It converts the multiplex-form DMS signals into forces and moments. Functions such as tool transformation are implemented in the controller. Communication is carried out via an RS-232 interface. The force and moment measurement values are issued in the form of analog strains. Optically decoupled I/Os facilitate simple integration into the machine control system.

FTS system

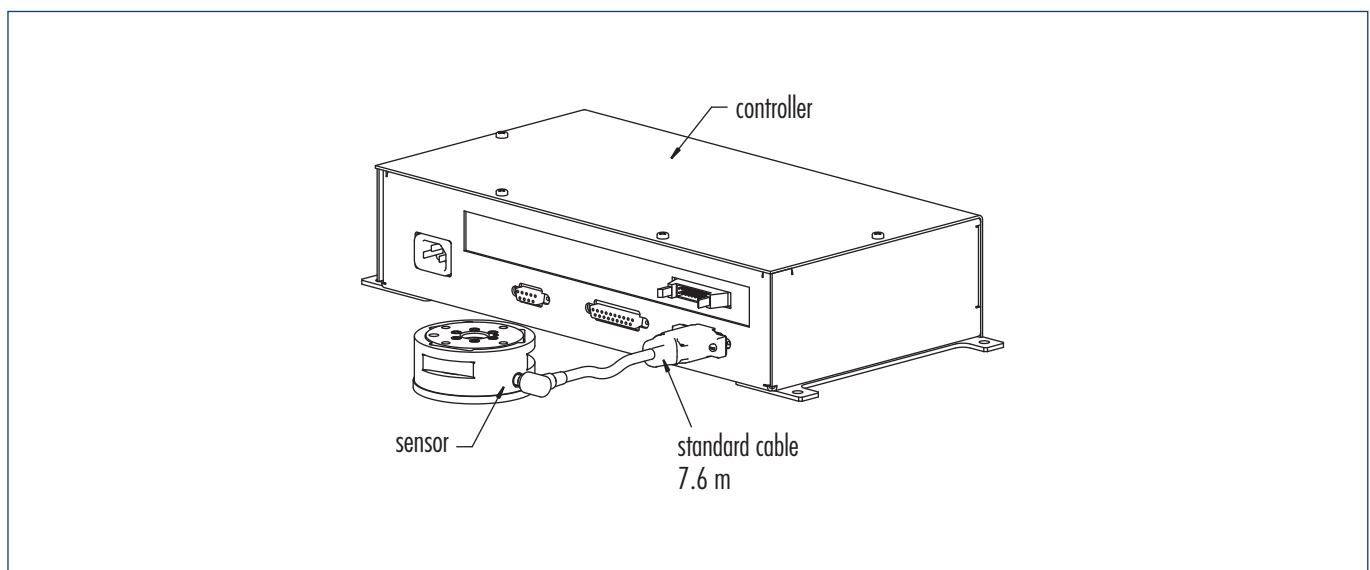

Sensor selection schematic

1. Calculating the expected forces and moments

The moment load is usually the determining factor when selecting a sensor. The tool weight and the application process generate the forces which can act upon the sensor in the form of moments. The moment is calculated from the force applied (static and dynamic) multiplied by the lever arm. The lever arm is calculated from the distance from the point of application of the force to the sensor's reference point. At the design stage, forces and moments which could act upon the sensor outside of normal operation also have to be taken into account.

2. Sensor pre-selection on the basis of the forces and moments

Please use the table below.

3. Determining the resolution

Check whether the sensor's resolution matches your requirements. It is possible that a sensor selected on the basis of the forces and moments does not meet the requirements with respect to resolution.

The basic principle is the larger the range of measurement, the lower the resolution.

Example

The maximum expected force acting on the sensor is 98 N (10 kg). This force acts on the sensor at a distance of 25 cm. The moment is therefore 24.5 Nm.

The FT-Delta-SI-330-30 is suitable for this application. (Range of measurement 330 N and 30 Nm). Overload safety is 230 Nm (Mxy).

Notes on robot applications

During a crash, extremely high forces and moments act on the sensor due to the robot's mass inertia and braking deceleration.

To protect the sensor in these situations, we recommend the use of an OPS or OPR collision and overload protection device.

Brief overview of FT

Designation		Nano	Nano	Nano	Mini	Mini	Gamma	Delta	Theta	Omega	Omega	Omega	Omega
		17	25	43	40	45				160	190	250	331
Max. F_{xy}	[± N]	50	250	36	80	580	130	660	2500	2500	7200	16000	40000
Max. M_{xy}	[± Nm]	0.5	6	0.5	4	20	10	60	400	400	1400	2000	6000
Weight	[kg]	0.01	0.07	0.04	0.05	0.09	0.25	0.91	4.99	2.72	6.35	30.0	43.0
Diameter	[mm]	17	25	43	40	45	75.4	94.5	155	156	190	254	254
Height	[mm]	14.5	21.6	11.5	12.3	15.7	33.3	33.3	61.1	55.9	55.9	95	107



How to order FTS sensors with stand-alone control

FTS-[sensor]-(cable) - □ - □ - □ - □

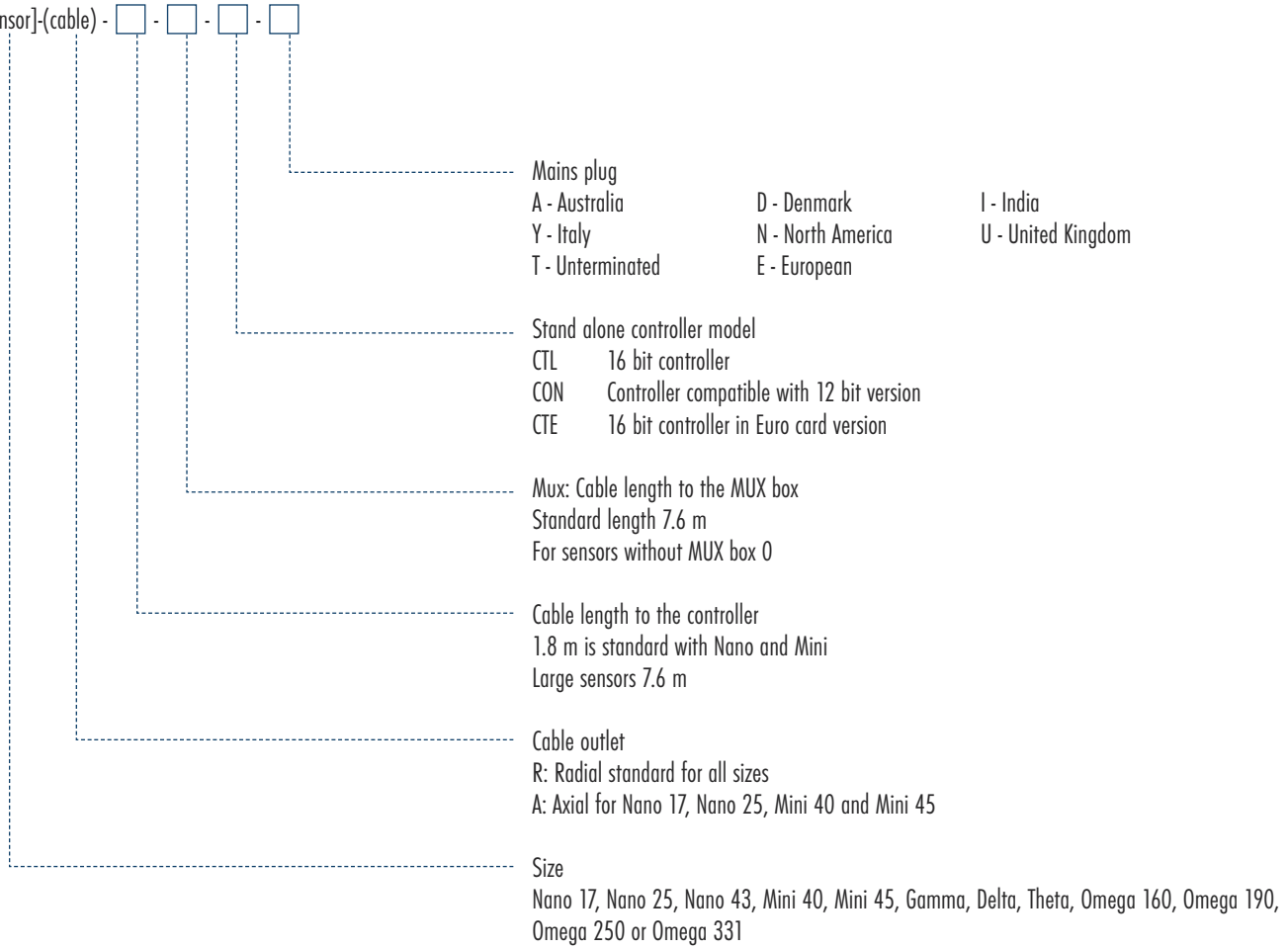

Mains plug
 A - Australia D - Denmark I - India
 Y - Italy N - North America U - United Kingdom
 T - Unterminated E - European

Stand alone controller model
 CTL 16 bit controller
 CON Controller compatible with 12 bit version
 CTE 16 bit controller in Euro card version

Mux: Cable length to the MUX box
 Standard length 7.6 m
 For sensors without MUX box 0

Cable length to the controller
 1.8 m is standard with Nano and Mini
 Large sensors 7.6 m

Cable outlet
 R: Radial standard for all sizes
 A: Axial for Nano 17, Nano 25, Mini 40 and Mini 45

Size
 Nano 17, Nano 25, Nano 43, Mini 40, Mini 45, Gamma, Delta, Theta, Omega 160, Omega 190,
 Omega 250 or Omega 331

How to order FTD sensors

FTD-[sensor]-(cable) - □ - □ - □

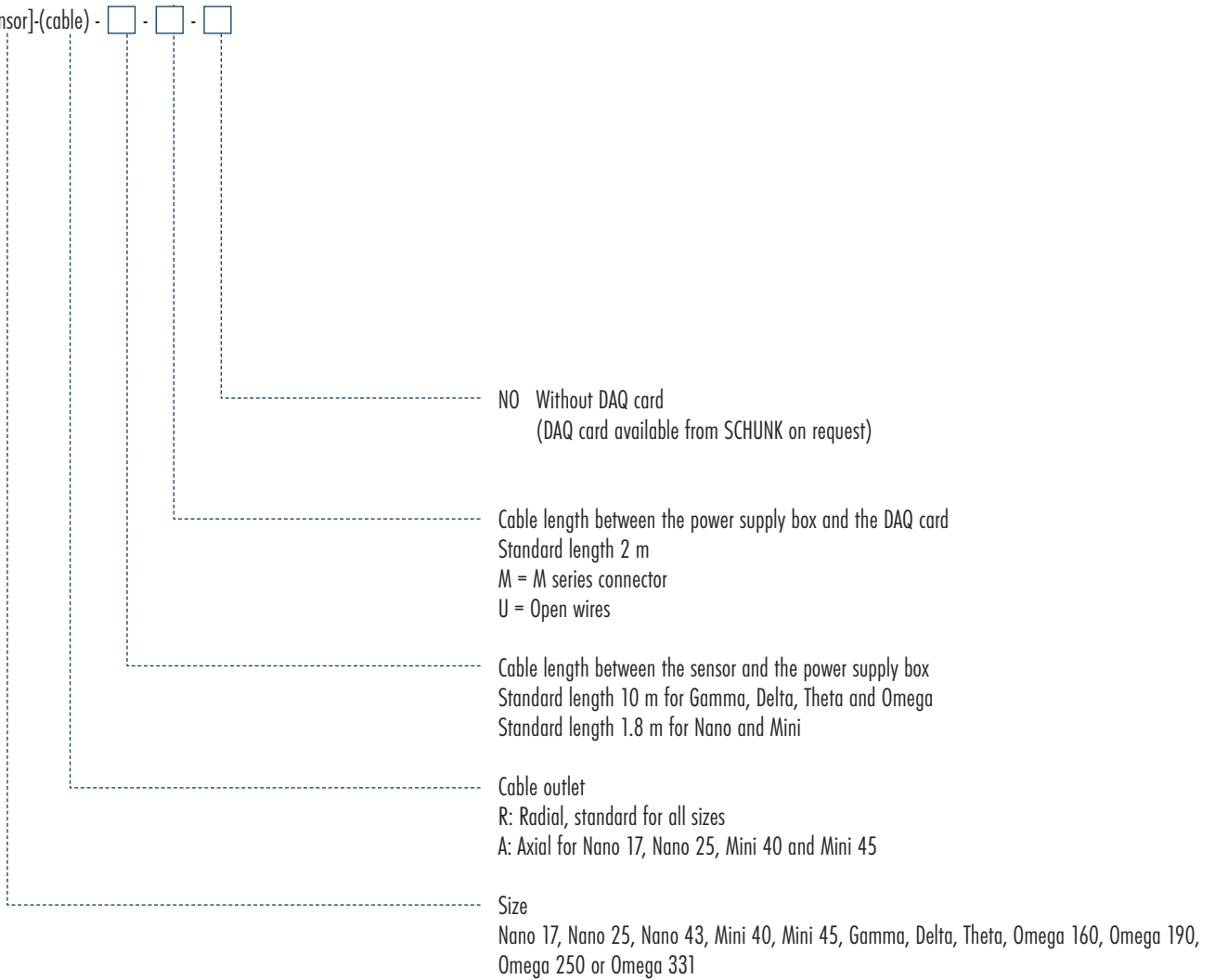



Product advantages

One of the smallest 6-axis sensors in the world

Suitable for measuring tasks in the small load range

Robust and compact

- Wire eroded measuring element made from high-strength, stainless steel
- Up to 23-fold overload safety with respect to the range of measurement

Measurement signal resistant to interference due to use of silicium strain gauges

Silicium strain gauges provide a signal which is 75 times stronger than conventional foil strain gauges. The silicium strain gauges reduce signal noise to practically nothing.

Typical areas of application

- Dental research
- Surgical robots
- The development of multi-limbed robot hands
- Studies into measuring finger strength

Technical data

Designation	FTS-Nano-17	FTD-Nano-17	FTS-Nano-17	FTD-Nano-17	FTS-Nano-17	FTD-Nano-17
Calibration	SI-12-0.12	SI-12-0.12	SI-25-0.25	SI-25-0.25	SI-50-0.5	SI-50-0.5
Resolution	Stand alone	DAQ	Stand alone	DAQ	Stand alone	DAQ
Mass	[g]	9.1	9.1	9.1	9.1	9.1
Range of measurement, F_x, F_y	[N]	± 12	± 12	± 25	± 25	± 50
Range of measurement, F_z	[N]	± 17	± 17	± 35	± 35	± 70
Range of measurement, M_x, M_y	[Nm]	± 0.12	± 0.12	± 0.25	± 0.25	± 0.50
Range of measurement, M_z	[Nm]	± 0.12	± 0.12	± 0.25	± 0.25	± 0.50
Resolution, F_x, F_y	[N]	± 1/160	± 1/1280	± 1/80	± 1/320	± 1/160
Resolution, F_z	[N]	± 1/160	± 1/1280	± 1/80	± 1/640	± 1/320
Resolution, M_x, M_y	[N]	± 1/32	± 1/256	± 1/16	± 1/128	± 1/64
Resolution, M_z	[Nm]	± 1/32	± 1/256	± 1/16	± 1/128	± 1/64
Overload, F_{xy}	[N]	± 350	± 350	± 350	± 350	± 350
Overload, F_z	[N]	± 800	± 800	± 800	± 800	± 800
Overload, T_{xy}	[Nm]	± 2.6	± 2.6	± 2.6	± 2.6	± 2.6
Overload, T_z	[Nm]	± 3.1	± 3.1	± 3.1	± 3.1	± 3.1
Rigidity, force XY axis (KF_x, KF_y)	[N/m]	9.3×10^6	9.3×10^6	9.3×10^6	9.3×10^6	9.3×10^6
Rigidity, Z axis (KF_z)	[N/m]	12×10^6	12×10^6	12×10^6	12×10^6	12×10^6
Rigidity, force XY axis (KM_x, KM_y)	[Nm/rad]	250	250	250	250	250
Rigidity, Z axis (KM_z)	[Nm/rad]	390	390	390	390	390
Resonance, frequency F_x, F_y, M_z	[KHz]	7.2	7.2	7.2	7.2	7.2
Resonance, frequency F_z, M_x, M_y	[KHz]	7.2	7.2	7.2	7.2	7.2

Main views

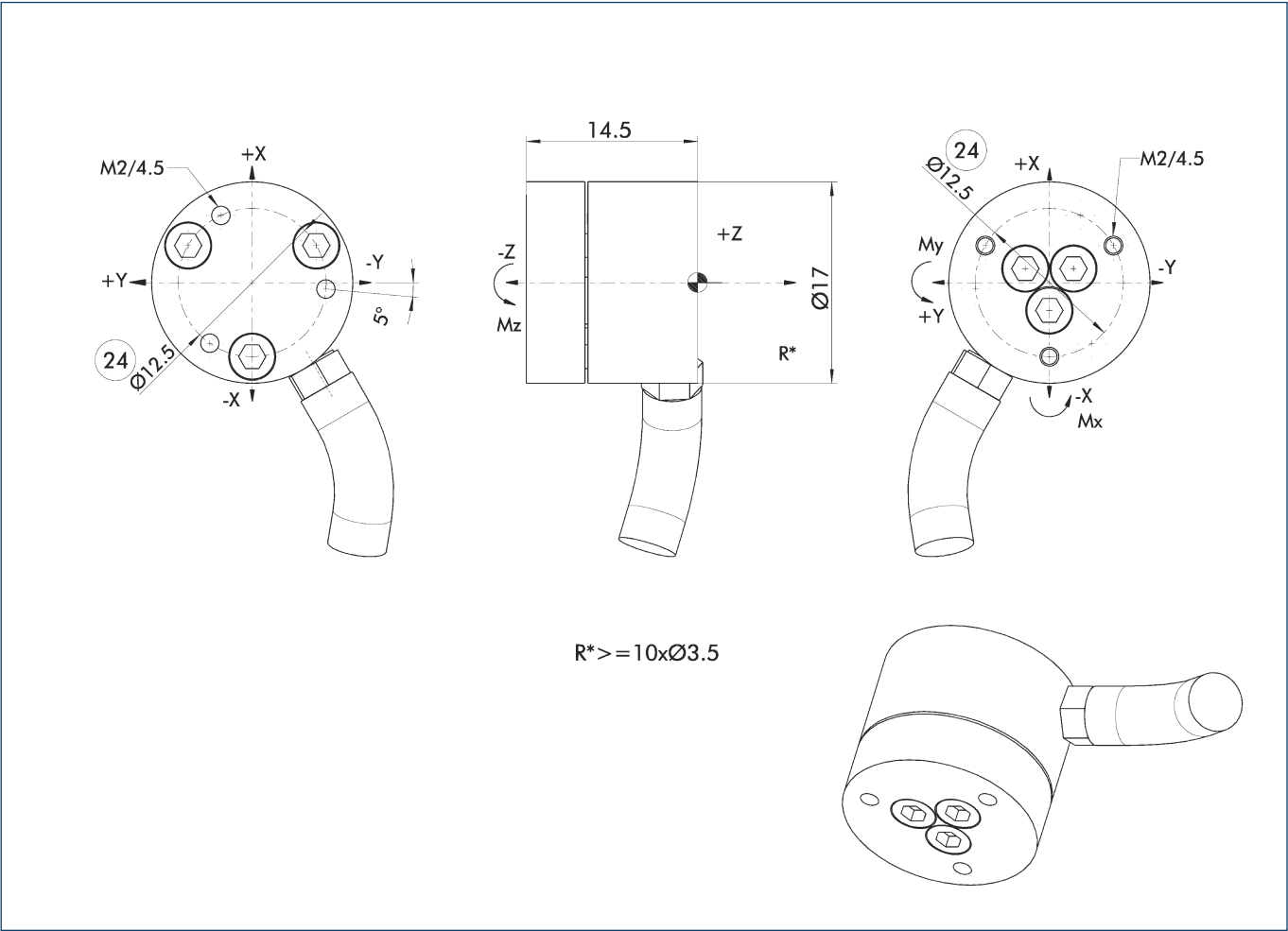

24 Bolt pitch circle





Product advantages

One of the smallest 6-axis sensors in the world

Suitable for measuring tasks in the small load range

Robust and compact

- Wire eroded measuring element made from high-strength, stainless steel
- Up to 23-fold overload safety with respect to the range of measurement

Measurement signal resistant to interference due to use of silicium strain gauges

Silicium strain gauges provide a signal which is 75 times stronger than conventional foil strain gauges. The silicium strain gauges reduce signal noise to practically nothing.

Typical areas of application

- Telerobotics
- Surgical robots
- The development of multi-limbed robot hands
- Studies into measuring finger strength

Technical data

Designation		FTS-Nano-25	FTD-Nano-25	FTS-Nano-25	FTD-Nano-25
Calibration		SI-125-3	SI-125-3	SI-250-6	SI-250-6
Resolution		Stand alone	DAQ	Stand alone	DAQ
Mass	[g]	63.4	63.4	63.4	63.4
Range of measurement, F_x, F_y	[N]	± 125	± 125	± 250	± 250
Range of measurement, F_z	[N]	± 500	± 500	± 1000	± 1000
Range of measurement, M_x, M_y	[Nm]	± 3	± 3	± 6	± 6
Range of measurement, M_z	[Nm]	± 3	± 3	± 6	± 6
Resolution, F_x, F_y	[N]	± 1/24	± 1/192	± 1/12	± 1/96
Resolution, F_z	[N]	± 1/8	± 1/64	± 1/4	± 1/32
Resolution, M_x, M_y	[N]	± 1/660	± 1/5280	± 1/330	± 1/2640
Resolution, M_z	[Nm]	± 1/1320	± 1/10560	± 1/660	± 1/5280
Overload, F_{xy}	[N]	± 2325	± 2325	± 2325	± 2325
Overload, F_z	[N]	± 6250	± 6250	± 6250	± 6250
Overload, T_{xy}	[Nm]	± 35	± 35	± 35	± 35
Overload, T_z	[Nm]	± 62	± 62	± 62	± 62
Rigidity, force XY axis (KF_x, KF_y)	[N/m]	53×10^6	53×10^6	53×10^6	53×10^6
Rigidity, Z axis (KF_z)	[N/m]	110×10^6	110×10^6	110×10^6	110×10^6
Rigidity, force XY axis (KM_x, KM_y)	[Nm/rad]	6440	6440	6440	6440
Rigidity, Z axis (KM_z)	[Nm/rad]	9260	9260	9260	9260
Resonance, frequency F_x, F_y, M_z	[KHz]	3.6	3.6	3.6	3.6
Resonance, frequency F_z, M_x, M_y	[KHz]	3.8	3.8	3.8	3.8

Main views

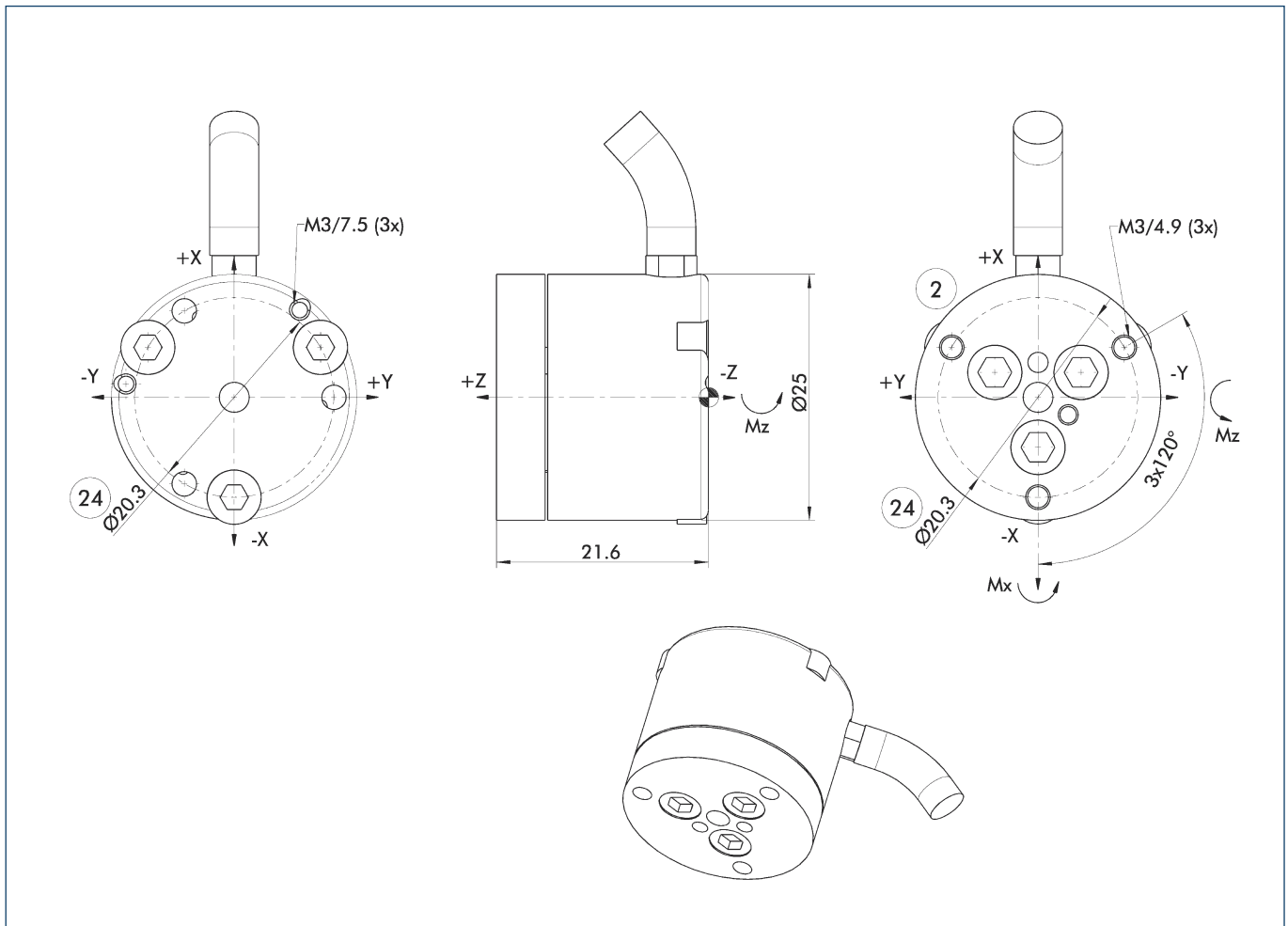

- ② Tool-side connection
- ②④ Bolt pitch circle



Product advantages

One of the smallest 6-axis sensors in the world

Suitable for measuring tasks in the small load range

Robust and compact

- Wire eroded measuring element made from high-strength, stainless steel
- Up to 23-fold overload safety with respect to the range of measurement

Measurement signal resistant to interference due to use of silicium strain gauges

Silicium strain gauges provide a signal which is 75 times stronger than conventional foil strain gauges. The silicium strain gauges reduce signal noise to practically nothing.

Typical areas of application

- Telerobotics
- Surgical robots
- The development of multi-limbed robot hands
- Studies into measuring finger strength

Technical data

Designation		FTS-Nano-43	FTD-Nano-43	FTS-Nano-43	FTD-Nano-43
Calibration		SI-18-0.25	SI-18-0.25	SI-36-0.5	SI-36-0.5
	ID	0322042	0322520	0322043	0322521
Resolution		Stand alone	DAQ	Stand alone	DAQ
Mass	[g]	39	39	39	39
Range of measurement, F_x, F_y	[N]	± 18	± 18	± 36	± 36
Range of measurement, F_z	[N]	± 18	± 18	± 36	± 36
Range of measurement, M_x, M_y	[Nm]	± 0.25	± 0.25	± 0.5	± 0.5
Range of measurement, M_z	[Nm]	± 0.25	± 0.25	± 0.5	± 0.5
Resolution, F_x, F_y	[N]	± 1/128	± 1/1024	± 1/64	± 1/512
Resolution, F_z	[N]	± 1/128	± 1/1024	± 1/64	± 1/512
Resolution, M_x, M_y	[N]	± 1/10000	± 1/80000	± 1/5000	± 1/40000
Resolution, M_z	[Nm]	± 1/10000	± 1/80000	± 1/5000	± 1/40000
Overload, F_{xy}	[N]	± 300	± 300	± 300	± 300
Overload, F_z	[N]	± 400	± 400	± 400	± 400
Overload, T_{xy}	[Nm]	± 3.4	± 3.4	± 3.4	± 3.4
Overload, T_z	[Nm]	± 5.4	± 5.4	± 5.4	± 5.4
Rigidity, force XY axis (KF_x, KF_y)	[N/m]	5.2×10^6	5.2×10^6	5.2×10^6	5.2×10^6
Rigidity, Z axis (KF_z)	[N/m]	5.2×10^6	5.2×10^6	5.2×10^6	5.2×10^6
Rigidity, force XY axis (KM_x, KM_y)	[Nm/rad]	770	770	770	770
Rigidity, Z axis (KM_z)	[Nm/rad]	1100	1100	1100	1100

Main views

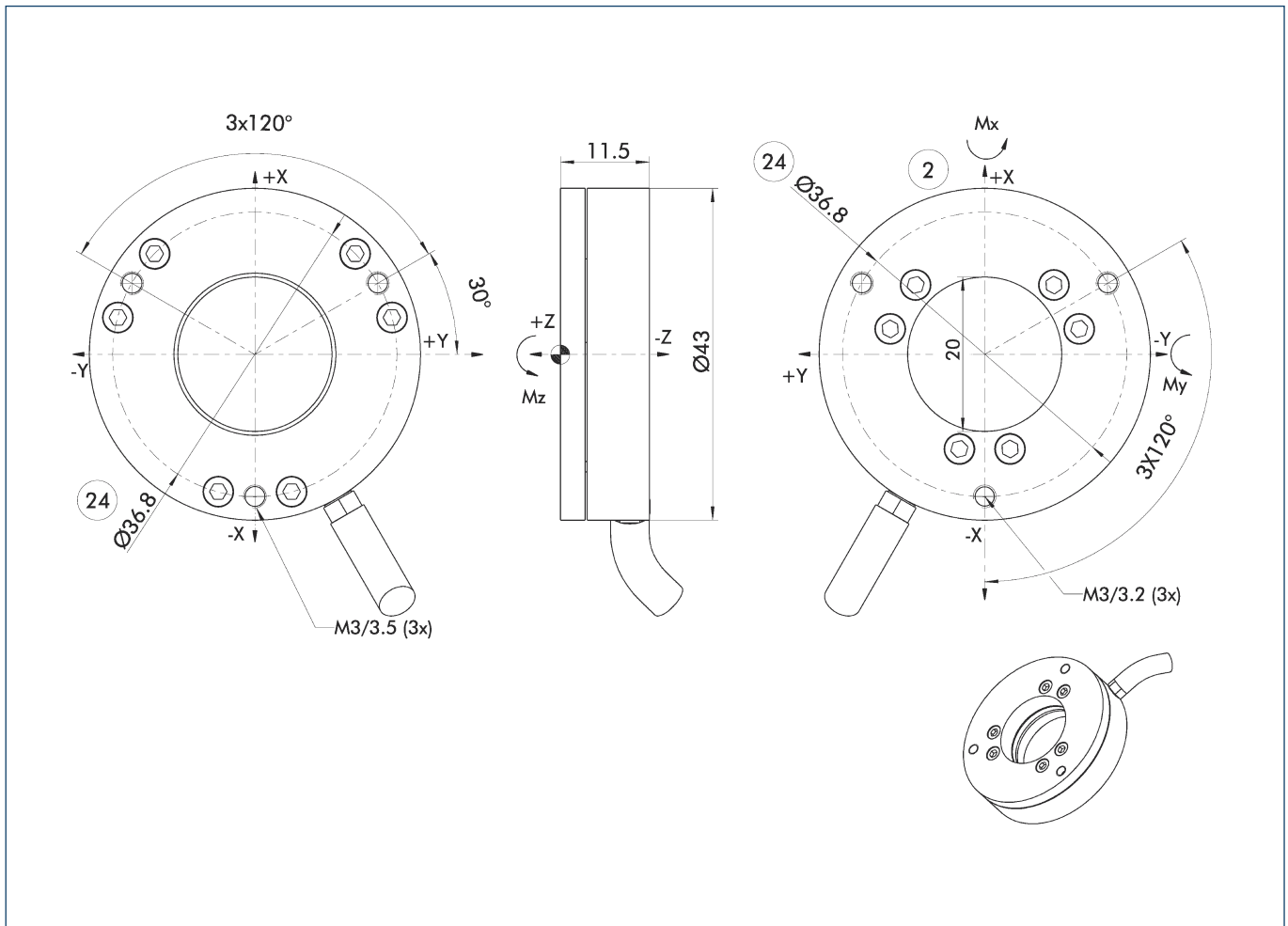

- ② Tool-side connection
- ②④ Bolt pitch circle



Product advantages

One of the smallest 6-axis sensors in the world

The Mini 40 is a compact, flat sensor.

Robust and compact

- Wire eroded measuring element made from high-strength, stainless steel
- Up to 18-fold overload safety with respect to the range of measurement

Measurement signal resistant to interference due to use of silicium strain gauges

Silicium strain gauges provide a signal which is 75 times stronger than conventional foil strain gauges. The silicium strain gauges reduce signal noise to practically nothing.

Typical areas of application

- Telerobotics
- Surgical robots
- The development of multi-limbed robot hands
- Studies into measuring finger strength

Technical data

Designation		FTS-Mini-40	FTD-Mini-40	FTS-Mini-40	FTD-Mini-40	FTS-Mini-40	FTD-Mini-40
Calibration		SI-20-1	SI-20-1	SI-40-2	SI-40-2	SI-80-4	SI-80-4
Resolution		Stand alone	DAQ	Stand alone	DAQ	Stand alone	DAQ
Mass	[g]	50	50	50	50	50	50
Range of measurement, F_x, F_y	[N]	± 20	± 20	± 40	± 40	± 80	± 80
Range of measurement, F_z	[N]	± 60	± 60	± 120	± 120	± 240	± 240
Range of measurement, M_x, M_y	[Nm]	± 1	± 1	± 2	± 2	± 4	± 4
Range of measurement, M_z	[Nm]	± 1	± 1	± 2	± 2	± 4	± 4
Resolution, F_x, F_y	[N]	± 1/100	± 1/800	± 1/50	± 1/400	± 2/25	± 1/200
Resolution, F_z	[N]	± 1/50	± 1/400	± 1/25	± 1/200	± 4/25	± 1/100
Resolution, M_x, M_y	[N]	± 1/4000	± 1/32000	± 1/2000	± 1/16000	± 1/1000	± 1/8000
Resolution, M_z	[Nm]	± 1/4000	± 1/32000	± 1/2000	± 1/16000	± 1/1000	± 1/8000
Overload, F_{xy}	[N]	± 870	± 870	± 870	± 870	± 870	± 870
Overload, F_z	[N]	± 2700	± 2700	± 2700	± 2700	± 2700	± 2700
Overload, T_{xy}	[Nm]	± 21	± 21	± 21	± 21	± 21	± 21
Overload, T_z	[Nm]	± 21	± 21	± 21	± 21	± 21	± 21
Rigidity, force XY axis (KF_x, KF_y)	[N/m]	11 x 10 ⁶	11 x 10 ⁶	11 x 10 ⁶	11 x 10 ⁶	11 x 10 ⁶	11 x 10 ⁶
Rigidity, Z axis (KF_z)	[N/m]	23 x 10 ⁶	23 x 10 ⁶	23 x 10 ⁶	23 x 10 ⁶	23 x 10 ⁶	23 x 10 ⁶
Rigidity, force XY axis (KM_x, KM_y)	[Nm/rad]	3300	3300	3300	3300	3300	3300
Rigidity, Z axis (KM_z)	[Nm/rad]	4300	4300	4300	4300	4300	4300
Resonance, frequency F_x, F_y, M_z	[KHz]	3.2	3.2	3.2	3.2	3.2	3.2
Resonance, frequency F_z, M_x, M_y	[KHz]	4.9	4.9	4.9	4.9	4.9	4.9

Main views

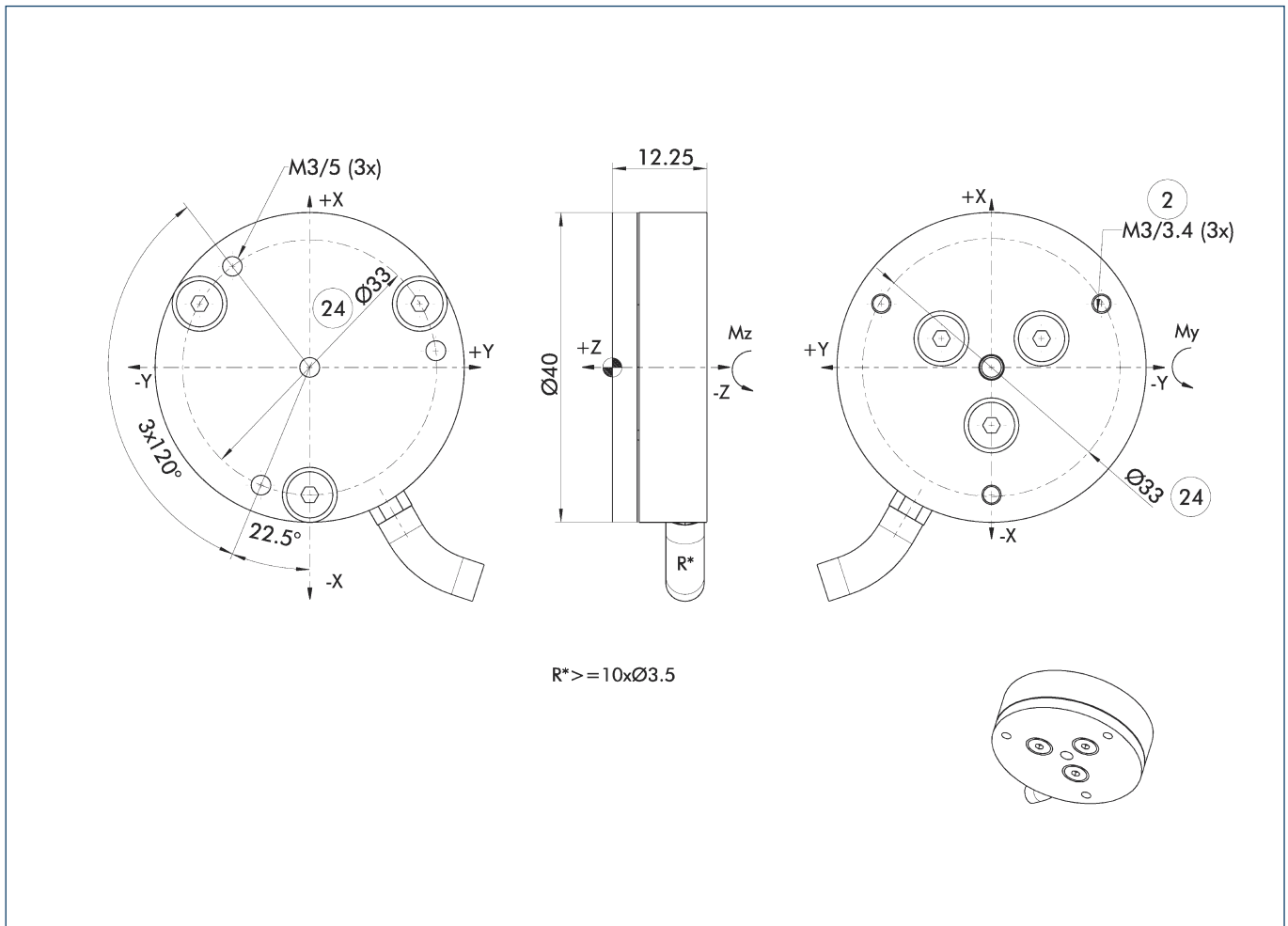

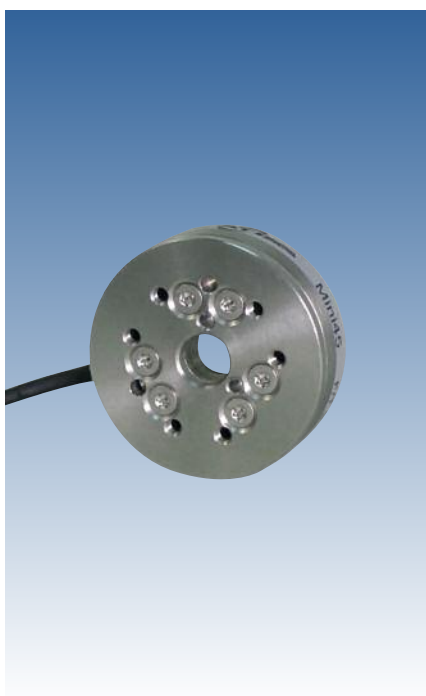

Product advantages

One of the smallest 6-axis sensors in the world

The Mini 45 is a compact, flat sensor.

Robust and compact

- Wire eroded measuring element made from high-strength, stainless steel
- Up to 23-fold overload safety with respect to the range of measurement

Measurement signal resistant to interference due to use of silicium strain gauges

Silicium strain gauges provide a signal which is 75 times stronger than conventional foil strain gauges. The silicium strain gauges reduce signal noise to practically nothing.

Typical areas of application

- Telerobotics
- Surgical robots
- The development of multi-limbed robot hands
- Studies into measuring finger strength

Technical data

Designation		FTS-Mini-45	FTD-Mini-45	FTS-Mini-45	FTD-Mini-45	FTS-Mini-45	FTD-Mini-45
Calibration		SI-145-5	SI-145-5	SI-290-10	SI-290-10	SI-580-20	SI-580-20
	ID	0322060	0322540	0322061	0322541	0322062	0322542
Resolution		Stand alone	DAQ	Stand alone	DAQ	Stand alone	DAQ
Mass	[g]	90	90	90	90	90	90
Range of measurement, F_x, F_y	[N]	± 145	± 145	± 290	± 290	± 580	± 580
Range of measurement, F_z	[N]	± 290	± 290	± 580	± 580	± 1160	± 1160
Range of measurement, M_x, M_y	[Nm]	± 5	± 5	± 10	± 10	± 20	± 20
Range of measurement, M_z	[Nm]	± 5	± 5	± 10	± 10	± 20	± 20
Resolution, F_x, F_y	[N]	± 1/8	± 1/128	± 1/4	± 1/64	± 1/2	± 1/32
Resolution, F_z	[N]	± 1/8	± 1/64	± 1/4	± 1/32	± 1/2	± 1/16
Resolution, M_x, M_y	[N]	± 1/376	± 1/188	± 1/188	± 1/3008	± 1/94	± 1/1504
Resolution, M_z	[Nm]	± 1/352	± 1/188	± 1/376	± 1/3008	± 1/188	± 1/1504
Overload, F_{xy}	[N]	± 4900	± 4900	± 4900	± 4900	± 4900	± 4900
Overload, F_z	[N]	± 10100	± 10100	± 10100	± 10100	± 10100	± 10100
Overload, T_{xy}	[Nm]	± 100	± 100	± 100	± 100	± 100	± 100
Overload, T_z	[Nm]	± 135	± 135	± 135	± 135	± 135	± 135
Rigidity, force XY axis (KF_x, KF_y)	[N/m]	74.6×10^6	74.6×10^6	74.6×10^6	74.6×10^6	74.6×10^6	74.6×10^6
Rigidity, Z axis (KF_z)	[N/m]	98.4×10^6	98.4×10^6	98.4×10^6	98.4×10^6	98.4×10^6	98.4×10^6
Rigidity, force XY axis (KM_x, KM_y)	[Nm/rad]	16.8×10^3	16.8×10^3	16.8×10^3	16.8×10^3	16.8×10^3	16.8×10^3
Rigidity, Z axis (KM_z)	[Nm/rad]	34.8×10^3	34.8×10^3	34.8×10^3	34.8×10^3	34.8×10^3	34.8×10^3

Main views

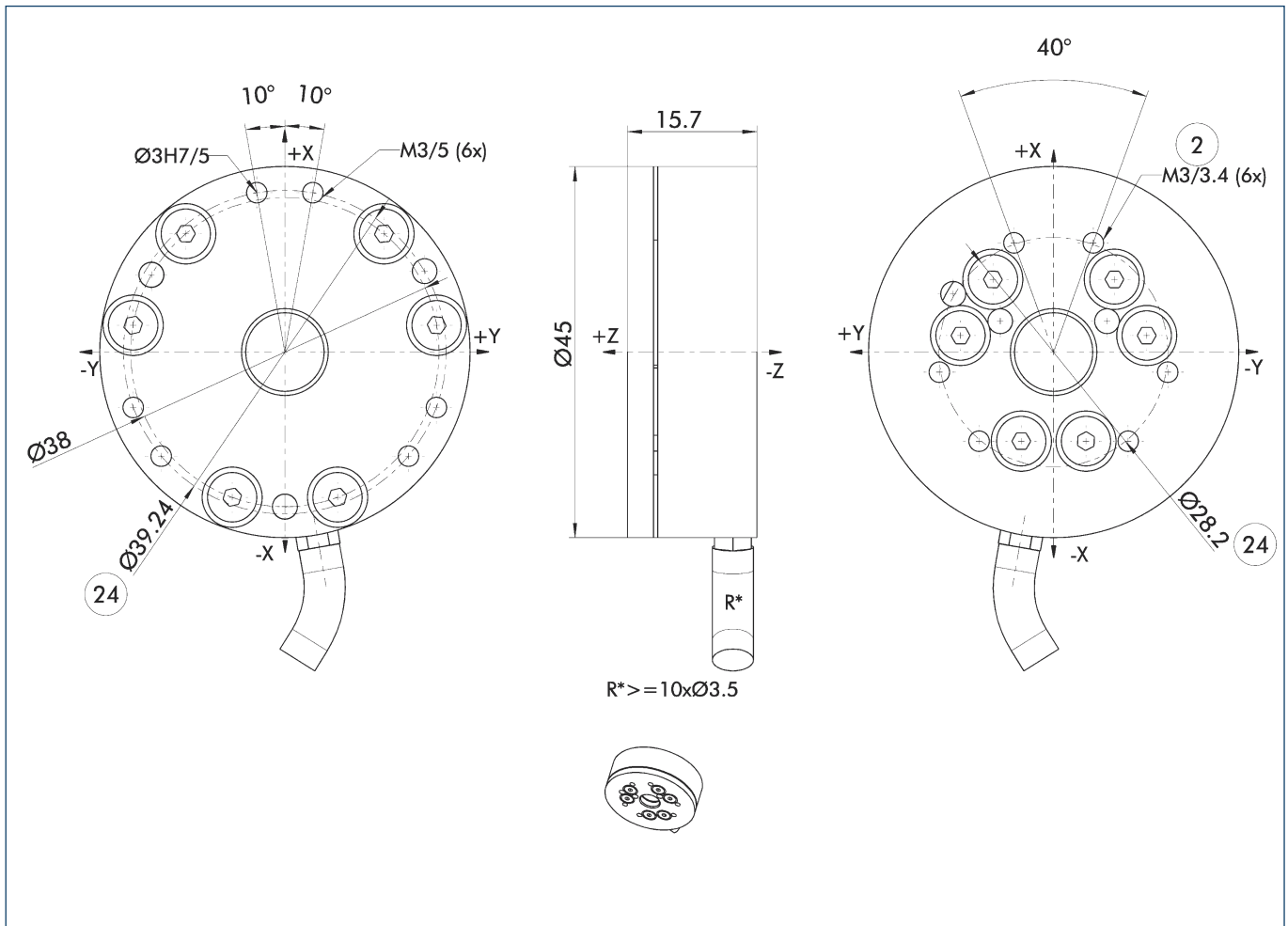

Product advantages

Robust and compact

- Wire eroded measuring element made from high-strength, stainless steel
- Up to 27-fold overload safety with respect to the range of measurement

Measurement signal resistant to interference due to use of silicium strain gauges

Silicium strain gauges provide a signal which is 75 times stronger than conventional foil strain gauges. The silicium strain gauges reduce signal noise to practically nothing.

Typical areas of application

- Real-time force monitoring
- Haptics investigations
- Robot set-up
- Tests in automotive engineering



Technical data

Designation	FTS-Gamma	FTD-Gamma	FTS-Gamma	FTD-Gamma	FTS-Gamma	FTD-Gamma
Calibration	SI-32-2.5	SI-32-2.5	SI-65-5	SI-65-5	SI-130-10	SI-130-10
Resolution	Stand alone	DAQ	Stand alone	DAQ	Stand alone	DAQ
Mass [g]	225	225	225	225	225	225
Range of measurement, F_x, F_y [N]	± 32	± 32	± 65	± 65	± 130	± 130
Range of measurement, F_z [N]	± 100	± 100	± 200	± 200	± 400	± 400
Range of measurement, M_x, M_y [Nm]	± 2.5	± 2.5	± 5	± 5	± 10	± 10
Range of measurement, M_z [Nm]	± 2.5	± 2.5	± 5	± 5	± 10	± 10
Resolution, F_x, F_y [N]	± 1/80	± 1/640	± 1/40	± 1/320	± 1/20	± 1/160
Resolution, F_z [N]	± 1/40	± 1/320	± 1/20	± 1/160	± 1/10	± 1/80
Resolution, M_x, M_y [N]	± 1/1000	± 1/8000	± 1/667	± 3/16000	± 1/400	± 1/3200
Resolution, M_z [Nm]	± 1/1000	± 1/8000	± 1/667	± 3/16000	± 1/400	± 1/3200
Overload, F_{xy} [N]	± 1210	± 1210	± 1210	± 1210	± 1210	± 1210
Overload, F_z [N]	± 4050	± 4050	± 4050	± 4050	± 4050	± 4050
Overload, T_{xy} [Nm]	± 78	± 78	± 78	± 78	± 78	± 78
Overload, T_z [Nm]	± 82	± 82	± 82	± 82	± 82	± 82
Rigidity, force XY axis (KF_x, KF_y) [N/m]	9.1×10^6	9.1×10^6	9.1×10^6	9.1×10^6	9.1×10^6	9.1×10^6
Rigidity, Z axis (KF_z) [N/m]	18×10^6	18×10^6	18×10^6	18×10^6	18×10^6	18×10^6
Rigidity, force XY axis (KM_x, KM_y) [Nm/rad]	11×10^3	11×10^3	11×10^3	11×10^3	11×10^3	11×10^3
Rigidity, Z axis (KM_z) [Nm/rad]	16×10^3	16×10^3	16×10^3	16×10^3	16×10^3	16×10^3
Resonance, frequency F_x, F_y, M_z [KHz]	1.4	1.4	1.4	1.4	1.4	1.4
Resonance, frequency F_z, M_x, M_y [KHz]	2	2	2	2	2	2

Main views

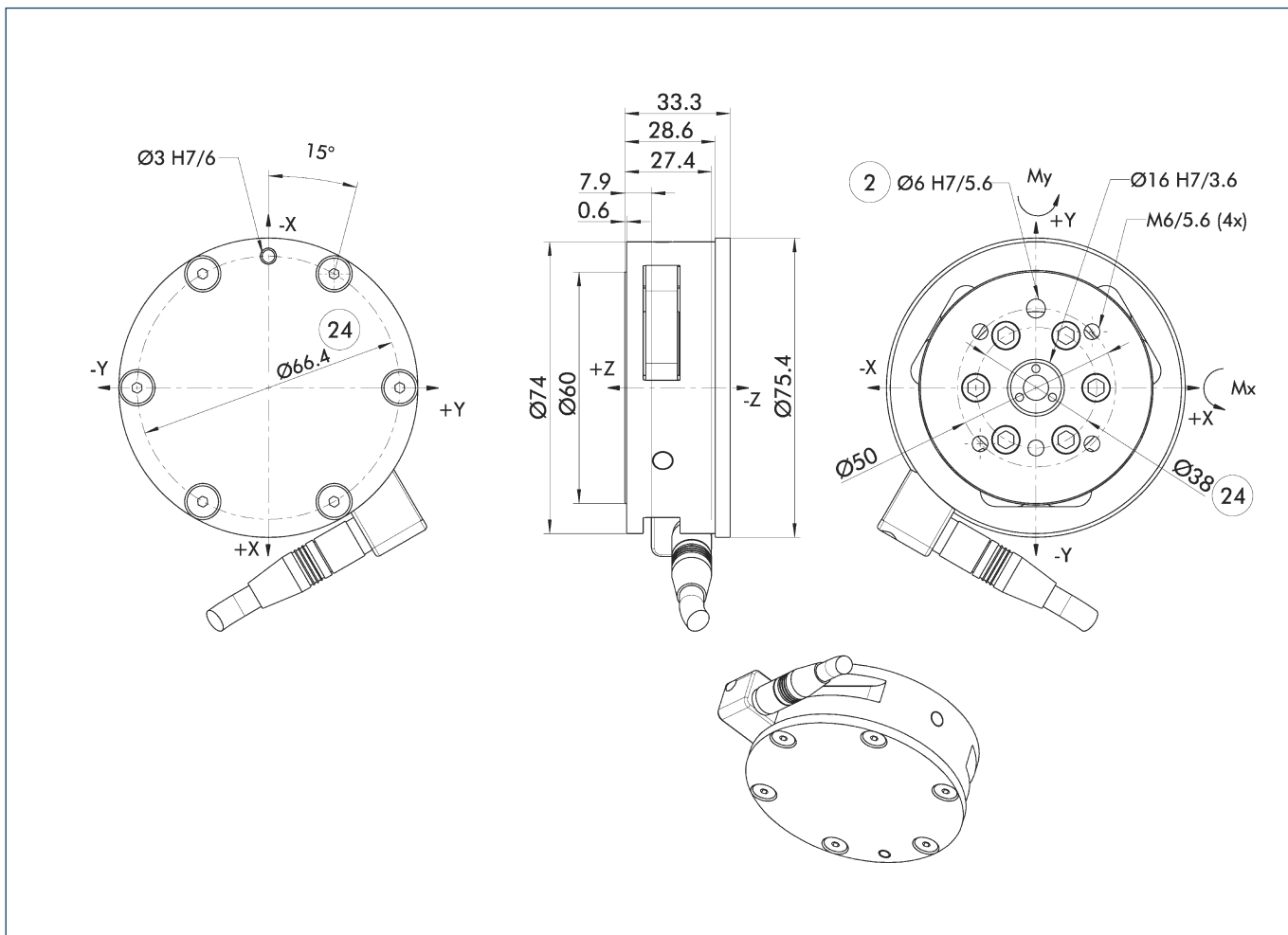

- ② Tool-side connection
- ② Bolt pitch circle



Product advantages

- Wire eroded measuring element made from high-strength, stainless steel
- Special overload bolts make the Delta an extremely robust transducer
- Up to 148-fold overload safety with respect to the range of measurement

Measurement signal resistant to interference due to use of silicium strain gauges

Silicium strain gauges provide a signal which is 75 times stronger than conventional foil strain gauges. The silicium strain gauges reduce signal noise to practically nothing.

Sensor also available in the following protection classes

- IP 60 dust-proof version
 - IP 65 splash-proof version, suitable for use in damp environments
 - IP 68 immersion-proof version down to 10 m
- For further information or drawings please feel free to contact us. We will be happy to help.

Typical areas of application

- Real-time force monitoring
- Robot set-up
- Haptics investigations
- Rehabilitation research

Technical data

Designation	FTS-Delta	FTD-Delta	FTS-Delta	FTD-Delta	FTS-Delta	FTD-Delta
Calibration	SI-165-15	SI-165-15	SI-330-30	SI-330-30	SI-660-60	SI-660-60
Resolution	Stand alone	DAQ	Stand alone	DAQ	Stand alone	DAQ
Mass [g]	913	913	913	913	913	913
Range of measurement, F_x, F_y [N]	± 165	± 165	± 330	± 330	± 660	± 660
Range of measurement, F_z [N]	± 495	± 495	± 990	± 990	± 1980	± 1980
Range of measurement, M_x, M_y [Nm]	± 15	± 15	± 30	± 30	± 60	± 60
Range of measurement, M_z [Nm]	± 15	± 15	± 30	± 30	± 60	± 60
Resolution, F_x, F_y [N]	± 1/16	± 1/128	± 1/8	± 1/64	± 1/4	± 1/32
Resolution, F_z [N]	± 1/8	± 1/64	± 1/4	± 1/32	± 1/2	± 1/16
Resolution, M_x, M_y [N]	± 1/264	± 1/2112	± 3/400	± 3/3200	± 3/200	± 1/1600
Resolution, M_z [Nm]	± 1/264	± 1/2112	± 3/400	± 3/3200	± 3/200	± 1/1600
Overload, F_{xy} [N]	± 3500	± 3500	± 3500	± 3500	± 3500	± 3500
Overload, F_z [N]	± 11900	± 11900	± 11900	± 11900	± 11900	± 11900
Overload, T_{xy} [Nm]	± 230	± 230	± 230	± 230	± 230	± 230
Overload, T_z [Nm]	± 420	± 420	± 420	± 420	± 420	± 420
Rigidity, force XY axis (KF_x, KF_y) [N/m]	37×10^6	37×10^6	37×10^6	37×10^6	37×10^6	37×10^6
Rigidity, Z axis (KF_z) [N/m]	61×10^6	61×10^6	61×10^6	61×10^6	61×10^6	61×10^6
Rigidity, force XY axis (KM_x, KM_y) [Nm/rad]	52×10^3	52×10^3	52×10^3	52×10^3	52×10^3	52×10^3
Rigidity, Z axis (KM_z) [Nm/rad]	94×10^3	94×10^3	94×10^3	94×10^3	94×10^3	94×10^3
Resonance, frequency F_x, F_y, M_z [KHz]	1.5	1.5	1.5	1.5	1.5	1.5
Resonance, frequency F_z, M_x, M_y [KHz]	1.7	1.7	1.7	1.7	1.7	1.7

Main views

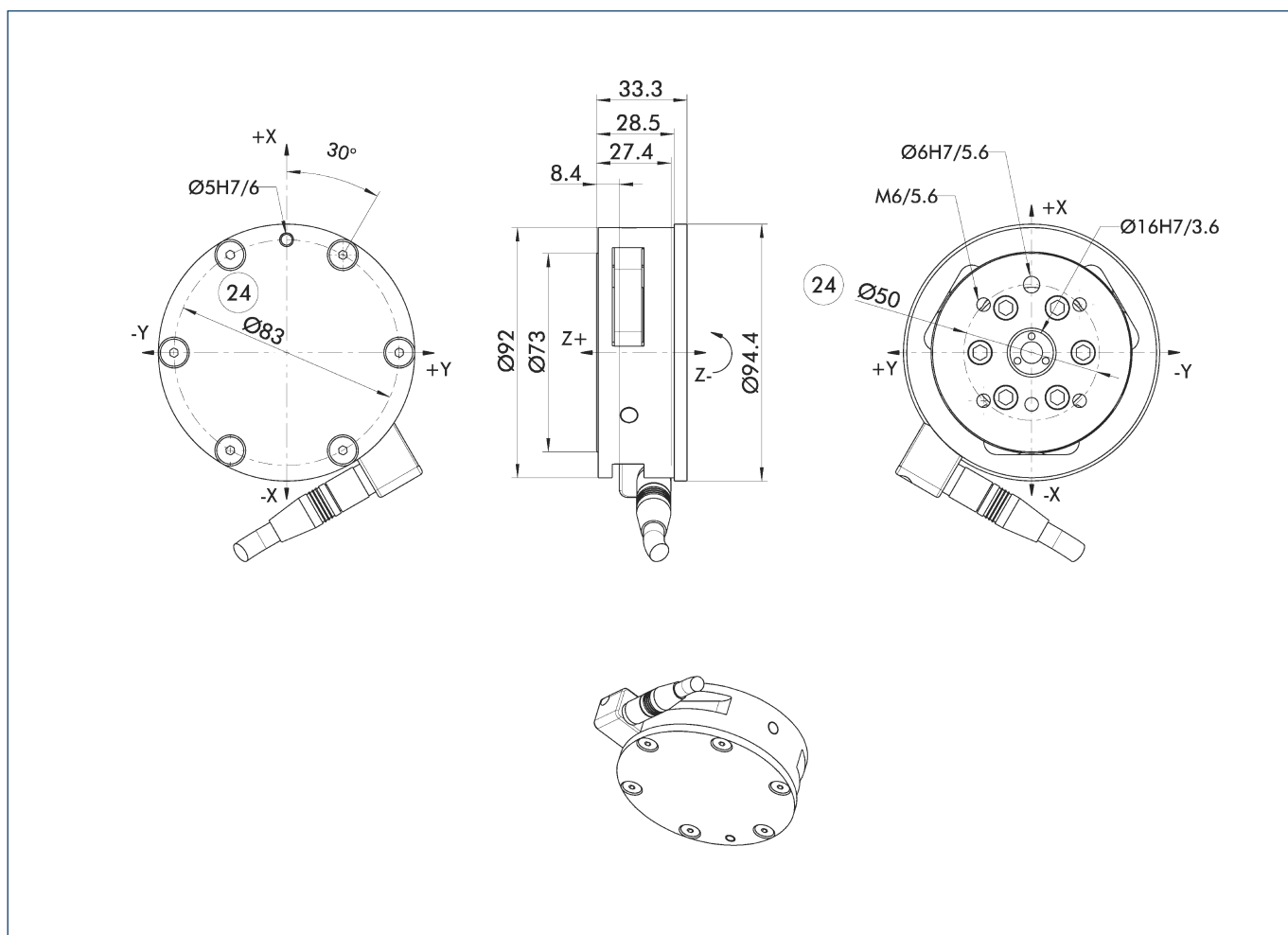

②4 Bolt pitch circle



Product advantages

- Wire eroded measuring element made from high-strength, stainless steel
- Special overload bolts make the Theta an extremely robust transducer
- Up to 20-fold overload safety with respect to the range of measurement

Measurement signal resistant to interference due to use of silicium strain gauges

Silicium strain gauges provide a signal which is 75 times stronger than conventional foil strain gauges. The silicium strain gauges reduce signal noise to practically nothing.

Sensor also available in the following protection classes

IP 60 dust-proof version

IP 65 splash-proof version, suitable for use in damp environments

IP 68 immersion-proof version down to 10 m

For further information or drawings please feel free to contact us. We will be happy to help.

Typical areas of application

- Rehabilitation research
- Robot set-up
- Orthopedics research
- Product tests
- Telerobotics
- Part assembly and machining in precision systems

Technical data

Designation	FTS-Theta	FTD-Theta	FTS-Theta	FTD-Theta	FTS-Theta	FTD-Theta
Calibration	SI-1000-120	SI-1000-120	SI-1500-240	SI-1500-240	SI-2500-400	SI-2500-400
Resolution	Stand alone	DAQ	Stand alone	DAQ	Stand alone	DAQ
Mass [g]	4990	4990	4990	4990	4990	4990
Range of measurement, F_x, F_y [N]	± 1000	± 1000	± 1500	± 1500	± 2500	± 2500
Range of measurement, F_z [N]	± 2500	± 2500	± 3750	± 3750	± 6250	± 6250
Range of measurement, M_x, M_y [Nm]	± 120	± 120	± 240	± 240	± 400	± 400
Range of measurement, M_z [Nm]	± 120	± 120	± 240	± 240	± 400	± 400
Resolution, F_x, F_y [N]	± 1/2	± 1/16	± 1	± 1/8	± 1	± 1/8
Resolution, F_z [N]	± 1/2	± 1/16	± 1	± 1/8	± 3/2	± 1/4
Resolution, M_x, M_y [N]	± 1/40	± 1/160	± 1/20	± 3/80	± 1/10	± 1/80
Resolution, M_z [Nm]	± 1/40	± 1/320	± 1/20	± 3/160	± 1/10	± 1/80
Overload, F_{xy} [N]	± 25000	± 25000	± 25000	± 25000	± 25000	± 25000
Overload, F_z [N]	± 61000	± 61000	± 61000	± 61000	± 61000	± 61000
Overload, T_{xy} [Nm]	± 2490	± 2490	± 2490	± 2490	± 2490	± 2490
Overload, T_z [Nm]	± 2680	± 2680	± 2680	± 2680	± 2680	± 2680
Rigidity, force XY axis (KF_x, KF_y) [N/m]	73×10^6	73×10^6	73×10^6	73×10^6	73×10^6	73×10^6
Rigidity, Z axis (KF_z) [N/m]	125×10^6	125×10^6	125×10^6	125×10^6	125×10^6	125×10^6
Rigidity, force XY axis (KM_x, KM_y) [Nm/rad]	3.4×10^3	3.4×10^3	3.4×10^3	3.4×10^3	3.4×10^3	3.4×10^3
Rigidity, Z axis (KM_z) [Nm/rad]	5.4×10^3	5.4×10^3	5.4×10^3	5.4×10^3	5.4×10^3	5.4×10^3
Resonance, frequency F_x, F_y, M_z [KHz]	0.68	0.68	0.68	0.68	0.68	0.68
Resonance, frequency F_z, M_x, M_y [KHz]	0.82	0.82	0.82	0.82	0.82	0.82

Main views

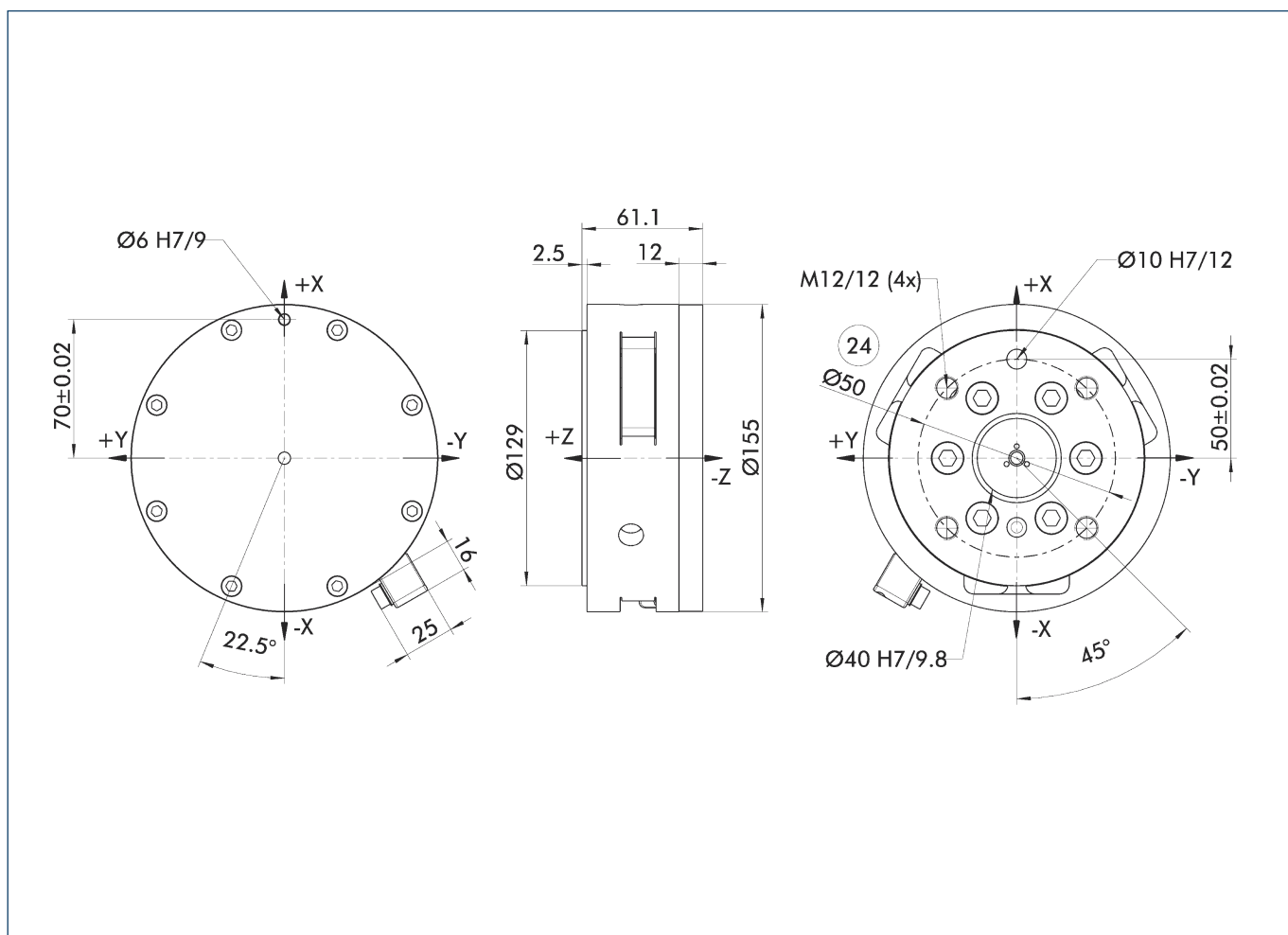

②4 Bolt pitch circle



Product advantages

Industrial

- 40 mm center bore, freely usable

Robust and compact

- Wire eroded measuring element made from high-strength, stainless steel
- Up to 14-fold overload safety with respect to the range of measurement

Measurement signal resistant to interference due to use of silicium strain gauges

Silicium strain gauges provide a signal which is 75 times stronger than conventional foil strain gauges. The silicium strain gauges reduce signal noise to practically nothing.

Sensor also available in the following protection classes

IP 60 dust-proof version

IP 65 splash-proof version, suitable for use in damp environments

IP 68 immersion-proof version down to 10 m

For further information or drawings please feel free to contact us. We will be happy to help.

Typical areas of application

- Rehabilitation research
- Robot set-up
- Orthopedics research
- Product tests
- Telerobotics
- Part assembly and machining in precision systems

Technical data

Designation	FTS-Omega-160	FTD-Omega-160	FTS-Omega-160	FTD-Omega-160	FTS-Omega-160	FTD-Omega-160
Calibration	SI-1000-120	SI-1000-120	SI-1500-240	SI-1500-240	SI-2500-400	SI-2500-400
Resolution	Stand alone	DAQ	Stand alone	DAQ	Stand alone	DAQ
Mass [g]	2720	2720	2720	2720	2720	2720
Range of measurement, F_x, F_y [N]	± 1000	± 1000	± 1500	± 1500	± 2500	± 2500
Range of measurement, F_z [N]	± 2500	± 2500	± 3750	± 3750	± 6250	± 6250
Range of measurement, M_x, M_y [Nm]	± 120	± 120	± 240	± 240	± 400	± 400
Range of measurement, M_z [Nm]	± 120	± 120	± 240	± 240	± 400	± 400
Resolution, F_x, F_y [N]	± 1/4	± 1/16	± 1/2	± 1/8	± 1	± 1/8
Resolution, F_z [N]	± 1/2	± 1/16	± 1	± 1/8	± 3/2	± 3/16
Resolution, M_x, M_y [N]	± 1/40	± 1/160	± 1/20	± 3/80	± 1/10	± 1/80
Resolution, M_z [Nm]	± 1/40	± 1/320	± 1/20	± 3/160	± 1/10	± 1/80
Overload, F_{xy} [N]	± 17500	± 17500	± 17500	± 17500	± 17500	± 17500
Overload, F_z [N]	± 48000	± 48000	± 48000	± 48000	± 48000	± 48000
Overload, T_{xy} [Nm]	± 1730	± 1730	± 1730	± 1730	± 1730	± 1730
Overload, T_z [Nm]	± 1890	± 1890	± 1890	± 1890	± 1890	± 1890
Rigidity, force XY axis (KF_x, KF_y) [N/m]	70×10^6	70×10^6	70×10^6	70×10^6	70×10^6	70×10^6
Rigidity, Z axis (KF_z) [N/m]	119×10^6	119×10^6	119×10^6	119×10^6	119×10^6	119×10^6
Rigidity, force XY axis (KM_x, KM_y) [Nm/rad]	3.3×10^3	3.3×10^3	3.3×10^3	3.3×10^3	3.3×10^3	3.3×10^3
Rigidity, Z axis (KM_z) [Nm/rad]	5.3×10^3	5.3×10^3	5.3×10^3	5.3×10^3	5.3×10^3	5.3×10^3
Resonance, frequency F_x, F_y, M_z [KHz]	1.3	1.3	1.3	1.3	1.3	1.3
Resonance, frequency F_z, M_x, M_y [KHz]	1	1	1	1	1	1

Main views

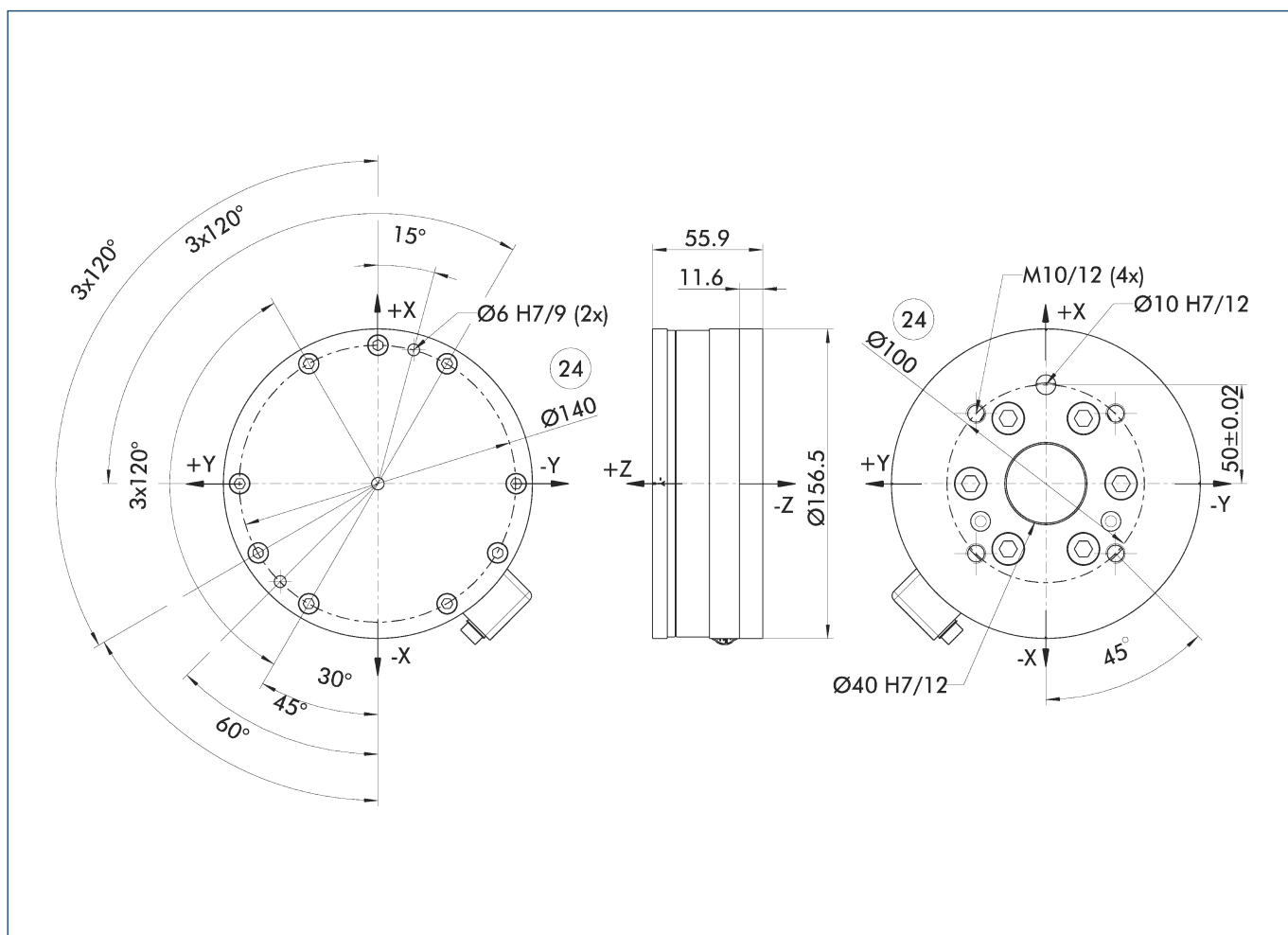

⌀24 Bolt pitch circle





Product advantages

Robust and compact

- Wire eroded measuring element made from high-strength, stainless steel
- Up to 14-fold overload safety with respect to the range of measurement

Measurement signal resistant to interference due to use of silicium strain gauges

Silicium strain gauges provide a signal which is 75 times stronger than conventional foil strain gauges. The silicium strain gauges reduce signal noise to practically nothing.

Sensor also available in the following protection classes

IP 60 dust-proof version

IP 65 splash-proof version, suitable for use in damp environments

IP 68 immersion-proof version down to 10 m

For further information or drawings please feel free to contact us. We will be happy to help.

Typical areas of application

- Product tests
- Telerobotics
- Load feedback
- Part assembly and machining in precision systems

Technical data

Designation	FTS-Omega-190	FTD-Omega-190	FTS-Omega-190	FTD-Omega-190	FTS-Omega-190	FTD-Omega-190
Calibration	SI-1800-350	SI-1800-350	SI-3600-700	SI-3600-700	SI-7200-1400	SI-7200-1400
Resolution	Stand alone	DAQ	Stand alone	DAQ	Stand alone	DAQ
Mass [g]	6.35	6.35	6.35	6.35	6.35	6.35
Range of measurement, F_x, F_y [N]	± 1800	± 1800	± 3600	± 3600	± 7200	± 7200
Range of measurement, F_z [N]	± 4500	± 4500	± 9000	± 9000	± 18000	± 18000
Range of measurement, M_x, M_y [Nm]	± 350	± 350	± 700	± 700	± 1400	± 1400
Range of measurement, M_z [Nm]	± 350	± 350	± 700	± 700	± 1400	± 1400
Resolution, F_x, F_y [N]	± 3/4	± 3/32	± 3/2	± 3/16	± 3	± 3/8
Resolution, F_z [N]	± 3/2	± 5/32	± 3	± 5/16	± 6	± 5/8
Resolution, M_x, M_y [N]	± 5/48	± 5/384	± 5/24	± 5/192	± 5/12	± 5/96
Resolution, M_z [Nm]	± 5/72	± 5/576	± 5/36	± 5/288	± 5/18	± 5/144
Overload, F_{xy} [N]	± 35700	± 35700	± 35700	± 35700	± 35700	± 35700
Overload, F_z [N]	± 111000	± 111000	± 111000	± 111000	± 111000	± 111000
Overload, T_{xy} [Nm]	± 5500	± 5500	± 5500	± 5500	± 5500	± 5500
Overload, T_z [Nm]	± 8100	± 8100	± 8100	± 8100	± 8100	± 8100
Rigidity, force XY axis (KF_x, KF_y) [N/m]	252×10^6	252×10^6	252×10^6	252×10^6	252×10^6	252×10^6
Rigidity, Z axis (KF_z) [N/m]	369×10^6	369×10^6	369×10^6	369×10^6	369×10^6	369×10^6
Rigidity, force XY axis (KM_x, KM_y) [Nm/rad]	1.575×10^3	1.575×10^3	1.575×10^3	1.575×10^3	1.575×10^3	1.575×10^3
Rigidity, Z axis (KM_z) [Nm/rad]	3.331×10^3	3.331×10^3	3.331×10^3	3.331×10^3	3.331×10^3	3.331×10^3

Main views

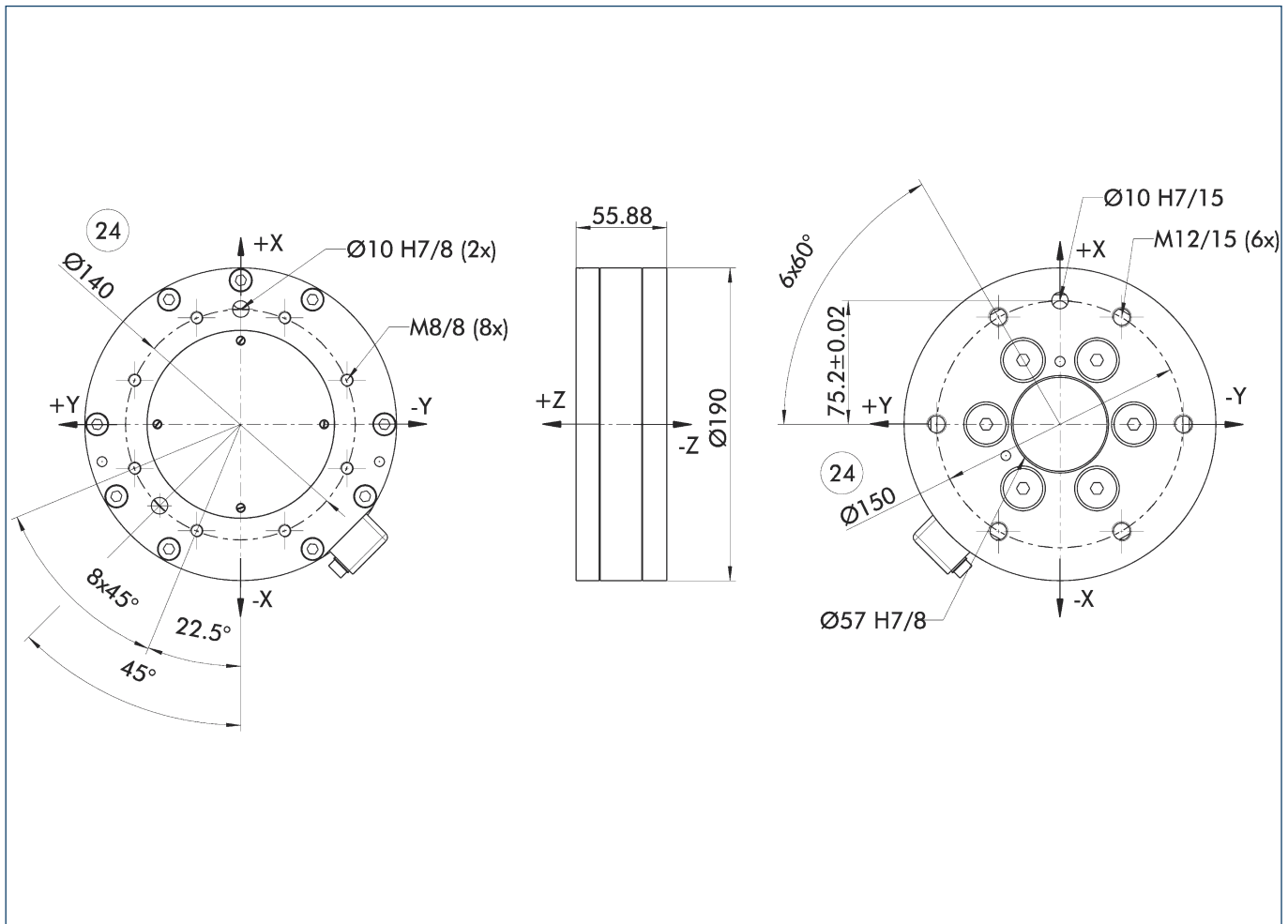

24 Bolt pitch circle



Product advantages

Robust and compact

- Wire eroded measuring element made from high-strength, stainless steel
- Up to 14-fold overload safety with respect to the range of measurement

Measurement signal resistant to interference due to use of silicium strain gauges

Silicium strain gauges provide a signal which is 75 times stronger than conventional foil strain gauges. The silicium strain gauges reduce signal noise to practically nothing.

Sensor also available in the following protection classes

IP 60 dust-proof version

IP 65 splash-proof version, suitable for use in damp environments

IP 68 immersion-proof version down to 10 m

For further information or drawings please feel free to contact us. We will be happy to help.

Typical areas of application

- Product tests
- Telerobotics
- Load feedback
- Part assembly and machining in precision systems

Technical data

Designation	FTS-Omega-250	FTD-Omega-250	FTS-Omega-250	FTD-Omega-250	FTS-Omega-250	FTD-Omega-250
Calibration	SI-4000-500	SI-4000-500	SI-8000-1000	SI-8000-1000	SI-16000-2000	SI-16000-2000
Resolution	Stand alone	DAQ	Stand alone	DAQ	Stand alone	DAQ
Mass [g]	30	30	30	30	30	30
Range of measurement, F_x, F_y [N]	± 4000	± 4000	± 8000	± 8000	± 16000	± 16000
Range of measurement, F_z [N]	± 8000	± 8000	± 16000	± 16000	± 32000	± 32000
Range of measurement, M_x, M_y [Nm]	± 500	± 500	± 1000	± 1000	± 2000	± 2000
Range of measurement, M_z [Nm]	± 500	± 500	± 1000	± 1000	± 2000	± 2000
Resolution, F_x, F_y [N]	± 1 3/4	± 7/32	± 3 1/2	± 7/16	± 7	± 7/8
Resolution, F_z [N]	± 2 3/4	± 11/32	± 5 1/2	± 11/16	± 11	± 1 3/8
Resolution, M_x, M_y [N]	± 7/32	± 7/256	± 7/16	± 7/28	± 7/8	± 7/64
Resolution, M_z [Nm]	± 3/16	± 3/128	± 3/8	± 3/64	± 3/4	± 3/32
Overload, F_{xy} [N]	± 160000	± 160000	± 160000	± 160000	± 160000	± 160000
Overload, F_z [N]	± 320000	± 320000	± 320000	± 320000	± 320000	± 320000
Overload, T_{xy} [Nm]	± 20000	± 20000	± 20000	± 20000	± 20000	± 20000
Overload, T_z [Nm]	± 24000	± 24000	± 24000	± 24000	± 24000	± 24000
Rigidity, force XY axis (KF_x, KF_y) [N/m]	420 x 10 ⁶	420 x 10 ⁶	420 x 10 ⁶	420 x 10 ⁶	420 x 10 ⁶	420 x 10 ⁶
Rigidity, Z axis (KF_z) [N/m]	550 x 10 ⁶	550 x 10 ⁶	550 x 10 ⁶	550 x 10 ⁶	550 x 10 ⁶	550 x 10 ⁶
Rigidity, force XY axis (KM_x, KM_y) [Nm/rad]	3.0 x 10 ⁶	3.0 x 10 ⁶	3.0 x 10 ⁶	3.0 x 10 ⁶	3.0 x 10 ⁶	3.0 x 10 ⁶
Rigidity, Z axis (KM_z) [Nm/rad]	6.2 x 10 ⁶	6.2 x 10 ⁶	6.2 x 10 ⁶	6.2 x 10 ⁶	6.2 x 10 ⁶	6.2 x 10 ⁶

Main views

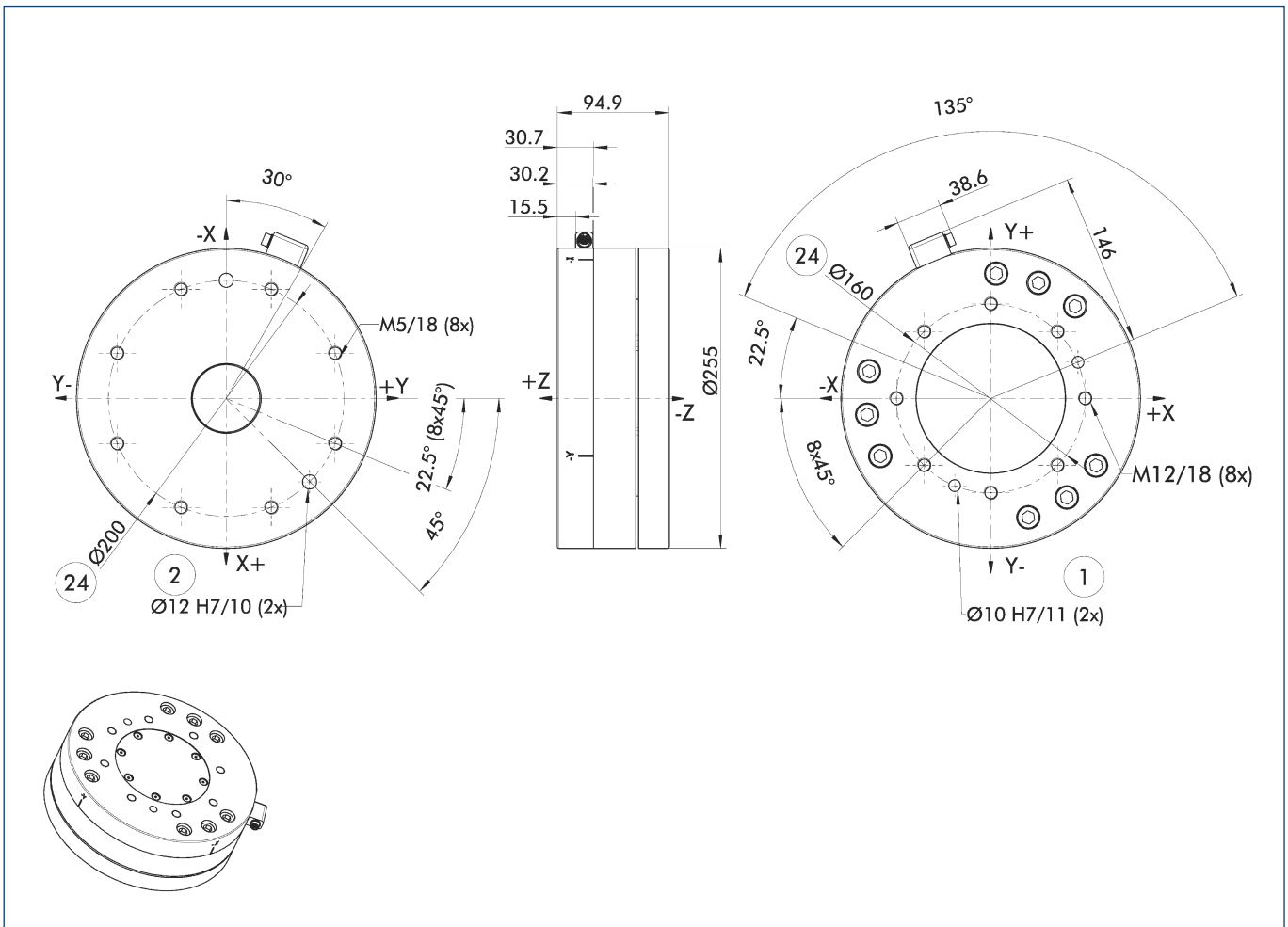

- ① Robot-side connection
- ② Tool-side connection
- ⑳ Bolt pitch circle

Machining



MACHINING

Series	Size	Page
Deburring Spindle		
FDB		440
FDB	150	444
FDB	300	448
FDB	340	452
FDB	660	456





Sizes
150 .. 660

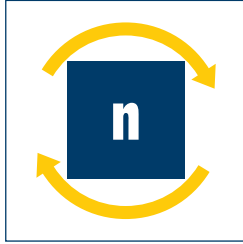

Max. speed
65000 RPM



Power consumption
150 W .. 660 W

Application example

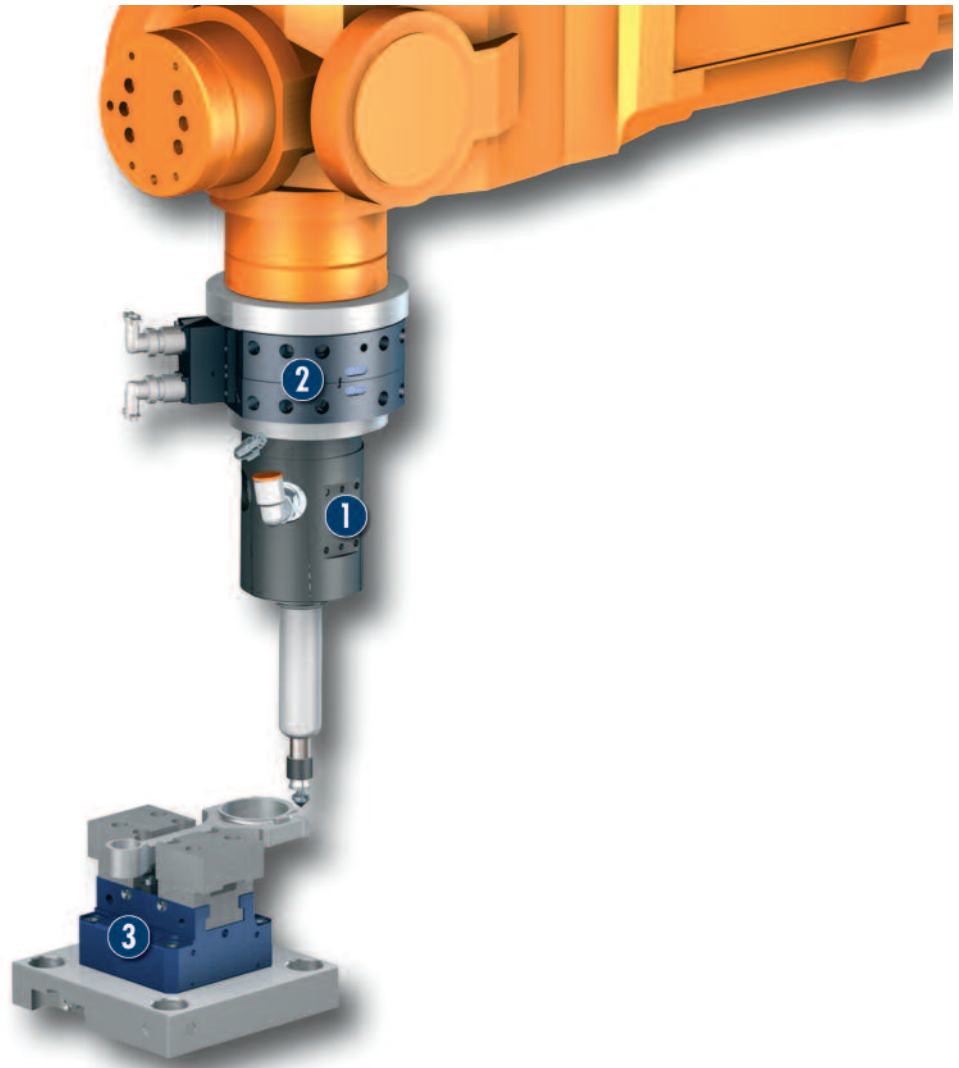

Robot-controlled deburring of case connecting rods

Flexible Deburring Spindle FDB 300

Clamping Force Block KSP 100

Quick-change System SWS 41

Deburring Spindle

Flexible deburring spindle for use on robot

Area of application

Standard solution for flexible and robot-controlled deburring of various workpieces

Your advantages and benefits

Flexible high-frequency spindle

for maximum flexibility during deburring

Adjustable rigidity of spindle

for clean chamfering edges in any installation position

High RPMs

for fast feed rates

Flexible use

on robot arm or as a stationary unit



General information on the series

Mounting

on back or side

Drive

quiet-running compressed air spindle (less than 70 dbA)

Scope of delivery

spindle with collet and pneumatic screw connection

Warranty

24 months

Actuation

pneumatic, via filtered compressed air (10 µm): dry and non-lubricated

Sectional diagram

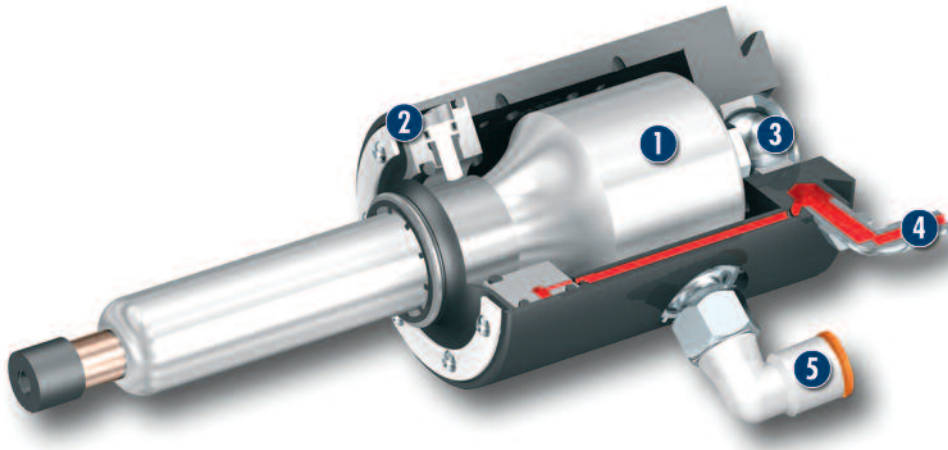

Pneumatic Spindle

High-performance spindle up to 65,000 RPM

Ring Cylinder

for adapting the pressure force to the workpiece

Bearing Point

of the pendulum suspension of the pneumatic motor

Air Connection

for actuation of the ring cylinder

Air Connection

with large diameter for pneumatic motor

Functional description

The unit is driven by a pneumatic spindle with a speed of up to 65,000 RPM depending on the size. The spindle is mounted on pendulum bearings in order to follow tolerances of the machining contour. The maximum path at the milling tip is +/- 9 mm. The force (rigidity) needed for the pendulum motion of the spindle is regulated via a second air connection. Depending on the pressure, a force of 3.1 N to 42.3 N is applied to the cutting surface.

Options and special information

Universal

Due to flexible mounting options, the FDB is not restricted to use on the robot arm. It can also be used as a permanently mounted tool with a moving workpiece.

Accessories

Accessories from SCHUNK - the suitable supplement for maximum functionality, reliability and performance of all automation modules.

Collets



Adapter plates



Fittings



General information on the series

Please note that the unit is not suitable for use with coolants.





Forces and moments

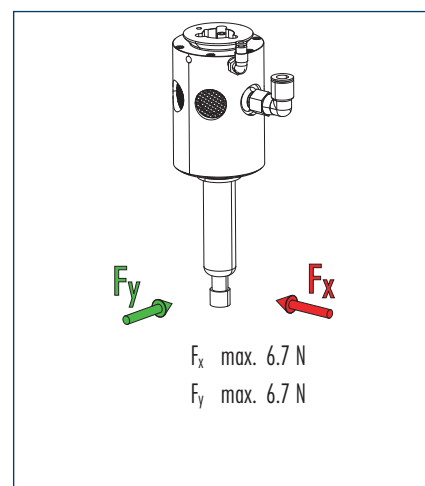

Technical data

Designation	FDB 150	
	ID	0322200
Weight	[kg]	1.11
Max. compensation path	[mm]	5.0
Recommended compensation path	[mm]	2.5
Min. compensation force	[N]	3.1
Max. compensation force	[N]	6.7
Min. compensation pressure	[bar]	1.4
Max. compensation pressure	[bar]	4.1
No-load speed	[RPM]	65000
Air consumption without load	[l/s]	1.4
Air consumption blocked	[l/s]	3.8
Collet diameter	[mm]	3.0
Power	[W]	150.0

Main views

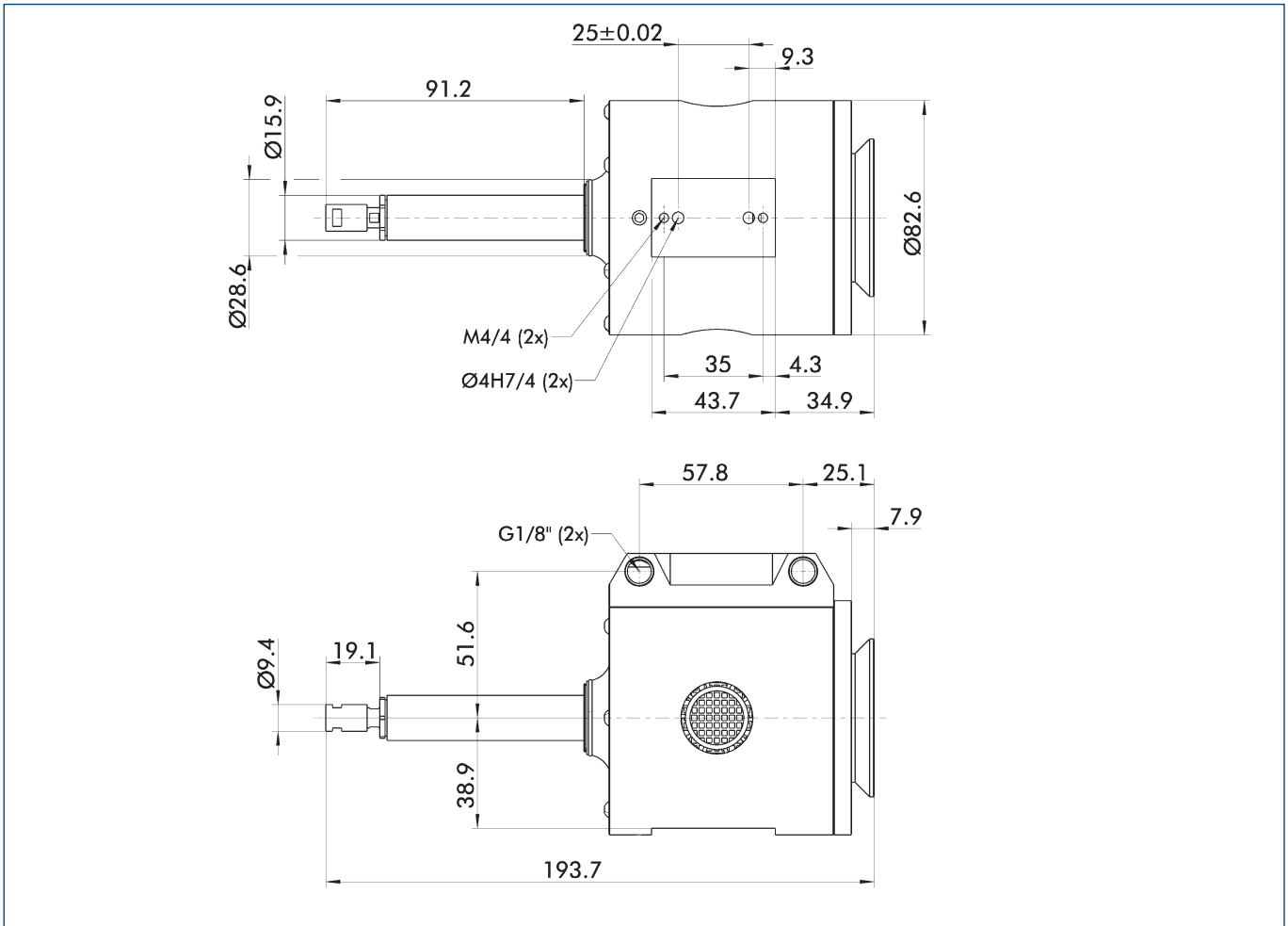

The drawing shows the basic version of the deburring spindle without dimensional consideration of the options described below.

Adapter plates, radial

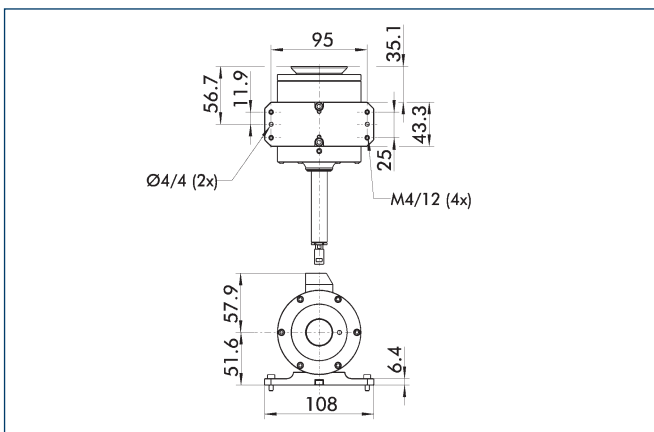

Designation	ID
FDB-APL-1054	0322212

Adapter plates, axial

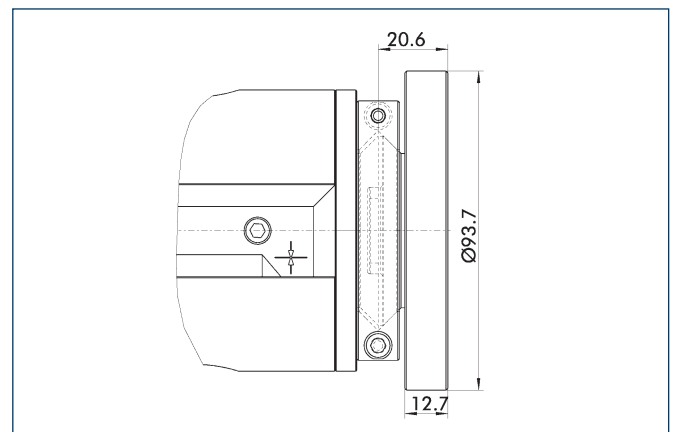

Designation	ID
FDB-APL-1005	0322210

Collets

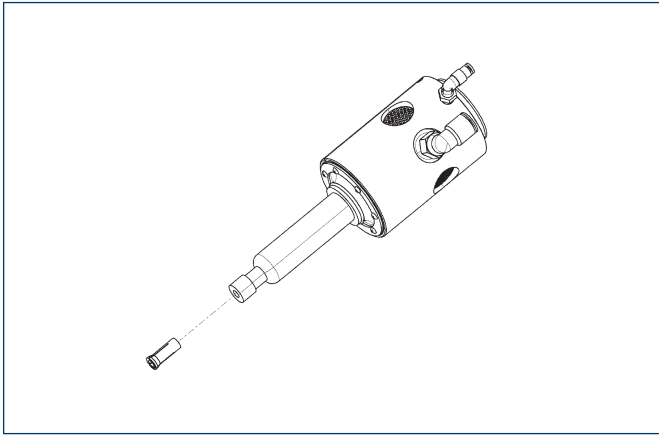

Designation	ID	Diameter
Collets FDB-C-12142	0322221	3 mm
Collets FDB-C-12149	0322224	1/8 "

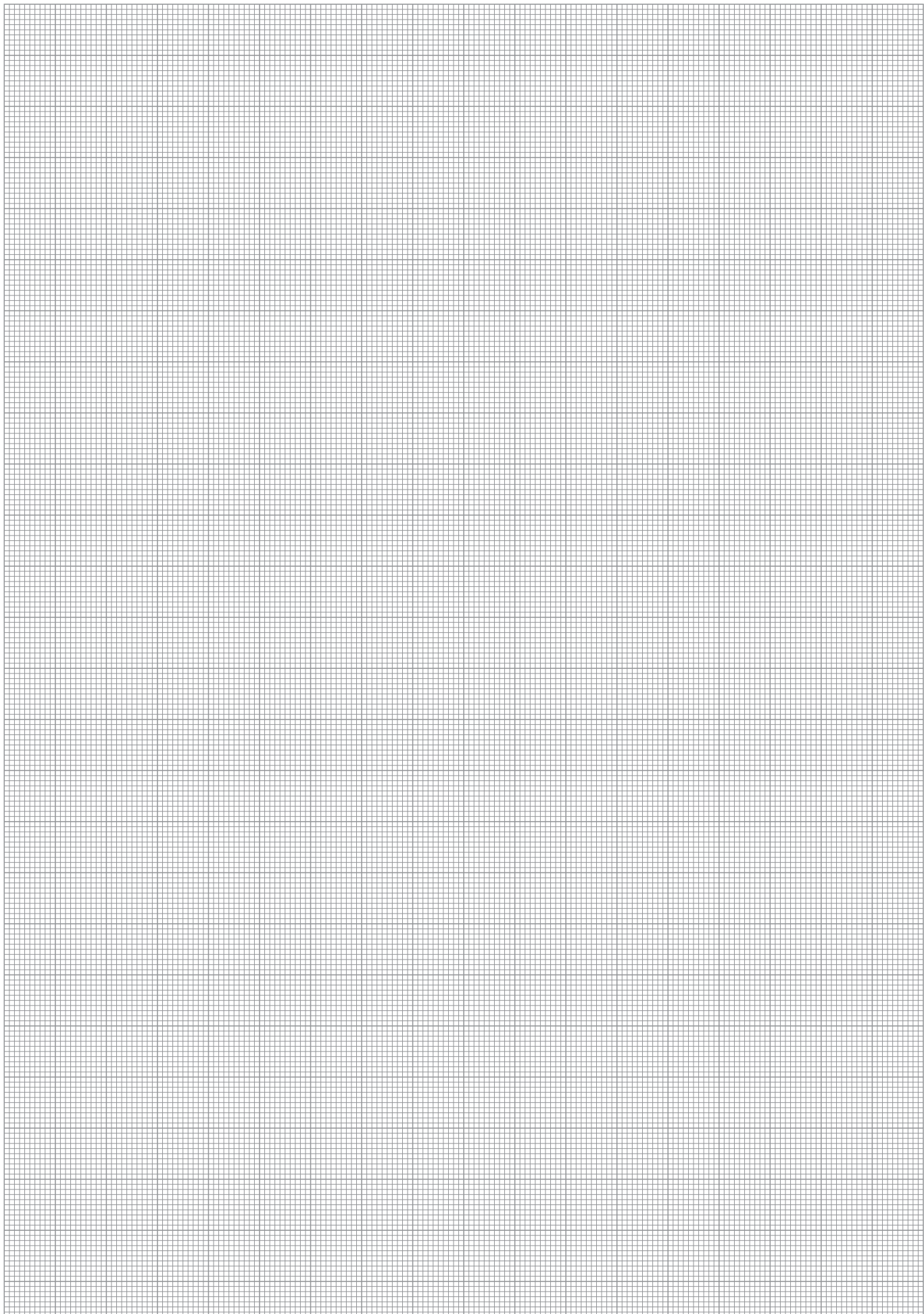



Forces and moments

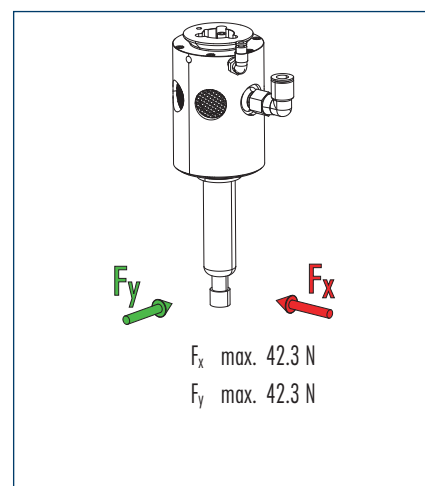

Technical data

Designation	FDB 300	
	ID	0322202
Weight	[kg]	1.15
Max. compensation path	[mm]	8.0
Recommended compensation path	[mm]	4.0
Min. compensation force	[N]	6.7
Max. compensation force	[N]	42.3
Min. compensation pressure	[bar]	0.3
Max. compensation pressure	[bar]	4.1
No-load speed	[RPM]	30000
Air consumption without load	[l/s]	2.8
Air consumption blocked	[l/s]	10.2
Collet diameter	[mm]	6.0
Power	[W]	300.0

Main views

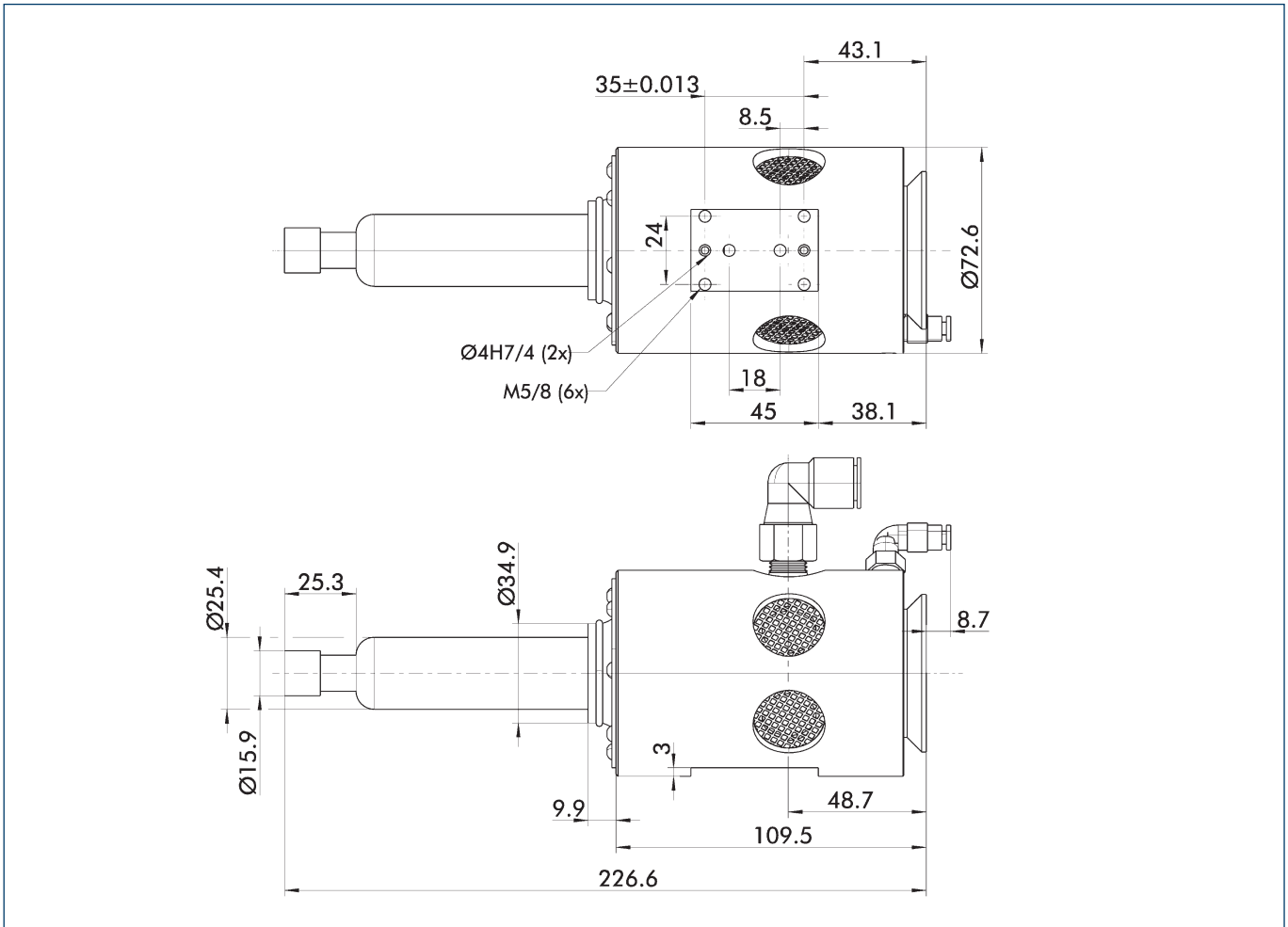

The drawing shows the basic version of the deburring spindle without dimensional consideration of the options described below.

Adapter plates, radial

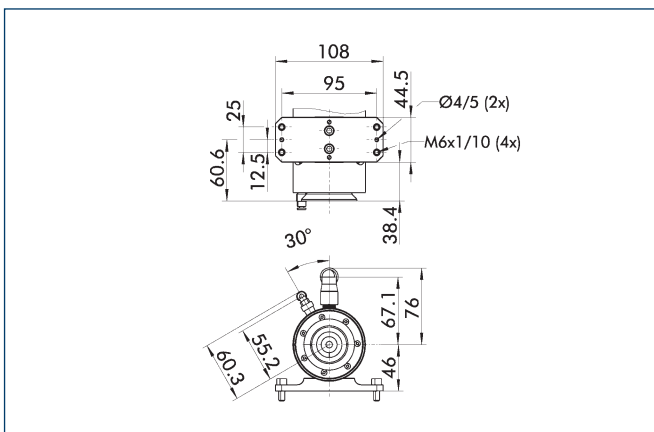

Adapter plates, axial

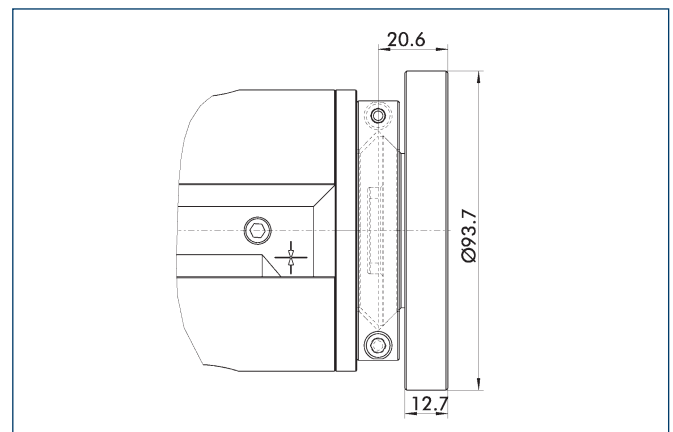

Collets

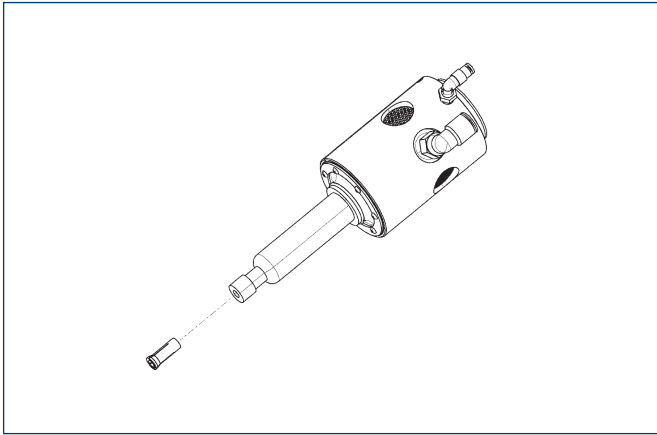

Designation	ID	Diameter
Collets FDB-C-12442	0322220	3 mm
Collets FDB-C-12443	0322226	1/8 "
Collets FDB-C-12445	0322222	6 mm
Collets FDB-C-12446	0322225	1/4 "

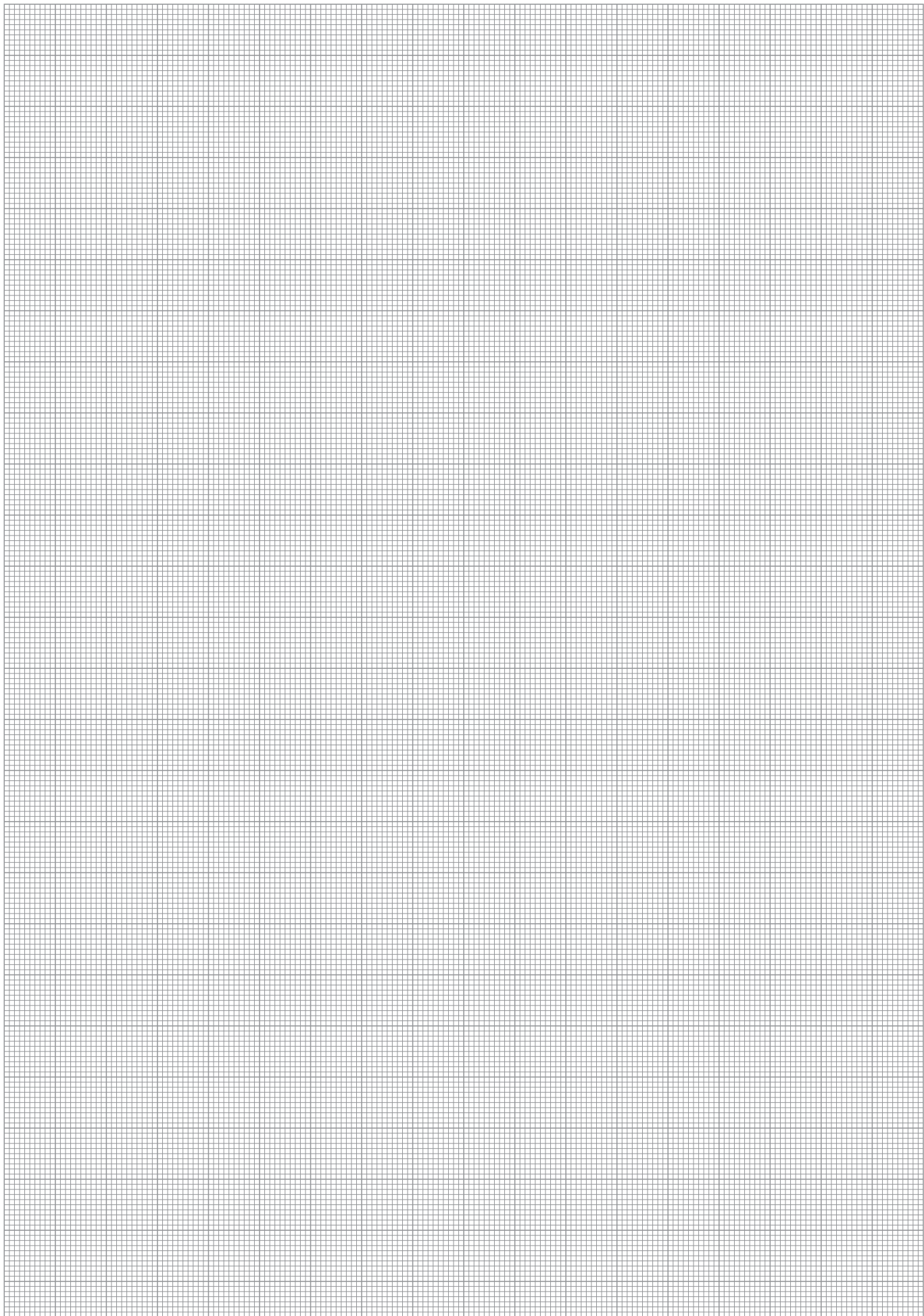



Forces and moments

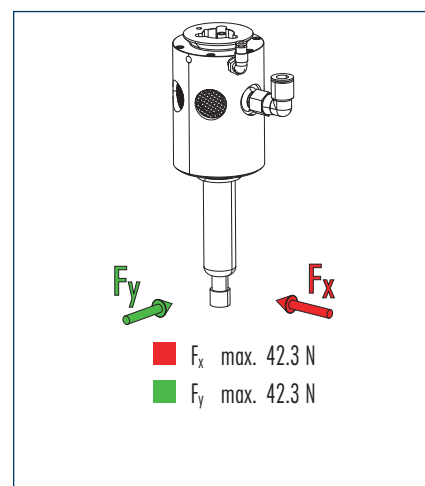

Technical data

Designation	FDB 340	
	ID	0322201
Weight	[kg]	1.15
Max. compensation path	[mm]	8.0
Recommended compensation path	[mm]	4.0
Min. compensation force	[N]	6.7
Max. compensation force	[N]	42.3
Min. compensation pressure	[bar]	0.3
Max. compensation pressure	[bar]	4.1
No-load speed	[RPM]	40000
Air consumption without load	[l/s]	2.8
Air consumption blocked	[l/s]	10.2
Collet diameter	[mm]	6.0
Power	[W]	340.0

Main views

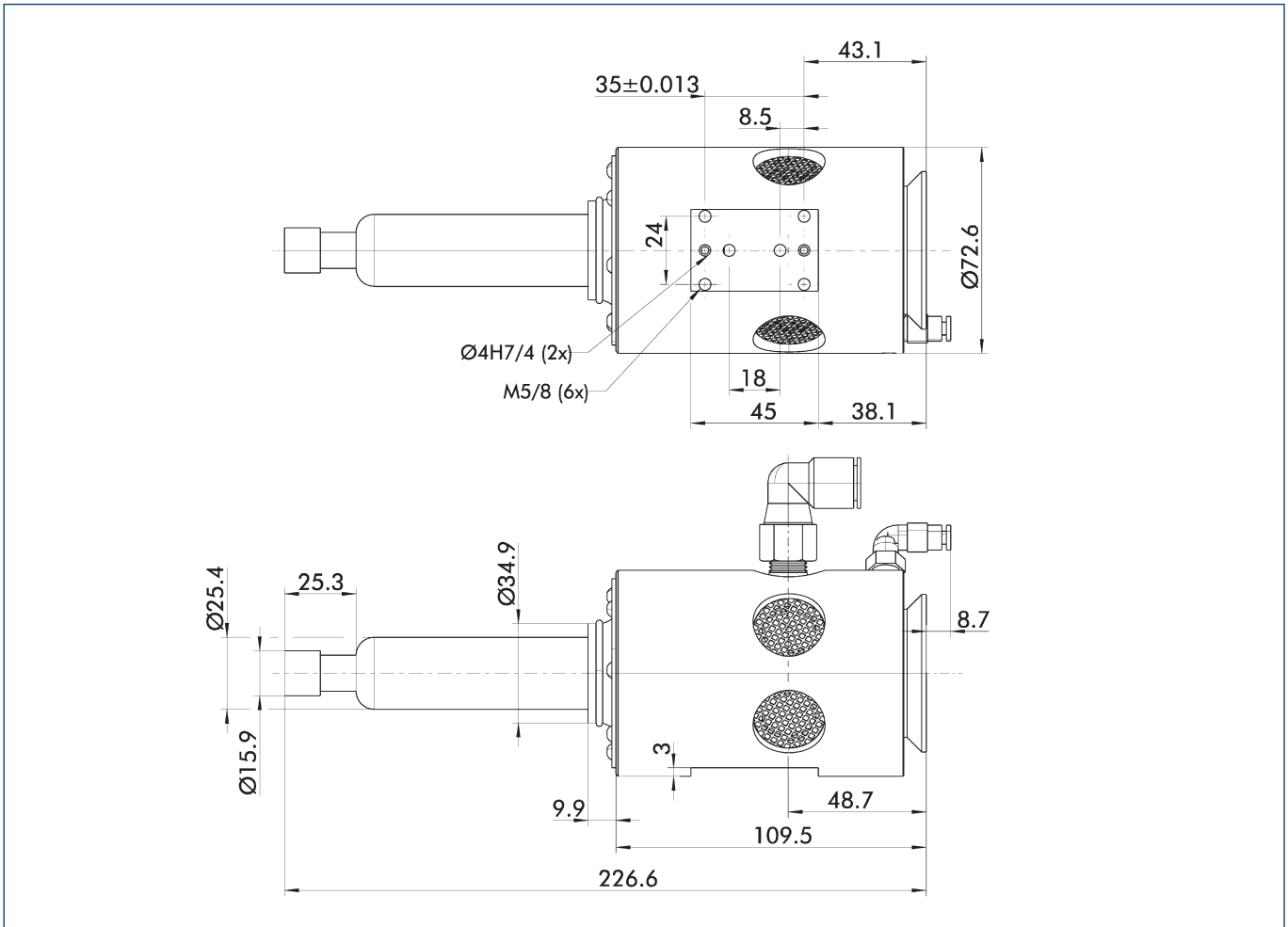

The drawing shows the basic version of the deburring spindle without dimensional consideration of the options described below.

Adapter plates, radial

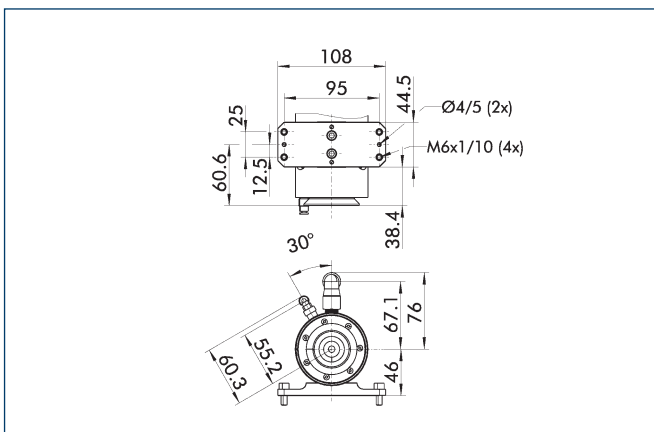

Designation	ID
FDB-APL-1003	0322213

Adapter plates, axial

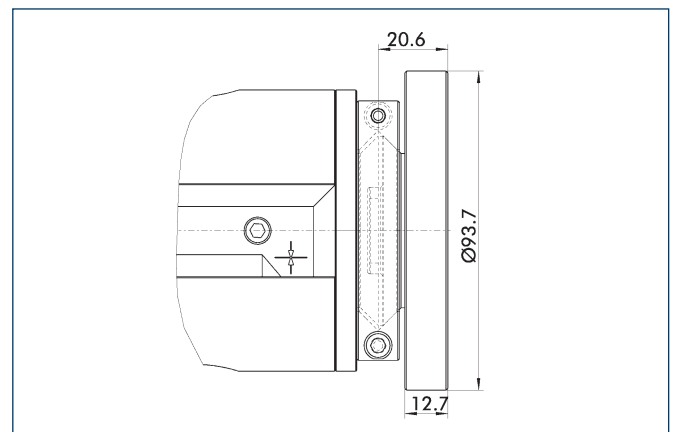

Designation	ID
FDB-APL-1005	0322210

Collets

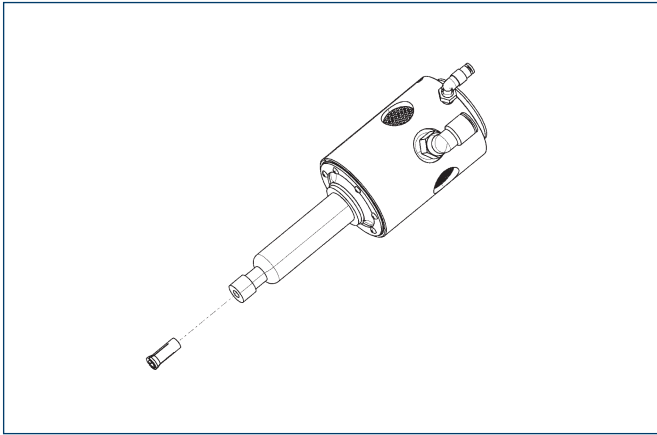

Designation	ID	Diameter
Collets FDB-C-12442	0322220	3 mm
Collets FDB-C-12443	0322226	1/8 "
Collets FDB-C-12445	0322222	6 mm
Collets FDB-C-12446	0322225	1/4 "

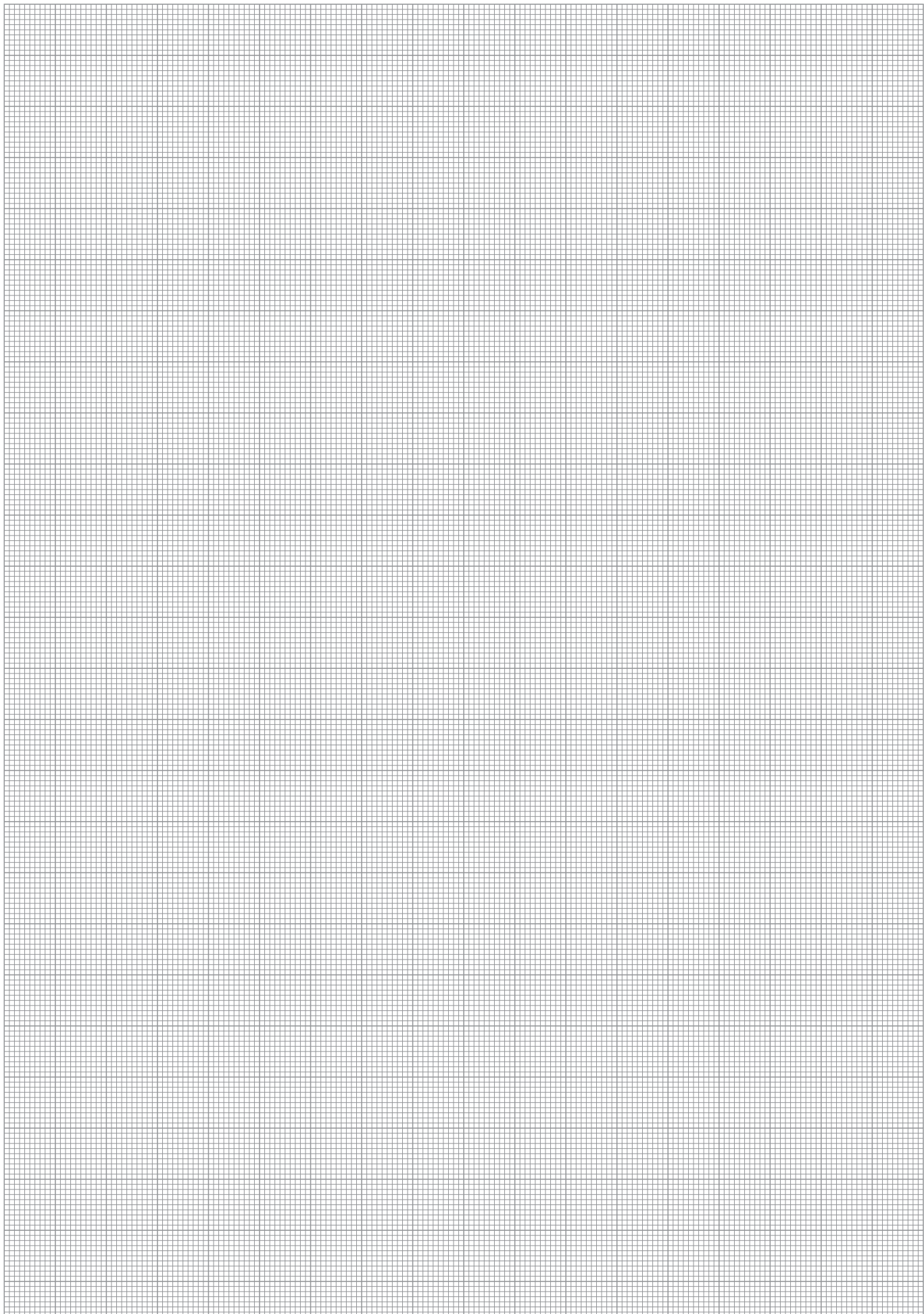



Forces and moments

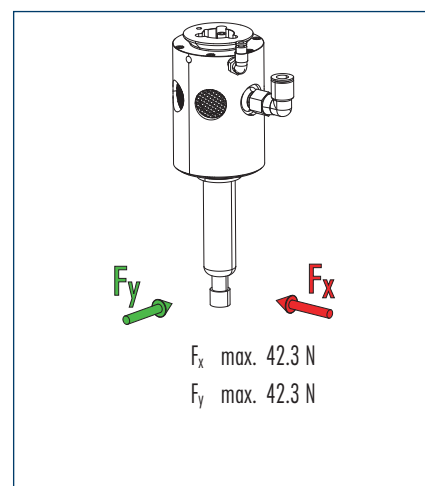

Technical data

Designation	ID	FDB 660
Weight	[kg]	2.2
Max. compensation path	[mm]	9.0
Recommended compensation path	[mm]	4.5
Min. compensation force	[N]	6.7
Max. compensation force	[N]	42.3
Min. compensation pressure	[bar]	0.3
Max. compensation pressure	[bar]	4.1
No-load speed	[RPM]	40000
Air consumption without load	[l/s]	5.4
Air consumption blocked	[l/s]	17.9
Collet diameter	[mm]	6.0
Power	[W]	660.0

Main views

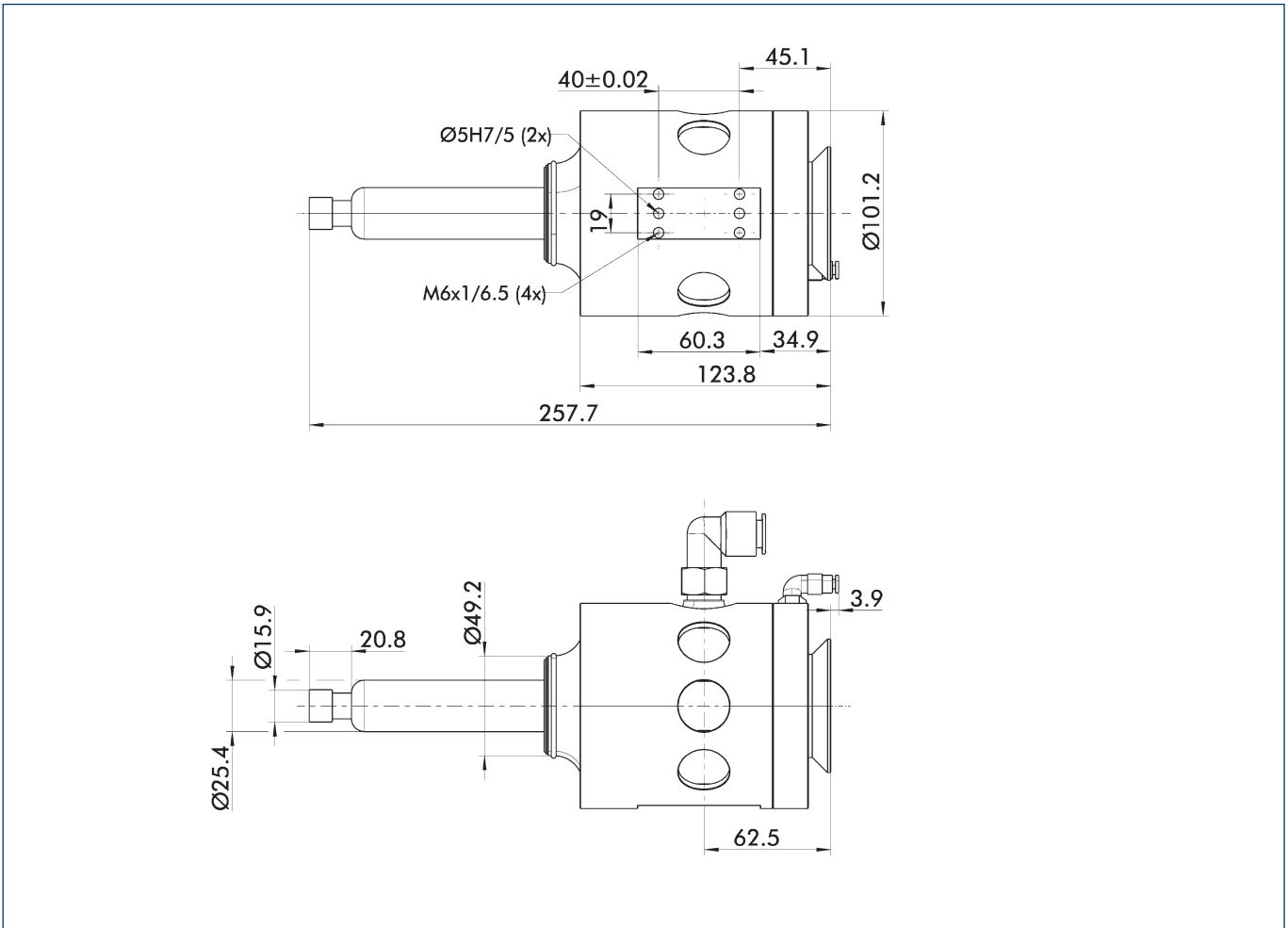

The drawing shows the basic version of the deburring spindle without dimensional consideration of the options described below.

Adapter plates, radial

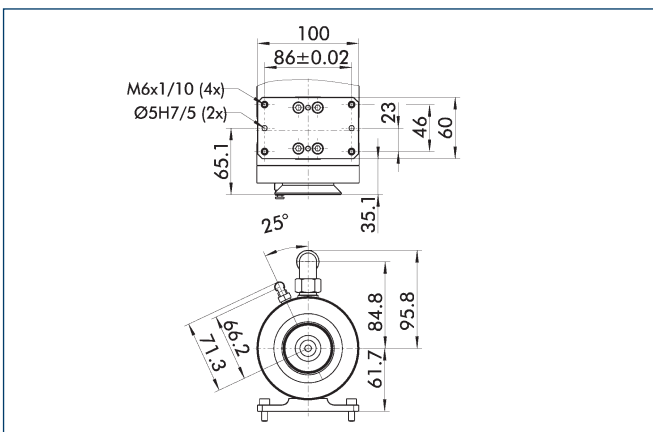

Designation	ID
FDB-APL-1029	0322214

Adapter plates, axial

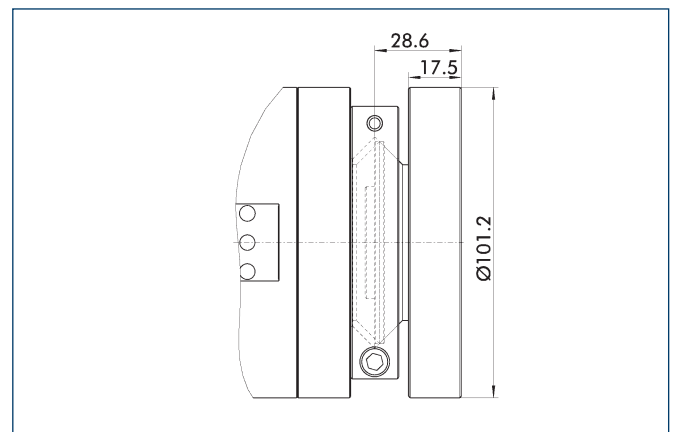

Designation	ID
FDB-APL-1028	0322211

Collets

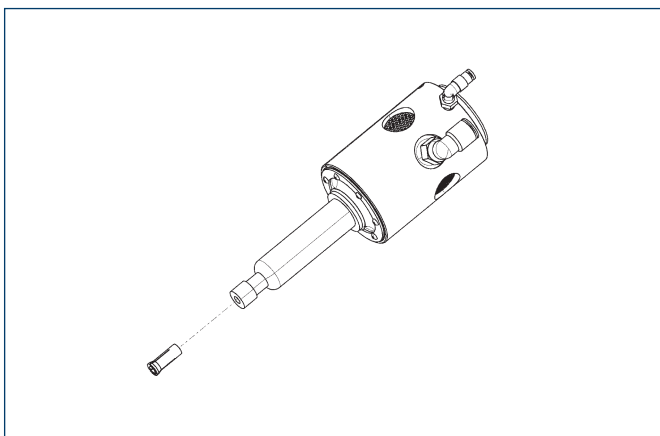

Designation	ID	Diameter
Collets FDB-C-12442	0322220	3 mm
Collets FDB-C-12443	0322226	1/8 "
Collets FDB-C-12445	0322222	6 mm
Collets FDB-C-12446	0322225	1/4 "

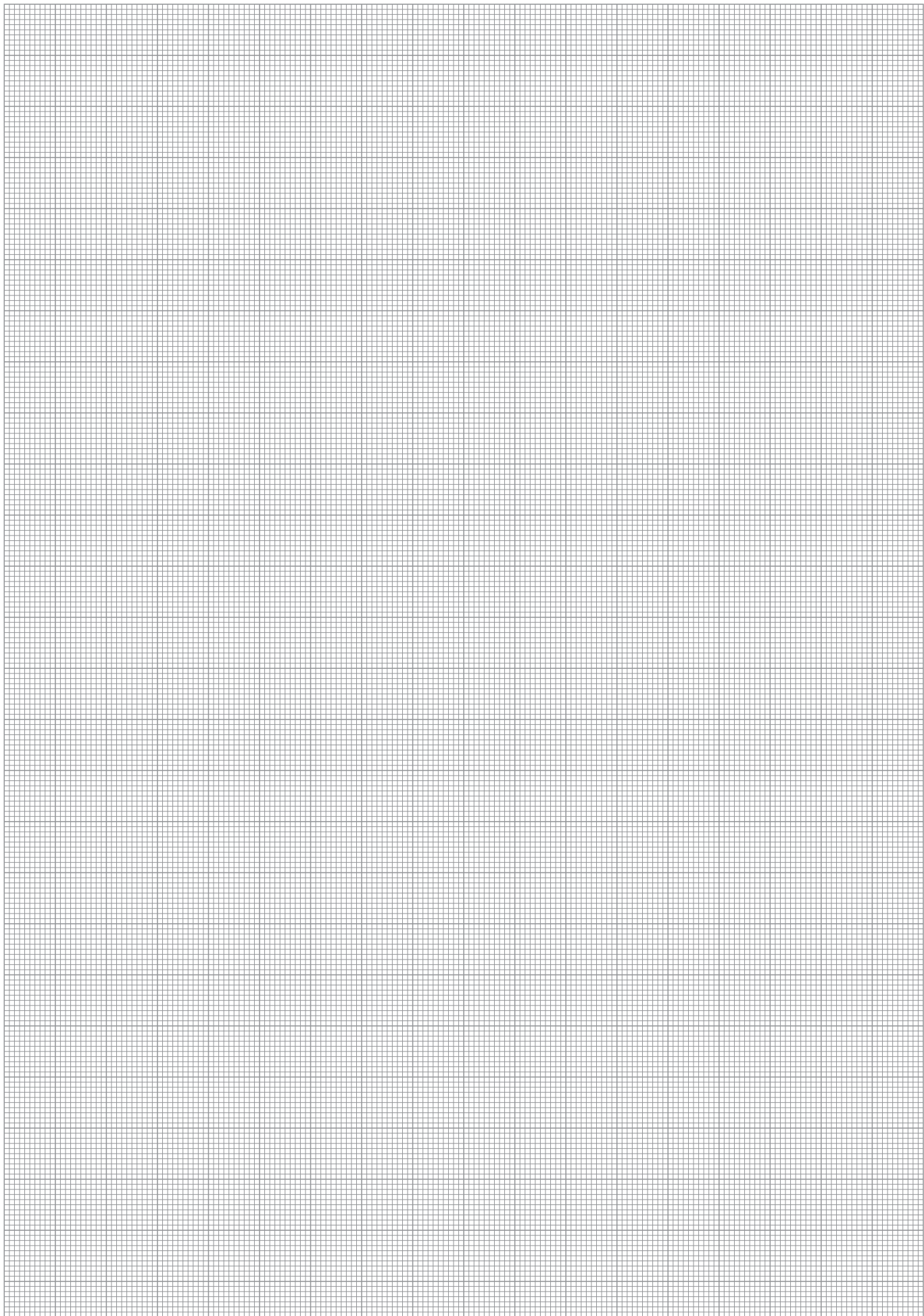

Accessories



ACCESSORIES

Series	Size	Page
Accessories		
Inductive Proximity Switches IN		462
IN	40	464
IN	60	466
IN	65	468
IN	80	470
IN	B-80/80SL	472
Magnetic Switches MMS		474
MMS	22	476
MMS	22-SA	478
Switch Accessories SST		480
SST		482
Valves and Screw Connections		484
VV-G		486
SWV		488
DSV		490



Inductive Proximity Switches

Inductive proximity switches are used to monitor the current position of automation components. They are available from SCHUNK in the versions IN (sensor with 30 cm molded cable and cable connector) or INK (sensor with 2 m long feeder cable and litz wires for wiring).



Function description

With their oscillator coil, inductive proximity switches produce a high-frequency, alternating magnetic field. This field occurs on the active surface of the sensor. If a metal object enters the field, it draws energy from the magnetic field, thereby reducing the oscillation amplitude. This change is detected, and the sensor switches.

Your advantages and benefits

Mounting through bracket

for simple, fast assembly

Version with LED display

for checking the switching state directly at the sensor

Version with connector

for easy, rapid replacement of the extension cable

Ultra-flexible PUR cable

for a long life and resistance to many chemicals

Proximity switch can be installed flush

for minimal interfering contours in the application

Application example

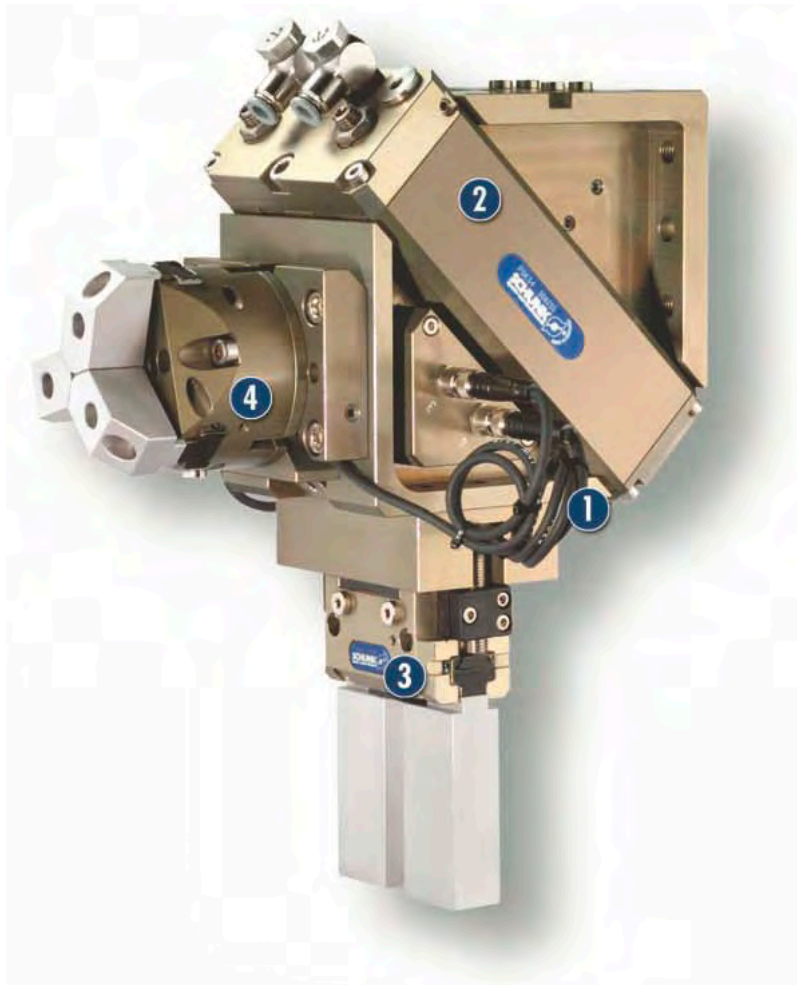

Area of application

For monitoring of gripping and rotary modules, linear modules and robot accessories. Inductive SCHUNK sensors detect metals without contact and are resistant to vibration, dust and humidity.

- 1** Plug-in IN Sensors

2 PSK Swivel Head
- 3** PGN 2-Finger Parallel Gripper with ABR finger blanks

4 PZN 3-Finger Centric Gripper with workpiece-specific gripper fingers

General information

Protection class according to DIN 40050

IP 67 in connected condition for use in clean or dusty environments or in the event of contact with water. Contact with other media (cooling lubricants, acidic or caustic substances, etc.) frequently does not impair the function, but this cannot be guaranteed by SCHUNK.

Voltage

10 - 30 V DC, residual ripple < 15 %

Switching method

PNP switching

Warranty

24 months

Notes

SCHUNK gripping, rotary and linear modules and robot accessory components must always be ordered from SCHUNK with the matching sensors, as these are ideally adapted to work together.

If major characteristics such as switching distance, switching function, hysteresis and voltage are largely the same, then proximity switches from other manufacturers may be used instead of inductive proximity switches (IN, INK) from SCHUNK.

However, if proximity switches from other manufacturers are used, SCHUNK cannot guarantee either their function or their functional reliability.



Circuit diagram of closer

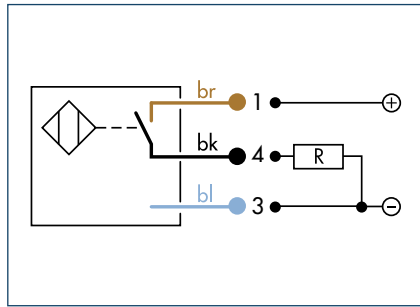

Circuit diagram of opener

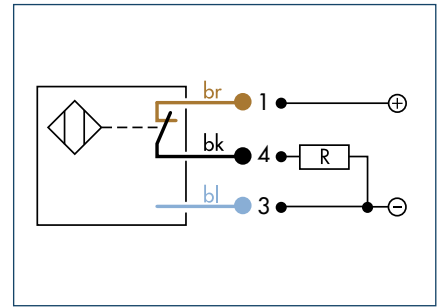

Technical data

Description		IN 40-S-M8	IN 40-S-M12	INK 40-S	IN 40-O-M8	IN 40-O-M12	INK 40-O	IN 40-S-M5-PNP	IN 40-S-M5-NPN
	ID	0301474	0301574	0301555	0301484	0301584	0301556	0301491	0301492
Switching function		Closer	Closer	Closer	Opener	Opener	Opener	Closer	Closer
Switching distance	[mm]	0.8	0.8	0.8	0.8	0.8	0.8	0.8	0.8
Hysteresis of nominal switching distance		< 15%	< 15%	< 15%	< 15%	< 15%	< 15%	< 15%	< 15%
Switching method		PNP	PNP	PNP	PNP	PNP	PNP	PNP	NPN
Cable length	[cm]	30.0	30.0	200.0	30.0	30.0	200.0	30.0	30.0
Cable connector/cable end		M8	M12	Open wire	M8	M12	Open wire	M8	M8
Type of voltage		DC	DC	DC	DC	DC	DC	DC	DC
Nominal voltage	[V]	24.0	24.0	24.0	24.0	24.0	24.0	24.0	24.0
Min. voltage	[V]	10.0	10.0	10.0	10.0	10.0	10.0	10.0	10.0
Max. voltage	[V]	30.0	30.0	30.0	30.0	30.0	30.0	30.0	30.0
Voltage drop	[V]	1.5	1.5	1.5	1.5	1.5	1.5	1.5	1.5
Max. power on contact	[A]	0.2	0.2	0.2	0.2	0.2	0.2	0.2	0.2
Min. ambient temperature	[°C]	-25.0	-25.0	-25.0	-25.0	-25.0	-25.0	-25.0	-25.0
Max. ambient temperature	[°C]	70.0	70.0	70.0	70.0	70.0	70.0	70.0	70.0
Max. switching frequency	[Hz]	1000.0	1000.0	1000.0	1000.0	1000.0	1000.0	1000.0	1000.0
IP class (sensor)		67	67	67	67	67	67	67	67
IP class (connector, plugged in)		67	67	67	67	67	67	67	67
LED display on sensor		Yes	Yes	Yes	Yes	Yes	Yes	Yes	Yes
Cable diameter	[mm]	3.5	3.5	3.5	3.5	3.5	3.5	3.5	3.5
Min. bending radius (dynamic)	[mm]	35.0	35.0	35.0	35.0	35.0	35.0	35.0	35.0
Min. bending radius (static)	[mm]	17.5	17.5	17.5	17.5	17.5	17.5	17.5	17.5
No. of wires		3	3	3	3	3	3	3	3
Wire cross section	[mm ²]	0.14	0.14	0.14	0.14	0.14	0.14	0.14	0.14

IN 40 sensor

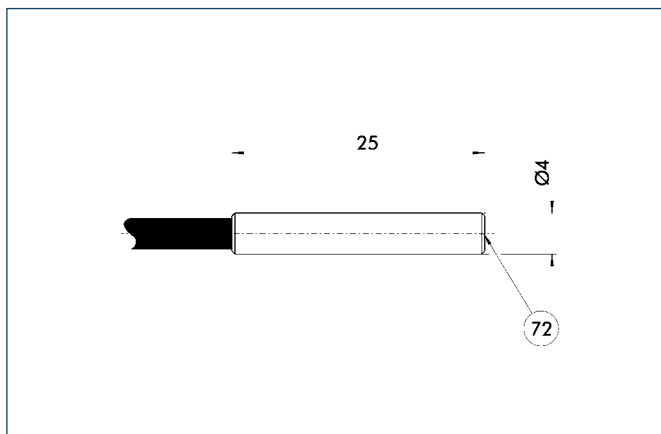

72 Active sensor surface

M8 connector

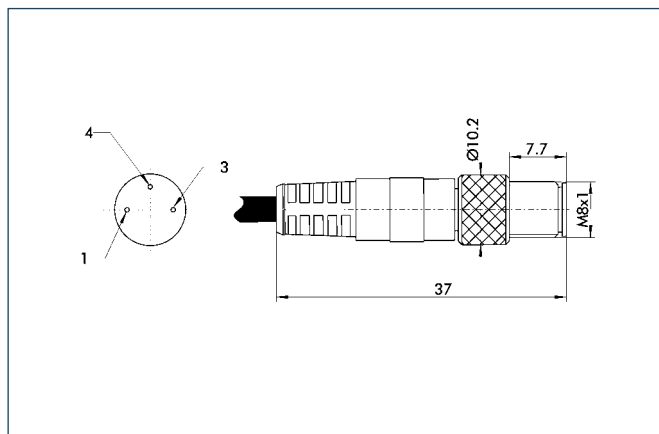

M12 connector

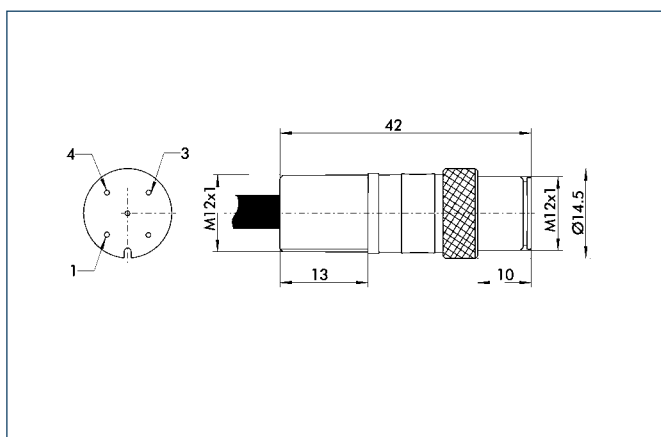

Circuit diagram of closer

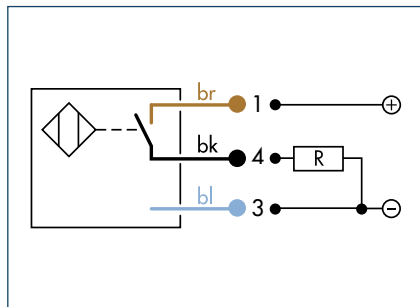

Technical data

Description	IN 60-SM8		IN 60-SM12	
	ID	0301485	0301585	0301553
Switching function		Closer	Closer	Closer
Switching distance	[mm]	1.5	1.5	1.5
Hysteresis of nominal switching distance		< 15%	< 15%	< 15%
Switching method		PNP	PNP	PNP
Cable length	[cm]	30.0	30.0	200.0
Cable connector/cable end		M8	M12	Open wire
Type of voltage		DC	DC	DC
Nominal voltage	[V]	24.0	24.0	24.0
Min. voltage	[V]	10.0	10.0	10.0
Max. voltage	[V]	30.0	30.0	30.0
Voltage drop	[V]	1.5	1.5	1.5
Max. power on contact	[A]	0.2	0.2	0.2
Min. ambient temperature	[°C]	-25.0	-25.0	-25.0
Max. ambient temperature	[°C]	70.0	70.0	70.0
Max. switching frequency	[Hz]	1000.0	1000.0	1000.0
IP class (sensor)		67	67	67
IP class (connector, plugged in)		67	67	67
LED display on sensor		No	No	No
Cable diameter	[mm]	3.5	3.5	3.5
Min. bending radius (dynamic)	[mm]	35.0	35.0	35.0
Min. bending radius (static)	[mm]	17.5	17.5	17.5
No. of wires		3	3	3
Wire cross section	[mm ²]	0.14	0.14	0.14

IN 60/S sensor

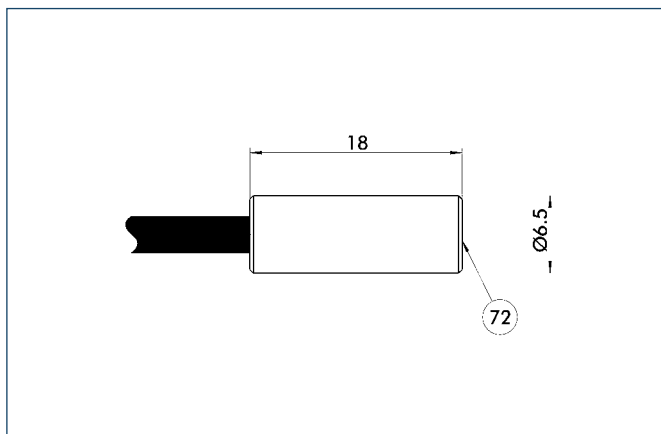

72 Active sensor surface

M8 connector

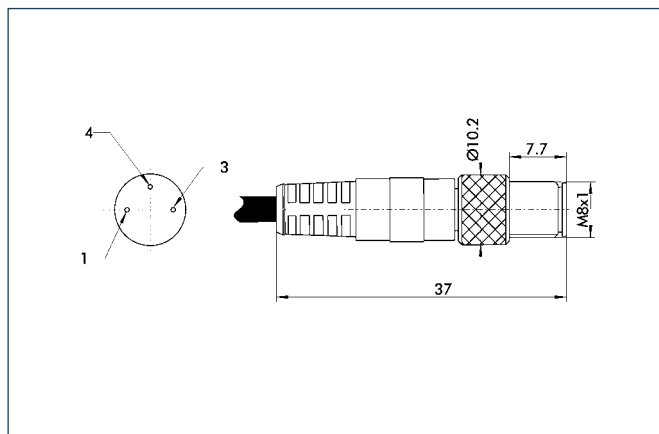

M12 connector

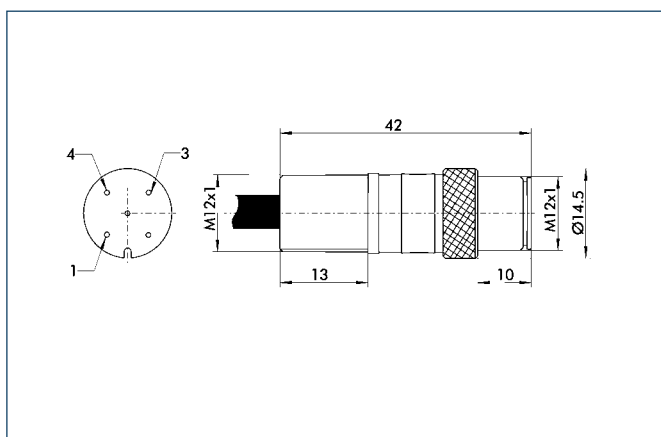

Circuit diagram of closer

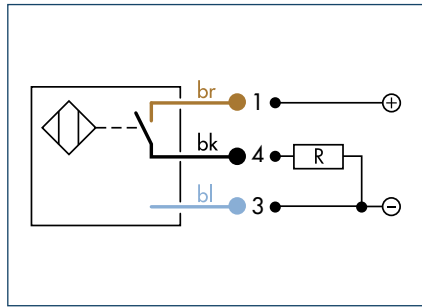

Technical data

Description		IN 65-SM8	IN 65-SM12	INK 65-S
	ID	0301476	0301576	0301554
Switching function		Closer	Closer	Closer
Switching distance	[mm]	1.5	1.5	1.5
Hysteresis of nominal switching distance		< 15%	< 15%	< 15%
Switching method		PNP	PNP	PNP
Cable length	[cm]	30.0	30.0	200.0
Cable connector/cable end		M8	M12	Open wire
Type of voltage		DC	DC	DC
Nominal voltage	[V]	24.0	24.0	24.0
Min. voltage	[V]	10.0	10.0	10.0
Max. voltage	[V]	30.0	30.0	30.0
Voltage drop	[V]	1.5	1.5	1.5
Max. power on contact	[A]	0.2	0.2	0.2
Min. ambient temperature	[°C]	-25.0	-25.0	-25.0
Max. ambient temperature	[°C]	70.0	70.0	70.0
Max. switching frequency	[Hz]	1000.0	1000.0	1000.0
IP class (sensor)		67	67	67
IP class (connector, plugged in)		67	67	67
LED display on sensor		Yes	Yes	No
Cable diameter	[mm]	3.5	3.5	3.5
Min. bending radius (dynamic)	[mm]	35.0	35.0	35.0
Min. bending radius (static)	[mm]	17.5	17.5	17.5
No. of wires		3	3	3
Wire cross section	[mm ²]	0.14	0.14	0.14

IN 65/S sensor

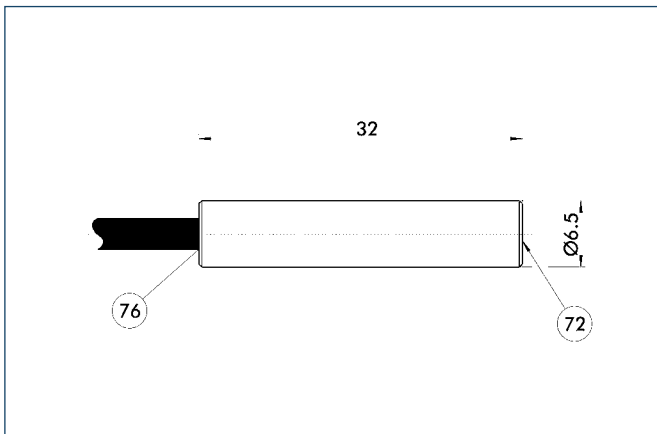

- 72 Active sensor surface
- 76 LED

M8 connector

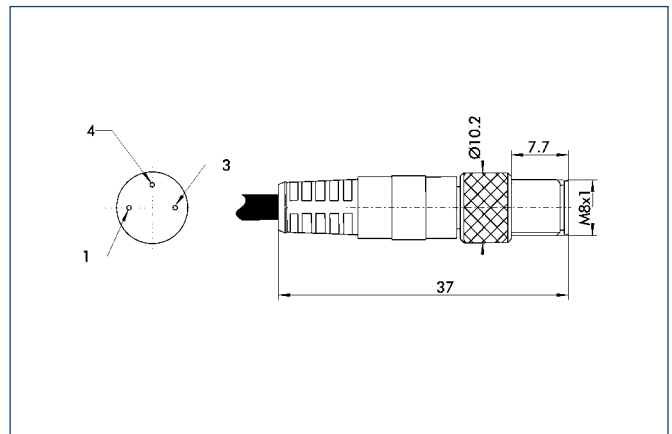

M12 connector

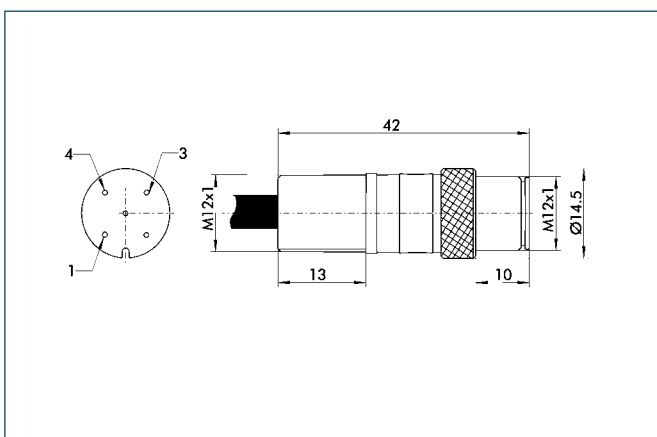



Circuit diagram of closer

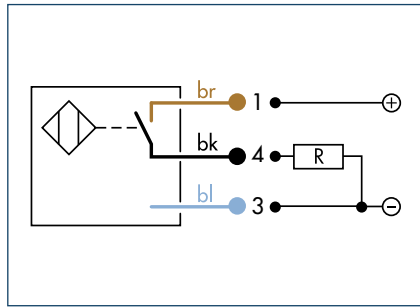

Circuit diagram of opener

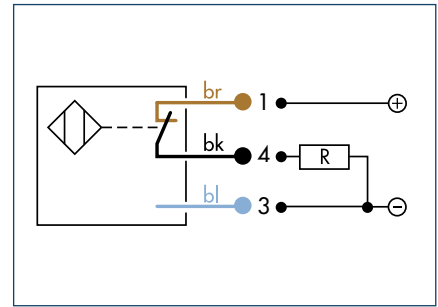

Technical data

Description		IN 80-SM8	IN 80-SM12	INK 80-S	IN 80-O-M8	IN 80-O-M12	INK 80-O
	ID	0301478	0301578	0301550	0301488	0301588	0301551
Switching function		Closer	Closer	Closer	Opener	Opener	Opener
Switching distance	[mm]	1.5	1.5	1.5	1.5	1.5	1.5
Hysteresis of nominal switching distance		< 15%	< 15%	< 15%	< 15%	< 15%	< 15%
Switching method		PNP	PNP	PNP	PNP	PNP	PNP
Cable length	[cm]	30.0	30.0	200.0	30.0	30.0	200.0
Cable connector/cable end		M8	M12	Open wire	M8	M12	Open wire
Type of voltage		DC	DC	DC	DC	DC	DC
Nominal voltage	[V]	24.0	24.0	24.0	24.0	24.0	24.0
Min. voltage	[V]	10.0	10.0	10.0	10.0	10.0	10.0
Max. voltage	[V]	30.0	30.0	30.0	30.0	30.0	30.0
Voltage drop	[V]	1.5	1.5	1.5	1.5	1.5	1.5
Max. power on contact	[A]	0.2	0.2	0.2	0.2	0.2	0.2
Min. ambient temperature	[°C]	-25.0	-25.0	-25.0	-25.0	-25.0	-25.0
Max. ambient temperature	[°C]	70.0	70.0	70.0	70.0	70.0	70.0
Max. switching frequency	[Hz]	1000.0	1000.0	1000.0	1000.0	1000.0	1000.0
IP class (sensor)		67	67	67	67	67	67
IP class (connector, plugged in)		67	67	67	67	67	67
LED display on sensor		Yes	Yes	Yes	Yes	Yes	Yes
Cable diameter	[mm]	3.5	3.5	3.5	3.5	3.5	3.5
Min. bending radius (dynamic)	[mm]	35.0	35.0	35.0	35.0	35.0	35.0
Min. bending radius (static)	[mm]	17.5	17.5	17.5	17.5	17.5	17.5
No. of wires		3	3	3	3	3	3
Wire cross section	[mm ²]	0.14	0.14	0.14	0.14	0.14	0.14

IN 80 sensor

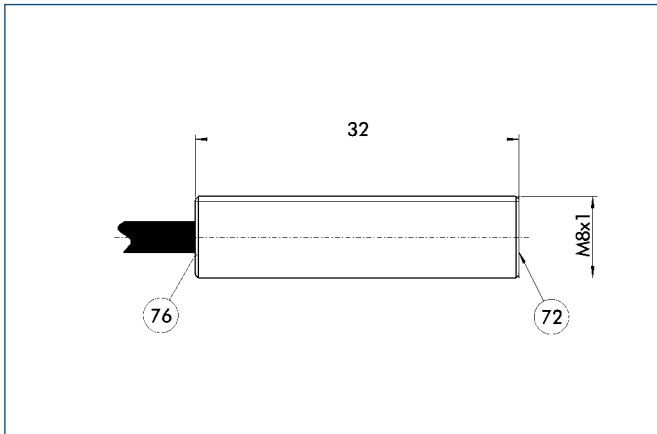

- 72 Active sensor surface
- 76 LED

M8 connector

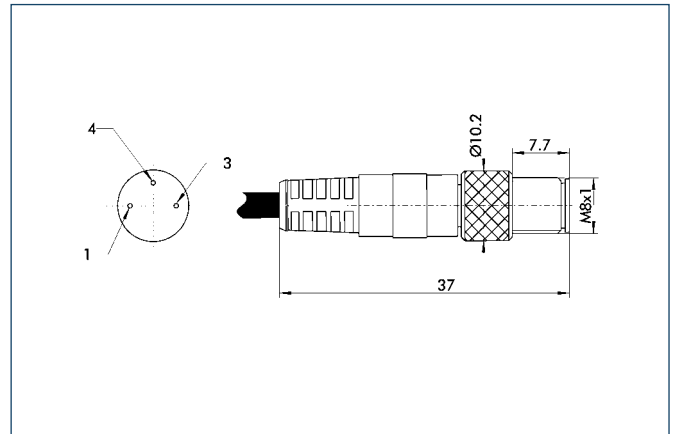

M12 connector

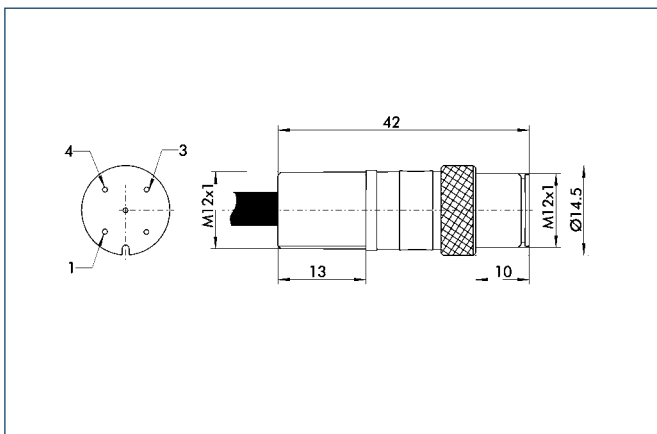

Circuit diagram of closer

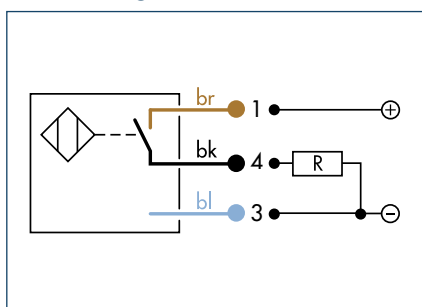

Technical data

Description		IN 80-SL-M12	INK 80-SL
	ID	0301529	0301579
Switching function		Closer	Closer
Switching distance	[mm]	3.0	3.0
Hysteresis of nominal switching distance		< 15%	< 15%
Switching method		PNP	PNP
Cable length	[cm]	30.0	200.0
Cable connector/cable end		M12	Open wire
Type of voltage		DC	DC
Nominal voltage	[V]	24.0	24.0
Min. voltage	[V]	10.0	10.0
Max. voltage	[V]	30.0	30.0
Voltage drop	[V]	1.5	1.5
Max. power on contact	[A]	0.2	0.2
Min. ambient temperature	[°C]	-25.0	-25.0
Max. ambient temperature	[°C]	70.0	70.0
Max. switching frequency	[Hz]	1000.0	1000.0
IP class (sensor)		67	67
IP class (connector, plugged in)		67	67
LED display on sensor		Yes	Yes
Cable diameter	[mm]	3.5	3.5
Min. bending radius (dynamic)	[mm]	35.0	35.0
Min. bending radius (static)	[mm]	17.5	17.5
No. of wires/contacts		3	3
Wire cross section	[mm ²]	0.14	0.14

IN B-80 sensor

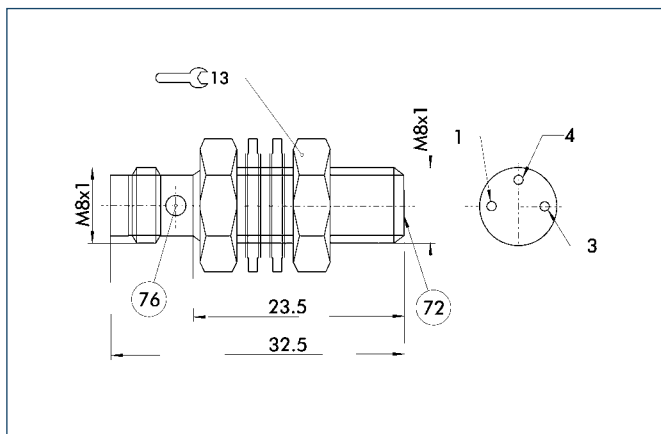

- 72 Active sensor surface
- 76 LED

IN 80/SL sensor

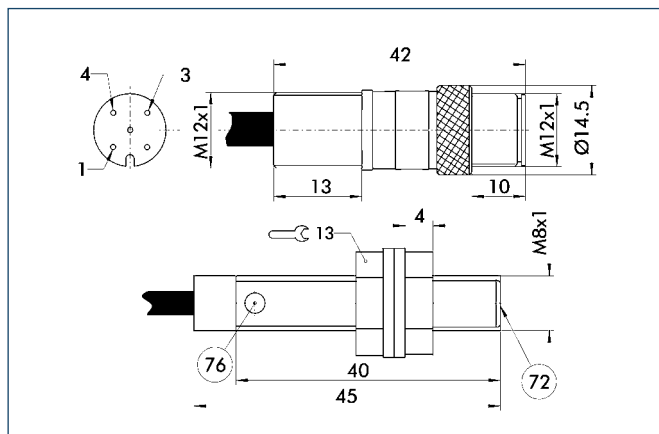

- 72 Active sensor surface
- 76 LED

Magnetic Switches

Magnetic switches are used for monitoring the position of automation components. They detect the approach of a magnet without contact and, above a certain switching threshold, enable their output.



Function description

Magnetic switches react to magnetic fields. The resistors in the sensor consist of several ferromagnetic and non-magnetic layers. Two shielded and two non-shielded resistors are combined in a bridge circuit, which produces a signal proportional to the magnetic field when one is present. Above a threshold value, an output signal is switched via a comparator, and the sensor reacts.

Your advantages and benefits

Installation in the sensor slot

for space-saving, simple and fast assembly

Version with LED display (MMS 22)

for checking the switching position directly at the sensor

Version with connector

for easy, rapid replacement of the extension cable

Ultra-flexible PUR cable

for a long life and resistance to many chemicals

Application example

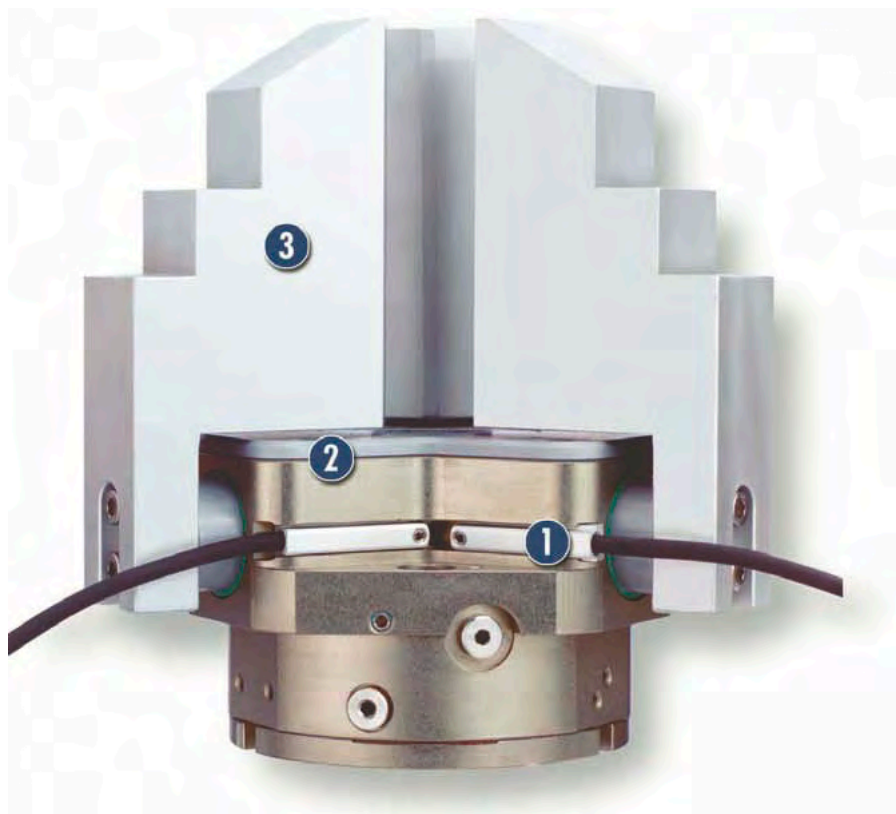

1 MMS Electronic Magnetic Switches for mounting in the C-slot of the gripper

2 Sealed 3-Finger Centric Gripper

3 Workpiece-specific Gripper Fingers

General information

Material

Sensor housing: PA in the MMS 22, aluminum in the MMS 30
Cable: with PUR sheath

Fastening

Clamps in the sensor slot

Protection class according to DIN 40050

IP 67 in connected condition for use in clean or dusty environments or in the event of contact with water. Contact with other media (cooling lubricants, acidic or caustic substances, etc.) frequently does not impair the function, but this cannot be guaranteed by SCHUNK.

Voltage

10 - 30 V DC at < 10 % residual ripple

Switching method

PNP switching / NPN switching

Warranty

24 months

Area of application

For use in the monitoring of gripping and rotary modules, linear modules and robot accessories. Magnetic switches from SCHUNK detect metals without contact or wear and are resistant to vibration, dust and humidity. Magnetic switches are fitted in slots and therefore do not form any additional interfering contours.

Notes

SCHUNK gripper, rotary and linear modules and robot accessory components that are to be monitored with electromagnetic slot-fitted switches can generally only be reliably monitored with the appropriate electromagnetic switches from SCHUNK.

Sensors and products are matched on the basis of the relationships between the parameters type and field strength of the magnet, distance, wall thickness and wall material of the magnet and the sensor, and the orientation and sensitivity of the sensor itself.

For this reason, sensors from other manufacturers employed in SCHUNK products rarely give satisfactory switching results.



Circuit diagram of closer

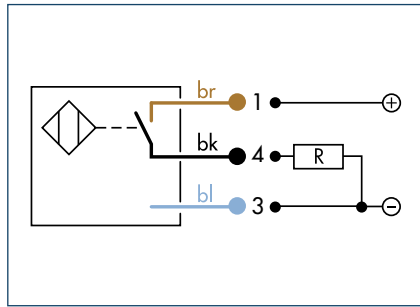

Circuit diagram of NPN closer

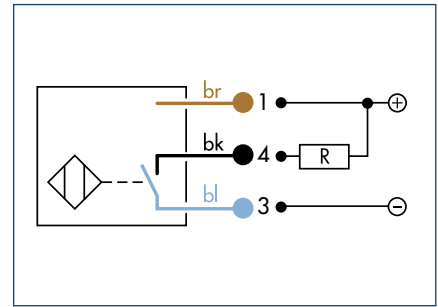

Technical data

Description	MMS 22-S-M5-PNP		MMS 22-S-M5-NPN		MMS 22-S-M8-PNP		MMS 22-S-M8-NPN		MMSK 22-S-PNP		MMSK 22-S-NPN	
	ID	0301438	0301439	0301432	0301433	0301434	0301435					
Switching function		Closer	Closer	Closer	Closer	Closer	Closer					
Switching method		PNP	NPN	PNP	NPN	PNP	NPN					
Cable length	[cm]	30.0	30.0	30.0	30.0	200.0	200.0					
Cable connector/cable end		M5	M5	M8	M8	Open wire	Open wire					
Type of voltage		DC	DC	DC	DC	DC	DC					
Nominal voltage	[V]	24.0	24.0	24.0	24.0	24.0	24.0					
Min. voltage	[V]	10.0	10.0	10.0	10.0	10.0	10.0					
Max. voltage	[V]	30.0	30.0	30.0	30.0	30.0	30.0					
Voltage drop	[V]	1.5	1.5	1.5	1.5	1.5	1.5					
Max. power on contact	[A]	0.2	0.2	0.2	0.2	0.2	0.2					
Min. ambient temperature	[°C]	-10.0	-10.0	-10.0	-10.0	-10.0	-10.0					
Max. ambient temperature	[°C]	70.0	70.0	70.0	70.0	70.0	70.0					
Typical switching time	[s]	0.001	0.001	0.001	0.001	0.001	0.001					
IP class (sensor)		67	67	67	67	67	67					
IP class (connector, plugged in)		67	67	67	67	67	67					
LED display on sensor		Yes	Yes	Yes	Yes	Yes	Yes					
Cable diameter	[mm]	2.1	2.1	2.1	2.1	2.1	2.1					
Min. bending radius (dynamic)	[mm]	21.0	21.0	21.0	21.0	21.0	21.0					
Min. bending radius (static)	[mm]	10.5	10.5	10.5	10.5	10.5	10.5					
No. of wires		3	3	3	3	3	3					
Wire cross section	[mm ²]	0.14	0.14	0.14	0.14	0.14	0.14					

MMS 22 sensor

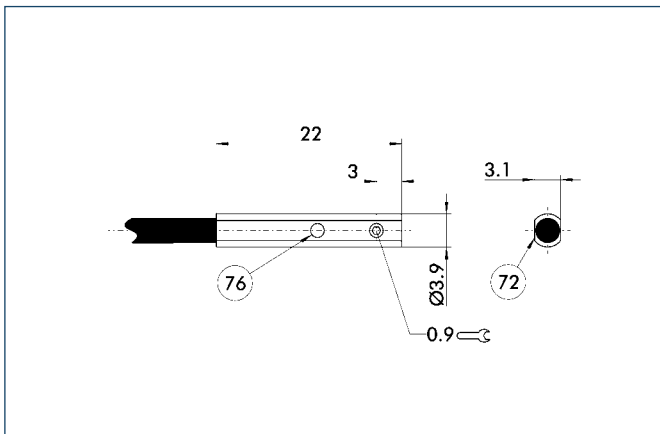

- 72 Active sensor surface
- 76 LED

M5 connector

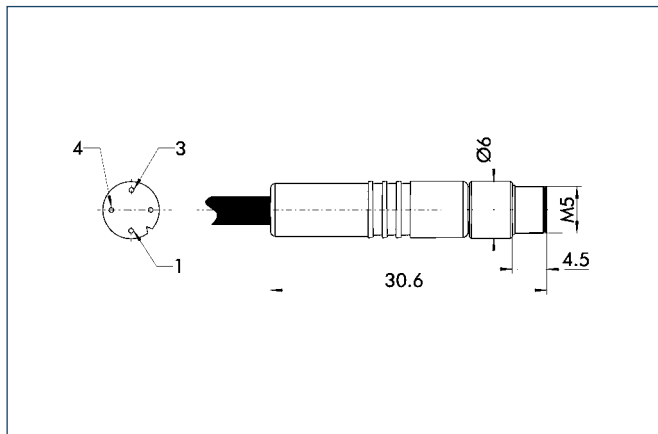

M8 connector

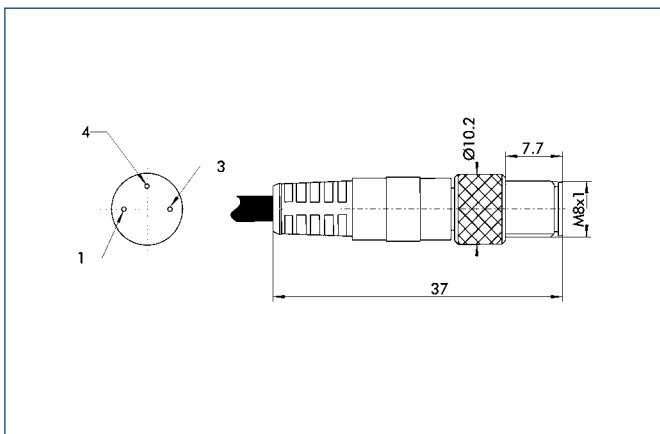



Circuit diagram of closer

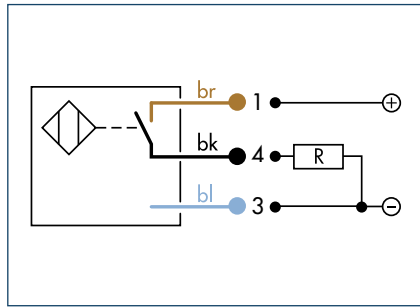

Circuit diagram of NPN closer

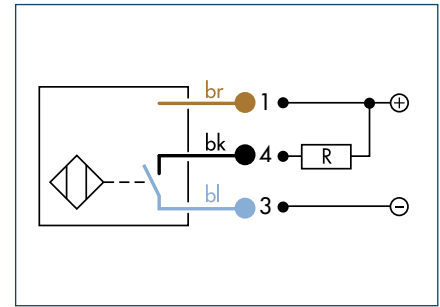

Technical data

Description	MMS 22-S-M5-PNP-SA	MMS 22-S-M5-NPN-SA	MMS 22-S-M8-PNP-SA	MMS 22-S-M8-NPN-SA	MMSK 22-S-PNP-SA	MMSK 22-S-NPN-SA	
	ID	0301448	0301449	0301442	0301443	0301444	0301445
Switching function	Closer	Closer	Closer	Closer	Closer	Closer	
Switching method	PNP	NPN	PNP	NPN	PNP	NPN	
Cable length	[cm]	30.0	30.0	30.0	30.0	200.0	200.0
Cable connector/cable end	M5	M5	M8	M8	Open wire	Open wire	
Type of voltage	DC	DC	DC	DC	DC	DC	
Nominal voltage	[V]	24.0	24.0	24.0	24.0	24.0	24.0
Min. voltage	[V]	10.0	10.0	10.0	10.0	10.0	10.0
Max. voltage	[V]	30.0	30.0	30.0	30.0	30.0	30.0
Voltage drop	[V]	1.5	1.5	1.5	1.5	1.5	1.5
Max. power on contact	[A]	0.2	0.2	0.2	0.2	0.2	0.2
Min. ambient temperature	[°C]	-10.0	-10.0	-10.0	-10.0	-10.0	-10.0
Max. ambient temperature	[°C]	70.0	70.0	70.0	70.0	70.0	70.0
Typical switching time	[s]	0.001	0.001	0.001	0.001	0.001	0.001
IP class (sensor)	67	67	67	67	67	67	
IP class (connector, plugged in)	67	67	67	67	67	67	
LED display on sensor	Yes	Yes	Yes	Yes	Yes	Yes	
Cable diameter	[mm]	2.1	2.1	2.1	2.1	2.1	2.1
Min. bending radius (dynamic)	[mm]	21.0	21.0	21.0	21.0	21.0	21.0
Min. bending radius (static)	[mm]	10.5	10.5	10.5	10.5	10.5	10.5
No. of wires		3	3	3	3	3	3
Wire cross section	[mm ²]	0.14	0.14	0.14	0.14	0.14	0.14

MMS 22-SA sensor

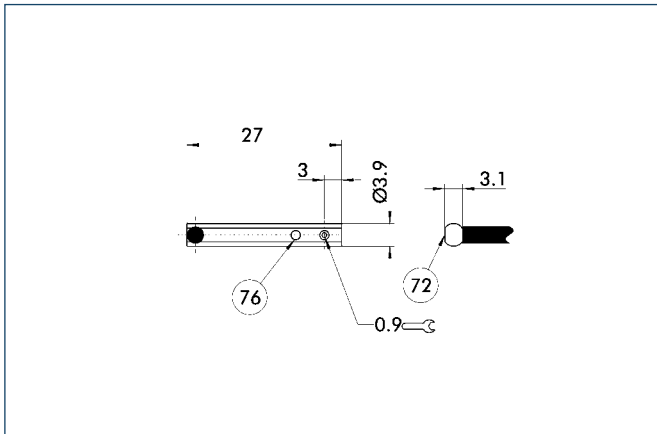

- 72 Active sensor surface
- 76 LED

M5 connector

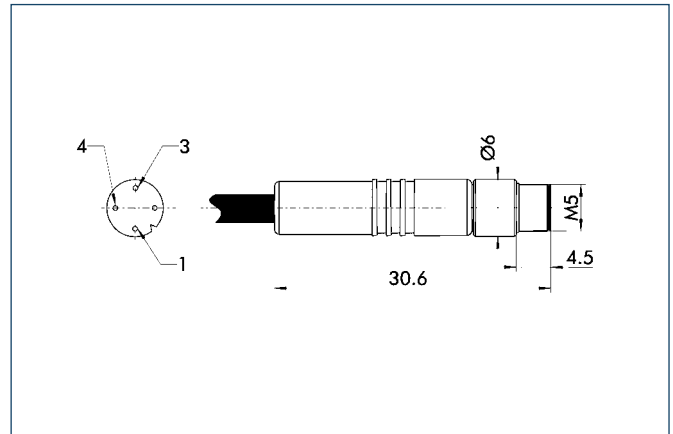

M8 connector

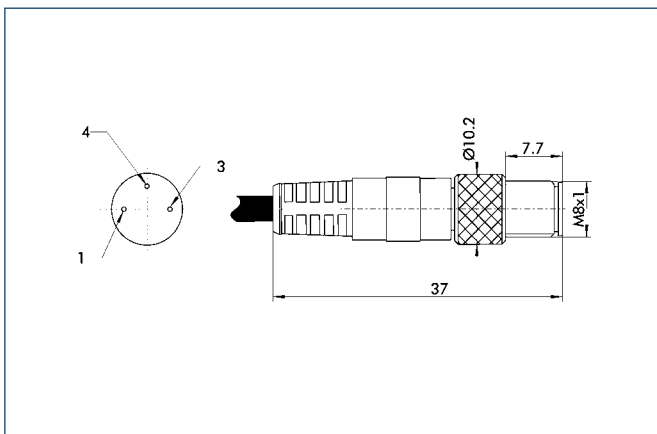

Sensor Tester

The SST sensor tester enables the rapid testing and adjustment of inductive sensors, magnetic switches and reed contacts. The necessary power is supplied by a 9 V compound battery.



Function description

The sensor is connected to the M8 – M12 or terminal connection of the sensor tester and the ON button pressed. The sensor position is displayed visually by LEDs and output acoustically via a signal buzzer.

Your advantages and benefits

Visual and acoustic signal

for simple function checking and adjustment

For 2- and 3-wire DC technology

enabling the connection of reed contacts, capacitive and inductive sensors

Tests possible without dismantling sensors

for short maintenance times

Connections for M8 and M12 or open cable ends possible

ensuring suitability for all SCHUNK sensors

PNP and NPN sensors can be tested

Operating voltage with 9 V compound battery

for mobile use

Automatic cut-off function

for an extended battery life

Application example



Area of application

Sensor testing and adjustment of the switching point (sensor calibration)

1 Sensor tester SST

3 Metal plate

2 Inductive proximity switches IN 80

General information

Scope of delivery

Sensor tester incl. assembly and operating manual with manufacturer's declaration, 9 V compound battery

Notes

Please note that only one SST input (M8 or M12 or cable terminal input) can be used at once.

If the toggle switch is towards the sticker (nameplate), PNP is selected, if not, NPN.



Technical data

Description	ID	SST
Battery		9 V DC (compound battery Type LR 61)
Connection 1		M12*1
Connection 2		M8*1
Connection 3		direct clamping
Housing material		plastic
IP class		20

Main views

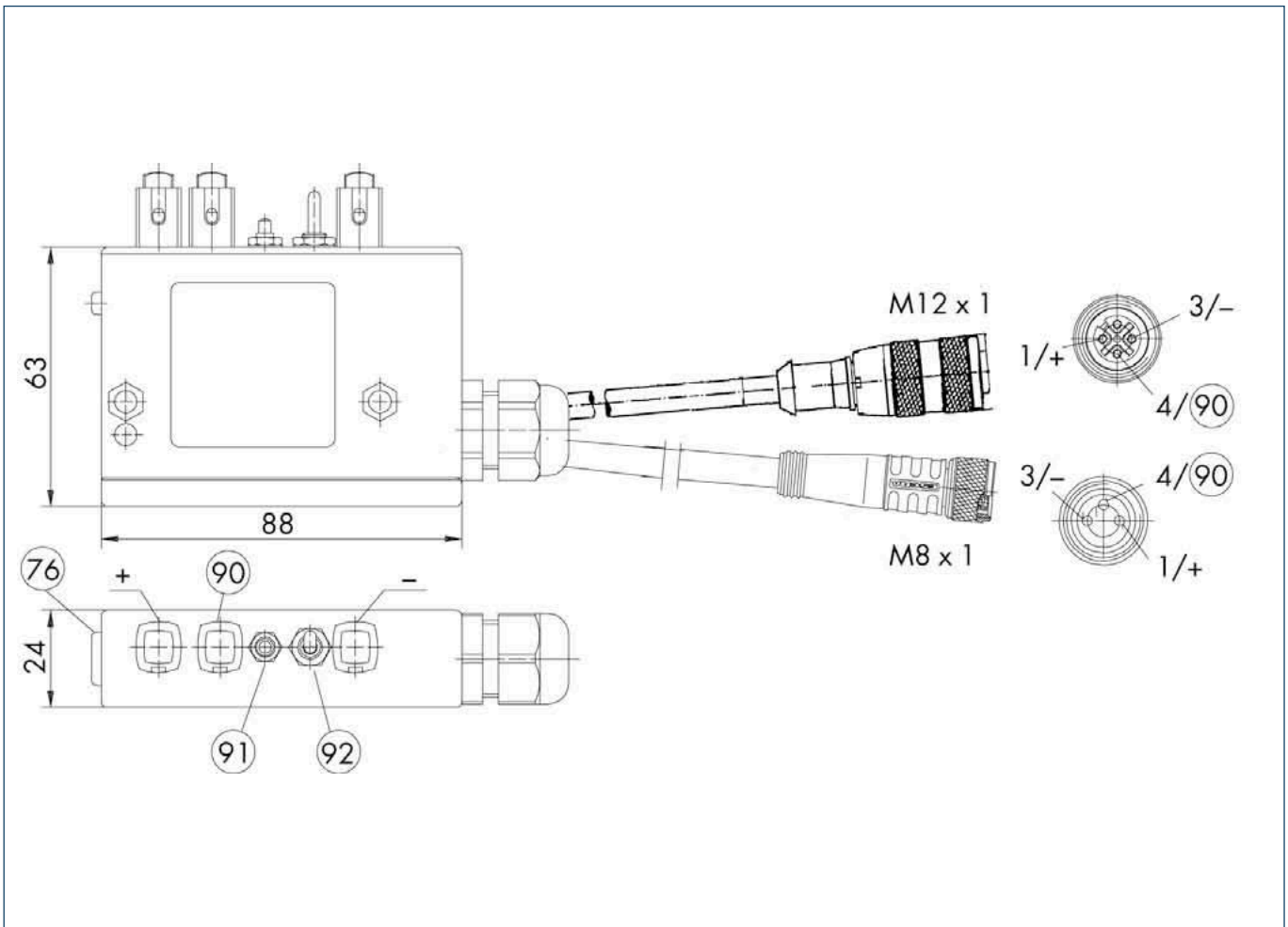

- ⑦⑥ LED
- ⑨⑩ Output
- ⑨① ON button
- ⑨② PNP/NPN changeover switch



Pressure Maintenance Valves and Fittings

for connection and mounting of pneumatic hoses



Your advantages and benefits

Suitable

for all SCHUNK gripper, rotary and linear modules, in addition to robot accessories

Flexible utilization

for use on pneumatic hoses from various manufacturers

Fittings as plug-in connections

for fast hose attachment

SDV-P pressure maintenance valve

prevents loss of pressure

Application example

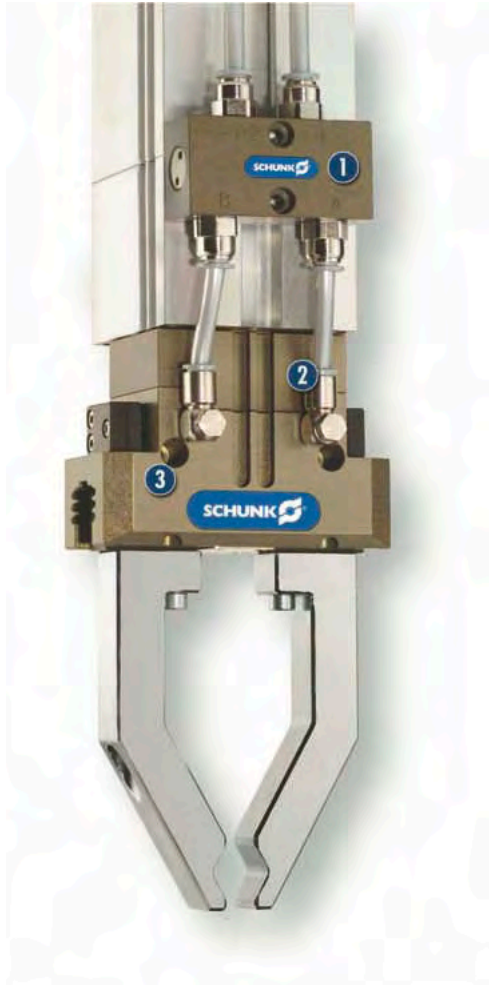

Area of application

for secure hose connections in automation solutions

1 SDV-P Pressure Maintenance Valve

2 SWV Banjo Fitting

3 PGN-plus 2-Finger Parallel Gripper
with workpiece-specific gripper
fingers

General information

Warranty
24 months

WV elbow fitting

Version as plug-in connection for fast and easy connection to the pneumatic energy supplies



Technical data

Description		WV-G1/8-6	WV-G1/8-8	WV-G1/4-6
	ID	9937129	9936730	9937170
For hose diameter	[mm]	6.0	8.0	6.0
Threaded connection	["]	G1/8	G1/8	G1/4
Max. pressure	[bar]	20.0	20.0	20.0
Min. ambient temperature	[°C]	-10.0	-10.0	-10.0
Max. ambient temperature	[°C]	60.0	60.0	60.0

Main view WV

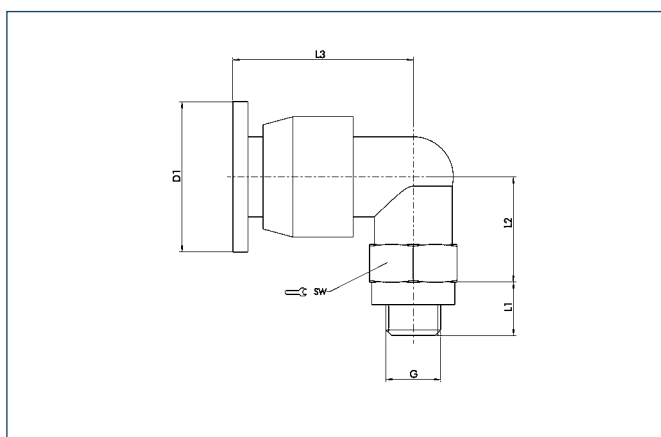

Variable	WVG 1-8-6	WVG 1-8-8	WVG 1-4-6
G	1/8"	1/8"	1/4"
L ₁	5	5	7
L ₂	13.5	16	15.5
L ₃	22	25.5	23.5
D ₁	12	14	12
SW	13	13	17



SWV banjo fitting

Version as plug-in connection for fast and easy connection to the pneumatic energy supplies



Technical data

Description		SWV-M3-4	SWV-M5-6	SWV-G4-6	SWV-G8-6	SWV-G4-8
	ID	9210505	9936171	9937128	9937152	9936728
For hose diameter	[mm]	4.0	6.0	6.0	6.0	8.0
Threaded connection	["]	M 3	M 5	G1/4	G1/8	G1/4
Max. pressure	[bar]	20.0	20.0	20.0	20.0	20.0
Min. ambient temperature	[°C]	-10.0	-10.0	-10.0	-10.0	-10.0
Max. ambient temperature	[°C]	60.0	60.0	60.0	60.0	60.0

Main view SWV

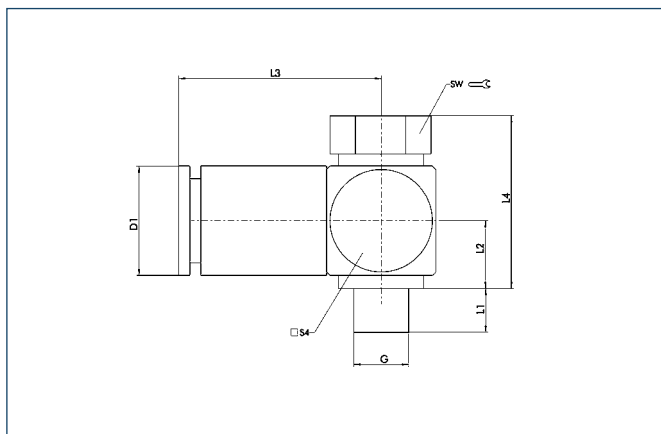

Variable	SWV-M5-6	SWV-G8-6	SWV-G4-6	SWV-G4-8
G	M5	G1/8"	G1/4"	G1/4"
L ₁	4	6.5	8	8
L ₂	6.2	8.25	8.4	15.3
L ₃	18.5	22.5	24.5	25
L ₄	15.8	20.5	21.6	21.6
D ₁	10	12	12	13.5
SW	8	14	17	17
S4	10	15	19	19

Main view SWV-M3

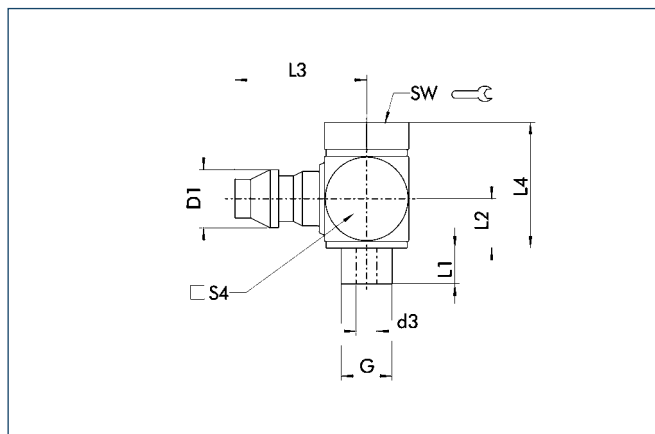

Variable	SWV-M3-4
G	M3
d ₃	1.1
L ₁	2
L ₂	2.5
L ₃	7.3
L ₄	7.3
D ₁	3.4
SW	5
S4	5

DSV banjo fitting with one-way flow control valve

Version as plug-in connection for fast and easy connection to the pneumatic energy supplies



Technical data

Description		DSV-M3-4	DSV-M5-6	DSV-G8-6	DSV-G4-6	DSV-G4-8
	ID	9720005	9936160	9936159	9936161	9936162
Hose	[mm]	3.0	6.0	6.0	6.0	8.0
Min. operating temperature	[°C]	-10.0	-10.0	-10.0	-10.0	-10.0
Max. operating temperature	[°C]	60.0	60.0	60.0	60.0	60.0
Max. operating pressure	[bar]	20.0	20.0	20.0	20.0	20.0

Main view DSV

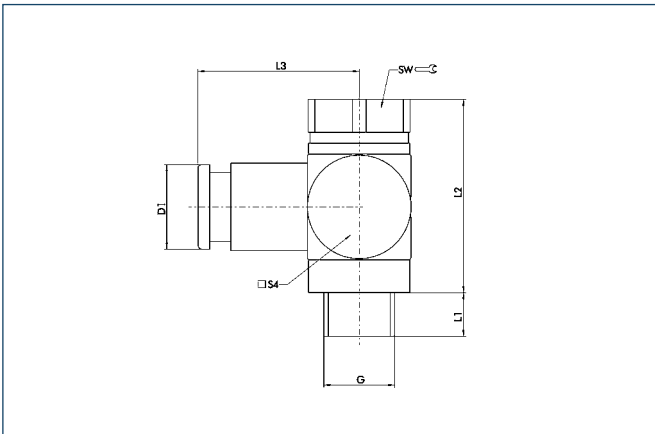

Variable	DSV-M3-4	DSV-M5-6	DSV-G8-6	DSV-G4-6	DSV-G8-8
G	M3	M5	G1/8"	G1/4"	G1/8"
L ₁	2.5	4	5	6.5	5
L _{2 max.}	29	21.5	30	32	30
L ₃	11	21	22.5	24.5	23
D ₁	4.8	10.4	12	12	14
SW	knurl	8	14	17	14



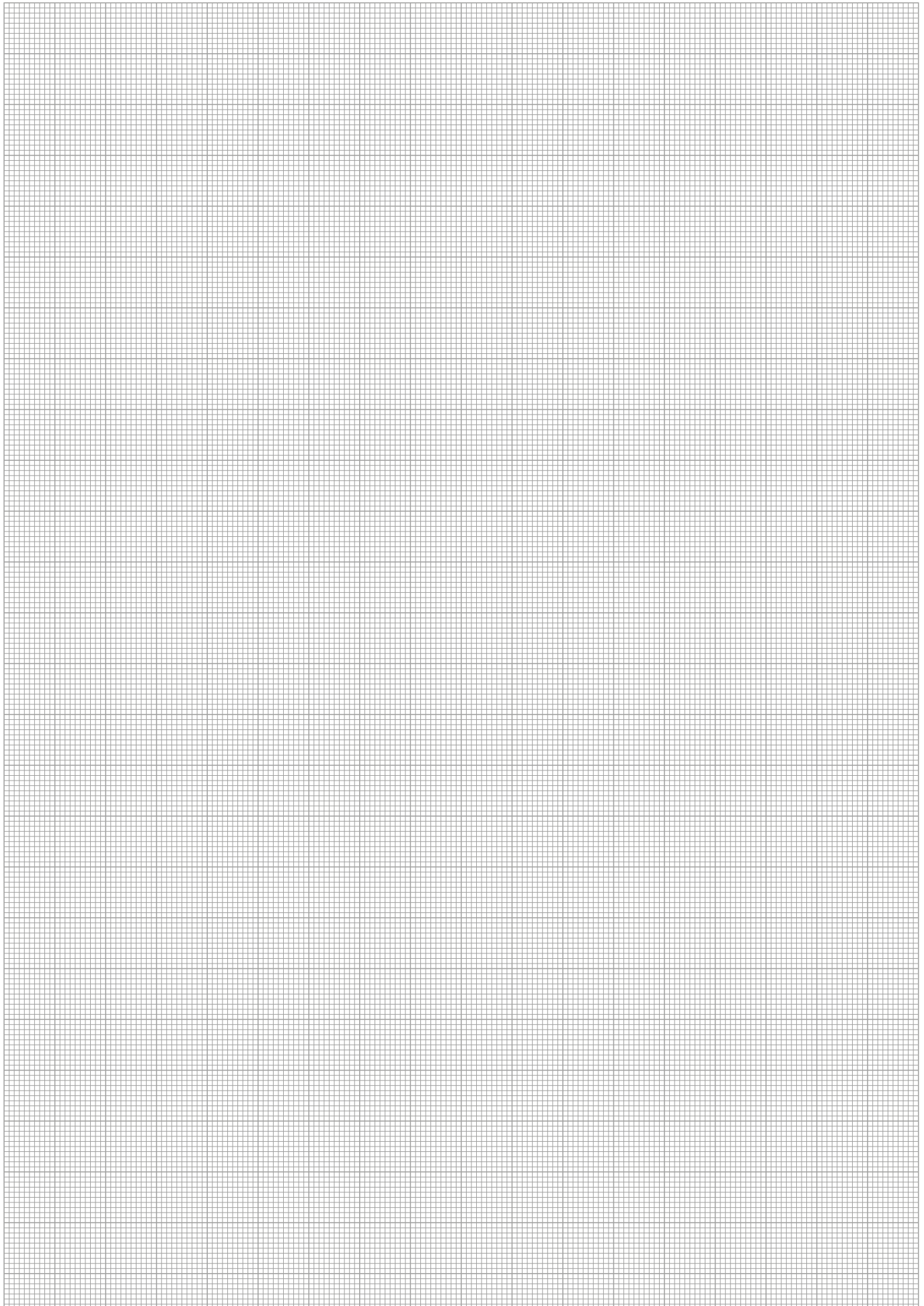

SCHUNK Service

We can provide you with professional, reliable and comprehensive support. For you, SCHUNK Service means being on the safe side of efficiency. For us, it is an important part of our corporate philosophy. Our extensive range of service - from initial advice to after sales service - convinces with absolute reliability and technical knowledge.

Individual service - for better results

- Hotline to our inside technical consultants weekdays from 7 a.m. to 6 p.m.
- Project-orientated, on-site technical advice at your location by our competent external consultants
- Extensive stock of standard products with lightning fast delivery service - world-wide!
- Detailed information about clamping and automation technology
- Training on innovations and SCHUNK-products - across the world in our local subsidiaries

Online service - for a fast overview

All information in digital form, clearly structured and up-to-date on our website at www.schunk.com

- List of contact persons
- Online product search based on product designations
- Product news and trends
- Data sheets
- Order forms for easy and convenient ordering
- Free download area for pages from our product catalogs and technical data, for software and calculation programs for your gripping and rotary modules
- Free 2-D/3-D CAD design models, provided in a wide range of different CAD formats - for easy integration into your design!



Subsidiaries



GERMANY
HEAD OFFICE
SCHUNK GmbH & Co. KG
Spann- und Greiftechnik
Bahnhofstr. 106-134
74348 Lauffen/Neckar
Tel. +49-7133-103-0
Fax +49-7133-103-2399
info@de.schunk.com
www.schunk.com



CHINA
SCHUNK Precision Machinery
(Hangzhou) Co., Ltd.
6, 24th Street, HEDA
Hangzhou 310018
Tel. +86-571-8672-1000
Fax +86-571-8672-8800
info@cn.schunk.com
www.cn.schunk.com

SCHUNK GmbH & Co. KG
Shanghai
Representative Office
777 Zhao Jia Bang Road
Pine City Hotel, Room 923,
Xuhui District,
Shanghai 200032
Tel. +86-21-64433177
Fax +86-21-64431922
info@cn.schunk.com
www.cn.schunk.com



GREAT BRITAIN, IRELAND
SCHUNK Intec Ltd.
Cromwell Business Centre
10 Howard Way,
Interchange Park
Newport Pagnell MK16 9QS
Tel. +44-1908-611127
Fax +44-1908-615525
info@gb.schunk.com
www.gb.schunk.com



NETHERLANDS
SCHUNK Intec B.V.
Speldenmakerstraat 3d
5232 BH 's-Hertogenbosch
Tel. +31-73-6441779
Fax +31-73-6448025
info@nl.schunk.com
www.nl.schunk.com



SPAIN
SCHUNK Intec S.L.
Foneria, 27
08304 Mataró (Barcelona)
Tel. +34-937 556 020
Fax +34-937 908 692
info@es.schunk.com
www.es.schunk.com



HUNGARY
SCHUNK Intec Kft.
Széchenyi út. 70.
3530 Miskolc
Tel. +36-46-50900-7
Fax +36-46-50900-6
info@hu.schunk.com
www.hu.schunk.com



POLAND
SCHUNK Intec Sp. z o.o.
ul. Słoneczna 116 A
Stara Iwiczna
05-500 Piaseczno
Tel. +48-22-7262500
Fax +48-22-7262525
info@pl.schunk.com
www.pl.schunk.com



SWEDEN
SCHUNK Intec AB
Morabergsvägen 28
152 42 Södertälje
Tel. +46-8 554 421 00
Fax +46-8 554 421 01
info@se.schunk.com
www.se.schunk.com



AUSTRIA
SCHUNK Intec GmbH
Holzbauernstr. 20
4050 Traun
Tel. +43-7229-65770-0
Fax +43-7229-65770-14
info@at.schunk.com
www.at.schunk.com



CZECH REPUBLIC
SCHUNK Intec s. r. o.
Ernsta Macha 1
643 00 Brno
Tel. +420-545 229 095
Fax +420-545 220 508
info@cz.schunk.com
www.cz.schunk.com



INDIA
SCHUNK India Branch Office
80 B, Yeswanthpur
Industrial Suburbs,
Bangalore 560 022
Tel. +91-80-40538999
Fax +91-80-41277363
info@in.schunk.com
www.in.schunk.com



PORTUGAL
Sales Representative
Victor Marques
Tel. +34-937-556 020
Fax +34-937-908 692
Mobil +351-963-786 445
info@pt.schunk.com
www.pt.schunk.com



SWITZERLAND, LIECHTENSTEIN
SCHUNK Intec AG
Soodring 19
8134 Adliswil 2
Tel. +41-44-7102171
Fax +41-44-7102279
info@ch.schunk.com
www.ch.schunk.com



BELGIUM, LUXEMBOURG
SCHUNK Intec N.V./S.A.
Bedrijvencentrum Regio Aalst
Industrielaan 4, Zuid III
9320 Aalst-Erembodegem
Tel. +32-53-853504
Fax +32-53-836022
info@be.schunk.com
www.be.schunk.com



DENMARK
SCHUNK Intec A/S
Storhaven 7
7100 Vejle
Tel. +45-43601339
Fax +45-43601492
info@dk.schunk.com
www.dk.schunk.com



ITALY
SCHUNK Intec S.r.l.
Via Caio Plinio 5
22072 Cermenate (CO)
Tel. +39-031-770185
Fax +39-031-771388
info@it.schunk.com
www.it.schunk.com



SLOVAKIA
SCHUNK Intec s.r.o.
Mostná 62
949 01 Nitra
Tel. +421-37-3260610
Fax +421-37-6421906
info@sk.schunk.com
www.sk.schunk.com



TURKEY
SCHUNK Intec
Bağlama Sistemleri ve
Otomasyon San. ve Tic. Ltd. Şti.
Küçükyalı İş Merkezi
Girne Mahallesi
Irmak Sokak, A Blok, No: 9
34852 Maltepe, İstanbul
Tel. +90-216-366-2111
Fax +90-216-366-2277
info@tr.schunk.com
www.tr.schunk.com



CANADA
SCHUNK Intec Corp.
190 Britannia Road East,
Units 23-24
Mississauga, ON L4Z 1W6
Tel. +1-905-712-2200
Fax +1-905-712-2210
info@ca.schunk.com
www.ca.schunk.com



FRANCE
SCHUNK Intec SARL
Parc d'Activités des Trois Noyers
15, Avenue James de Rothschild
Ferrières-en-Brie
77614 Marne-la-Vallée Cedex 3
Tel. +33-1-64 66 38 24
Fax +33-1-64 66 38 23
info@fr.schunk.com
www.fr.schunk.com



MEXICO, VENEZUELA
SCHUNK Intec S.A. de C.V.
Av. Luis Vega y Monroy # 332
Fracc. Plazas de Sol
Santiago de Querétaro,
Qro. 76099
Tel. +52-442-223-6525
Fax +52-442-223-7665
info@mx.schunk.com
www.mx.schunk.com

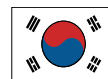

SOUTH KOREA
SCHUNK Intec Korea Ltd.
907 Joongang
Induspia 2 Bldg.,
144-5 Sangdaewon-dong,
Jungwon-gu, Seongnam-si,
Kyunggi-do, 462-722
Tel. +82-31-7376141
Fax +82-31-7376142
info@kr.schunk.com
www.kr.schunk.com



USA
SCHUNK Intec Inc.
211 Kitty Hawk Drive
Morrisville, NC 27560
Tel. +1-919-572-2705
Fax +1-919-572-2818
info@us.schunk.com
www.us.schunk.com



ARGENTINA

Ruben Costantini S.A.
Ingeniero Luis Angel Huergo 1320
Parque Industrial
2400 San Francisco-Córdoba
Tel. +54-3564-421033
Fax +54-3564-428877
alejandro.costantini@costantini-sa.com
www.costantini-sa.com



FINLAND

Nurminen Tools Oy
Vanha Vantontie 2
21100 Naantali
Tel. +358-2-4389668
Fax +358-2-4389669
sales@nurminentools.fi
www.nurminentools.fi



ISRAEL

Ilan and Gavish
Automation Service Ltd.
26, Shenkar St.
Qiryat-Arie 49513
P.O. Box 10118,
Petach-Tikva 49001
Tel. +972-3-9221824
Fax +972-3-9240761
sigal@ilan-gavish.com
www.ilan-gavish.co.il



NORWAY

Sivilingeniør Sture Hedlav a.s.
Kjellstad Næringscenter
3400 Lier
Tel. +47-32-846588
Fax +47-32-847017
harald@hedlav.no
www.hedlav.no



SLOVAKIA

BIBUS SK, s.r.o.
Priemyselna 4
94901 Nitra
Tel. +421-37-7412525
Fax +421-37-6516701
hrivnak@bibus.sk
www.bibus.sk



THAILAND

Zion Co., Ltd.
1213/54 Ladphrao 94 (Panjamit)
Khwaeng / Khet Wangthonglang
Bangkok 10310
Tel. +66-2-559-3379/81
Fax +66-2-559-3382
zion@asianet.co.th



AUSTRALIA

ROMHELD AUTOMATION PTY. LTD.
Unit 30 / 115 Woodpark Road
Smithfield NSW 2164
Tel. +61-2-9721 1799
Fax +61-2-9721 1766
sales@romheld.com.au
www.romheld.com.au



GREECE

Georg Gousoulis Co. O.E.
27, Riga Fereou Str.
14452 Metamorfosi-Athens
Tel. +30-210-2846771/2
Fax +30-210-2824568
mail@gousoulis.gr
www.gousoulis.gr



POLAND

BIBUS MENOS Sp. z o.o.
UL. Tadeusza Wendy 7/9
81-341 Gdynia
Tel. +48-586609596
Fax +48-586617132
nk@bimen.com.pl
www.bimen.com.pl



SLOVENIA

MB-Naklo
Trgovsko Podjetje D.O.O.
Toma Zupana 16
04202 Naklo
Tel. +386-42-771700
Fax +386-42-771717
mb-naklo@mb-naklo.si
www.mb-naklo.si



UKRAINE

DE&TC «Contact» JSC
5, Kabardinskaya str.
49006, Dnipropetrovsk
Tel. +38-0562-317614
Fax +38-0562-317646
admin@kontak.dp.ua
www.kontakt.dp.ua



BRAZIL

Prodromus Comercio de
Equipamentos
Para Automação LTDA
Av. Gen. Cavacanti de
Albuquerque, 123
CEP 05638-010 São Paulo, SP
Tel. +55-11-37410897
Fax +55-11-37467997
prodromus@prodromus.com.br
www.prodromus.com.br



HUNGARY

IMI International KFT.
Norgren Division
Nagykőrösi UT 99
1205 Budapest
Tel. +36-1-421-4031
Fax +36-1-284-8980
tamas.kesmarki@norgren.hu
www.norgren.hu



JAPAN

BIG Daishowa Seiki Co., Ltd.
Aihara Koyamada Juei 510,
Goshiki-cho, Sumoto-shi,
Hyogo, 656-1317, Japan
Tel. +81-799-320115
Fax +81-799-320117
export@big-net.ne.jp
www.big-net.ne.jp



Kitagawa Iron Works Co. Ltd.
77-1 Motomachi
Fuchu-shi, Hiroshima 726-8610
Tel. +81-847-454560
Fax +81-847-458911
kouki@kiw.co.jp
www.kiw.co.jp



ROMANIA

S.C. INMAACRO S.R.L.
Industrial Machines and
Accessories Romania
Bronzului 7, Bl. 509A, AP 8
500169 Brasov
Tel. +40-268-423450
Fax +40-268-423045
dan.popescu@inmacro.com
www.inmacro.com



SOUTH AFRICA

AGM Maschinenbau (Pty) Ltd.
P.O. Box 4246
Germiston South, 1411
Tel. +27-11-825-4246
Fax +27-11-872-0690
agrau@iafrica.com
www.agm-maschinenbau.co.za



VENEZUELA

Alpin de Venezuela, C.A.
Calle G - Residencias Rosita
Local No. 6-P.B.-El Paraiso
Sector El Pinar-Caracas 1020
Tel. +58-212-4510484
Fax +58-212-4515886
alpvnet@cantv.net



CHILE

Sanches Blanes S.A.
Estrada de Sapopemba, KM 41
CEP 09436-000 Ribeirão Pires, SP
Tel. +55-11-48242742
Fax +55-11-48279009
ventas@sanchesblanes.com.br
www.sanchesblanes.com.br



ICELAND

Formula 1 ehf
Breidamörk 25
P.O. Box 1 61
810 Hveragerdi
Tel. +354-5172200
Fax +354-5172201
formula1@formula1.is



CROATIA

BIBUS Zagreb d.o.o.
Anina 91
10000 Zagreb
Tel. +385-13818006
Fax +385-13818005
bibus@bibus.hr
www.bibus.hr



INDONESIA

PT. Metaltch Indonesia
Jl. Gatot Subroto Km. 8
Tangerang 15136
Tel. +62-21-55657435
Fax +62-21-5912155
santek_trade@yahoo.com



CZECH REPUBLIC

BIBUS s.r.o.
Videňská 125
63927 Brno
Tel. +420-5 47 12 53 26
Fax +420-5 47 12 53 10
adam@bibus.cz
www.bibus.cz



MALAYSIA

SK-TEC
Automation & Engineering Sdn. Bhd
No. 56-A, Jalan PU7/3
47100 Puchong,
Selangor Darul Ehsan
Tel. +603-8060-8771
Fax +603-8060-8772
jeffery.koo@sk-tec.com.my



SINGAPORE

Balluff Asia Pte Ltd.
BLK 1004,
Toa Payoh Industrial Park
Lorong 8, # 03-1489
Singapore 319076
Tel. +65-62524384
Fax +65-62529060
alvin@balluff.com.sg
www.balluff.com.sg



APS - Automation & Production
Systems PTE. Ltd.
46, East Coast Road
06-03, Eastgate
Singapore 428766
Tel. +65-64695810
Fax +65-68994412
apspl@singnet.com.sg



Eureka Tools Pte Ltd
194 Pandan Loop
04-10 Pantech
Industrial Complex
Singapore 128383
Tel. +65-68745781
Fax +65-68745782
eureka@eureka.com.sg
www.eureka.com.sg



SOUTH KOREA

MAPAL HITECO Co., Ltd.
1NA-502, Shihwa Ind. Complex
1254-10, Jungwang-dong,
Shihung-city
Kyunggi-do, 429-450
Tel. +82-31-3190-860
Fax +82-31-3190-861
hiteco@kornet.net
www.hiteco.co.kr



TAIWAN

Yonchin Enterprises, Inc.
P.O. Box 26-13
5F, No. 100,
Hsing Der Rd.,
San Chung City 241, Hsin Taipei
Tel. +886-2-2278-9330
Fax +886-2-2278-9320
yon.chin@msa.hinet.net



Danyao Trading Co., Ltd.
7 F, No. 19, Chung-Cheng Rd.
Hsin Chuang City, 242
Taipei County, Taiwan
Tel. +886-2-22768200
Fax +886-2-22767573
E-Mail: danyao@ms22.hinet.net

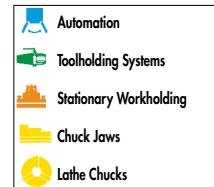

Germany



Lauffen/Neckar, Sales and Production Toolholding and Workholding

SCHUNK GmbH & Co. KG · Spann- und Greiftechnik
 Bahnhofstr. 106 - 134 · 74348 Lauffen/Neckar
 Tel. +49-7133-103-0 · Fax +49-7133-103-2399
 info@de.schunk.com · www.schunk.com



Brackenheim-Hausen, Sales and Production Automation

SCHUNK GmbH & Co. KG · Spann- und Greiftechnik
 Robert-Bosch-Str. 12 · 74336 Brackenheim-Hausen
 Hotline Technical Sales +49-7133-103-2503
 Hotline Technical Support +49-7133-103-2696
 Fax +49-7133-103-2189
 automation@de.schunk.com · www.schunk.com



Mengen, Sales and Production Lathe Chucks

H.-D. SCHUNK GmbH & Co. Spanntechnik KG
 Lothringer Str. 23 · 88512 Mengen
 Tel. +49-7572-7614-0 · Fax +49-7572-7614-1099
 futter@de.schunk.com · www.schunk.com

International



Morrisville/North Carolina, USA

SCHUNK Intec Inc.
 211 Kitty Hawk Drive · Morrisville, NC 27560
 Tel. +1-919-572-2705 · Fax +1-919-572-2818
 info@us.schunk.com · www.us.schunk.com



Hangzhou, China

SCHUNK Precision Machinery (Hangzhou) Co., Ltd.
 6, 24th Street, HEDA · Hangzhou 310018
 Tel. +86-571-8672-1000 · Fax +86-571-8672-8800
 info@cn.schunk.com · www.cn.schunk.com

Copyright

All text drawings and product illustrations are subject to copyright and are the property of SCHUNK GmbH & Co. KG

Technical Changes

The data and illustrations in this catalogue are not binding and only provide an approximate description. We reserve the right to make changes to the product delivered compared with the data and illustrations in this catalogue, e.g. in respect of technical data, design, fittings, material and external appearance.

Copy, complete, fax to

+49-7133-103-2189

Company _____

Name _____

Department _____

Street _____

ZIP _____ City _____

Tel. _____ Fax _____

Order



Pos.	Quantity	Type	ID
1			
2			
3			
4			
5			
6			
7			
8			
9			
10			

The general terms of sales and conditions of SCHUNK GmbH & Co. KG apply

Date _____ Signature _____



SCHUNK GmbH & Co. KG
Spann- und Greiftechnik
 Bahnhofstr. 106 - 134
 D-74348 Lauffen/Neckar
 Hotline Technical Sales +49-7133-103-2503
 Hotline Technical Support +49-7133-103-2696
 Fax +49-7133-103-2189
 automation@de.schunk.com
 www.schunk.com



Reg. No. DE-003496 QM



Catalog Order

Copy, complete, fax to

+49-7133-103-2779

Automation



Gripping Modules



Rotary Modules



Linear Modules

Complete program Automation



Robot Accessories



Modular Assembly Technology



Machine Vision

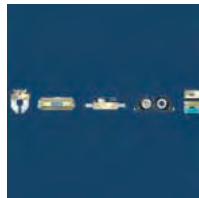

Product Overview

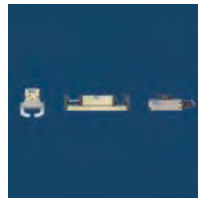

System GEMOTEC
Product Overview



Modular Robotics



Industry Solutions



Highlights
New Products

Toolholding and Workholding



Toolholding Systems



Stationary Workholding



Lathe Chucks

Complete program Toolholding and Workholding



Chuck Jaws



Product Overview



Hydraulic Expansion Technology
Special Solutions



Magnetic Clamping
Technology

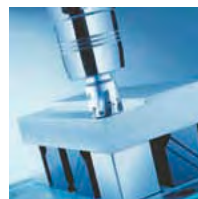

Highlights
New Products

Company _____

Name _____

Department _____

Street _____

ZIP _____ City _____

Tel. _____ Fax _____



SCHUNK GmbH & Co. KG
Spann- und Greiftechnik
Bahnhofstr. 106 - 134
D-74348 Lauffen/Neckar
Tel. +49-7133-103-0
Fax +49-7133-103-2399
info@de.schunk.com
www.schunk.com



Reg. No. DE-003496 QM

// The desire to automate handling applications is our
inspiration for solutions that help you succeed. //

Heinz-Dieter Schunk



www.schunk.com