



Sizes
85



Weight
1.35 kg



Ring diameter O.D. Assembly
appr. \varnothing 5 mm .. \varnothing 160 mm



Ring diameter I.D. Assembly
appr. \varnothing 10 mm .. \varnothing 120 mm

Application example

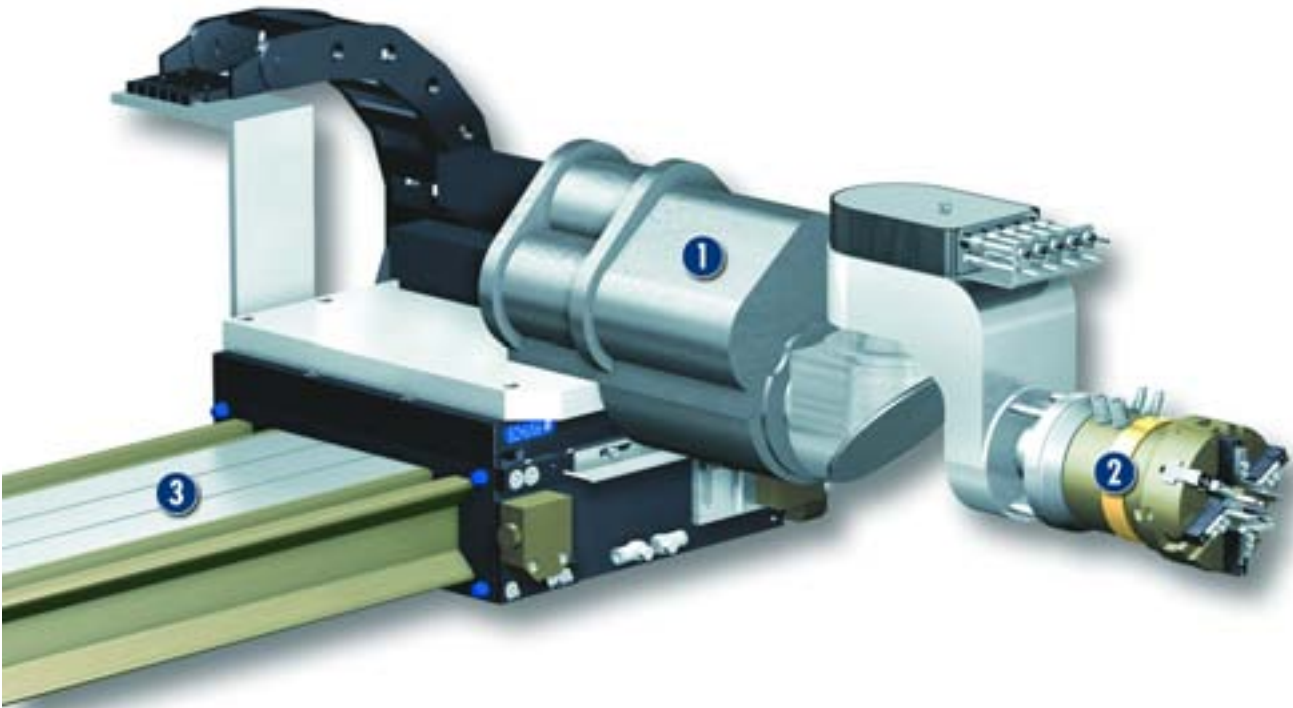

Automatic machine for the internal or external assembly of O-rings with a wide range of diameters

- 1 CAY 15 Handling Axis
- 2 ORG 85 O-ring Gripper

- 3 Linear Axis with Direct Drive MLD 200T

O-ring Assembly Gripper

Grippers equipped with the corresponding top jaw fingers, can assemble o-rings and mostly square rings or other rings, too, but also shafts (O.D. assembly) as well as bores (I.D. assembly).

Area of application

The gripper should be used in a clean environment, particularly in automated assembly.

Your advantages and benefits

O.D. and I.D. assembly with one gripper

for flexibility and cost-saving

„Controlled production“ due to a new assembly principle

for high availability

Standard assembly finger for O.D. Assembly

for conventional ring sizes for fast commissioning



General information on the series

Working principle

Two independent finger triples shape the o-ring which will be then assembled.

Base jaw material

Steel

Housing material

Aluminium

Actuation

pneumatic, via filtered compressed air (10 µm): dry, oiled, or not lubricated pressure medium: Requirements on quality of the compressed air according to DIN ISO 8573-1: 6 4 4.

Warranty

24 months

Scope of delivery

Gripper with assembly- and operating manual, and manufacturer's declaration

Sectional diagram

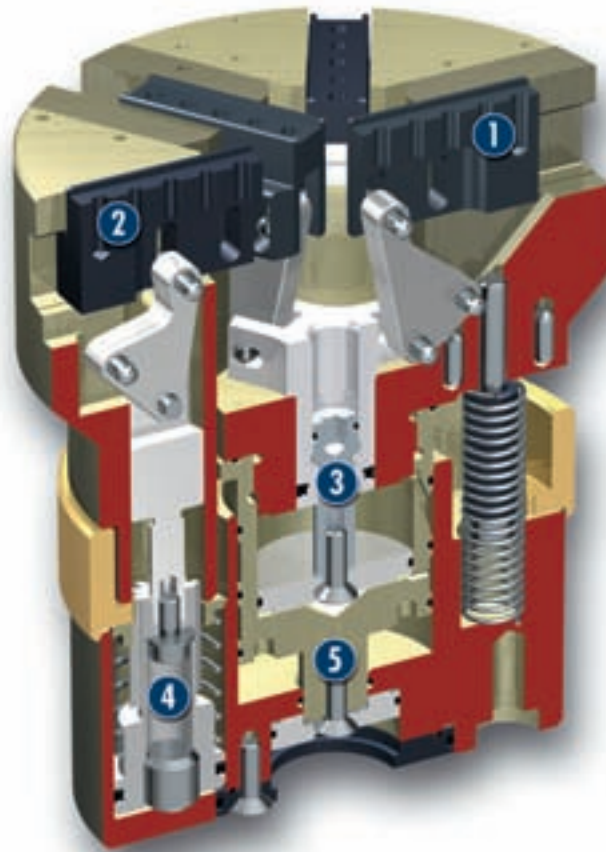

1 Triple jaw A
double-acting

2 Triple jaw B
single-acting

3 Drive
for triple jaw A

4 Drive
for triple jaw B

5 Drive
for linear stroke

Function description

O.D. assembly

The o-ring is expanded by six fingers, the gripper is moved onto the assembly groove of the shaft. The three fingers of the triple jaw A will be retracted with a linear stroke first. The o-ring is already partially inserted in the groove, due to the triangle shape, which occurs since the three jaws of the triple jaw B are holding the o-ring now. The complete gripper is retracted now. The o-ring retracts into its assembly groove automatically now.

I.D. assembly

The segment jaws of triple B and the bar fingers of triple A are positioning the o-ring into the shape of a cloverleaf. The gripper is moved with its fingers into the assembly bore. The segment jaws push the o-ring in a large part of the groove's circumference into the groove. The bar fingers are retracted, the o-ring continues to be inserted in the groove. The bar fingers are inside the o-ring now and the segment jaws push the o-ring imperatively into its groove.

Options and special information

For conventional o-ring sizes SCHUNK offers standard assembly fingers for O.D. assembly. Assembly fingers for I.D. assembly differentiate according to the o-rings. On request, SCHUNK is offering customized products or which can be manufactured by the customer himself. You will find detailed drawings and engineering instructions in our operating manual.

The pdf files are ready for download under: www.schunk.com.

Accessories

Accessories from SCHUNK — the suitable complement for the highest level of functionality, reliability and controlled production of all automation components.

Centering sleeves



Fittings



IN inductive proximity switches



KV/KA sensor cables



Assembly finger



V sensor distributors



General information on the series

Drawings and engineering instructions

For more information on drawings and engineering instructions of assembly fingers, please consult our operating manual for ORG. The pdf-file can be downloaded under www.schunk.com

Gripping force

is the arithmetic sum of the individual forces occurring at the base jaws at a distance P (see drawing), measured from the upper edge of the gripper.

Finger length

is measured from the upper edge of the gripper housing in the direction of the main axis.

Repeat accuracy

is defined as diffusion of the end position after 100 consecutive strokes



Assembly process I.D. assembly



1. Mounting of the o-ring.

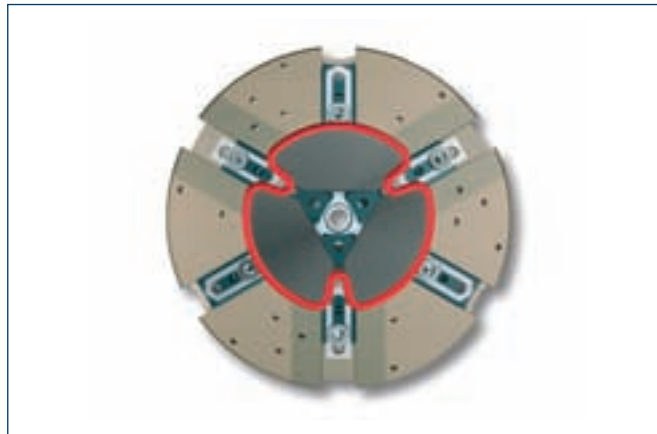

2. Shaping the o-ring into the shape of a cloverleaf.



3. Travel into the bore (assembly position) and pressing by triple jaw B.



4. Pressing by triple jaw A and retraction of the gripper

Assembly process O.D. assembly



1. Mounting of the o-ring and expansion to a hexagon.



2. Travel to the shaft (assembly position).



3. Retraction of triple jaw A. The o-ring inserts into the groove.



4. Retraction of the whole gripper. The o-ring is completely inserted in the groove now.





Finger load

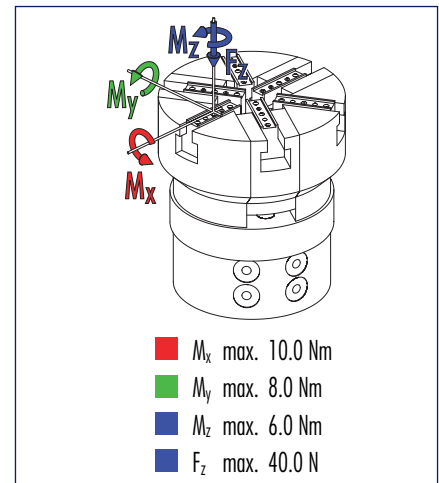

① Moments and forces apply per base jaw and may occur simultaneously. M_y may arise in addition to the moment generated by the gripping force itself. If the max. permitted finger weight is exceeded, it is imperative to throttle the air pressure so that the jaw movement occurs without any hitting or bouncing. Service life may reduce.

Technical data

Description		ORG 85
ID	ID	0304120
No. of fingers		6
Triple jaw A: Principle of function		double-acting
Triple jaw A: Stroke per finger	[mm]	21.0
Triple jaw A: Closing force	[N]	45.0
Triple jaw A: Opening force	[N]	55.0
Triple jaw A: Drawback stroke	[mm]	5.0
Triple jaw A: Drawback force	[N]	20.0
Triple jaw B: Principle of function		single-acting
Triple jaw B: Stroke per finger	[mm]	15.0
Triple jaw B: Opening force	[N]	125.0
Weight	[kg]	1.35
Nominal pressure	[bar]	6.0
Minimum pressure	[bar]	4.0
Maximum pressure	[bar]	8.0
Max. permitted finger length	[mm]	60.0
IP class		40
Min. ambient temperature	[°C]	-10.0
Température ambiante max.	[°C]	90.0
Repeat accuracy	[mm]	0.02

① Principally o-rings can be assembled, depending on the shape (o-ring, square ring, ...), shore hardness, I.D. and string thickness as well as assembly depth. Basically for O.D. assembly o-rings from $\varnothing 5$ to $\varnothing 160$ can be assembled, in case of I.D. assembly o-rings from $\varnothing 10$ to $\varnothing 120$. For last control if they are mountable, please contact SCHUNK

Main views

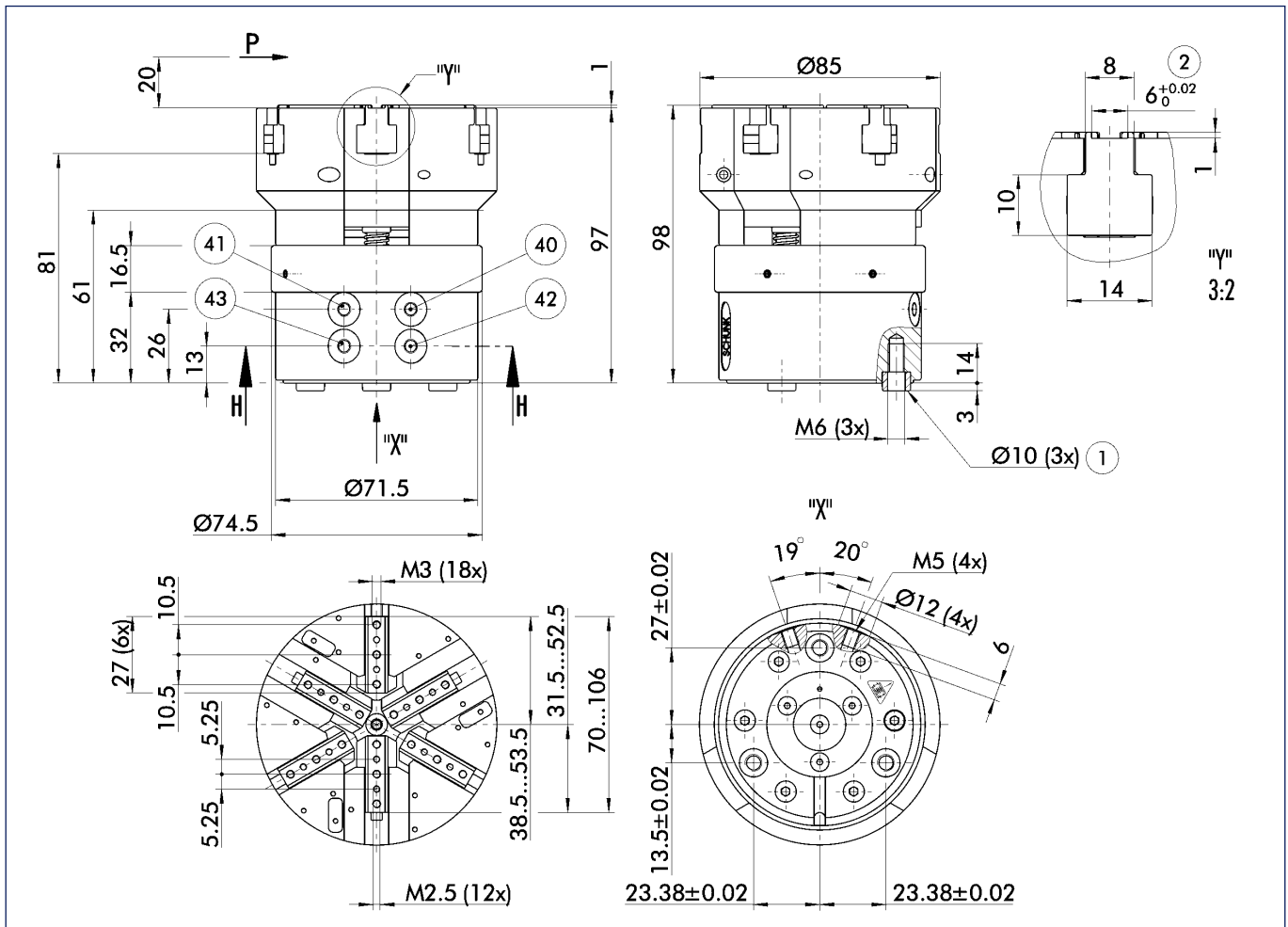

The drawing shows the gripper in the basic version with closed jaws, the dimensions do not include the options described below.

- ① Gripper connection
- ② Finger connection
- ④ Connection gripper triple jaw A opens
- ④ Connection gripper triple jaw A closes
- ④ Connection gripper triple jaw B opens
- ④ Connection Z-stroke unit run-in

Mounting kit for proximity switch

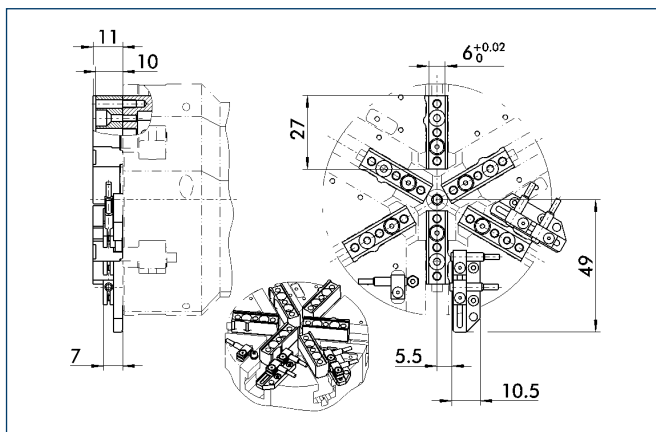

The mounting kit consists of brackets, switch cams and the associated mounting materials. The proximity switches must be ordered separately.

Description	ID
AS-ORG 85	0304129

Concept for I.D. assembly

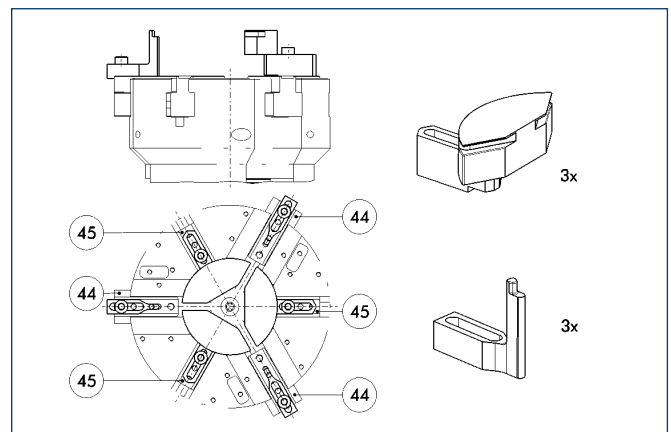

- ④ Triple jaw A
- ④ Triple jaw B

For I.D. assembly three finger shapes and three bar fingers are required. Its geometry depends on the dimensions of the rings to be assembled. Engineering instructions are shown in the operating manual which can be downloaded under ORG. SCHUNK offers engineering works and manufacturing on request.

O.D. assembly: Assembly finger 0.5 .. 1.0

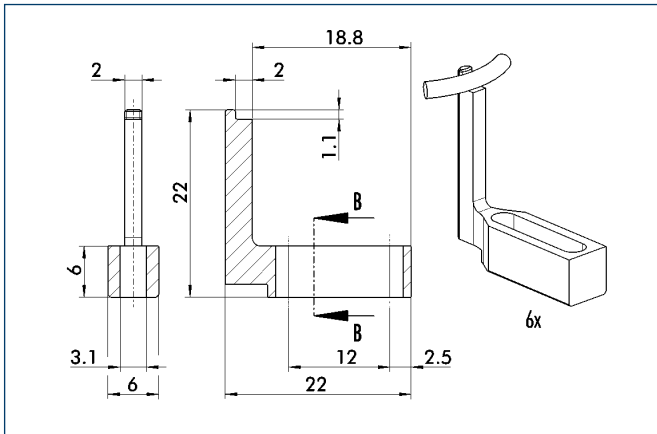

Standard finger for O.D. assembly of rings with a string thickness from 0.5 mm to 1 mm.

Description	Material	Scope of delivery	ID
MFA-D2-0.5-1.0-ORG 85	Aluminum	1	0304113

① Six fingers are required.

O.D. assembly: Assembly finger 1.0 .. 2.0

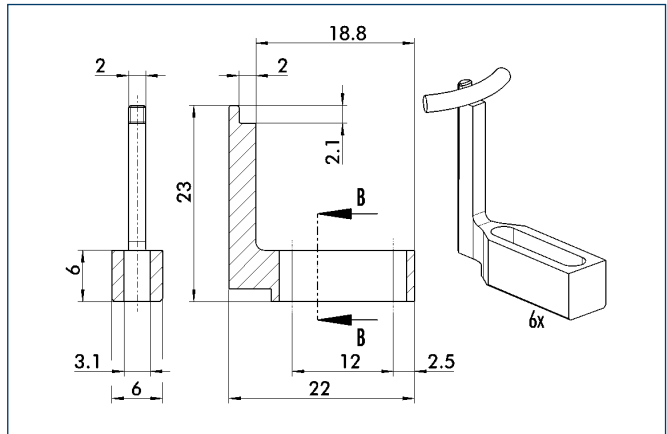

Standard finger for O.D. assembly of rings with a string thickness from 1.0 mm to 2.0 mm.

Description	Material	Scope of delivery	ID
MFA-D2-1.0-2.0-ORG 85	Aluminum	1	0304114

① Six fingers are required.

O.D. assembly: Assembly finger 2.0 .. 3.0

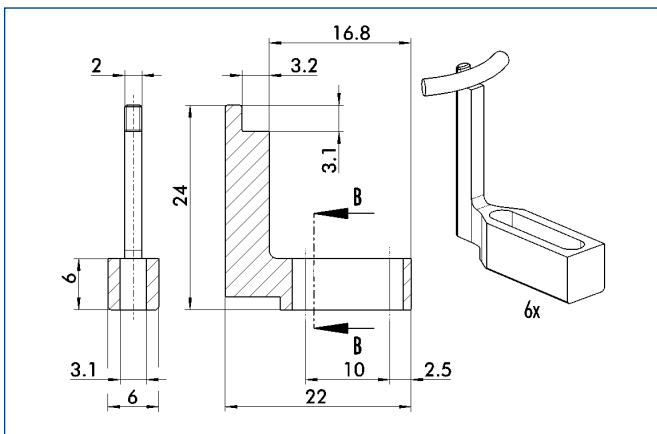

Standard finger for O.D. assembly of rings with a string thickness from 2.0 to 3.0 mm.

Description	Material	Scope of delivery	ID
MFA-D2-2.0-3.0-ORG 85	Aluminum	1	0304115

① Six fingers are required.

O.D. assembly: Assembly finger 3.0 .. 4.0

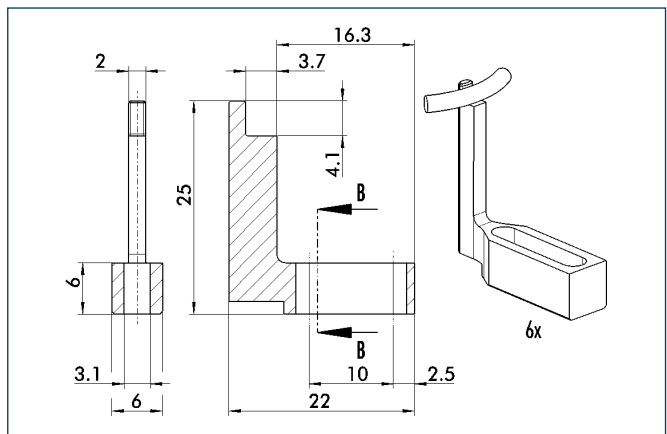

Standard finger for O.D. assembly of rings with a string thickness from 3.0 mm to 4.0 mm.

Description	Material	Scope of delivery	ID
MFA-D2-3.0-4.0-ORG 85	Aluminum	1	0304116

① Six fingers are required.



You can find more detailed information and individual parts of the above-mentioned accessories in the „Accessories“ catalog section.

Sensor system

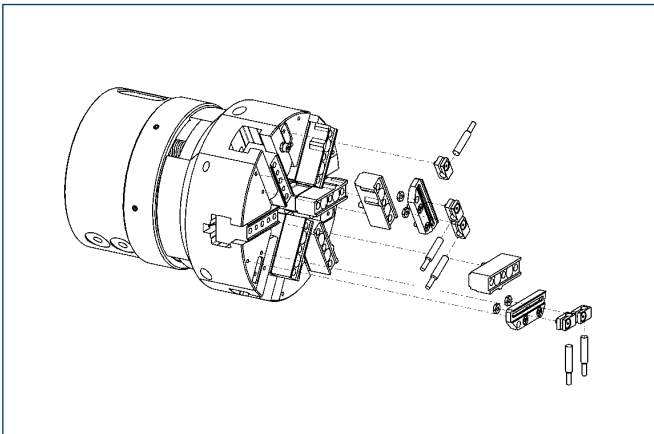

End position monitoring:
Inductive proximity switches, mounted with mounting kit

Description	ID
IN 3-S-M8-PNP	0301466

① Per gripper five sensors (closers/S) are required as well as optionally an extension cable.

Extension cables for proximity switches/magnetic switches

Description	ID
GK 3-M8-PNP	0301622
KV 10-M8-PNP	0301496
KV 20-M8-PNP	0301497
KV 3-M8-PNP	0301495
WK 3-M8-PNP	0301594
WK 5-M8-PNP	0301502

① Please note the minimum permitted bending radii for the sensor cables, which are generally 35 mm.



You can find more detailed information and individual parts of the above-mentioned accessories in the „Accessories“ catalog section.