

COMPACT DRIVE®

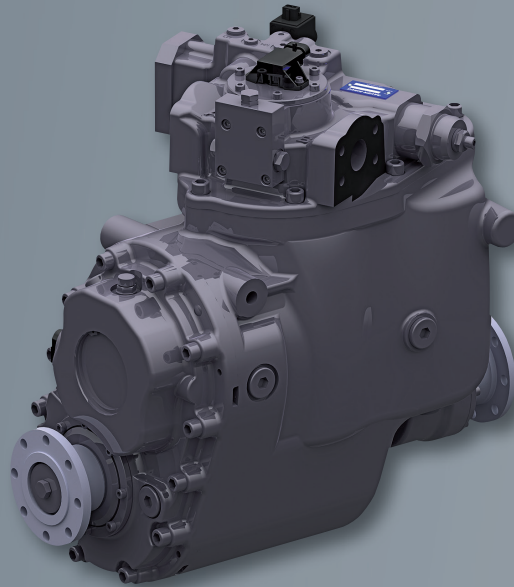

Advantages at a glance:

- Variable bent axis motor with an integrated transfer case
- Area of applications: Drives for agricultural and construction machinery in open and closed circuit
- Continuously variable over whole swivel range
- Low pressure control (LP)
- High pressure control (HP)
- Supplementary motor for additional traction force optional
- Optimised for drive controls e.g. SAUER BIBUS
- Optimised for modular drive systems e.g. SAUER BIBUS
- Compatible to ICVD

Special features:

- 233 ccm / rev displacement
- Swivel angle 45°; high hydraulic conversion range
- Gear ratio from $i=0.94$ to $i=1.64$
- LP Control
 - electro-proportional closed-loop
 - swivel angle sensor
 - flashing valve optional
 - compact design
 - few components
 - external control pressure
 - high-pressureports 1 1/4"
- HP Control
 - electro-proportional
 - hydraulic-proportional optional
 - high-pressureports 1"
- Redundant speed sensor
- Temperature sensor optional
- Driveline flanches

Circuit diagram: LP

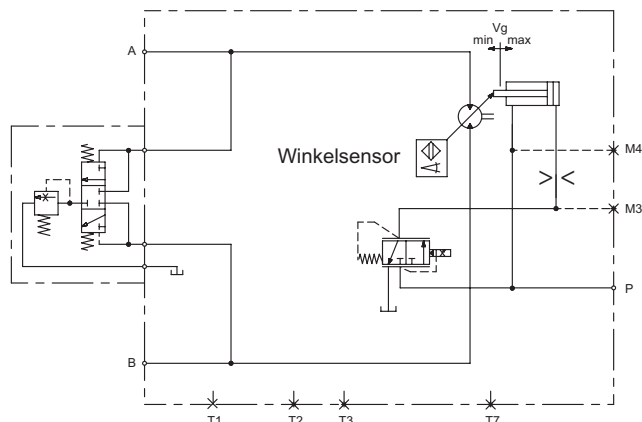

Connections:

A, B SAE 1 1/4", Code 62 T1, T2 M26x1,5
 P M14x1,5 T3, T7 M14x1,5
 M3, M4 M14x1,5

Technical data:

→ Nominal speed (rotation group)	at 45°	1.600 1/min
	at 7°	4.100 1/min
	at 0°	4.300 1/min
→ Max. speed (rotation group)	at 45°	1.900 1/min
	at 7°	4.300 1/min
	at 0°	4.500 1/min
→ Nominal pressure		$\Delta p = 450$ bar
→ Peak pressure	intermittend	$\Delta p = 510$ bar
→ Output Torque ($\Delta p = 450$ bar)	LP-control at V_{gmax}	1.500 to 2.900 Nm
	HP-control at V_{gmax}	1.450 to 2.800 Nm
→ Control pressure	LP	$\Delta p = 25$ bar ext.
	HP	$\Delta p = 450$ bar intern.
→ Case pressure	nomin. press.	3 bar
	peak press.	5 bar
→ Weight	LP	approx. 160 kg
	HP	approx. 165 kg

Dimensions:

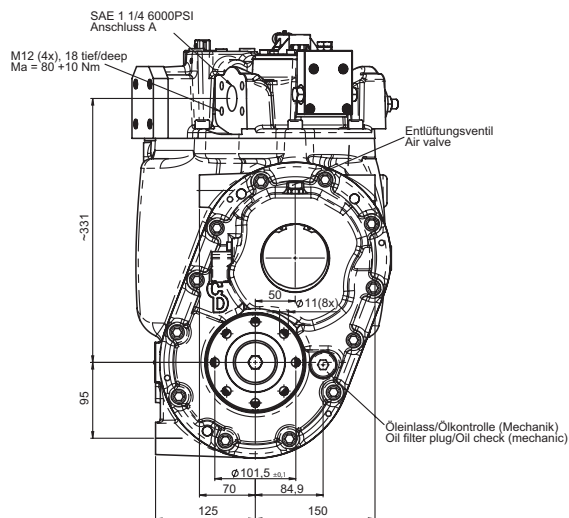
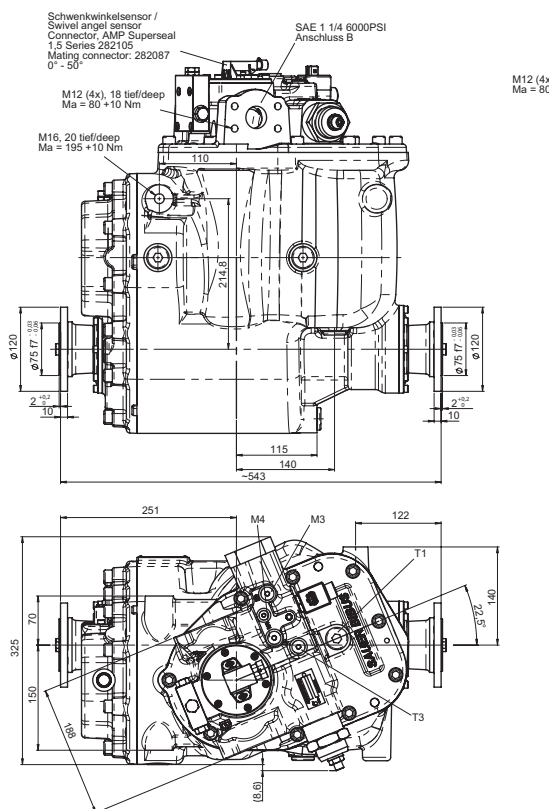

→ Detailed installation drawing on request