

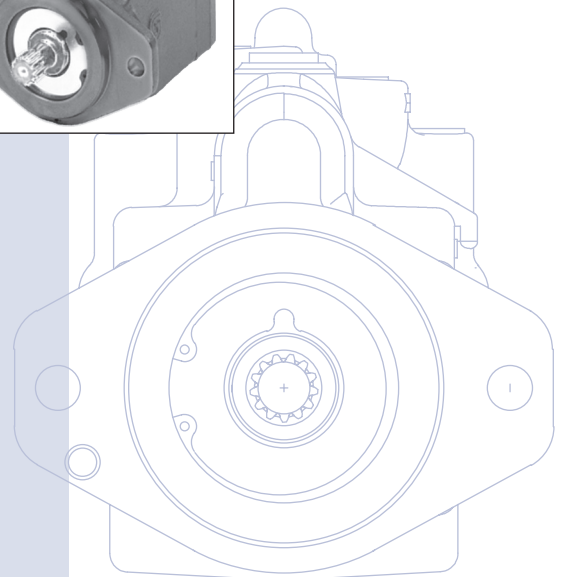

L and K Frame Variable Motors

Technical Information

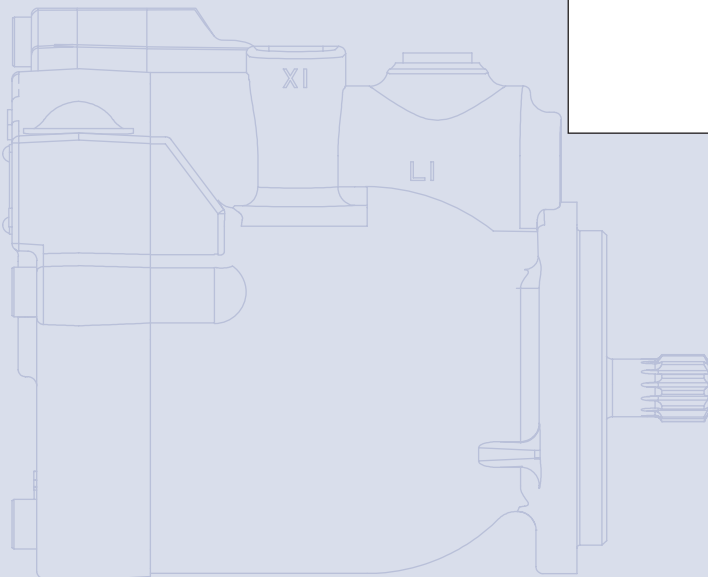
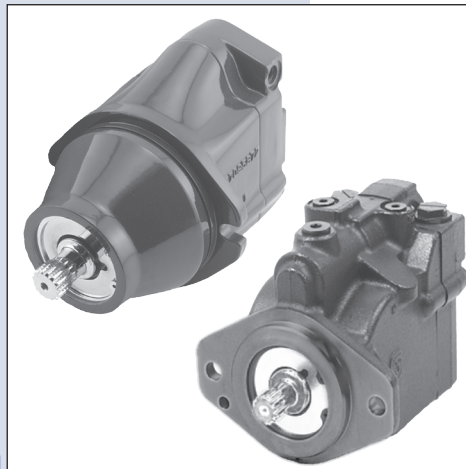
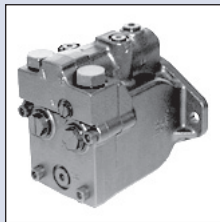
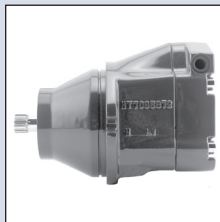

Revisions

Table of Revisions

Date	Page	Changed	Rev.
October 2012	all	edits to various pages	BG
September 2009	7, 16	L35 Max. pressure 300 bar [4350 psi], and speed ring pulses L = 41, K = 44	BF
April 2008	6	corrected the schematic drawings	BE
January 2008	17	removed displacement limiter setting F12 - 65.3%	BD
April 2007	18	LV (41 pulses/rev) KV (44 pulses/rev)	BC
March 2007	18	changed 41 pulses/rev to 44 pulses/rev	BB
October 2006	Various	Added Loop flushing valve and 5 bolt endcap	B
February 2004	-	First edition	A

© 2012 Sauer-Danfoss. All rights reserved.

Sauer-Danfoss accepts no responsibility for possible errors in catalogs, brochures and other printed material. Sauer -Danfoss reserves the right to alter its products without prior notice. This also applies to products already ordered, provided that such alterations can be made without affecting agreed specifications. All trademarks in this material are properties of their respective owners. Sauer-Danfoss, the Sauer-Danfoss logotype, the Sauer-Danfoss S-icon, PLUS+1™, What really matters is inside® and Know-How in Motion™ are trademarks of the Sauer-Danfoss Group.

General Information	Basic Design	4
	Key Features	4
	System Circuit Diagram.....	5
	Schematic Diagrams	5
Technical Specifications	Overview	6
	Features and Options.....	6
	Specifications.....	6
	Operating Parameters	6
	Fluid Specifications.....	6
Operating Parameters	Fluids.....	7
	Viscosity.....	7
	Temperature.....	7
	Charge Pressure	7
	Case Pressure	7
	Shift Pressure	8
	System Pressure	8
	Input Speed	9
System Design Parameters	Installation	10
	Filtration.....	10
	Reservoir.....	10
	Overpressure Protection.....	10
	Loop Flushing	11
	Charge Flow	11
	Charge Pressure	11
	Redundant Braking System Requirement	11
	Series Operation	11
	Shaft Loads	12
	Duty Cycle and Bearing Life.....	12
	Hydraulic Equations Helpful for Motor Selection	13
	Name Plate.....	13
Product Coding	Model Code	14
Features and Options	Speed Sensor	16
	Shaft Torque	16
	Loop Flushing	17
	Dust Seal Option.....	18
	Displacement Limiters.....	22
	Motor Rotation	22
	Controls.....	22
	Brake Release Port (cartridge motors)	22
Control orificing	22	
Installation Drawings	SAE-B Mount (LV/KV).....	23
	Cartridge (LC/KC).....	26

Basic Design

The L and K Frame variable motors are light to medium power two-position axial piston motors incorporating an integral servo piston. They are designed for operation in closed and open circuit applications. The L and K Frame motors consist of five unique rotating groups (displacements) and two housing (mounting) configurations. An SAE-B, two-bolt, and a cartridge style (for space-optimized gearbox mounting) configurations are available for each frame. Maximum speeds and maximum applied pressures for each displacement vary. The standard control is a direct acting single line hydraulic control. For SAE-B mount motors a two line control is also available. The integral servo piston controls motor displacement.

The motor is spring biased to maximum displacement and hydraulically shifted to minimum displacement. Minimum and maximum displacement can be set with fixed internal stops. The large diameter servo piston allows smooth acceleration and deceleration with relatively large circuit orificing.

The motor is ideally configured for installations requiring compact packaging and optimized plumbing, such as wheel ends. One face of the motor contains all hydraulic porting. Two standard porting configurations are available: twin radial (side) or axial (end) O-ring boss main ports.

Cross section, SAE-B mount

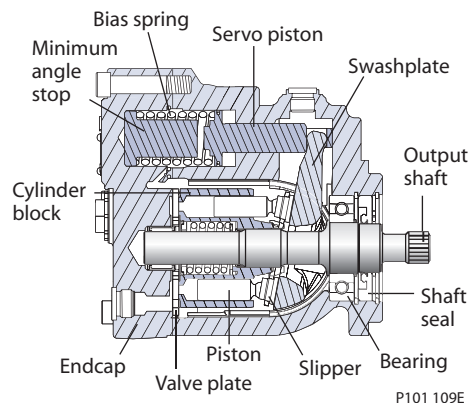

Cross section, cartridge mount

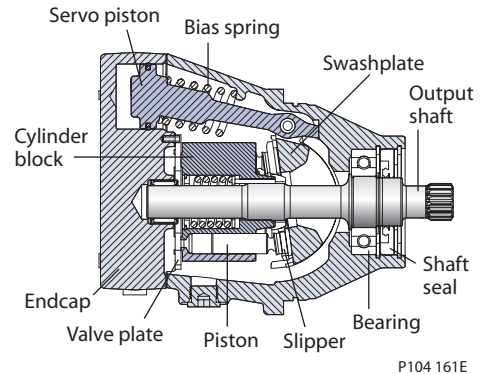

Key Features

- Five displacements allow the optimum selection of hydraulic motor for the lowest possible installed cost.
- SAE-B, two-bolt, and cartridge mounting configurations available.
- Short and compact; fits into existing installation with improved porting.
- Three clean sides with superior clearance and access to mounting bolts.
- High Efficiency - nine piston rotating groups with 18 degree maximum angle.
- Versatility - working displacement range of 3.4:1 with a minimum angle option to one degree overcenter (-1°).
- Reliability - uses existing and proven technology.
- Worldwide service and technical support.

System Circuit Diagram *Pictorial system diagram*

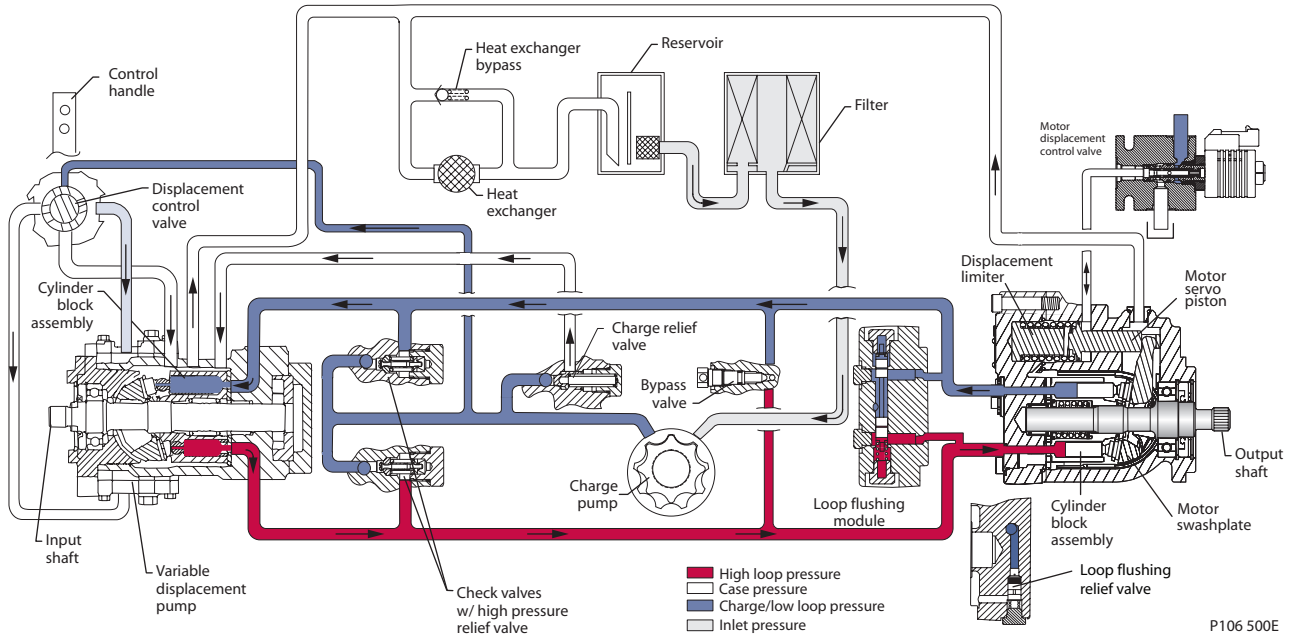

The circuit above shows the LV/KV motor in a simple closed-loop hydrostatic propel application. The motor is driven by a Series 40 M46 axial piston pump with manual displacement control. The motor shown uses a single line hydraulic displacement control. Control pressure applied through an external control valve shifts the motor to minimum displacement, spring force returns the motor to maximum displacement in the absence of control input.

Schematic Diagrams

SAE motor - single or two line control

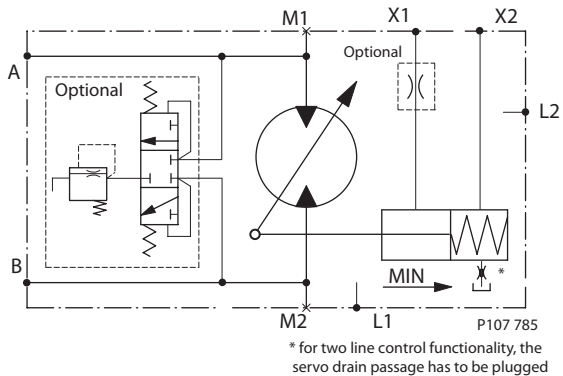

Cartridge motor - single line control

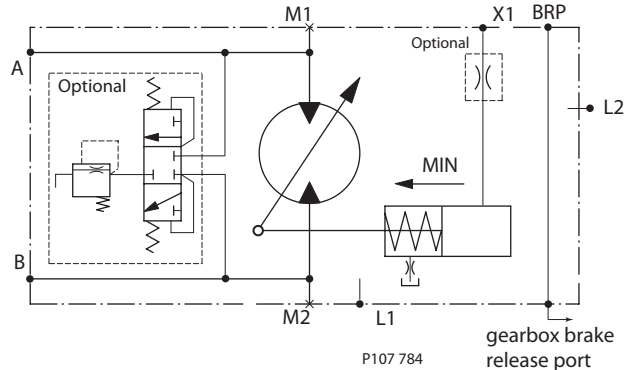

Overview

Specifications and operating parameters for L and K Frame motors are given here for quick reference. For additional information, see *Operating Parameters, Features and Options*, and *Product Coding*.

Features and Options

Mount	SAE-B (LV/KV)	Cartridge (LC/KC)
Motor type	Inline, axial piston, positive displacement, two-speed variable motors	
Displacement	L: 25, 30, or 35 cm ³ [1.50, 1.83, or 2.14 in ³] K: 38 or 45 cm ³ [2.32 or 2.75 in ³]	
Rotation	Bidirectional	
Installation position	Discretionary: Housing must always be filled with hydraulic fluid	
Porting	SAE O-ring boss, axial or twin radial	SAE O-ring boss, twin radial
Output shafts	Splined 13 or 15 tooth 16/32 pitch, 0.875 inch straight keyed, and 1:8 taper	Splined 13 or 15 tooth 16/32 pitch
Control options	Single or dual line hydraulic control	Single line hydraulic control
Displacement limiter	Fixed maximum and minimum displacement limiters available	
Speed sensor	Available - refer to Features and options section	
Loop Flushing Valve	Available - refer to Features and options section	

Specifications

Parameter	Unit	L25	L30	L35	K38	K45
Displacement (maximum)	cm ³ [in ³]	25 [1.50]	30 [1.83]	35 [2.14]	38 [2.32]	45 [2.75]
Weight (cartridge and SAE-B)	kg [lb]	15.4 [34]				
Mass moment of inertia of rotating components	kg·m ² [slug·ft ²]	0.001666 [0.001229]	0.001582 [0.001167]	0.001530 [0.001128]	0.002326 [0.001716]	0.002286 [0.001687]
Theoretical torque	N·m/bar [lbf·in/1000psi]	0.40 [244]	0.48 [293]	0.56 [347]	0.60 [366]	0.72 [439]

Operating Parameters

Parameter	Unit	L25	L30	L35	K38	K45
System pressure	maximum working	400 [5800]	350 [5075]	300 [4350]	350 [5075]	300 [4350]
	maximum	420 [6090]	375 [5440]	325 [4715]	375 [5440]	325 [4715]
Speed limit (at max. disp.)	rated	3400	3500	3600	3600	3500
	maximum	3950	4150	4300	4000	3900
Speed limit (at min. disp., including Zero degrees)	rated	4400	4450	4500	4650	4500
	maximum	5000	5150	5300	5200	5050
Case pressure	maximum working	2 [29]				
	maximum	6 [87]				
Shift pressure (single line control)	maximum working	14 [203]				
	maximum	69 [1000]				

Fluid Specifications

Ratings and data are based on operation with premium petroleum-based hydraulic fluids containing oxidation, rust, and foam inhibitors.

Parameter	Unit	Minimum	Continuous	Maximum
Viscosity	mm ² /sec (cSt) [SUS]	7 [47]	12-60 [70-278]	1600 [7500]
Temperature	°C [°F]	-40 [-40]	82 [180]	104 [220]
Cleanliness		ISO 4406 Class 18/13 or better		
Filtration efficiency	suction filtration	$\beta_{35-44}=75$ ($\beta_{10} \geq 1.5$)		
	charge filtration	$\beta_{15-20}=75$ ($\beta_{10} \geq 10$)		

Fluids

Ratings and performance data for L and K Frame motors are based on operating with premium hydraulic fluids containing oxidation, rust, and foam inhibitors. These include premium turbine oils, API CD engine oils per SAE J183, M2C33F or G automatic transmission fluids (ATF), Dexron II (ATF) meeting Allison C-3 or Caterpillar T0-2 requirements, and certain specialty agricultural tractor fluids. For more information on hydraulic fluid selection, see Sauer-Danfoss publications: *Hydraulic Fluids and Lubricants, Technical Information, 520L0463*, and *Experience with Biodegradable Hydraulic Fluids, Technical Information, 520L465*.

Viscosity

Maintain fluid viscosity within the recommended range for maximum efficiency and bearing life. **Minimum viscosity** should only occur during brief occasions of maximum ambient temperature and severe duty cycle operation. **Maximum viscosity** should only occur at cold start. Limit speeds until the system warms up.

Fluid viscosity limits

Condition	mm ² /s (cSt)	SUS
Minimum	7	47
Continuous	12-60	70-278
Maximum	1600	7500

Temperature

Maintain fluid temperature within the limits shown in the table. **Minimum temperature** relates to the physical properties of the component materials. Cold oil will not affect the durability of the motor components. However, it may affect the ability of the motor to transmit power. **Maximum temperature** is based on material properties. Don't exceed it. Measure maximum temperature at the hottest point in the system. This is usually the case drain.

Temperature limits

Minimum (intermittent, cold start)	- 40° C [- 40° F]
Continuous	85° C [185° F]
Maximum	105° C [221° F]

Ensure fluid temperature and viscosity limits are concurrently satisfied.

Charge Pressure/Open Circuit Operation

L and K Frame motors can be operated in closed and open circuit applications. For a propel motor open circuit, the motor must have a direct line (no combining flows) from the motor case to the reservoir to prevent pressure spikes. When the motor is being operated with zero backpressure, the maximum limit for case pressure is 2 bar.

Case Pressure

Maintain case pressure within the limits shown in the table. The housing must always be filled with hydraulic fluid.

Case pressure limits

Maximum (continuous)	2 bar [29 psi]
Intermittent (cold start)	6 bar [87 psi]

⚠ Caution

Operating outside of charge and case pressure limits will damage the motor. To minimize this risk, use full size inlet and case drain plumbing, and limit line lengths.

Shift Pressure

Minimum shift pressure required to keep motor swashplate at minimum angle is 14 bar [203 psi].

Control input pressure limits

LV/KV with single line control	14 to 240 bar [200 to 3500 psi]
LV/KV with dual line control	14 to 35 bar [200 to 500 psi]
LC/KC with single line control	14 to 69 bar [200 to 1000 psi]

System Pressure

System pressure is the differential pressure between high pressure system ports. It is the dominant operating variable affecting hydraulic unit life. High system pressure, which results from high load, reduces expected life. Hydraulic unit life depends on the speed and normal operating, or weighted average, pressure that can only be determined from a duty cycle analysis.

Application pressure is the high pressure relief or pressure limiter setting normally defined within the order code of the pump. This is the applied system pressure at which the driveline generates the maximum calculated pull or torque in the application.

Maximum working pressure is the highest recommended Application pressure. Maximum working pressure is not intended to be a continuous pressure. Propel systems with application pressures at, or below, this pressure should yield satisfactory unit life given proper component sizing.

Maximum pressure is the highest allowable Application pressure under any circumstance. Application pressures above maximum working pressure will only be considered with duty cycle analysis and factory approval.

Minimum low loop pressure must be maintained under all operating conditions to avoid cavitation.

All pressure limits are differential pressures referenced to low loop (charge) pressure. Subtract low loop pressure from gauge readings to compute the differential.

Input Speed

Minimum speed is the lowest input speed recommended during engine idle condition. Operating below minimum speed limits the pump's ability to maintain adequate flow for lubrication and power transmission.

Rated speed is the highest input speed recommended at full power condition. Operating at or below this speed should yield satisfactory product life.

Maximum speed is the highest operating speed permitted. Exceeding maximum speed reduces product life and can cause loss of hydrostatic power and braking capacity. Never exceed the maximum speed limit under any operating conditions.

Operating conditions between rated speed and maximum speed should be restricted to less than full power and to limited periods of time. For most drive systems, maximum unit speed occurs during downhill braking or negative power conditions. For more information consult **Pressure and Speed Limits, BLN-9884**, when determining speed limits for a particular application.

During hydraulic braking and downhill conditions, the prime mover must be capable of providing sufficient braking torque in order to avoid pump over speed. This is especially important to consider for turbocharged and Tier 4 engines.

▲ Warning

Unintended vehicle or machine movement hazard

Exceeding maximum speed may cause a loss of hydrostatic drive line power and braking capacity. You must provide a braking system, redundant to the hydrostatic transmission, sufficient to stop and hold the vehicle or machine in the event of hydrostatic drive power loss. The braking system must also be sufficient to hold the machine in place when full power is applied.

Installation

L and K Frame motors may be installed in any position. The motor housing must always remain full of hydraulic fluid.

Fill the motor housing and system lines with clean fluid during installation. Connect the case drain line to the uppermost drain port (L1 or L2) to keep the housing full during operation.

To allow unrestricted flow to the reservoir, use a dedicated drain line. Connect it below the minimum reservoir fluid level and as far away from the reservoir outlet as possible. Use plumbing adequate to maintain case pressure within prescribed limits (see *Case pressure limits*, page 7).

Filtration

To prevent damage to the motor, including premature wear, fluid entering the motor must be free of contaminants. L and K Frame motors require system filtration capable of maintaining fluid cleanliness at ISO 4406-1999 class 22/18/13 or better.

Consider these factors when selecting a system filter:

- Cleanliness specifications
- Contaminant ingress rates
- Flow capacity
- Desired maintenance interval

Typically, a filter with a beta ratio of $\beta_{10} = 1.5$ to 2.0 is adequate. However, open circuit systems supplied from a common reservoir may have considerably higher requirements. Because each system is unique, only a thorough testing and evaluation program can fully validate the filtration system. For more information, see Sauer-Danfoss publication, *Design Guidelines for Hydraulic Fluid Cleanliness*, **520L0467**.

Reservoir

The reservoir provides clean fluid, dissipates heat, and removes entrained air from the hydraulic fluid. It allows for fluid volume changes associated with fluid expansion and cylinder differential volumes. Minimum reservoir capacity depends on the volume needed to perform these functions. Typically, a capacity of one half the charge pump flow (per minute) is satisfactory for a closed reservoir. Open circuit systems sharing a common reservoir will require greater fluid capacity.

Locate the reservoir outlet (suction line) near the bottom, allowing clearance for settling foreign particles. Place the reservoir inlet (return lines) below the lowest expected fluid level, as far away from the outlet as possible.

Overpressure Protection

L and K Frame motors have no internal overpressure protection. Therefore, relief valves or pressure limiters are required to maintain system pressure within prescribed limits. Relief valves are adequate to protect against transient or unusually rapid load application, but excessive or continuous flow through them adds heat to the system and can damage the fluid. In applications operating at or near pressure, use a pressure compensating variable pump.

Loop Flushing

Closed circuit systems may require loop flushing to meet temperature and cleanliness requirements. A loop flushing valve removes hot fluid from the low pressure side of the system loop for additional cooling and filtering. Ensure the charge pump provides adequate flow for loop flushing and the loop flushing valve does not cause charge pressure to drop below recommended limits.

Charge Flow

Closed circuit applications require a charge pump to make up for lubrication and cooling losses, and to charge the low pressure side of the system loop. The total charge flow required is a sum of the charge flow requirements for the pump, plus the flow requirements for all motors in the system, plus any external loop flushing requirements. Ensure that adequate charge flow exists under all conditions of engine speed and motor speed and pressure.

Charge Pressure / Open Circuit Operation

L and K frame motors can be operated with zero pressure in the low side of the system loop. The case pressure must not be higher than 2 bar over the low side loop system pressure. With zero backpressure, the maximum allowed case pressure is 2 bar [29 psi]. Case drain lines must be plumbed accordingly to insure this 2 bar case pressure differential is not exceeded under any circumstances.

Redundant Braking System Requirement

▲ Warning

Unintended vehicle or machine movement hazard.

The loss of hydrostatic drive line power, in any mode of operation (forward, neutral, or reverse) may cause the system to lose hydrostatic braking capacity. You must provide a braking system, redundant to the hydrostatic transmission, sufficient to stop and hold the vehicle or machine in the event of hydrostatic drive power loss.

Series Operation

L and K Frame motors may be operated in series configuration as long as system, charge, and case pressure limits are satisfied. Operating motors in series significantly impacts bearing life. Contact your Sauer-Danfoss representative for assistance when applying L and K Frame motors in series configuration.

Shaft Loads

L and K Frame motors have bearings capable of accepting some external radial and thrust loads. The external radial shaft load limits are a function of the load position, orientation, and the operating conditions of the motor.

Shaft external load limits

Frame		L		K	
Mounting configuration		SAE	Cartridge	SAE	Cartridge
Maximum allowable external moment (M_e)	N·M	7.7	21.7	13.3	37.5
	lbf·in	68	192	118	332
Maximum allowable thrust load (T)	N	750		1100	
	lbf	169		247	

The table above gives the maximum allowable external moment (M_e) for a 25% bearing life reduction, with optimum load orientation, operating at maximum continuous pressure (see *Specifications*, page 6). You can compute the allowable radial load (R_e) from the moment (M_e), and the load distance (L) from the mounting flange, using the formula below. The thrust load (T) is the maximum allowable without bearing life reduction, based on the radial load for 25% life reduction and maximum continuous pressure. Maximum allowable thrust load (T) is a function of external radial load and operating pressure, and may or may not impact bearing life. If thrust or radial loads exist that are not a function of the operating load of the motor, or exceed these limits, contact your Sauer-Danfoss representative for application assistance.

Radial load formula

$$M_e = R_e \cdot L$$

- L = Distance from mounting flange to point of load
- M_e = Maximum external moment
- R_e = Maximum radial side load

Shaft load orientation

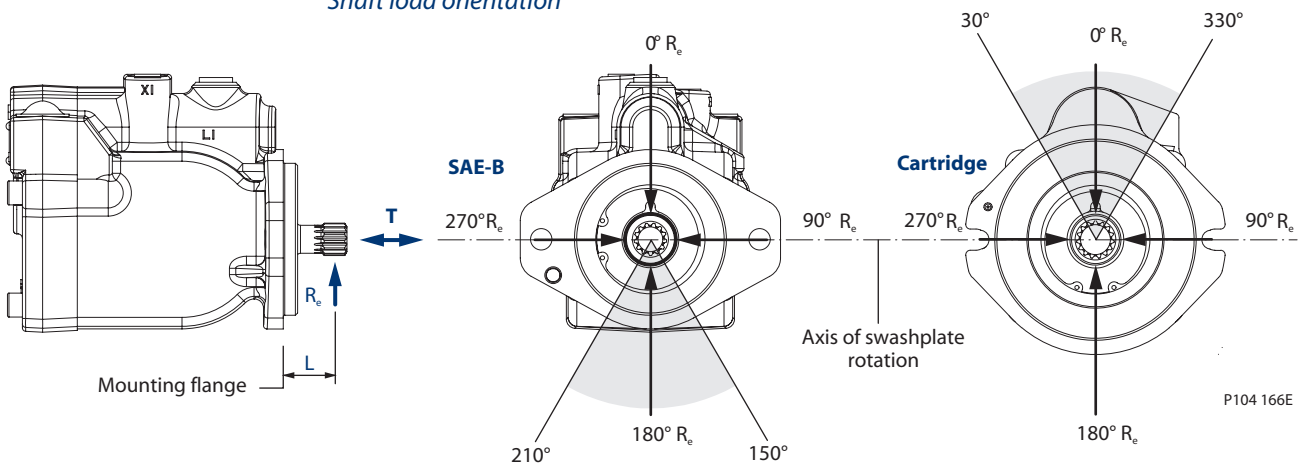

Duty Cycle and Bearing Life

All shaft loads affect bearing life. In applications where external shaft loads exist, maximize bearing life by orientating the load in the optimal position, as shown in the shaded area above. We recommend tapered shafts or clamp-type couplings for applications with radial shaft loads.

Knowing the operating conditions of your application is the best way to ensure proper motor selection. With accurate duty cycle information, your Sauer-Danfoss representative can assist in calculating expected motor life.

Hydraulic Equations Helpful for Motor Selection

Use the following equations to compute output power, torque, speed, and input flow. Selecting the right motor starts with an evaluation of system requirements such as speed and torque. Select a motor that will transmit the required torque, then select a pump that will meet the flow and pressure requirements of the motor. For more information on hydrostatic drive selection, refer to Sauer-Danfoss applications guideline *Selection of Drive Line Components*, **BLN-9885**.

Based on SI units

$$\text{Input flow } Q = \frac{V_g \cdot n}{1000 \cdot \eta_v} \quad (\text{l/min})$$

$$\text{Motor speed } n = \frac{Q \cdot 1000 \cdot \eta_v}{V_g} \text{ min}^{-1}(\text{rpm})$$

$$\text{Output torque } M = \frac{V_g \cdot \Delta p \cdot \eta_m}{20 \cdot \pi} \quad (\text{N}\cdot\text{m})$$

$$\text{Output power } P = \frac{Q \cdot \Delta p \cdot \eta_t}{600} \quad (\text{kW})$$

Based on US units

$$\text{Input flow } Q = \frac{V_g \cdot n}{231 \cdot \eta_v} \quad (\text{US gal/min})$$

$$\text{Motor speed } n = \frac{Q \cdot 231 \cdot \eta_v}{V_g} \text{ min}^{-1}(\text{rpm})$$

$$\text{Output torque } M = \frac{V_g \cdot \Delta p \cdot \eta_m}{2 \cdot \pi} \quad (\text{lbf}\cdot\text{in})$$

$$\text{Output power } P = \frac{Q \cdot \Delta p \cdot \eta_t}{1714} \quad (\text{hp})$$

Where:

SI units [US units]

V_g	= Displacement per revolution	cm^3/rev [in^3/rev]
p_o	= Outlet pressure	bar [psi]
p_i	= Inlet pressure	bar [psi]
Δp	= $p_o - p_i$ (system pressure)	bar [psi]
n	= Speed	min^{-1} (rpm)
η_v	= Volumetric efficiency	
η_m	= Mechanical efficiency	
η_t	= Overall efficiency ($\eta_v \cdot \eta_m$)	

Name Plate

L and K Frame motors are identified by a name plate affixed to the motor housing. The nameplate contains the model number, model code, serial number, and country of manufacture.

Serial number

Every unit is identified by a unique serial number. The serial number gives manufacturing location, year and week built, and a unique sequence number. The serial number in the example to the left is decoded as:

A	Ames, Iowa, USA
11	Year 2011
13	Week 13
67890	Sequence number

Model number

A Sauer-Danfoss model number is issued for every unique configuration. Use this number when placing orders.

Model code

The model code completely defines the options for a specific unit. See *Model code*, next page, for available options and codes.

Name plate



Model Code

A B C1 2 D E 1 2 3 F G H J K 1 2 L M N
 □□ □□□□ □ □□□□ □□□ □ □ □ □□□□ □□□□ □□□□ □□□□

A Frame

Code	Description
L	Frame size: displacements 25, 30, and 35 cm ³ [1.50, 1.83, and 2.14 in ³]
K	Frame size: displacements 38 and 45 cm ³ [2.32 and 2.75 in ³]

B Mount

Code	Description
V	SAE-B
C	Cartridge

C1 Displacement

Code	Displacement
25C	25 cm ³ /rev [1.50 in ³ /rev]
30D	30 cm ³ /rev [1.83 in ³ /rev]
35E	35 cm ³ /rev [2.14 in ³ /rev]
38C	38 cm ³ /rev [2.32 in ³ /rev]
45D	45 cm ³ /rev [2.75 in ³ /rev]

C2 Speed sensing ring

Code	Description
N	None
S	Speed ring installed, L Frame = 41 pulses per revolution, K Frame = 44 pulses per revolution

D Output shaft

Code	Description
A	13 tooth 16/32 pitch per ANSI B92.1-1970 class 5
C	0.875 in straight key (LV/KV only)
D	1:8 taper (LV/KV only)
E	15 tooth 16/32 pitch per ANSI B92.1-1970 class 5
F	1:8 taper/ with dust seal (LV/KV only)

E1 Endcap porting

Code	Description
R	Twin radial, 1 1/16 in-12 O-ring boss
Y	Axial, 1 1/16 in-12 O-ring boss (LV/KV only)

Reference *Loop Flushing* in *Features and Options* and *Technical Specifications* sections.

E2 Loop flushing

Code	Description
N	None (standard), crack pressure 10.3 bar [150 psi]
1	Flow = option 1, crack pressure 10.3 bar [150 psi]
2	Flow = option 2, crack pressure 10.3 bar [150 psi]
3	Flow = option 3, crack pressure 10.3 bar [150 psi]
4	Flow = option 4, crack pressure 10.3 bar (150 psi)

E3 Minimum angle adjustment option

Code	Description
F	Non-adjustable fixed stop

Model Code (continued)

A B C1 2 D E 1 2 3 F G H J K 1 2 L M N
 □□ □□□□ □ □□□ □□□ □□□ □ □□ □□ □□□ □□□ □□□□ □□□□ □□□□

Additional minimum displacements are available, contact your Sauer-Danfoss representative for more information

F Minimum angle/displacement setting

Code	Angle	% of max.	L25C	L30D	L35E	K38C	K45D
F01	1°	5.3%	1.34 cm ³	1.61 cm ³	1.88 cm ³	2.04 cm ³	2.42 cm ³
F07	7°	37.8%	9.45 cm ³	11.34 cm ³	13.23 cm ³	14.36 cm ³	17.00 cm ³
F08	8°	43.2%	10.81 cm ³	12.97 cm ³	15.13 cm ³	16.44 cm ³	19.46 cm ³
F09	9°	48.7%	12.19 cm ³	14.63 cm ³	17.07 cm ³	18.52 cm ³	21.94 cm ³
F10	10°	54.3%	13.57 cm ³	16.28 cm ³	18.99 cm ³	20.62 cm ³	24.42 cm ³
F11	11°	59.8%	14.96 cm ³	17.94 cm ³	21 cm ³	22.73 cm ³	26.92 cm ³
F12	12°	65.1%	16.29 cm ³	19.55 cm ³	22.88 cm ³	24.77 cm ³	29.34 cm ³
F13	13°	70.2%	17.62 cm ³	21.16 cm ³	24.76 cm ³	26.81 cm ³	31.76 cm ³

G Control type

Code	Description
S	Single input hydraulic control
T	Dual input hydraulic control (LV/KV only) (must use X drain orifice)

H Supply orifice

Code	Description
N	None (standard)

J Drain orifice

Code	Description
N	None (standard)
X	Plugged: Required for dual line hydraulic control (use when code G=T) (LV/KV only)

K1 Speed sensor/connector

Code	Description
A	None: Housing not machined for speed sensing (use when code C2=N)
B	None: Housing machined for speed sensor. Port plugged.
C	Speed sensor: 4.5–8.5 V, 4 wire directional, Weather-Pack connector, 200 mm [8 in] lead. KPPG 13408 (internal speed ring required: code C2=S).

K2 Maximum angle adjustment option

Code	Description
F	Non-adjustable fixed stop

L Maximum angle/displacement setting

Code	Angle	% of max.	L25C	L30D	L35E	K38C	K45D
F18	18°	100%	25 cm ³	30 cm ³	35 cm ³	38 cm ³	45 cm ³
F17	17°	94.1%	23.52 cm ³	28.22 cm ³	32.92 cm ³	35.76 cm ³	42.34 cm ³
F16	16°	88.2%	22.06 cm ³	26.47 cm ³	30.88 cm ³	33.54 cm ³	39.71 cm ³
F15	15°	82.5%	20.62 cm ³	24.74 cm ³	—	31.34 cm ³	37.11 cm ³

M Special hardware

Code	Description
NNN	None (standard)

N Special features

Code	Description
NNN	None (standard)

Speed Sensor

K and L Frame motors are available with an optional speed sensor. This hall-effect pick-up senses motor speed and direction of rotation via a magnetic ring mounted to the cylinder block. The sensor is available with a 4-pin Packard Weather-Pack connector. For more information, refer to *Technical Bulletin, KPP Pulse Pick-up, BLN-95-9045*.

KPP Pulse Pick-up with Weather-Pack connector (KPPG13408 PPU shown)

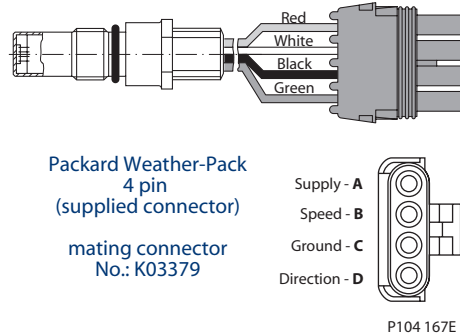

Specifications

Supply voltage	4.5 to 8.5 Vdc (regulated)
Output voltage (high)	Supply minus 0.5 Vdc, minimum (no load)
Output voltage (low)	0.5 Vdc Maximum (no load)
Maximum frequency	15 kHz
Max. operating current	20 mA at 1 kHz
Load	15 kΩ to both ground and supply
Peak reverse voltage	-15 Vdc continuous
Peak transient voltage	80 Vdc for 2 ms (max.)
Pulses per rev.	41 (LV/LC motor) 44 (KV/KC motor)

Shaft Torque

L and K Frame variable motors are available with splined, tapered, and straight-keyed shafts.

Shaft torque and spline lubrication

The rated torque is a measure of tooth wear and is the level at which a normal spline life of 2×10^9 shaft revolutions can be expected. The rated torque presumes a regularly maintained minimum level of lubrication via a moly-disulfide grease in order to reduce the coefficient of friction and to restrict the presence of oxygen at the spline interface. It is also assumed that the mating spline has a minimum hardness of Rc 55 and full spline depth. The rated torque is proportional to the minimum active spline length.

Maximum torque ratings are based on torsional fatigue strength considering 100,000 full load reversing cycles. However, a spline running in oil-flooded environment provides superior oxygen restriction in addition to contaminant flushing. The rated torque of a flooded spline can increase to that of the maximum published rating. A flooded spline would be indicative of a pump driven by a pump drive or plugged into an auxiliary pad of a pump.

Maintaining a spline engagement at least equal to the Pitch Diameter will also maximize spline life. Spline engagements of less than $\frac{3}{4}$ Pitch Diameter are subject to high contact stress and spline fretting.

Shaft torque for tapered shafts

The rated torque is based on the contact pressure between the shaft and hub surfaces with poor surface contact areas. With an increased quality of the contact areas, the contact pressure between the shaft and hub is increased and allows higher torque to be transmitted.

When a key is used for orientation of the hub on the shaft in conjunction with poor quality contact surfaces, the transmitted torque will drop significantly. This is due to the key carrying the torque, which limits the shaft torque carrying capability.

Maximum torque rating is based on an ideal contact area of 100 % and the retaining nut properly torqued. This allows for the highest contact pressure between the shaft and the hub.

Loop Flushing

K and L motors incorporate an optional integral loop flushing valve. Use the loop flushing valve in circuits requiring the removal of excessive contamination or installations that require the removal of additional fluid from the main hydraulic circuit due to cooling requirements.

K and L motors equipped with an integral loop flushing shuttle valve also include a loop flushing relief valve. The loop flushing relief valve poppet includes an orifice which controls flushing flow. Flushing flow of 5 to 8 L/min (1.5 - 2 gpm) is typical.

The opening pressure (indicated in graph below) of the loop flushing relief valve should be equal to or less than the charge pressure setting of the pump. Contact your Sauer-Danfoss representative for assistance.

Loop Flushing valve

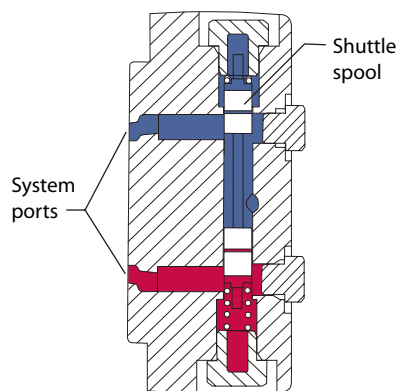

P106 493E

Relief valve

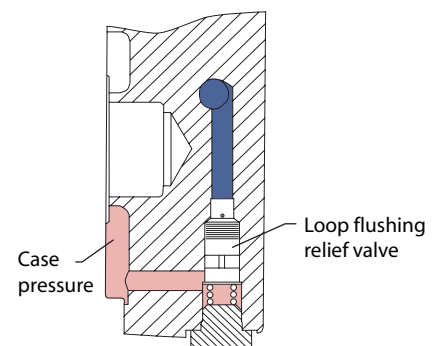

P106 494E

Loop flushing should not be used when using L/K motors in an open circuit configuration. Low loop/charge pressures will not be high enough to open the loop flushing relief valve.

**Loop Flushing
 (continued)**

Loop Flushing flow

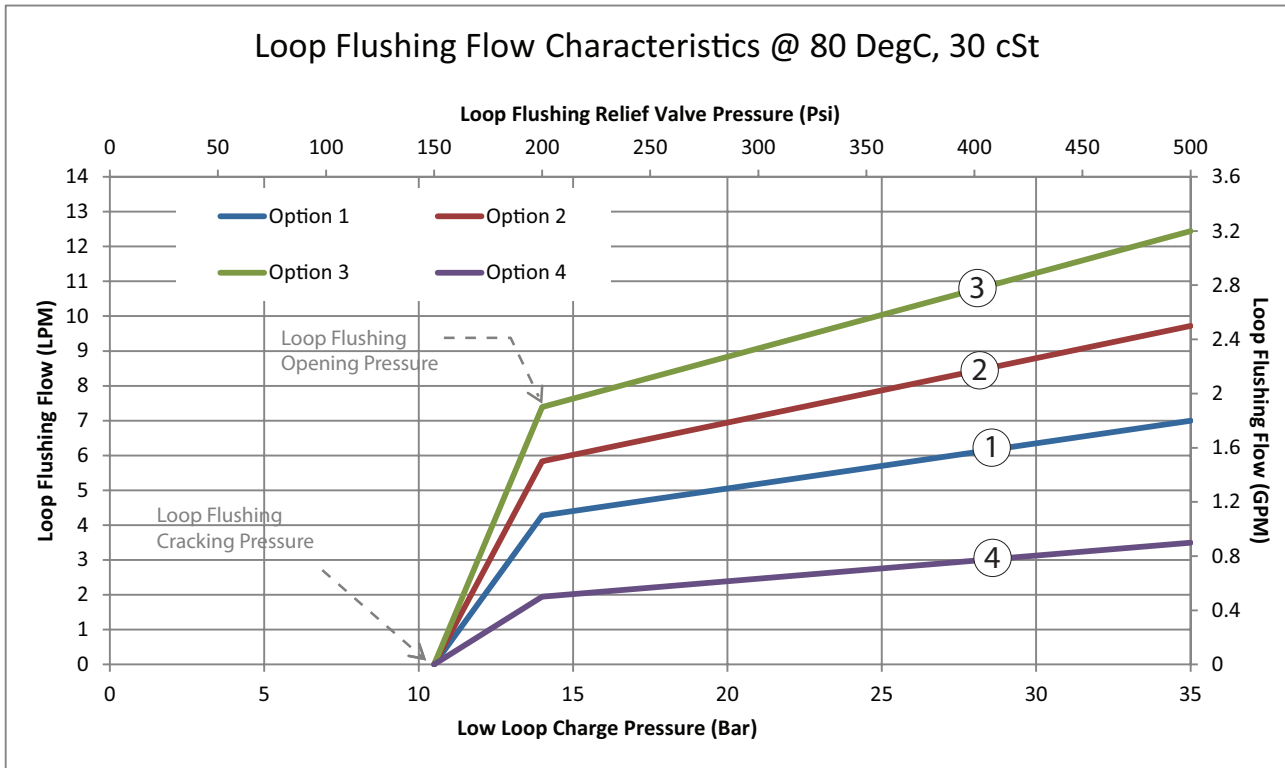

P108547E

Dust Seal Option

The dust seal option has been designed to increase the resistance to airborne particulates which could contaminate and potentially damage the motor output shaft seal. The speed rating of the dust seal is the same as the motor speed rating.

Available only with the tapered shaft option F.

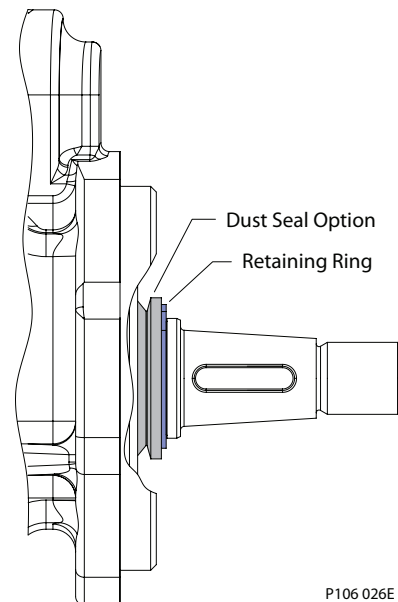

P106 026E

Output Shafts
 (continued)

Shaft options

Code	Description	Availability		Torque rating		Drawing
		LV/KV	LC/KC	Continuous N·m [lbf·in]	Maximum N·m [lbf·in]	
A	13 tooth spline 16/32 pitch ANSI B92.1 1970-Class 5	X	—	73 [650]	226 [2000]	
A	13 tooth spline 16/32 pitch ANSI B92.1 1970-Class 5	—	X	73 [650]	226 [2000]	
C	Ø 22.225 mm [0.875 in] Straight keyed (does not ship with key)	X	—	N/A	362 [3200]	

**Output Shafts
 (continued)**

Code	Description	Availability		Torque rating		Drawing
		LV/KV	LC/KC	Continuous N·m [lbf·in]	Maximum N·m [lbf·in]	
D	Ø 22.225 mm [0.875 in] 1:5 Taper (does not ship with key)	X	—	N/A	362 [3200]	<p>P104 168</p>
E	15 tooth spline 16/32 pitch ANSI B92.1 1970-Class 5	X	—	153 [1350] (Continuous torque rating based on spline tooth wear)	362 [3200]	<p>P104 170E</p>
E	15 tooth spline 16/32 pitch ANSI B92.1 1970-Class 5	—	X	153 [1350] (Continuous torque rating based on spline tooth wear)	362 [3200]	<p>P104 174E</p>

**Output Shafts
 (continued)**

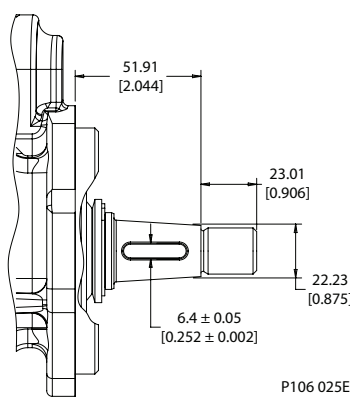
Code	Description	Availability		Torque rating		Drawing
		LV/KV	LC/KC	Continuous N·m [lbf·in]	Maximum N·m [lbf·in]	
F	Ø 22.225 mm [0.875 in] 1:5 Taper with Dust Seal Option (does not ship with key)	X	—	N/A	362 [3200]	 <p>P106 025E</p>

Displacement Limiters

L and K Frame variable motors can be equipped with optional fixed (non-adjustable) displacement limiters. Refer to *Maximum Angle/Displacement Setting*, for available displacement settings.

Motor Rotation

L and K Frame variable motors are fully bidirectional. The chart to the right gives the direction of rotation with respect to flow direction through the motor.

Rotation by flow direction

Mount	SAE-B	Cartridge
Flow A→B	CCW	CW
Flow B→A	CW	CCW

Controls

L and K Frame variable motors are designed to operate in two positions: maximum and minimum displacement. The motors are spring biased to maximum displacement and hydraulically shifted to minimum displacement. SAE-B mount motors can operate with a single or dual line control. Cartridge mount motors operate with a single line control only. Pressure applied at port X1 shifts the motor to minimum displacement. Pressure at X2 (dual line control) can assist the shift to maximum displacement. Refer to the table above for control input pressure range.

Control orificing

Cartridge and SAE mount motor controls rely on external valving and orificing to regulate shift speeds. You can achieve quick acceleration (shift to min) and slow deceleration (shift to max) simply by installing an orifice in the tank line of the external control valve.

SAE-B mount motors with single line controls can have optional, internal, supply and drain orifices installed to regulate control response times. Contact your Sauer-Danfoss representative for available orifice sizes.

Brake Release Port (cartridge motors)

Cartridge mount motors are equipped with a brake release port to allow access to the brake-release feature of the gear box from the rear of the motor. This consists of a simple passage through the motor housing with a rear-facing $\frac{7}{16}$ in. SAE O-ring boss port. To locate the port on the gear box, refer to the *Installation Drawings*. Applications using this brake release port require an O-ring to seal the passage against the gear box.

While all motors will have the brake release port, not all gearboxes are compatible with this motor feature. The rated pressure for the brake release port on the motor housing is 250 bar (this does take into account the O-ring interface between the motor and gearbox). Consult your gearbox manufacturer for suitability and compatibility. If your gearbox is not compatible with this feature, simply leave the port plugged.

SAE-B Mount (LV/KV)

Axial ports with loop flushing

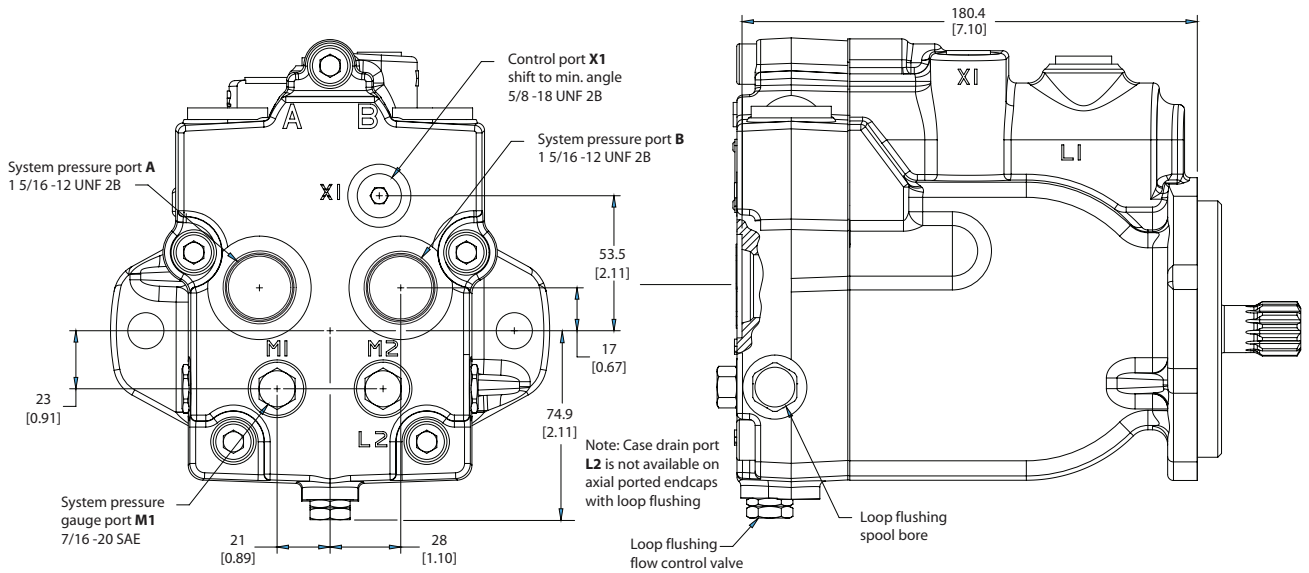

Axial ports without loop flushing

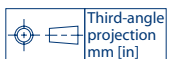
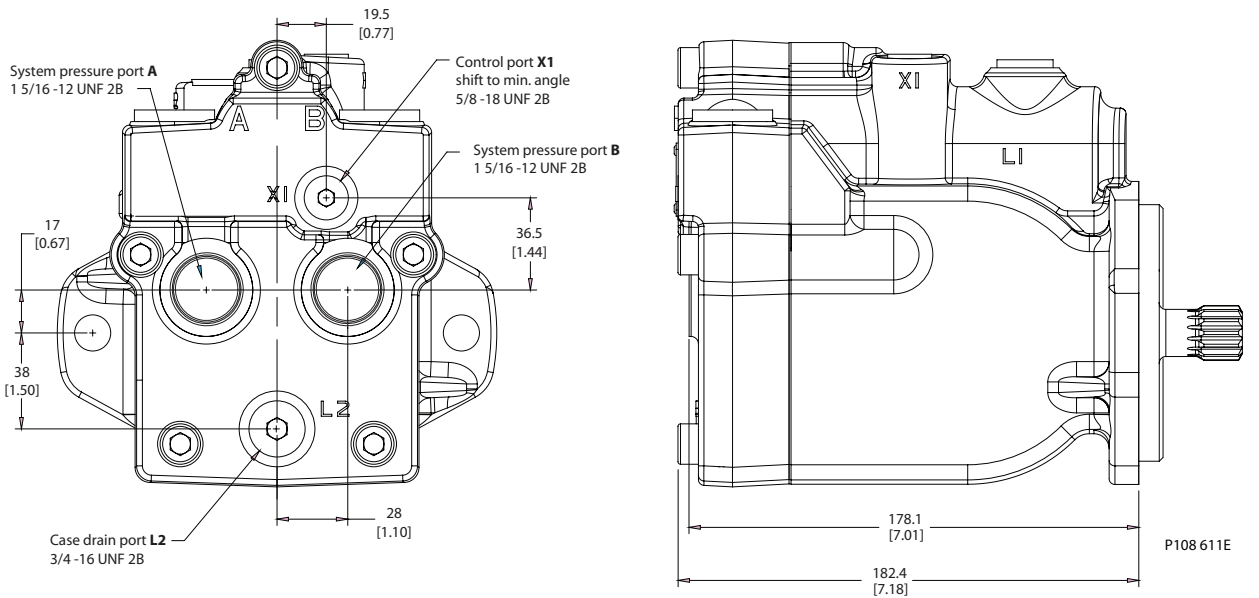

**SAE-B Mount (LV/KV)
 (continued)**

Radial ports without loop flushing

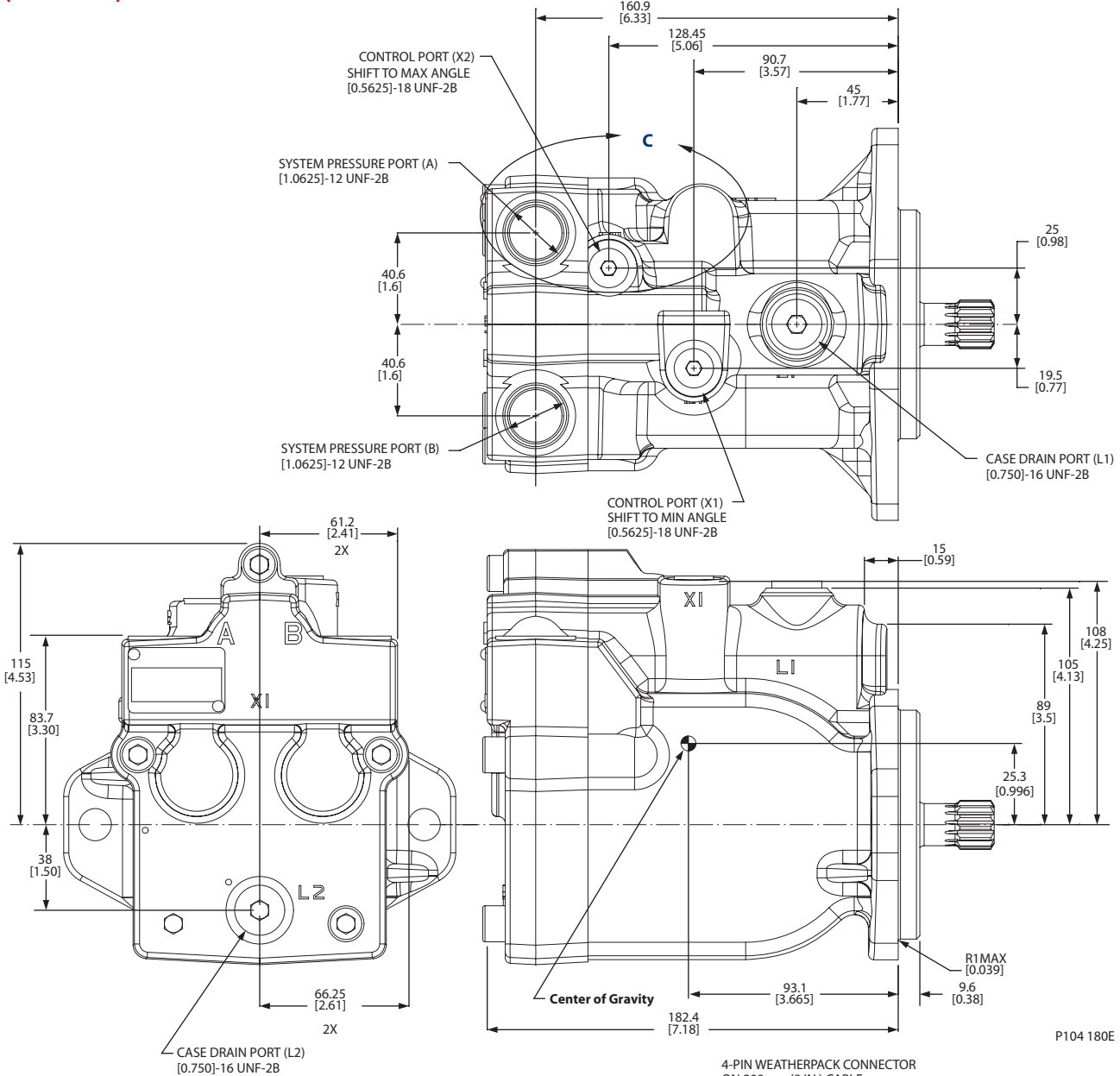

P104 180E

**VIEW C
 Motor with speed sensor**

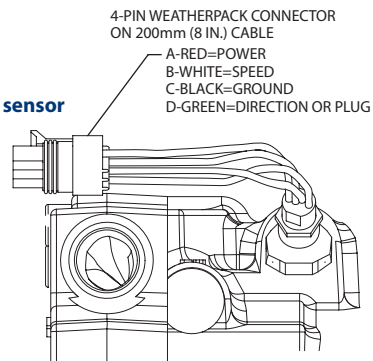

**SAE-B Mount (LV/KV)
 (continued)**

Radial ports with loop flushing

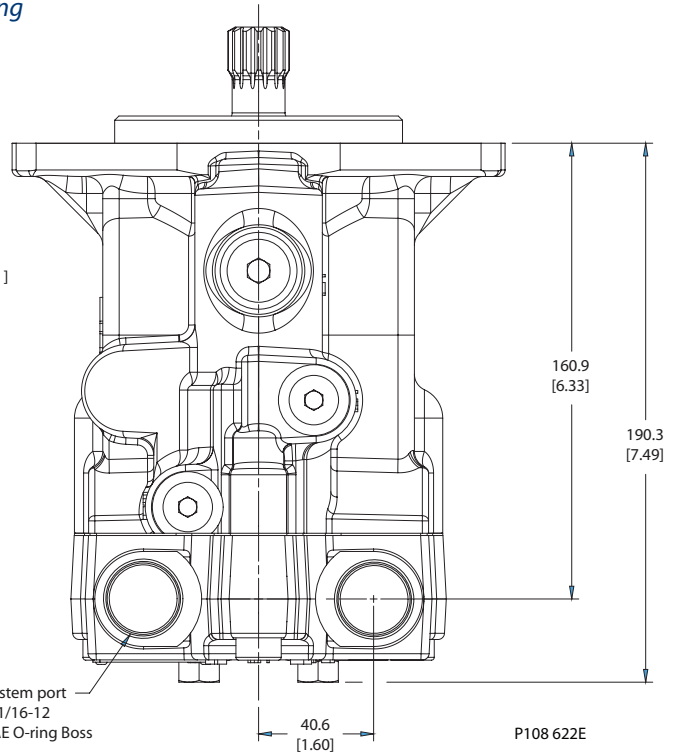
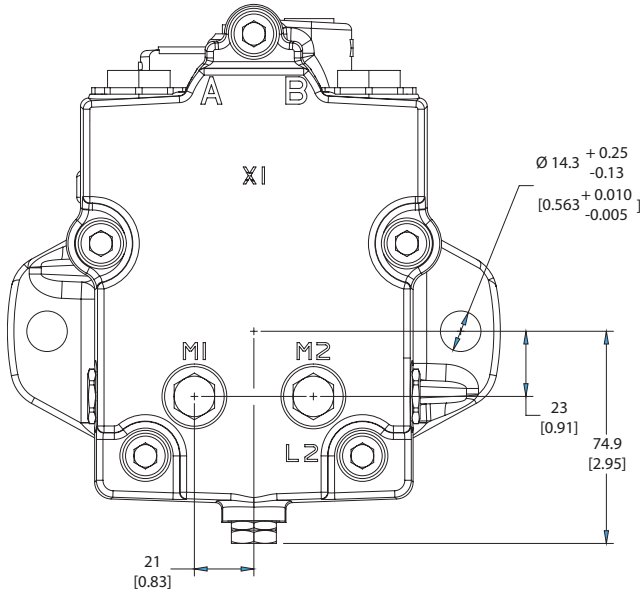

Recommended mounting hardware

Bolt size	Grade	Torque N•m [lbf•ft]
1/2 inch	5	86 [64]
	8	122 [90]

Use hardened washer under each bolt head.

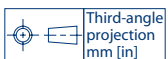
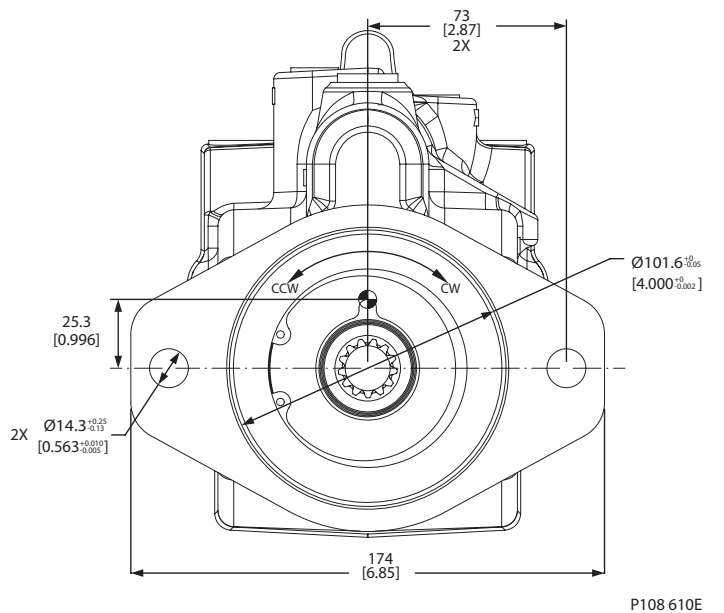

Cartridge (LC/KC)

Radial ports without loop flushing

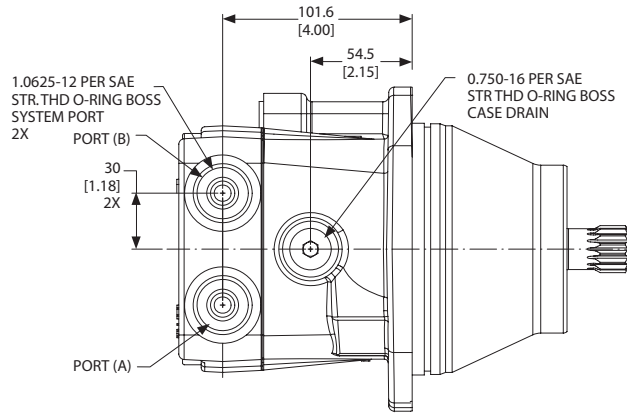
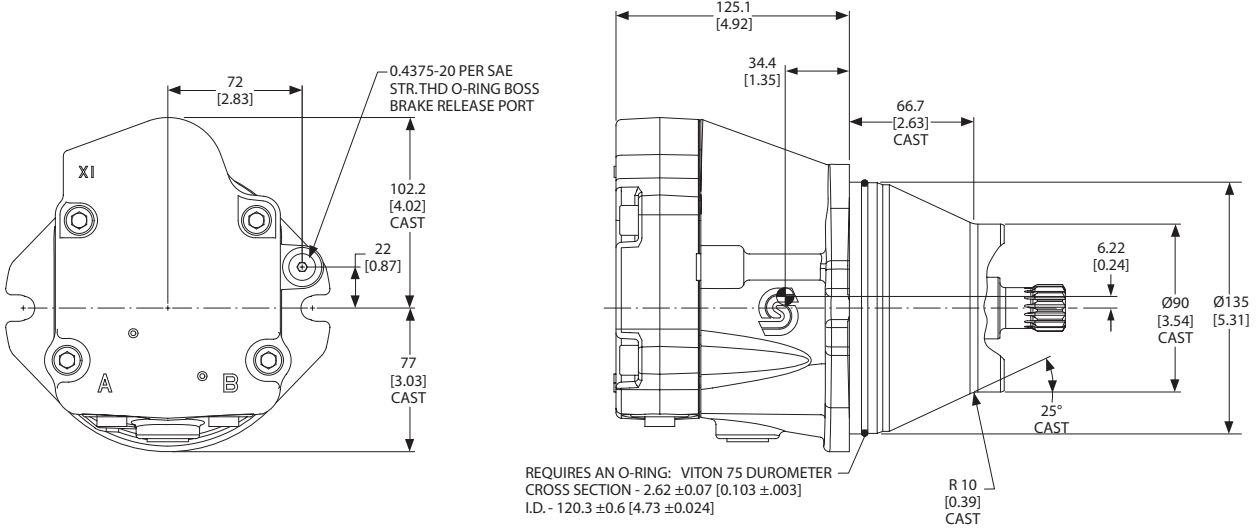

Radial ports with loop flushing

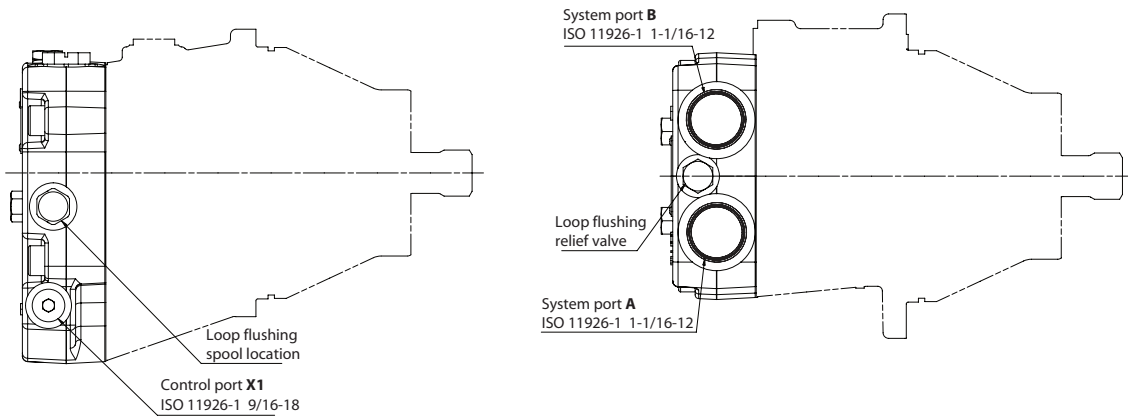

P104 183E



Cartridge (LC/KC)
(continued)

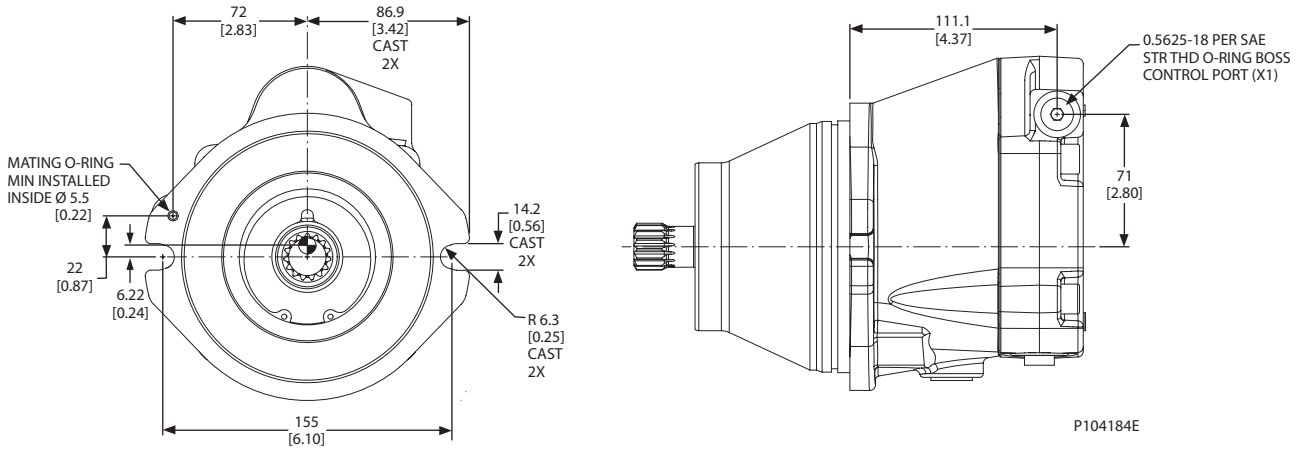

Recommended mounting hardware

Bolt size	Grade	Torque N•m [lbf•ft]	Mounting circle diameter
1/2 in.	5	86 [64]	160 mm [6.299 in]
	8	122 [90]	

Use hardened washer under each bolt head.

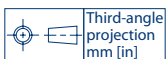



Products we offer:

- Bent Axis Motors
- Closed Circuit Axial Piston Pumps and Motors
- Displays
- Electrohydraulic Power Steering
- Electrohydraulics
- Hydraulic Power Steering
- Integrated Systems
- Joysticks and Control Handles
- Microcontrollers and Software
- Open Circuit Axial Piston Pumps
- Orbital Motors
- PLUS+1™ GUIDE
- Proportional Valves
- Sensors
- Steering
- Transit Mixer Drives

Members of the Sauer-Danfoss Group:

Comatrol

www.comatrol.com

Schwarzmueller-Inverter

www.schwarzmueller-inverter.com

Turolla

www.turollaocg.com

Hydro-Gear

www.hydro-gear.com

Sauer-Danfoss-Daikin

www.sauer-danfoss-daikin.com

Sauer-Danfoss is a global manufacturer and supplier of high-quality hydraulic and electronic components. We specialize in providing state-of-the-art technology and solutions that excel in the harsh operating conditions of the mobile off-highway market. Building on our extensive applications expertise, we work closely with our customers to ensure exceptional performance for a broad range of off-highway vehicles.

We help OEMs around the world speed up system development, reduce costs and bring vehicles to market faster.
Sauer-Danfoss – Your Strongest Partner in Mobile Hydraulics.

Go to www.sauer-danfoss.com for further product information.

Wherever off-highway vehicles are at work, so is Sauer-Danfoss.

We offer expert worldwide support for our customers, ensuring the best possible solutions for outstanding performance. And with an extensive network of Global Service Partners, we also provide comprehensive global service for all of our components.

Please contact the Sauer-Danfoss representative nearest you.

Local address:

Sauer-Danfoss (US) Company
2800 East 13th Street
Ames, IA 50010, USA
Phone: +1 515 239 6000
Fax: +1 515 239 6618

Sauer-Danfoss ApS
DK-6430 Nordborg, Denmark
Phone: +45 7488 4444
Fax: +45 7488 4400

Sauer-Danfoss GmbH & Co. OHG
Postfach 2460, D-24531 Neumünster
Krokamp 35, D-24539 Neumünster, Germany
Phone: +49 4321 871 0
Fax: +49 4321 871 122

Sauer-Danfoss-Daikin LTD.
Shin-Osaka TERASAKI 3rd Bldg. 6F
1-5-28 Nishimiyahara, Yodogawa-ku
Osaka 532-0004, Japan
Phone: +81 6 6395 6066
Fax: +81 6 6395 8585