

Cartridge valves

Function	Model Code	Maximum Working Pressure MPa	Rated Flow L/min											Page	
			10	20	50	100	200	500	1000	2000	5000				
(Flow, Directional Control) Flow Control Valves Directional Valves Check Valves Pilot Operated Check Valves	CVI	35						16	25	32	40	50	63	80	H1-1
	CVC	21													H2-1

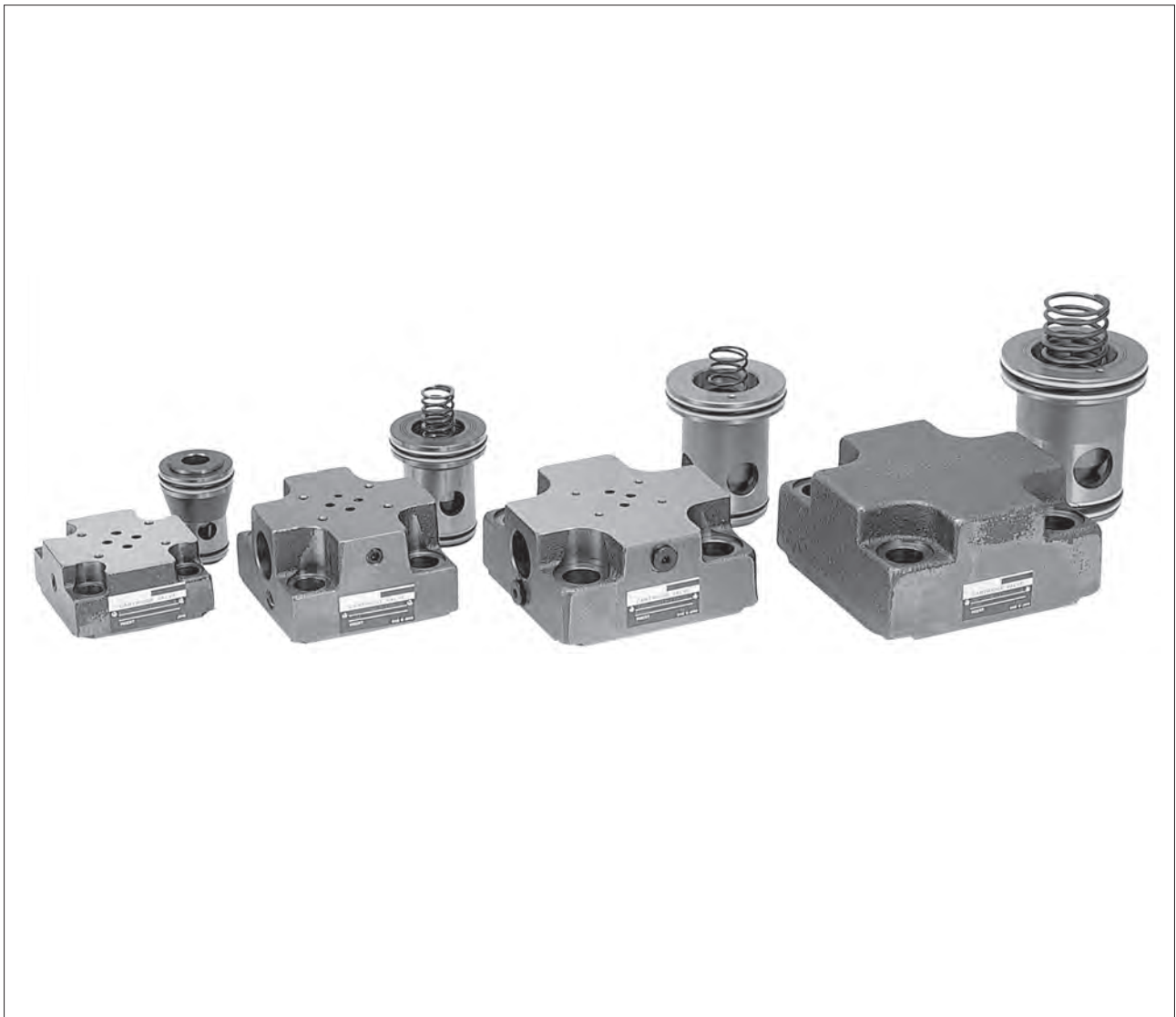

- Cartridge valves are composed of a combination of insert (main valve section) and various control covers to provide valve functions in a hydraulic circuit and can be incorporated in manifold blocks.
- Insert with check valve is controlled by pilot pressure to provide a combination of directional, flow, and pressure control.
- Valves come in seven sizes to match flow requirements.
- External dimensions of inserts which are fit into the manifold blocks are uniform. (ISO 7368)
- Hydraulic pilot control mechanisms are incorporated in covers to control spool movement. Additional functions such as solenoid switching valves, etc., can be stacked on top of applicable control covers.

Features of Cartridge Valve

Hydraulic Control Systems

- Poppet-seat configuration of main valve inserts reduces internal leakage compared to spool type valves and non-overlap design provides superior response.
- Cartridge valve systems consisting of inserts and control covers incorporated in manifold blocks reduce control circuit piping and saves space. This also means that there are fewer problems associated with piping such as oil leakage and vibration, factors which improve system reliability.
- One cartridge valve can provide a variety of control functions and it is possible to create a simple hydraulic system utilizing a minimum of cartridge valves to match system requirements.
- Besides enabling independent switch timing of individual flow paths, valve sizes and control functions can be selected to suit each flow path which enable shockless operation and enhances circuit efficiency.

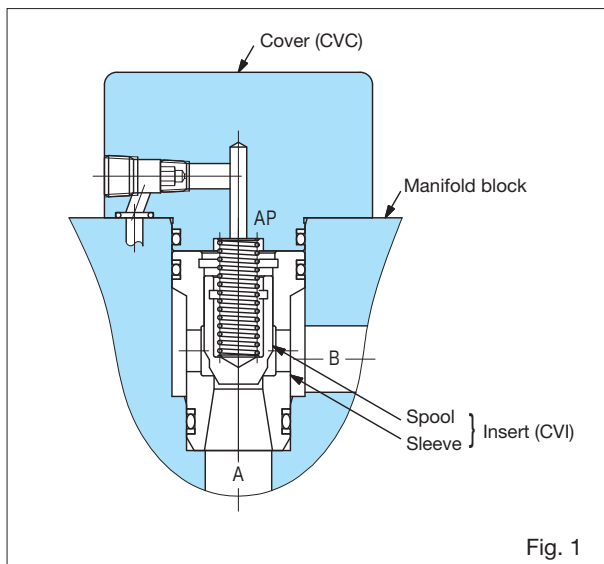

Fig. 1

Insert Operation and Types

- As Fig. 2 shows, pressure at port A and B act on the spool to move it in the open direction. Port A pressure, P_A , acts on the valve seat diameter circular area A_A . Port B pressure, P_B , acts on the concentric circular area, A_B , within the valve seat and spool diameters. Pilot pressure, P_{AP} , from the control cover acts on the top of the spool to close it. The area of pressure is the area of the spool diameter ($A_P = A_A + A_B$). Valve opening and closing is determined by the balance of these pressures, spring force F_s , and flow forces, F_i .

Therefore,

$$\frac{(P_{AP} \cdot A_{AP} + F_s)}{\text{valve closing force}} - \frac{(P_A \cdot A_A + P_B \cdot A_B + F_i)}{\text{valve opening force}} < 0: \text{valve open}$$

$$> 0: \text{valve close}$$

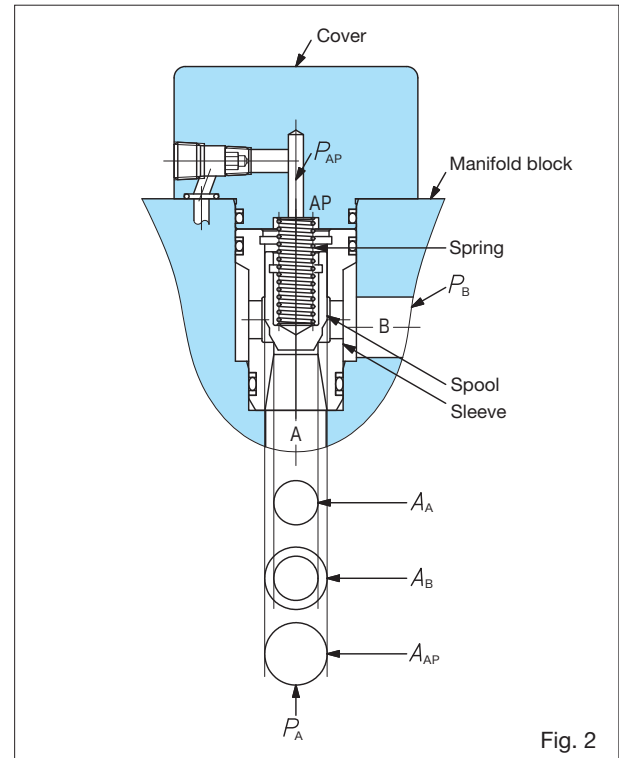

Fig. 2

- A_A and A_{AP} area ratios - 5 types as below.

Area Ratio $A_A : A_{AP}$	Function
1 : 2	Directional (flow) control
1 : 1.5	Directional (flow) control
(1 : 1.7)	(Normal open type)
1 : 1.1	Directional control or pressure control
1 : 1	Pressure control

- Spools with area ratios 1:2 and 1:1.5 are notched (throttled spool ends). Besides use in flow control they are used to reduce shock during valve opening and closing.

Control Cover Types

(for Direction and Flow Control)

- A variety of covers are available to meet system requirements. In addition to covering the cartridge inserts, they control pilot pressure to the AP section of the inserts and integrate functions to adjust and control spool opening.
- Pilot pressure can be switched by selecting cover for stackable directional valve.
- Replaceable internal orifice plugs allow opening and closing speed adjustments of main valve (insert).

Pressure Control Cartridge Valve

- Relief function inserts and covers are available for sizes 16, 25, and 40 and reducing function for size 25. Consult Tokyo Keiki regarding specifications, dimensions and other details.