

ZE' SOLUTION™ SAPELEM

Handle your products intuitively



Intelligent
Powerful
Precise
Secure
Fast

SAPELEM
handling and process



A few words about SAPELEM

For half a century, **SAPELEM handling and process** has been designing, managing, and installing material-handling systems that are at the heart of companies' processes.

As a long-time pioneer, SAPELEM handling and process, invented the **RGO CONCEPTION** to design products that always combine **health** and **safety** with **profitability**

The latest invention, **SAPELEM ZE' SOLUTION™** is at the top of worldwide high technology.

It is the best system to match the repository OHSAS 18001.

Because every case is unique, SAPELEM handling and process and its registered partners are committed to proposing onsite **turnkey solutions**.

We advise in determining the best solution corresponding to your needs, environment, and pace. We design and install the system, train your operators and maintain the capabilities of your installations.

Because a test is worth a thousand documentations, come and discover **ZE' SOLUTION™** : try it out. You won't go wrong!



Pascal DENOEL
Chairman



New offices with High Quality Environmental standards

CONTENTS

ZE' SOLUTION™ SAPELEM

Introducing ZE' SOLUTION™ SAPELEM

Handle your products intuitively	p.1
The system can adapt	p.3
A combination of high technology	p.4

Control handle ZE' Joystick Zii™..... p.6

It does all of your fingertips !	p.7
So easy to forget it !	p.9
Fundamentally convenient !	p.11
Accessories that make the difference !	p.13
Specifications	p.14

Electronic lifting system ZE' Lift ELS™ p.16

The loads are not heavy any more !	p.17
The intelligence service of profitability !	p.19
Fully secure power !	p.21
Specifications	p.23

Multi-articulated aluminium arm ZE' Arm R2a™ p.24

The slight frames that beat all the heavyweights !	p.25
Move effortlessly !	p.27
Specifications	p.29

Your Orchestra Conductor ZE' Soft™ p.30

ZE' Soft facilitates all !	p.31
ZE' Soft protects all !	p.33
ZE' Soft helps you with all !	p.35
ZE' Soft takes care of all !	p.37

PACKS ZE' SOLUTION™ SAPELEM p.38

REFERENCES ZE' SOLUTION™ SAPELEM p.40

ZE' SOLUTION™ SAPELEM

Handle your products intuitively

INTERNATIONAL
PATENTS

INNOVATION
AWARDS

Health

Effortless
Ergonomic
Fits the load immediately

Intuitive

Easy
No training required
Responsive to manual control

Smart

Customizable
Management software
Assists the operator
Bluetooth communication

Profitability

Protects the product
Most responsive system
Fastest system
Respectful to environment

Safety

Integrated ABS and ESP
Load control
Presence detector
Compensates for errors
Lifting / Removal authorization

Certified

CE certification
According to the standards EN12100,
EN60204, EN14238, EN1005, NIOSH,
OH SAS 18100

High-performance

Built-in calculator, aluminium, Oled screen
Combination of reliable high technologies
20 years worth of man-hour research and development



www.ze-solution.com

non-contractual data

ZE' SOLUTION™ SAPELEM

Handle your products intuitively

Smart technologies at everyone's service !

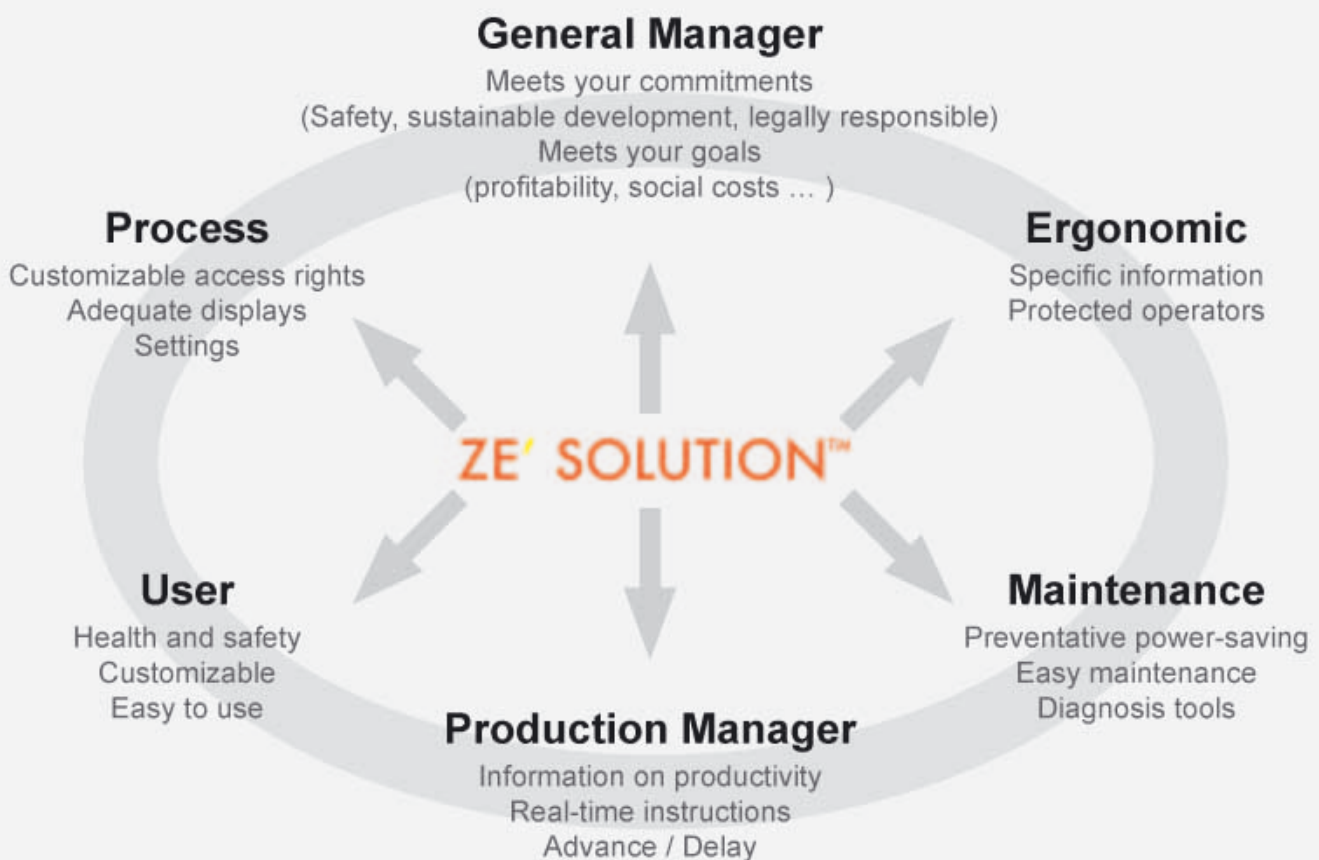

OPINION OF USER : Ms. ROBERTY, operator, food industry

" ... It has been a while since we had asked management to have equipment to help handling of condiment tins. After 15 years with the company, I admit having had more and more physical ailments due to repetitive movements with heavy weights. I had already been on sick-leave twice due to lumbago and tendonitis.

A study was done and ZE' SOLUTION™ SAPELEM with grippers was retained. It changed our whole approach to the work. With my colleagues, we are much more motivated, and it is really easy. "

The system that knows how to adapt !

Regardless what your products may be

The system is designed to lift all types of loads :

SIZES : small, large (to several m²)

SHAPES : simple or complex, sheets, cylinders, spheres, narrow or wide ...

WEIGHT : up to 300 Kg (660 lbs)

STATE : soft, rigid, porous, hot, cold ...

MATERIALS : plastic, glass, steel, ceramic, cardboard, wood, composite, concrete ...

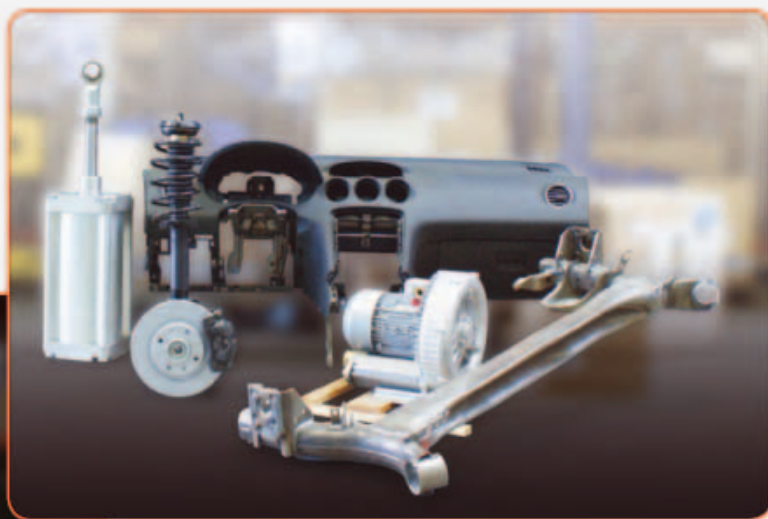

PRODUCTS : Cans, boxes, bags, doors, windshields, bumpers, tanks, tubes, bottles, pallets, tyres, ham, spools, eggs, motor parts (water pump, etc.), metallic systems, windows, dashboards, sand core, equipments, moulds, parts of fuselage, yoghurt pots, exhaust system, car batteries, shower trays, sinks, sunroofs, motorbikes engines, bus windscreen, car doors, bonnets, steel cabinets, car seats, aeronautical parts ...

Used in all fields

The simplicity of ZE' SOLUTION™ SAPELEM allows various configurations. The system can be just as easily used in an SME or a large industrial site, in the heart of the production or logistics.



Food industry, aeronautics, car industry, textile, cardboard, glass, woodworking, plastic, chemistry, sheet metal, medical, warehouses, electronics, equipments, pharmacy ...



ZE' SOLUTION™ SAPELEM

A combination of high technology

1 ZE' Joystick Zii™+ 2 ZE' Lift ELS™+ 3 ZE' Arm R2a™+ 4 ZE' Soft™

ZE' SOLUTION™



2

Electronic lifting system ZE' Lift ELS™ (p.16)

Provides dynamics and lifting capacity.
Acceleration of up to 1 g for 2 m/s max.
Up to 300 kg.



Also exists
under rail

Just try it !

Test it, you will understand it !

3

Multi-articulated aluminium arm ZE' Arm R2a™ (p.24)

Ensures effortless horizontal movements.
Ranging up to 4.7 m.

1

Control handle ZE' Joystick Zii™ (p.6)

Detects movements of the hand.
Felt from 20 g at fingertips.

4

Built-on software ZE' Soft™ (p.30)

Commands and controls the system.
Communicates and manages the parameters.

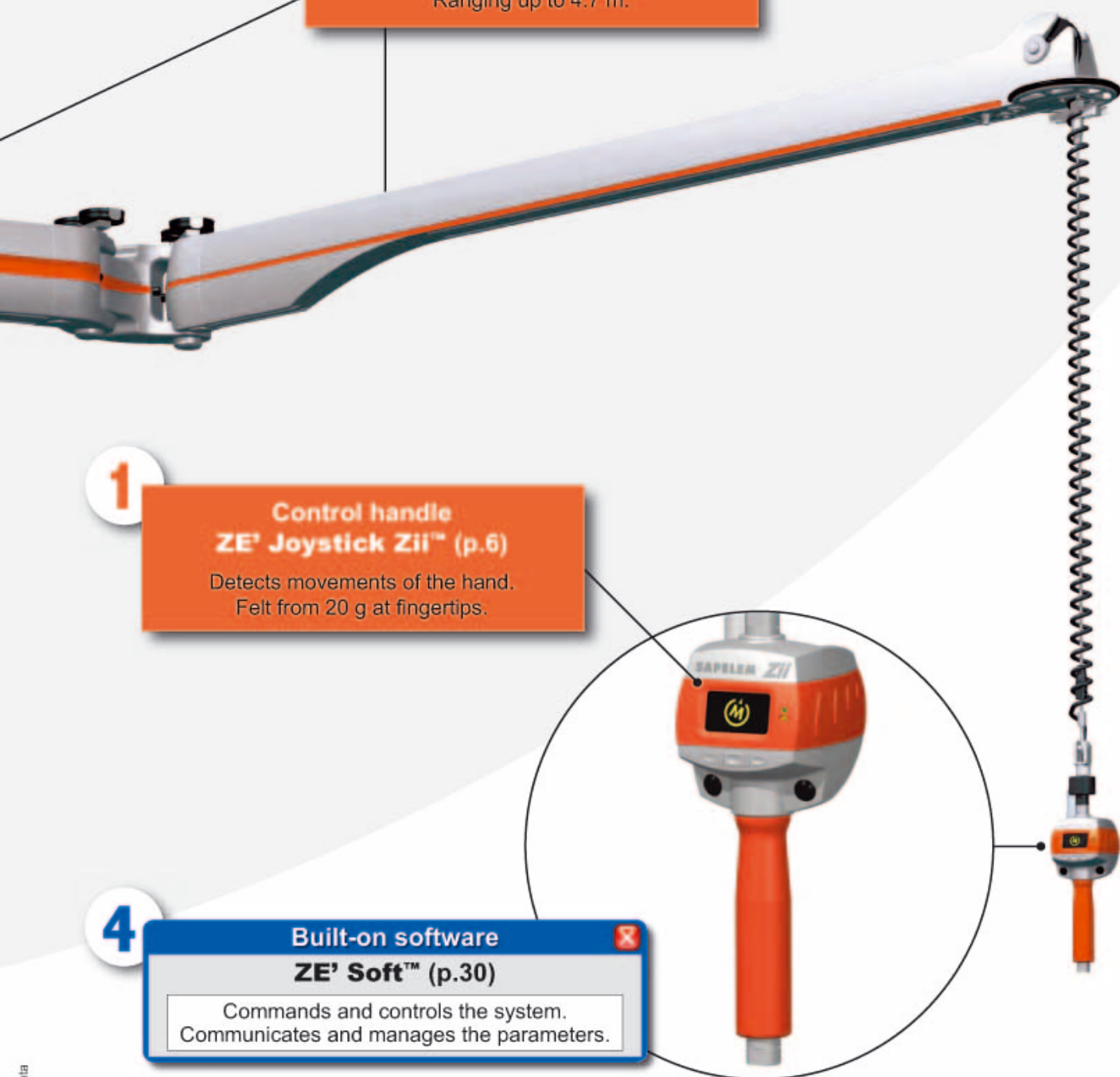

Control handle

ZE' Joystick Zii™

Z-axis Integrated Intelligence

Communicative

Inputs and outputs 24V locally available
Graphic screen and keyboard settings
Possible extensions by industrial bus
Bluetooth

Ergonomics

Minimum size for maximum visibility
For the right and left-handed

Secure

Conditioned lifting and releasing
Presence detector
Access rights



Intuitive

Preserves the natural feel for the operator
No button to press for movement
Active from 20 g

Strong

Anti-shock hull and protective strip
Resists aggressive environments
Protected Inputs / Outputs
No maintenance needed
Patented sensors

PATENTED

Light

Weight : 1,9 kg

It does all of your fingertips !

Simple usage

The ZE' Joystick Zii™ control handle possesses the necessary command buttons.

Reduced to the essence, it has :

- 2 grip / release buttons of the load (for the right and left-handed)
- 3 buttons to communicate with the software ZE' Soft™
- 1 graphic screen for instructions and communication
- 1 control light, up / down authorization
- 1 control light, load release authorization

health

.....

safety

.....

profitability

.....



Intuitiveness and speed of movement

For the device to seem transparent, it must react instantaneously and without explicit actions.

Ultra Fast, it reacts to the thousandth of a second with the operator's commands. Moving the load becomes as quick and easy as the natural pace, which was not the case with pre-existing solutions.

- ▶ Result, the operator does not need to compensate the late reaction of the system by forcing more than necessary. The operator is, therefore, protected against MSD (Musculoskeletal Disorder).

All that is required is to hold the handle, and load follows the movements of the operator's hand upwards or downwards.

- ▶ Result, the vertical movements are not delayed, neither by the use of the triggers nor the pushbuttons. The risks of tendonitis and carpal tunnel injuries are reduced to the maximum.

Sensitive, 20 grams are sufficient to initiate the movement. To control action, the operator has to keep minimum feel.

The handle has an integrated **force feedback** which allows the operator not to completely lose feel.

health

.....

safety

...

profitability

.....



Control handle

ZE' Joystick Zii™

Z-axis Integrated Intelligence

Communicative

The commands of the operator are transmitted instantaneously by industrial bus (CAN) system lifting ZE' Lift ELS™.

The handle has 5 connectors and 1 industrial CAN bus, which allow for increased pilot functions (Sensors and/or actuators of the lifting device, slave handle control ...).

▶ Result, it controls and commands the functions of the lifting device with ZE' Soft™.

It can also communicate with the environment to send and receive via Bluetooth, or information management cables, programmes, statistics ...

The diameter of the helix cable serving the communication between the handle and the ELS is reduced to maximum.

▶ Result, the operator has the largest field of vision possible.

health ...

safety •

profitability

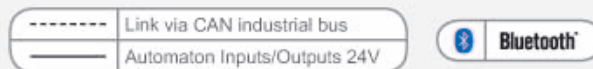

The helix cable allows the communication between the ELS and the control handle, as well as the low energy passage powering the gripper.

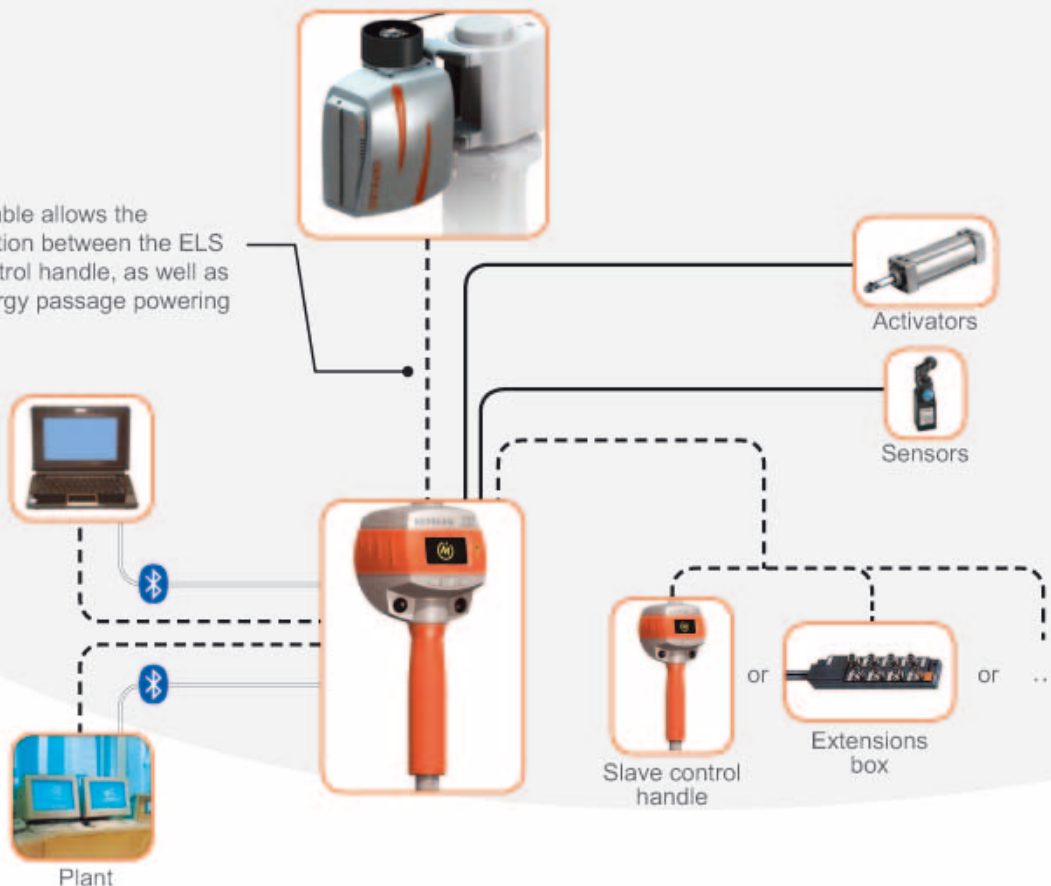

So easy to forget it !

Strong

The used materials are reinforced, and the screen protected.

Inputs / Outputs are protected against short circuits, reversions of polarity, overloads.

Electronics and sensors are without contact with the mechanics.

▶ Result, no wear.

PATENTED

health

safety ..

profitability

Accuracy a given

The control handle ZE' Joystick Zii™ combined with ZE' Lift ELS™ electronic lifting system eliminates the effects of pumping and vibrations.

▶ Result, the load is handled in safety with accuracy less than a millimetre.

health ...

safety

profitability



Adapted length of the control handle

In certain cases, such as important vertical strokes, it is recommended to use a control handle with an adapted length.

The control handle ZE' Joystick Zii™ improves the ergonomics by offering 5 adapted standard lengths : 140, 300, 500, 700, and 900 mm.

These different lengths allow for ensuring a comfortable position for the user. As such, regardless what action may be, the hands of the user can remain within the space of the ergonomic recommendations.

health

safety .

profitability ..



OPINION OF EXPERT : Ms. BOURGET, trainer in gesture and position

" Handling loads, when unassisted, can cause several pathological risks.

With the different lengths of handles provides by ZE' SOLUTION™ SAPELEM, the body remains straight. The operator goes with the load and handles it to its final destination, and prevents movements in areas too low and too high. "



www.ze-solution.com

Control handle ZE' Joystick Zii™ Z-axis Integrated Intelligence

Efficient ergonomic interfaces

The control handle is ergonomic. It has been designed to fit the operator's hand perfectly.

To release the load, two pushbuttons are ideally placed on each side of the handle: One for the right-handed; the other for the left-handed.

- ▶ Result, wrong moves and tendonitis are prevented, and actions are faster.

The screen is graphic, of large dimensions, luminous with strong contrast, and inclined towards the eyes of the operators.

- ▶ Result, the interface is always of excellent quality, regardless the angle of the view or the brightness. Thus, reading is quick.

The hand presence detector, without contact, saves the operator forceful triggering.

- ▶ Result, decrease of MSD (Musculoskeletal Disorder) risk.



health

.....

safety

..

profitability

...

Safety at all levels

The control handle ZE' Joystick Zii™ enables compliance with safety standards. It has numerous advantages that make it a great tool for security and reliability, while remaining user-friendly.



" Hand presence " : a photoelectric cell detects the presence of operators' hands. In absence of the hand, ascent or descent movements of the load are blocked.

- ▶ Result, undesired movement is impossible.

Elimination of pinching risks.

Removal of sharp edges and bulging out.

health

...

safety

.....

profitability

...

Fundamentally convenient !

Integration of control handle

The control handle ZE' Joystick Zii™ is equipped with mechanical interfaces that can fit low and high levels.

- ▶ Result, it integrates easily and quickly into all the configurations, depending on the type of setting, type of gripper, and a large number of accessories.

Setting types : Under cable
Off-centre
Multiple (Slave-control)

Gripper types : Fits all types of grippers
Simple or complex
Controls the actuators
Perceives its sensors

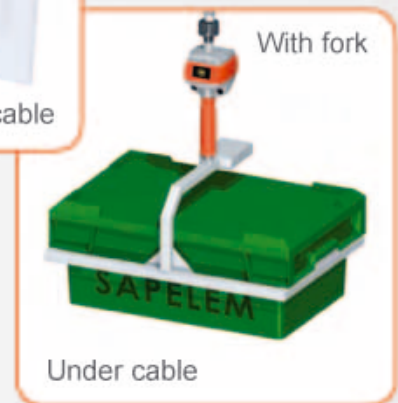

→ Please contact us for standard or special grippers.

health

....

safety

.

profitability

.....



Control handle

ZE' Joystick Zii™

Z-axis Integrated Intelligence

Accessories

To meet your needs more closely, the control handle provides a multitude of accessories.

Connections :

For your connections, SAPELEM offers you a full range of certified connectors and cables.

- ▶ Result, saving on integration time, an assurance of success and reliability.



health

•

safety

•••

profitability

••••

Additional protection :

certain environments, usage or attitudes of the user (concentration, vigilance, disturbance ...), collision risks can be very serious

This accessory protects the hand of the operator and the control handle.

- ▶ Result, decrease the risk of accidents.



health

•••

safety

•••••

profitability

••••

Fast change of tools :

Handling different loads may require several tools. This accessory allows for simple pressure on the trigger to change the gripper without tools.

- ▶ Result, changing the tool is done simply and quickly. The adapted tool is constantly at the operator's disposal.

The tools are lighter and more ergonomic, while being simpler and less expensive.

Safety is integrated: The system is locked if the load is not put down.



health

•••••

safety

••••

profitability

•••••

Accessories that make the difference !

Personalization of display :

You can display on the screen of the control handle your logo and multiple many, statistics, contractual information and much more.

- ▶ Result, pertinent information or necessary instructions to carry out work are constantly at the operator's disposal, improved productivity of the operator.



health ...

safety •

profitability

Sound :

The sound is a very good ergonomic complement for assisting the operator's perception of situations. Example: BEEP to approve lifting or releasing.

- ▶ Result, no wasting of time.

In the case of using a gripper of vacuum suction, the sound is required to act as an alarm.

- ▶ Result, the operator will be notified of a lower vacuum level.



health

safety

profitability

⚠ This accessory must be provided upon order.

Load Cell :

For example, it will allow the operator to quantify emptying a canister with precision, or the amount of substance in a container.

Incidentally, this accessory allows for moving the load without the control handle, namely " constant mass " .



health •

safety •

profitability ..

➔ Please contact us for all other accessories and special cases, including additional buttons ...

➔ Please refer to the SAPELEM Components brochure for a selection of suction pads, vacuum generators, vacuum switches, and other accessories.



Control handle

ZE' Joystick Zii™

Z-axis Integrated Intelligence

Oled graphic display, protected by multi-carbonate screen

Shell loaded in fibreglass

Rubber protection strip

SAPELEM Zii

LED (Light-emitting diode)
lifting authorization
release authorization

3 button setup dropdown menus

watertight grip / release button for right-handed

watertight grip / release button for left-handed

Protection rating against solid and liquid objects

Control handle tested according to EN 60 529.
- IP 40 Standard
- IP 42 Optional

Protection rating against mechanical shocks

Control handle tested, screen included, IK 05 according to EN 50 102.

Flammability rating

Self-extinguishing plastic handle classified UL 94-V0

Specifications

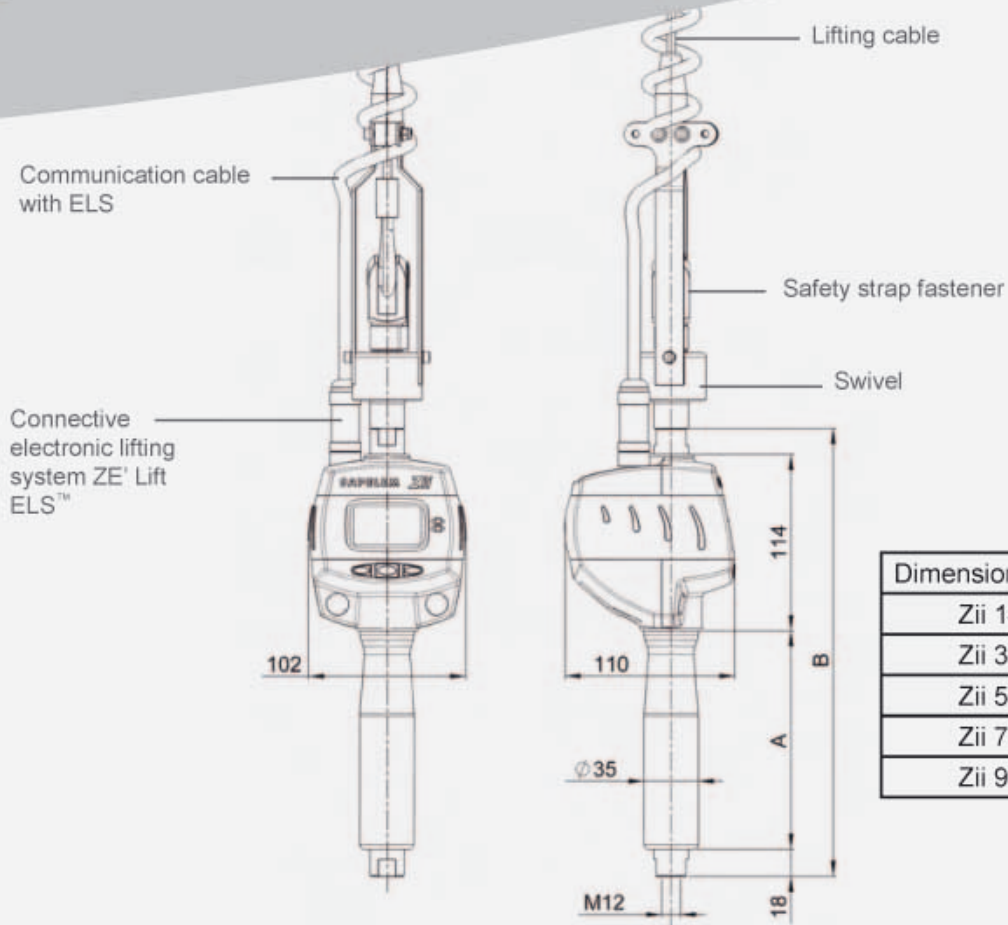

Dimensions (mm)	A	B
Zii 140	140	290
Zii 300	300	450
Zii 500	500	650
Zii 700	700	850
Zii 900	900	1050

Available connections

- 4 inputs 24V
- 4 outputs 24V for solenoid valves
- 1 analogical input
- 1 CAN bus connection

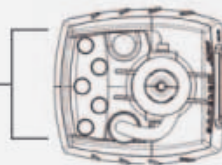

⚠ Inputs / Outputs must be specified at ordering (see page 41).

Empty weight
1,9kg

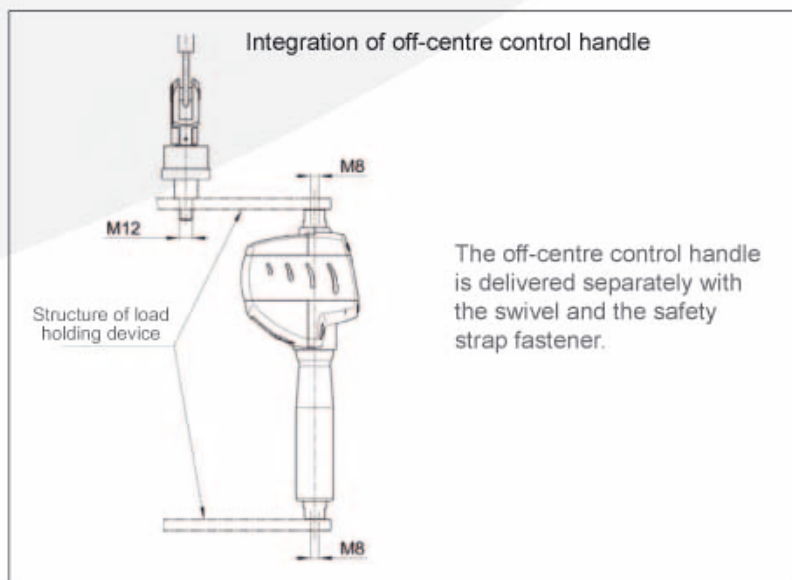

Electronic Lifting System **ZE' Lift ELS™**

Smart

Variable loads without adjusting
Measure and memorize
Communicative

Multipurpose

Setting up according to different supports
Multi energy

Dynamic

Reactive : acceleration up to 1g
Fast : speed up to 2m/s

Safety

Controlled deceleration
Manages energy cuts
Self-protected
Built-on brake
Steel cable



Compliant

Precise : Position less than a millimetre
Reactive : Net stop without delay
Reproducible

Economical

Easy maintenance
No training required

The loads are not heavy any more !

Wide range

Range of 5 ELS : 50, 80, 130, 200, 300 kg.

This layering makes it possible to reconcile contradictory performance: Speed, acceleration, weight variables, precision, and reactivity.

- ▶ Result, ZE' SOLUTION™ adjusts itself to the expected performance particular to each ergonomic handling.

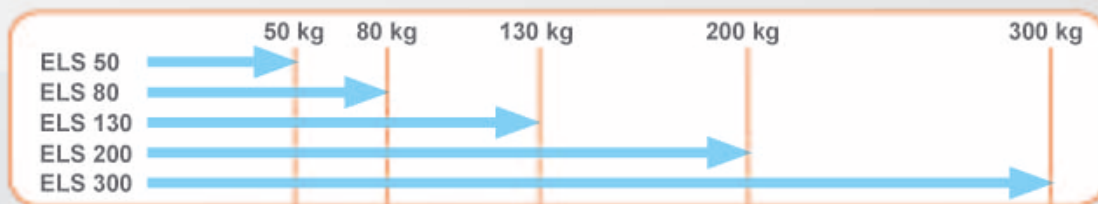

Notable feature: Performance is preserved even in intensive use during the peak capacity of each device.

health

safety

profitability

Dynamic

With an actual speed of 2 m/s, ZE' Lift ELS™ is the fastest lifting system of the market.

This effective speed, thanks to an acceleration of 1 g, allows reaching the maximum speed in 0.2 of a second. Without such responsiveness, the high speed proposed by the system would have never really been attained and had no interest.

Joined with the control handle ZE' Joystick Zii™, the load follows the natural movements of the operator's hand, and without making any effort.

- ▶ Result, the operator does not need to force more than necessary to compensate for a slow-responsive system. Decrease of MSD and lumbagos.

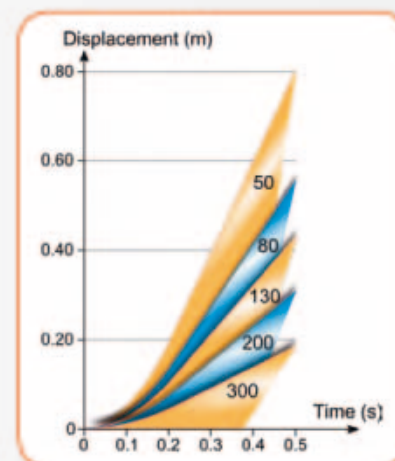
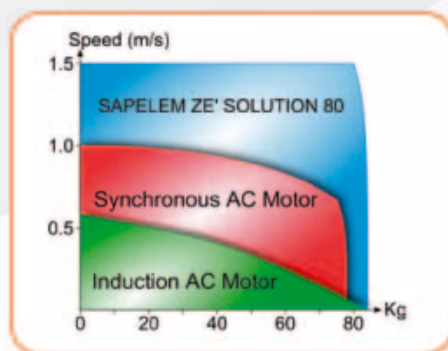

health

safety

profitability



Electronic Lifting System ZE' Lift ELS™

Smart

The electronic lifting system ZE' Lift ELS™ constantly measures torque, speed, position, energy, temperature

ZE' Lift ELS™ stores at any moment all of these parameters, and many others. Thus, even in case of power failure, the system restarts where there was no change in position of the load.

- ▶ Result, no complex setup, procedures or long start-ups are needed. The environment, the product and the operator are all protected.

ZE' Lift ELS™ automatically adjusts to load variations. This variation is continuous (filling/emptying of can for example), or sudden (loss of component, removal).

- ▶ Result, no adjustment is necessary, neither at start up nor during the process.

ZE' Lift ELS™ also communicates in real time with ZE' Joystick Zii™ control handle to provide ZE' Soft™ all the information necessary to operate the system and receive the orders of the movements to be performed.

ZE' Lift ELS™ can also be connected to the plant by industrial bus (CAN) to synchronize with other processes.

health ...

safety

profitability

Economical

Energy

ZE' Lift ELS™ consumes energy only when it is used.

No maintenance required

The gearbox is lubricated for life.

Increased lifetime of wear parts

The self-centered communication cable reduces friction on the lift cable. Its lifetime is increased.

Interventions are simplified

The change of the lift cable is controlled by a special function of ZE' Soft™ activated from the control handle ZE' Joystick Zii™.

- ▶ Result, the operation is simple and quick.

The opening of the hull into two parts facilitates access for electrical connections. Its hinge maintains the open part.

- ▶ Result, no risk of falling.

The possible change of the communication cable is done simply by unscrewing an external connector, without having to open the hull.

- ▶ Result, it is simple, fast, and requires no special skills.



health ..

safety ...

profitability

The intelligence service of profitability !

Multipurpose

Multi-energy

ZE' Lift ELS™ can provide the gripper the 3 main types of energy : electric power in addition to the low-voltage supply systems, pneumatic, and vacuum.

▶ Result, your grippers are designed to suit your needs and energy constraints.

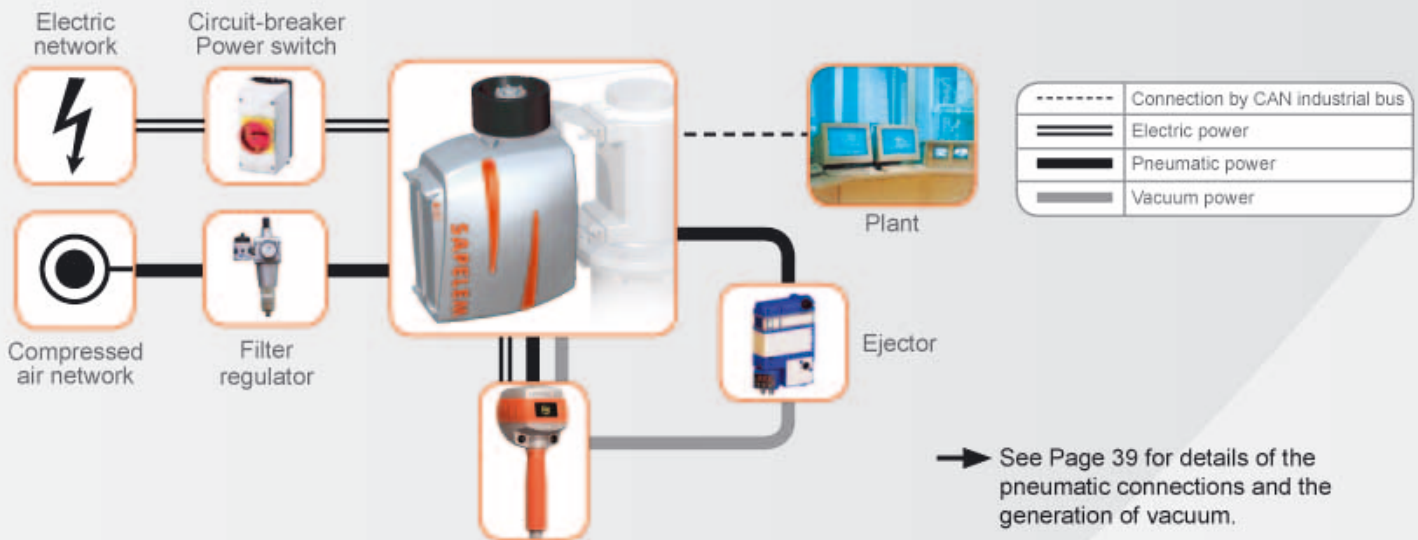

➔ See Page 39 for details of the pneumatic connections and the generation of vacuum.

health safety . profitability

Setup configurations

Each model fits naturally ZE' Arm R2a™, mobile under rail, or mobile under gallows.

▶ Result, you can choose the type of structure best suited to your environment, you application, or budget.



Electronic Lifting System ZE' Lift ELS™

Safety at every level

Safety aims to cope with all situations and intervenes at all levels.

- ▶ Result, the operator, the handled product and the load-bearing structures are protected.

Stable by default

The electronic lifting system ZE' Lift ELS™ is stable by construction.

- ▶ Result, in the absence of operator action, the load does not move, as opposed to other systems that are unstable by default and are thus, dangerous.

In case of power failure

A tight mechanical brake, integrated into the motor, starts automatically.

- ▶ Result, the load is held in position even in a more difficult environment (oily, wet).

In case of unintended drop of load

Powerful due to its intelligence and reaction time, ZE' Lift ELS™ reacts immediately to allow the handle ZE' Joystick Zii™ and its gripper in position.

- ▶ Result, no risk of abrupt rising which could seriously injure the operator.

Controlled deceleration

In case of deactivation of " hand presence " or unanticipated unknowns, the actual intelligence of ZE' Lift ELS™ decelerates in an appropriate way to a complete stop of the load.

- ▶ Result, no sudden stop and thus no shocks that could lead to falling of load or damaging your facilities (rails, arm, bracket, structure, gripper).

In case of overload

ZE' Lift ELS™ is protected in temperature and load. Combined with ZE' Soft™, the lifting of a load exceeding the maximum load capacity is denied.

Lift cable

The lift cable is in ultra-flexible steel. It is designed with a safety coefficient of at least 5 (EN 14238).

The clip of the lifting cable is protected by a minimum winding of 3 round turns on the drum.

health •

safety •••••

profitability •••



THE ADVICE OF SAPELEM : Electric, it is sustainable development

" The choice of electric power is the assurance of great reliability. The electric solution SAPELEM allows power to easily manage a very high precision of movement, and an optimised safety. The power allows for many features.

This gives a better overall performance than the use of a balancer or a pneumatic lifting tube. "

Reliable

ZE' Lift ELS™ is the most accurate system on the market. Its " robotic " accuracy provides great delicacy in the movement of the product, without shakes or vibrations.

This accuracy is also valid when the product is stopped. The progressive deceleration up to the virtual stop guarantees a perfect and precise stop of the movement.

- ▶ Result, the risk of damaging the load or the environment through uncontrolled shutdown is minimized.

health •••••

safety •••

profitability •••••

Fully secure power !

Accessories

Fixation

In the case of under rail installation, ZE' Lift ELS™ requires a set of fixation. The patented SAPELEM kit of fixation is preset in the plant.

- ▶ Result, the system is perfectly balanced, which prevents unintended vibrations and increases the life of facilities, equipment and protects the product being handled.

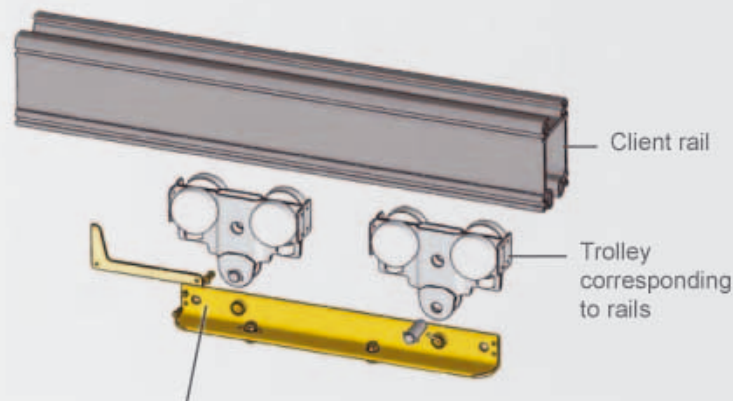

Fixation kit includes 1 setting up bracket and location specifically designed for trolleys matching rails + 1 festoon conductor

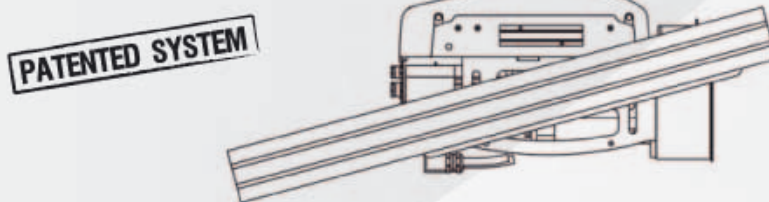

SAPELEM offers accessories such as matching trolleys with the rails your use.

- ▶ Result, your system, ZE' Lift ELS™ is ready to be installed directly beneath your track at delivery, without wasting time and with guaranteed results.

Offered standard : Demag* (Aluline 120 et 180, KBK1, KBK2), Ingersoll* (ZRA1, ZRA2), Tollo* (BGV100, 300) ...

➔ For any other rail, please contact us.

*All mentioned brands and names are registered trademarks by their respective owners.

health

safety

....

profitability

....



www.ze-solution.com

Electronic Lifting System

ZE' Lift ELS™

Other accessories

Variable frequency power supply

Standard : electric power supply 230V.A.C. +10% -15% single-phase 50 to 60 Hz.

Also available : 400 to 480 V.A.C. +10% -15% three-phase, neutral state TN or TT 50 to 60 Hz
230 V.A.C. +10% -15% three-phase 50 to 60 Hz
240 V.D.C. +/- 10%

Electric protection and pre-wiring

The supply of ZE' Lift ELS™ requires a switch box and an electric protection (10A). The box proposed by SAPELEM has been approved by our technical services.

▶ **Result, reliability assured.**

We also propose pre-wiring with our certified cables at the length of your choice.

▶ **Result, saving integration time, assurance and reliability success.**



see diagram
page 19

health

safety

profitability

Pneumatic filter regulator

In the case of a pneumatic power supply, it is mandatory to have between the network and ZE' Lift ELS™ a regulator and valve.

The filter regulator proposed by SAPELEM has been approved by our technical services.

▶ **Result, reliability assured.**



see diagram
page 19

➔ For certified electric cables, pipes specifically for vacuum, spiral pneumatic hose, stainless steel lift cables, please contact us.

Specifications

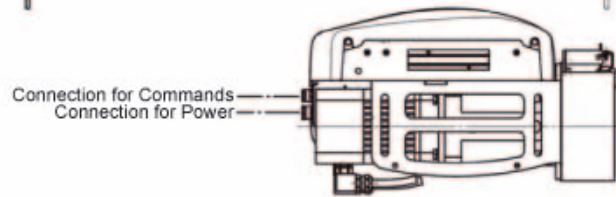
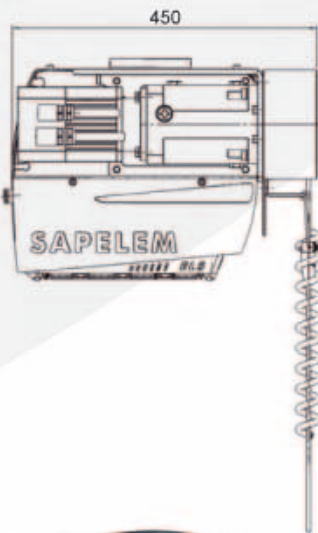
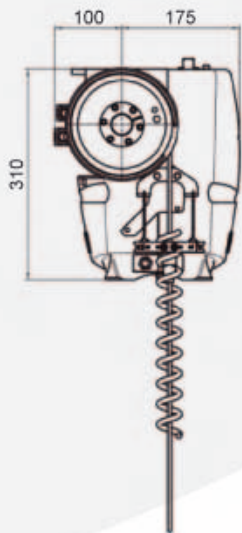
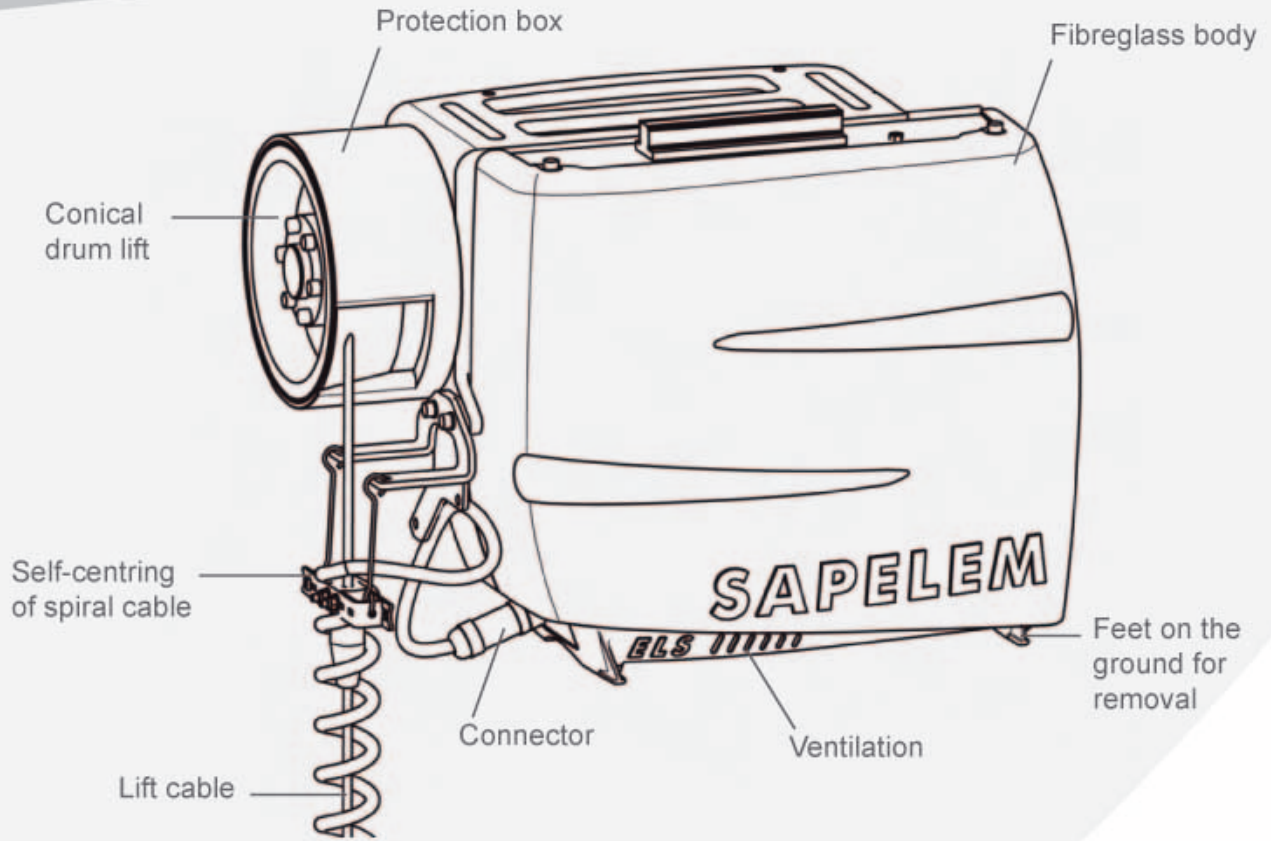

Flammability Rating
Body in self-extinguishing plastic classified UL 94-V0

Protection rating against solid and liquid objects
Engine and gearbox tested IP 65 according to EN 60 529 standard.
Mechanical brake tested IP 65 according to EN 60 529 standard.

Electric power supply 1.5 kw

Lifting cable

Steel Cable, safety factor 5 according to EN 14 238 standard.



Multi-articulated aluminium arm

ZE' Arm R2a™

Rotative Aluminium Arm

Versatile

Electric and pneumatic power, vacuum
Accessory fastening slots
Variety of actuators

Fluid

Set in motion less than 50 grams
Lightweight : aluminium
Rolling bearings

Secure

Positive connections
Protected
Anti-drift

Configurable

Satellite rotation : simple, double
Main rotation : 360°

Multipurpose

On the floor, ceiling, under rail or wall
Protection stops

Competent

Capacity : up to 300 Kg
Range : up to 4.7 m

Accurate and reliable, ZE' Arm R2a™ increases productivity while maintaining a high safety level for the operator and the environment. Adaptable to all situations, R2a is essential for those requiring real ergonomics.

The slight frames that beat all the heavyweights !



Competent

The ergonomic arms often have very small reach, forcing the user to have a bad location or to use the rails or lifting stems whose lateral effort exerted by the operator is much more important.

SAPELEM used **resistant materials** and appeals to **robust installation processes**.

▶ Result, ZE' Arm R2a™ covers a large area for operations.

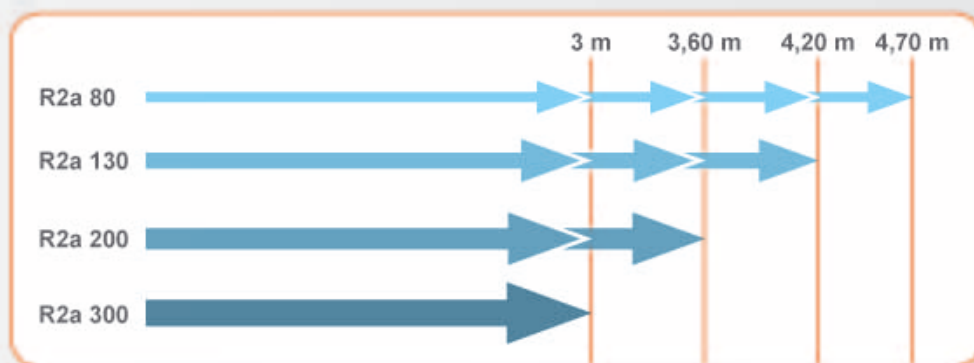

⚠ For the range without intermediate arms (single linkage), the maximum range is reduced by 24 cm.

health

safety •

profitability ...

Fluid

In ergonomics, the first quality of a load-bearing structure is to make it unfelt. That is why it is important to take into account the effort to move this structure. SAPELEM uses aluminium for the arm and connecting parts. Rotations are all on bearings. The actuator ELS is integrated behind the arm, in a neutral zone.

▶ Result, with less than 50 grams to start, to begin operation, the operator exerts less of side efforts. Cycle times decreases significantly for smaller loads.

health

safety •

profitability



OPINION OF EXPERT : Mr. BLOUIN, ergonomic adviser

" When it comes to ergonomics, everyone focuses on lifting. But we must remember that the operator also has to handle the load at a horizontal level. And if the system cannot do anything to lighten the load, the biggest attention must be paid to the weight of the structure and friction. Otherwise, what we gain vertically, we will lose horizontally.

ZE' Arm R2a™ is really the best solution. "



Multi-articulated aluminium arm

ZE' Arm R2a™

Rotative Aluminium Arm

Configurable

The installation of a lifting structure or an arm is a key point in ergonomics.

Traditional galleys intended for lifting have one turnover and are cumbersome to handle, especially when the operator is close to the barrel. Their location offers no alternative.

ZE' Arm R2a™, like the human arm, has two rotations, shoulder and elbow. An additional rotation (intermediate arm) can be added to face all situations of movement, right or left.

- ▶ Result, implementation is done without constraints and the operator exerts as little side efforts as possible. Cycle times become reduced.

health ●●●●●

safety ●

profitability ●●●

Rotation of the main arm

The 360° rotation allows for full coverage, on pillar as on ceiling.

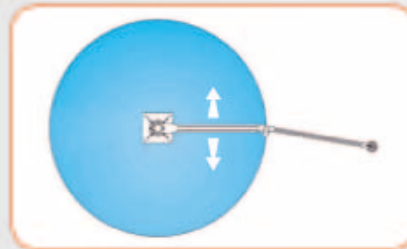

Satellite rotation arm

The satellite arm is connected to the main arm with two possibilities : simple or double articulation.

Double articulation

The double articulation makes it possible to have no limitation of movement. It is suitable for all situations. It withstands changes in the environment: The covered zone allows the operator to maintain excellent ergonomics. It is the best ergonomic configuration.

Simple articulation

The simple articulation meets economic expectations. It is suitable for areas of reduced work and stable with time.

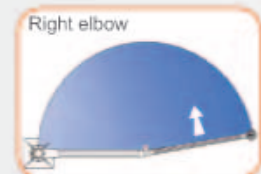
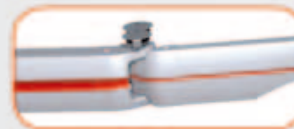
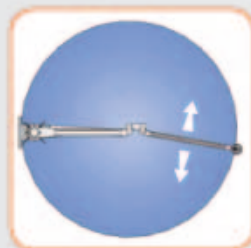

- ➔ Upgrade : double articulation can be established on ZE' Arm R2a™ simple articulation later, if necessary. (Changing environmental constraints, flows, or moving for example).

Examples of implementation

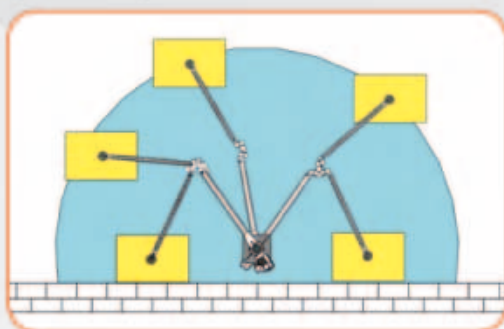

Maximum configuration, double articulation necessary

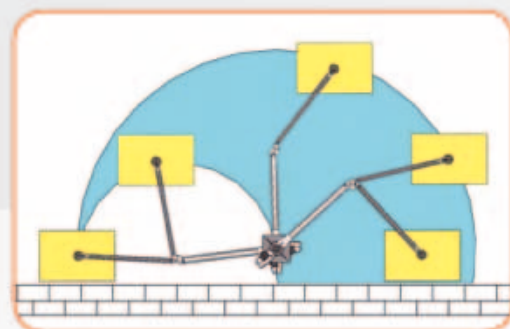

Reduced configuration, simple articulation sufficient

Move effortlessly !

It adapts to your environment

ZE' Arm R2a™ accommodates your constraints

ZE' Arm R2a™ was originally designed to cope with all the situations: On the ground, under ceiling, on rails, wall-mounted*.

▶ Result, the arm adapts to your environment and its constraints, and not the opposite.

* It is the responsibility of the owner of the structures to ensure they have the necessary strengths.

The most standard installation



Installation on the ground

cost ++

Need place on the ground ?



Installation to the ceiling

cost +

Need to cover a large surface area ?



Installation on rails

cost + + + + +

Secure

To obtain its CE Certification, ZE' Arm R2a™, has undergone millions of cycles. They have helped to validate the CAO calculations.

The connections between the sections and connection parts are positive.

The end of the arm, the most exposed to shocks, is protected by a rubber shock profile.



To protect the operator of unanticipated movements, all rotations are fitted with active anti-drift. At rest ZE' Arm R2a™ is stable in all positions.

health ..

safety

profitability ...

Versatile

ZE' Arm R2a™ integrates naturally into the ELS lifting system. Some users, however, prefer to conserve energy and use a pneumatic balancer. In that case, R2a has a universal fixing plate to the rear which allows the choices. Therefore, R2a also adapts to old technologies.



health .

safety .

profitability ...



Multi-articulated aluminium arm

ZE' Arm R2a™

Rotative Aluminium Arm

Options

Installation to ceiling

The specific focus (main arm rotation) is available upon request.

⚠ This option must be declared when placing order.

Accessories

Attachments

Pillar to affix to ground.
Please consult us.

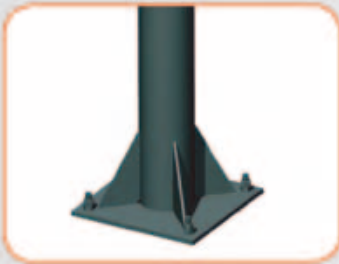

Moving base with screws to adjust level.
Please consult us.

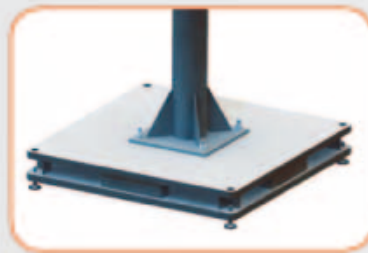

Trolley on rails. Please consult us

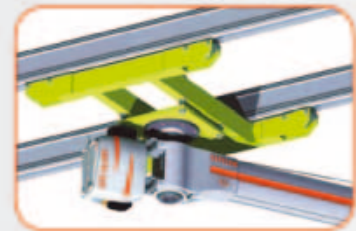

Rotating joint

This option allows for rotation of more than one turn with the main arm.

End stops

Because your environment is full of equipments which must be handled with care and the operator must remain focused on the task, the amplitudes of the arm movements can be limited. As such, you have the possibility to request adjustable end stops that will affect each rotation.

Attachment of accessories

ZE' Arm R2a™ has T-shaped attachment grooves which allow securing many accessories in complete safety and simplicity. As such, you can integrate vacuum tubes or compressed air in case of pneumatic actuators, lighting, boxes ...

➔ Consult us for tools you required (T-bolts, ...).

Under arm secured lighting



Specifications

Double articulation

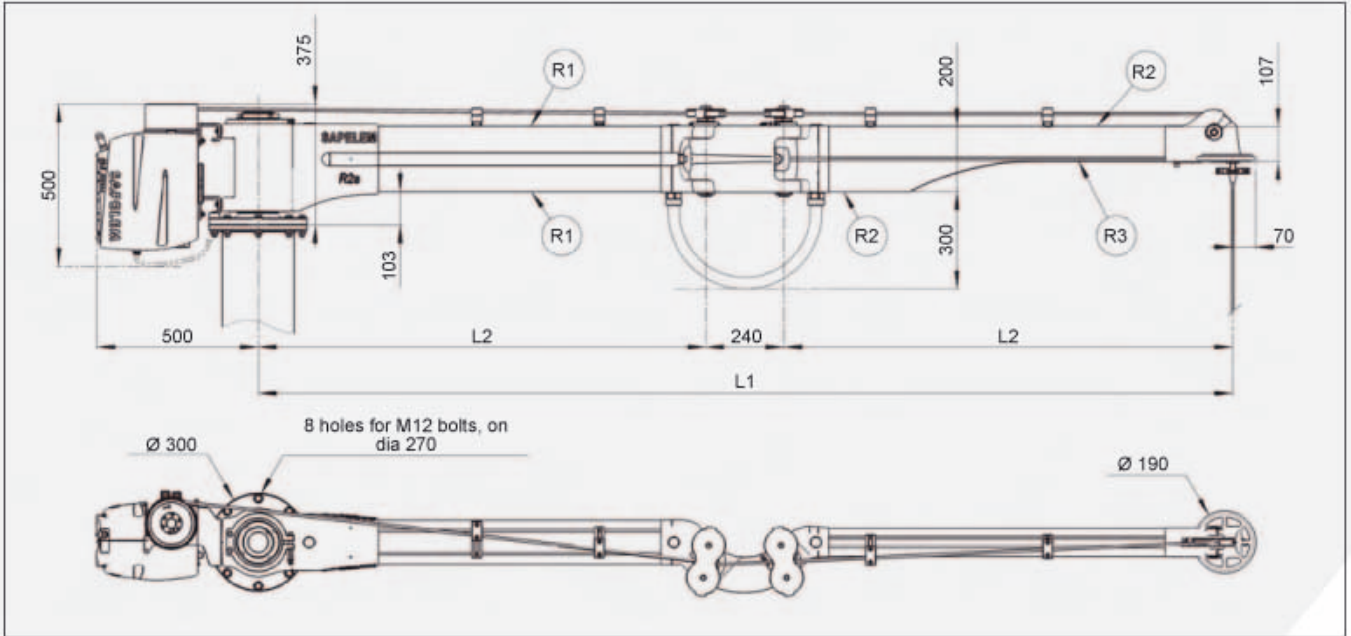

Simple articulation

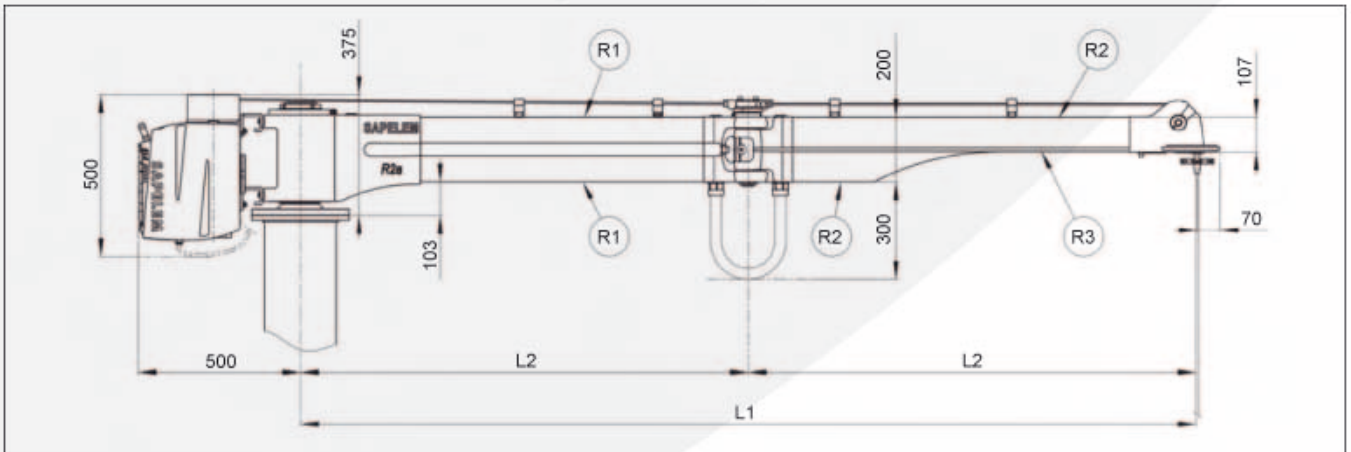

Double articulation	L1 = 3000	L1 = 3600	L1 = 4200	L1 = 4700
Simple articulation	L1 = 2760	L1 = 3360	L1 = 3960	L1 = 4460
R2a 80	L2 = 1380	L2 = 1680	L2 = 1980	L2 = 2230
R2a 130	L2 = 1380	L2 = 1680	L2 = 1980	
R2a 200	L2 = 1380	L2 = 1680		
R2a 300	L2 = 1380			

T-grooves	Δ
R1	71
R2	28,5
R3	53,5

Installation under ceiling

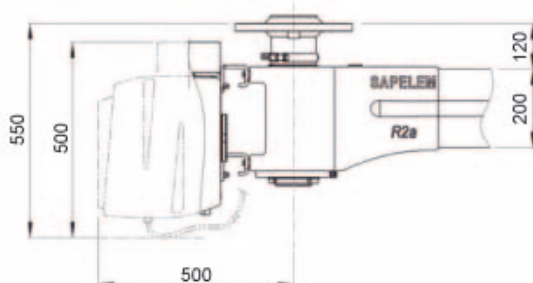

T-grooves

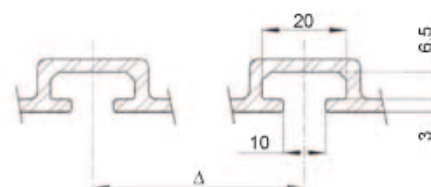

Your Orchestra Conductor

ZE' Soft™

Built-on software

ZE' Soft™ is your orchestra conductor : it controls your settings, works on the actuators, constantly scrutinizes your sensors, and controls the unanticipated unknowns.

Result, you play the music in complete safety.

Ergonomic and simple

- Parameter by intuitive dropdown menus
- Memorizes each user's parameters
- Sensitivity adjustable and variable
- Controls loads and its variances
- Automatic start-up

Active security

- Applies conditions to actions at risk
- Passwords and associated rights
- DSC, Dynamic Stability Control
- Compensates for power failure
- ACS, Anti Shock System

Reactive and Reliable

- Preserves operator's touch
- Reacts without delay
- HDY, High Dynamic
- Intuitively driven

Assists operator

- Provides value-added information
- Virtual reality / hyper ergonomic
- Assistance for X / Y movements
- Increased reality

Extended functions

- Adjustable settings, it adapts to all situations
- Integrated programmable automaton
- Vacuum handling special modulus
- Helps emptying and refilling
- Maintenance tools
- Communicative

Personalisation

ZE' Soft™ facilitates all !

Reactive and reliable



Reactivity and reliability are essential for the user to accept a device. ZE' Soft™ has been the subject of many studies before arriving at its current form : the load instantly follows the operator's hand movements. You play intuitively, and your movements are interpreted with great accuracy.

Controls movements

ZE' Soft™ constantly checks the sensors of ZE' Joystick Zii™ and deduces the desired movements of the operator. ZE' Soft™ reacts in real time to the settings of ZE' Lift ELS™.

- ▶ Result, the load reliably follows the operator's hand movements without undue effort or specific intentions.

health

••••

safety

••

profitability

•••••

ZE' Soft™ - HDY (High Dynamic : speed and acceleration)

ZE' Soft™ with its HDY modulus, High Dynamic, closely imitates natural movements of the operator's hand. To achieve this, it controls in real-time the system with an acceleration of up to **1g** and a speed up to **2 m/s**.

The high performance combination of these two settings is the only possible way to achieve maximum speeds in short amplitude.

- ▶ Result, reduction of cycle time, on short or long runs, transparent material for the user, elimination of Musculoskeletal Disorders of the arm and shoulder.

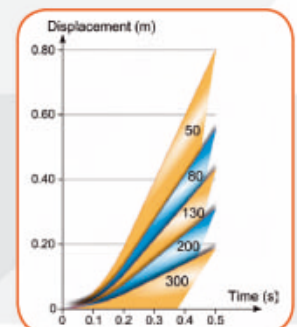

health

••••

safety

•

profitability

•••••

Reacts without delay

Reactive : the calculation speed of ZE' Soft™ is instantaneous on a human level.

Force feedback : ZE' Soft™ associated to ZE' Joystick Zii™ organizes a force feedback perceptible by the operator.

- ▶ Result, the operator feels the reactivity of the device and preserves the touch. It is more accurate and reliable. The machine becomes an ally to the operator.

health

•••••

safety

•

profitability

•••••



OPINION OF EXPERT : Mrs JOLIVET, business ergonomic specialist

" The weakness of the accelerations of traditional systems brings the operators to use more force than necessary on the handle. This attitude is a human reaction: when a system is either not working or malfunctioning, the operator tends to compensate. This causes tendonitis and frustrations to the operator. One of the most reported consequences is absenteeism or refusal to act as an operator at the temptation to continue manually. "



Your Orchestra Conductor

ZE' Soft™

Built-on software

Active security : Ensuring and preventing

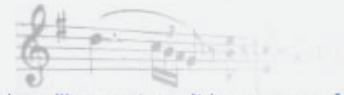

ZE' Soft™ has been the subject of important studies to ensure the security of your handling system. It is a group of programs that work intelligently in collaboration with the various integrated electronic systems of ZE' SOLUTION™ to ensure an **active security**.

ZE' Soft™ is the orchestra conductor that ensures that your musicians play their musical scores without any wrong notes.

ZE' Soft™ - DSC (Dynamic Stability Control)

PATENTED SYSTEM

DSC is an active security system of type ESP (Electronic Stability Control) that can be found in upscale cars. It allows the prevention of incidents due to uncontrolled behaviours. It maintains the system stable by acting on ZE' Lift ELS™ (speed, acceleration) and on ZE' Joystick Zii™ (sensitivity).

- ▶ Result, ZE' Soft™- DSC keeps the handling system secure, avoiding dynamic excess, improving the device's ergonomics, making it easier and more reactive.

ZE' Soft™ - DSC is an essential complement to high dynamics driven by ZE' Soft™ - HDY.

Main functions :

- Active absorption of the vibratory effects on weight-bearing structures.
 - No more joystick pumping effects .
 - No more chaotic amplifications.
 - Control of the operators' speed excess.
 - Automatic stability of the handling system in case of any sudden drop of load or sudden weight increase.
 - Variable sensitivity according to speed: the operator can control the system better when reaching high speed.
- In addition to receiving great reactivity at start up.

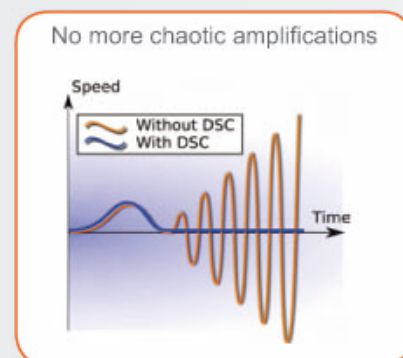
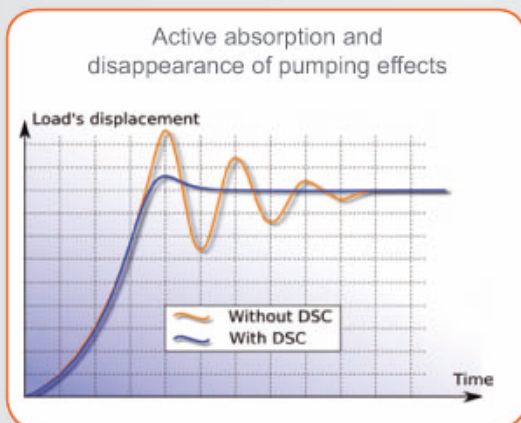

Applies conditions to actions at risk

Grip : Lifting the load can be done only when the grip is confirmed the by the detectors.

Release : The load releasing can be done only when it has been layed down on a stable area.

Hand presence : The movements are conditioned by the detection of the hand (see ZE' Joystick Zii™ page 10).

Load weight : The handling system can't work if the load is more than the rated capacity of the manipulator or of the gripper. Because of automatic safety, the operator doesn't waste time.

health ...

safety

profitability ..

ZE' Soft™ protects all !

ZE' Soft™ - ASS (Anti Shock System)

PATENTED SYSTEM

ASS is an active security program like ABS (Antiblockiersystem) that assists the braking in cars. It enables the prevention of incidents related to abrupt movements of the system, whether voluntary or intended. It optimizes stopping movements and oversees the slowdown of the device by acting on ZE' Lift ELS™ (speed, acceleration) while preserving the accuracy and intent of the operator.

- ▶ Result, ZE' Soft™- ASS while avoiding dynamic overloads associated with sudden slowdowns or stops, it removes the risk of dropping the load. It protects the operator, the premises, and the environment.

ZE' Soft™ - ASS is an indispensable complement to the high dynamics controlled by the modulus ZE' Soft™ - HDY.

Main functions :

- Stop damping in the case of hazards : emergency stops generated by the DSC (abrupt fall of load ...) power failure.
- Control of deceleration during inversion of movement.
- Securing the breakdown of the control handle ZE' Joystick Zii™ during movement.
- Deceleration settings during stops and at virtual end stops.
- Shock management : alarm triggering, slowing down or stopping of movement, handle lock-in according to settings.

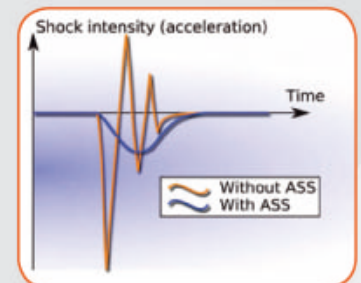

health ...

safety

profitability ..

Passwords and rights

PATENTED SYSTEM

Using ZE' SOLUTION™ is password-protected. Each user has controlled access, granting rights related to the movement of the machine on consultation of information and settings.

With the modulus ZE' Soft™ - MULTI, several profiles are available : Operators 1 to n, production, methods, maintenance, integration, administrator ...

- ▶ Result, your handling system cannot be used without authorization : as such, risk of accidents is reduced. Changes of settings are impossible to those who do not have access rights.



health ...

safety

profitability



OPINION OF EXPERT : Mr LORIENT, psychologist

" The operator's stress is mechanical (MSD), but is also psychological. The higher the work pace, the more fragile the products or the environment, the more increased is the operator's [mental] stress. This stress increases absenteeism, reduces productivity and is detrimental to the health of the operator. This may cause errors leading up to accident, or absenteeism. We found that ZE' Soft™ system relieves mental stress of the operator carrying out the task because of the equipment's ensured safety. "



Your Orchestra Conductor

ZE' Soft™

Built-on software

Simple and ergonomic

ZE' Soft™ is the result of important research study so that ZE' SOLUTION™ adapts automatically to situations. It helps you write your scores with ease.



ZE' Soft™ - MULTI

ZE' Soft™ with its multi modulus optimizes the settings for each operator and for each of the handling processes. It stores per user: Access rights, sensitivity, maximum speed, maximum acceleration, displays, selected languages ...

- ▶ Result, the machine adapts to the operator and not vice versa. No time wasted on parameter settings for every use, and no obligation to use a machine set for a less productive operator.

health

safety

profitability

Human Interface / Simple Machine

Dropdown menu : ZE' Soft™ settings are done through dropdown menus. It is therefore intuitive and does not require heavy documentation nor specific training.

Embedded software : ZE' Soft™ is fully embedded in the control handle. No computer is necessary to make changes to settings or perform diagnostics.



health ..

safety ..

profitability

Controls load and its variations

ZE' Soft™ adapts automatically and at any time to all parameters of the system related to the weight of the load. And regardless to the load, the system maintains the same behaviour in sensitivity, speed, and acceleration.

ZE' SOLUTION™ is perfectly suited for filling or emptying of contains.

- ▶ Result, the operator can handle the weight-varying load without prior adjustment or loss of sensitivity of the load.

health

safety ..

profitability

Additional functions :

- Differential sensitivity upwards and downwards: reduces the weight of the arm of the operator.
- Getting started automatically at power on.
- Automatic modulus settings at installation.
- Function controlling the change of ZE' Lift ELS™ cable.

ZE' Soft™ helps you with all !

Assists the operator

To help the operator in achieving the desired task, ZE' Soft™ provides value-added information allowing the operator to save time, while staying reliable. It helps you play the most difficult melodies while maintaining harmony.

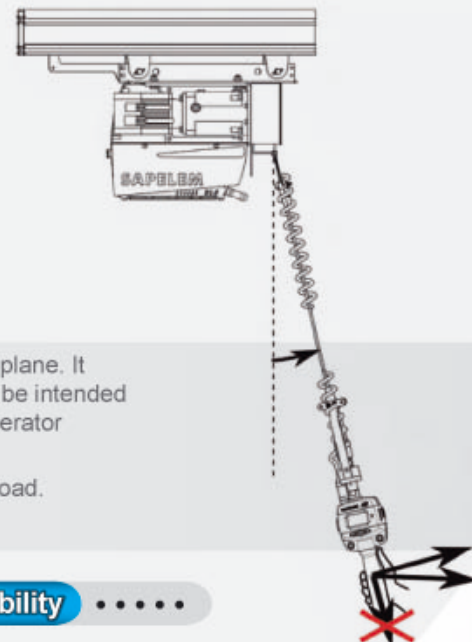

Assistance to horizontal movements

PATENTED SYSTEM

Assistance to travel horizontally as the operator moves the load on a horizontal plane. It naturally exerts instructions of descent on the command handle, which may not be intended by the operator. This well-known phenomenon is amplified in track X, Y. The operator compensates making significantly unnecessary efforts.

ZE' Soft™ automatically detects this phenomenon and stops the descent of the load.

▶ Result, the operator is faster and makes less effort.

health

.....

safety

...

profitability

.....

Asserted reality / Hyper ergonomics

ZE' Soft™ provides real-time contextual information from the ongoing scanning sensors of the gripper or the environment. It transmits the instructions provided by the network of the factory by enriching them. This information is sound and visual.

▶ Result, ZE' Soft™ increases the reality perceived by the operator and provides for clearer actions and quicker decisions, allowing the operator to become faster.

Examples of assistance :

- Next task to be performed
- Displays position of load (significantly useful during assembling operations)
- Displays messages in case of malfunction
- Displays information from sensors. Example: distance, weight ...

health

.....

safety

..

profitability

.....

Virtual reality

ZE' Soft™ integrates the technology of virtual reality used particularly in high-risk facilities such as nuclear. ZE' Soft™ makes it possible to identify positions where the movements must be reduced, zones where movements of rise / fall are forbidden in order to improve safety.

Virtual stops

ZE' Soft™ allows storing high and low virtual stops and ranges of deceleration to arrive at reduced speed. The operator can use a higher speed far from the zone of gripping area while guaranteeing a slow approach that protects the product.

▶ Result, the operator saves time and has less negative stress, and your products are protected from shock.

Virtual meeting points

ZE' Soft™ also allows storing a virtual meeting point. It allows the gripper to stop at a given position without losing time on iterative adjustments.

▶ Result, the operator gains a lot of time to go to the target point.



To set virtual places, only use keyboard and dropdown list

health

.....

safety

.....

profitability

.....



Your Orchestra Conductor

ZE' Soft™

Built-on software

Extended functions



ZE' Soft™ has numerous features that are the result of the consultations of professional ergonomists, doctors and frequent users. ZE' Soft™ plays all scores.

Display

Displays in the language of your choice* among the value-added information: speed, total number of cycles, average duration of a cycle, maximum load ...

*The available languages are in English, French, Spanish and German. For other languages, please consult us.

health

...

safety

.

profitability

...

Easily installable

It allows ZE' SOLUTION™ to adapt to all situations. Configuration is quick and easy, requiring no training.

Settings are automatically saved and appear the same after a power cut. There is no need to explicitly trigger the backup after a setting. It is not necessary to activate explicitly the backup copy.

▶ Result, saving time and increasing reliability.

health

.....

safety

..

profitability

.....

Daily report

It records all events in a journal available on ZE' Joystick Zii™ or on a management PC.

This can easily analyze the task or carry out diagnoses.

ZE' Soft™ - LOAD (Aid at emptying/filling)

PATENTED SYSTEM

Associated with a load cell (see ZE' Joystick Zii™ page 13), ZE' Soft™ - LOAD module makes known the exact weight of the load. ZE' Soft™ - LOAD assists the operator in proportioning operation : it displays weight, generates an alarm when the change in weight is consistent with the desired objective, and graphically displays the situation in relations to the objective. The parameter setting of the displays and objectives are very simple.

health

.....

safety

.....

profitability

.....

ZE' Soft™ - VAC

PATENTED SYSTEM

Combined with a vacuum generator (see packs ZE' SOLUTION™ on page 39), ZE' Soft™ - VAC is a module that manages gripping by vacuum : it displays on ZE' Joystick Zii™ screen the level of vacuum, activates an alarm when the vacuum level is under the security limit or in case of power cut. It authorizes lifting when the product grip is confirmed, and allows removal of the load once it is certain that the load is put down on a support. This module saves energy, and helps to ensure compliance with standard EN 14238, " safety of manually controlled load handling devices " .

health

.....

safety

.....

profitability

.....

ZE' Soft™ takes care of all !

ZE' Soft™ - GRIP

Combined with a push-out collect chuck by a pneumatic cylinder, ZE' Soft™ - GRIP is a module that manages the grip by clamping. It conditions the authorization of lifting to a confirmed grip. It conditions the removal of the load in the assurance that it is put on a support. It generates an alarm when pressure is below safety limit or in case of power failure. This module ensures the compliance of the gripper with EN 14238, " safety of manually controlled load handling devices " .

health

safety

profitability

ZE' Soft™ - MAI

PATENTED SYSTEM

Contains a set of tools for preventive and curative maintenance.

Preventive : It displays messages of intervention after a period or a configurable number of cycles. It can also block the use of ZE' SOLUTION™ if certain defined thresholds are reached.

Curative : Displays messages of diagnosis help in case of failure (overload, over-current ...).

health .

safety

profitability

Personalization

ZE' Soft™ has been designed in an entirely modular and open way so as to adapt to particular commands. As such, ZE' Soft™ is an evolving platform that allows to take into account your specific needs. Language, display, new settings, new features ...

➔ Please contact us for a customization of the displays, conditioned actions, formats of data exchanged with the factory network, the incorporation of GRAFCET to operate as active grippers

▶ Result, ZE' Soft™ allows to have a solution that sticks to your needs. ZE' SOLUTION™ adapts itself to you, and not vice versa.

health

safety .

profitability

Configuration



High Dynamics ZE' Soft™ Pack : ZE' Soft™ Basic + all " Dynamics " Modules

ZE' Soft™ Full Pack : ZE' Soft™ Basic + all " Dynamics " Modules + all " Functions " Modules



ZE' SOLUTION™ SAPELEM PACKS

Different configurations

Because certain required ZE' SOLUTION™ configurations are regularly found, SAPELEM handling and process offers 4 turnkey products.

ZE' SOLUTION ARM Pack

This package provides the most ergonomic solution to the applications pick / release in a work zone defined by the arm reach.



Found in this package are

- ZE' Joystick Zii™
- ZE' Lift ELS™ fitted to ZE' Arm R2a™
- ZE' Arm R2a™
- Pack ZE' Soft™

Elements specific to each application are of course also available :

- Fastener Interface (pole with ground-fixing plate, wall-fixing stage, pole with fixed connector base ...)
- Special gripper tool
- Various options presented in descriptions of each component

ZE' SOLUTION RAILS Pack

This package offers a solution to the applications pick / release in a large work zone.



Found in this package are

- ZE' Joystick Zii™
- ZE' Lift ELS™ with trolleys for the rails (on demand)
- Pack ZE' Soft™

In case of need for a turnkey ready workstation, SAPELEM handling and process, or its integrator is able to offer you complete equipment with rails and supports.

➔ This package can also be integrated under standard jib cranes. (This is a non-ergonomic solution, alternative to ZE' Arm R2a™ - see page 19, ZE' Lift ELS™ installation configurations).

ZE' SOLUTION Pneumatic and Vacuum Pack

These packs are pre-configured for current applications requiring flow (compressed air or vacuum). They are available both with ZE' SOLUTION ARM and ZE' SOLUTION RAIL.

Compressed Air Pack

This pack includes

- A compressed air supply line between the control handle ZE' Joystick Zii™ and the pneumatic connecting point.

This point is grouped with ZE' Lift ELS™ electric connecting point (valid in both configurations : ZE' Lift ELS™ and ZE' Arm R2a™). So you have one single place to bring the electric and pneumatic energies.

- ZE' Soft™ - GRIP (see page 37)

This pack allows supplying and controlling the actuators present on the gripper.

 Plan for the necessary connections.



Vacuum Pack

This pack includes

- A compressed air supply line between the control handle ZE' Joystick Zii™ and the pneumatic connecting point.

This point is grouped with ZE' Lift ELS™ electric connecting point (valid in both configurations : ZE' Lift ELS™ and ZE' Arm R2a™). So you have one single place to bring the electric and pneumatic energies.

- SMX™, vacuum generator, a product developed by SAPELEM Robotics with its fixation and connection technology linking it to ZE' Joystick Zii™.
- ZE' Soft™ - VAC (see page 36)

This package allows for supply and control of a gripper with suction pads.

 Following the air-tightness of the suction pads and the handled product, it may be necessary to add a vacuum reserve (not included).



REFERENCES

ZE' SOLUTION™ SAPELEM

Choose the spiral electric cable and the lift cable according to your layout

1 - Determining length of spiral electric cable :

Type of spiral cable	2	3	4	5	6	7	8
D : length of spiral cable (adjacent turns) in mm	200	300	400	500	600	700	800
C : maximum authorized run per spiral cable in mm	600	900	1200	1500	1800	2100	2400

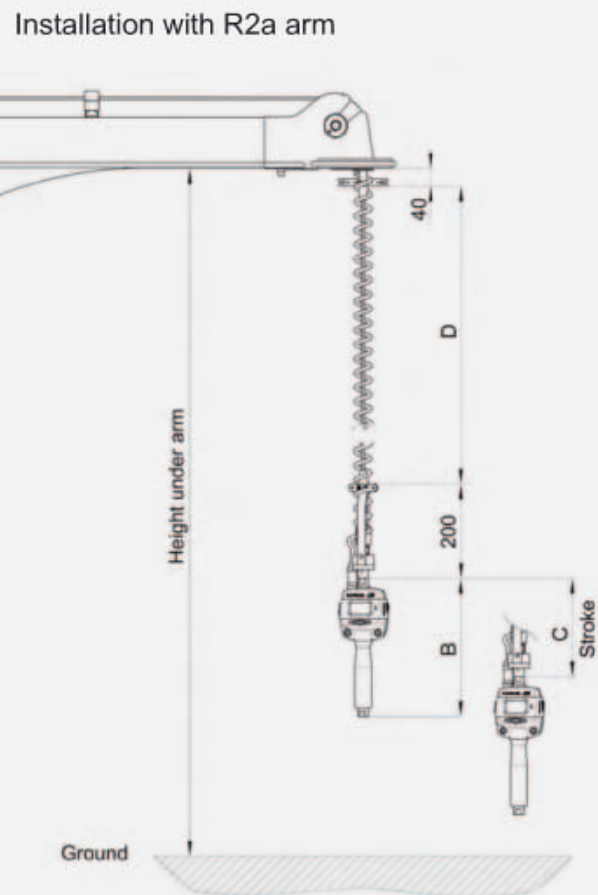
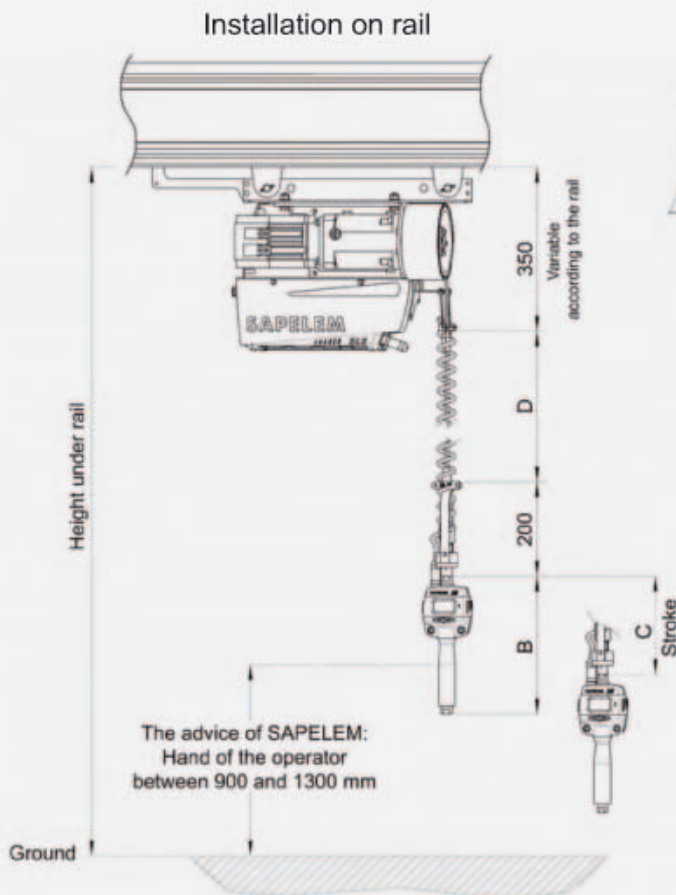

2 - Determining length of lift cable :

Installation on rail :

Maximum length of lifting cable = $4800 + D$

Minimum length = $1500 + D + C$

Installation with R2a arm :

Maximum length = $5000 + D + L1$

Minimum length = $2000 + D + C + L1$

(L1 = length of R2a arm, see page 29)

Choosing a lift cable compatible with calculated max and min lengths :

Type of lift cable	4	5	6	7	8	9	0
Length of lift cable in mm	4000	5000	6000	7000	8000	9000	10000

Find the right reference

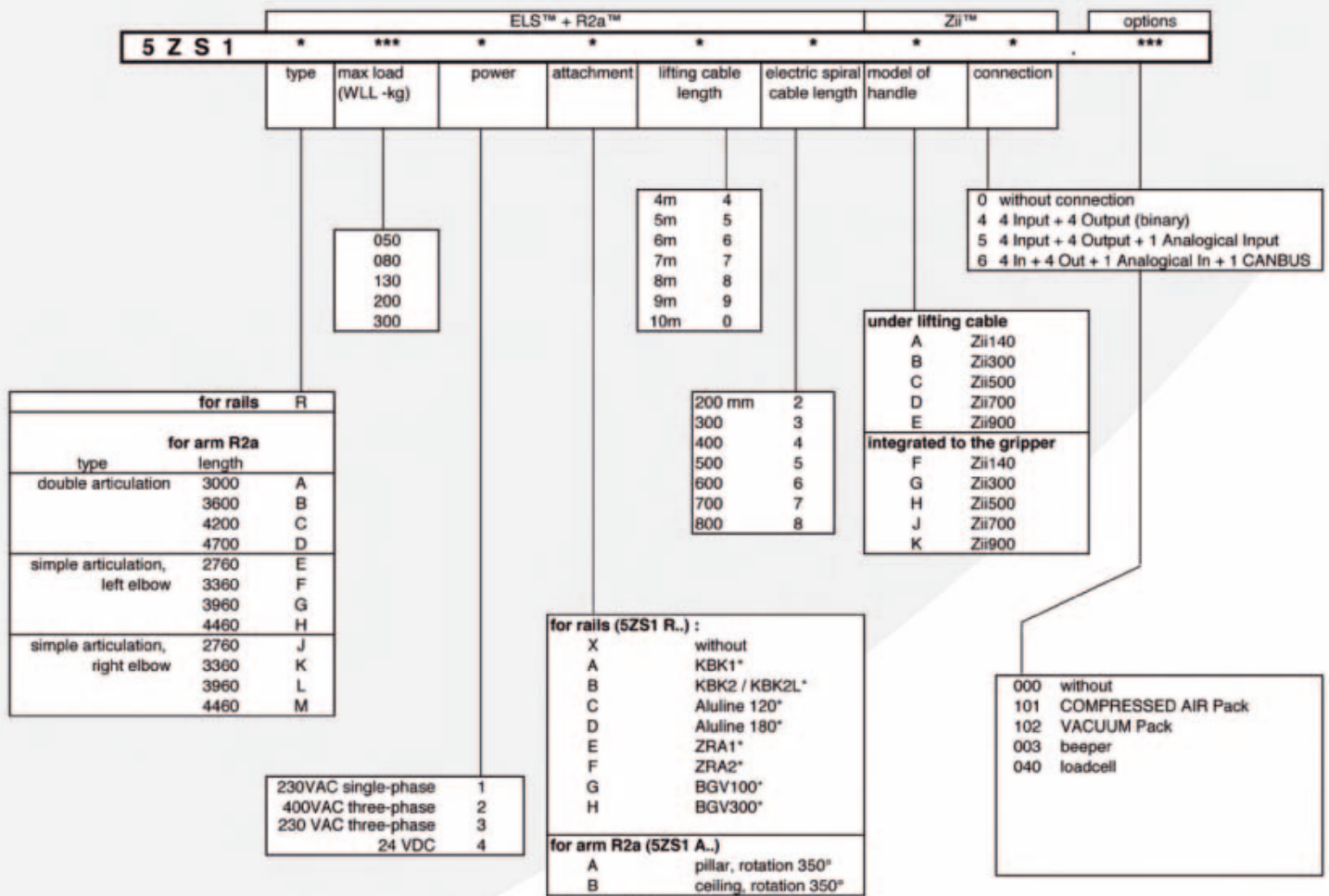

*All mentioned trademarks and trade names are registered trademarks by their respective owners. Trolleys are not supplied with attachment set

