

# PZN-plus

Pneumatic • 3-Finger Centric Gripper • Universal Gripper



**Sizes**  
40 ... 300



**Weight**  
0.13 kg ... 46 kg

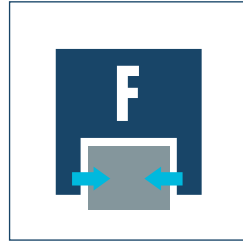

**Gripping force**  
255 N ... 35500 N



**Stroke per finger**  
2 mm ... 35 mm



**Workpiece weight**  
1.3 kg ... 127.5 kg

## Application example

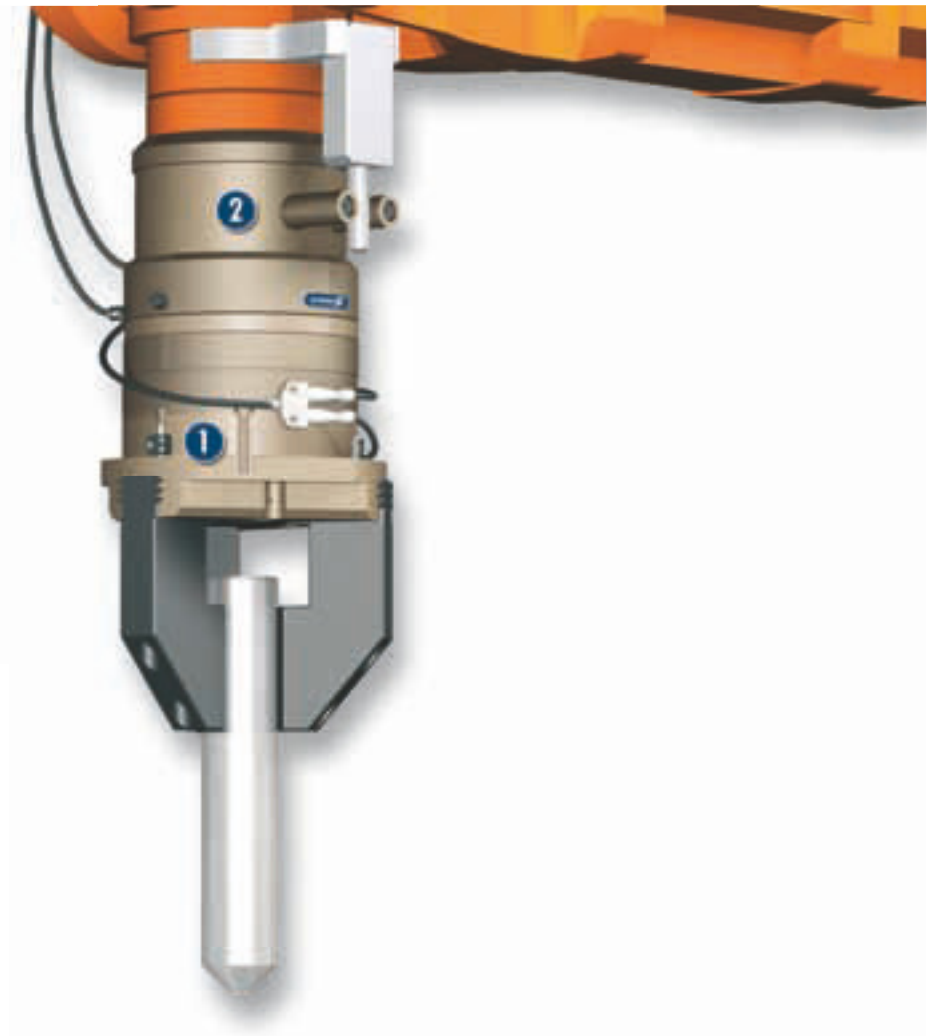

Insertion tool for assembling small to medium-sized axles. Thanks to the rotary feed-through, the axles can be turned several times to an unlimited extent ( $> 360^\circ$ ). Slip ring contacts integrated in the rotary feed-through reliably supply the gripper with power.

- 1 3-Finger Centric Gripper PZN-plus
- 2 Rotary feed-through DDF

### Universal Gripper

universal Concentric Gripper with high gripping force and maximum moments thanks to multi-tooth guidance

### Field of application

Multi-purpose thanks to the diverse range of accessories. Can also be used in fields of application with special requirements to the gripper (temperature, chemical resistance, dirt, and many more).

### Your advantages and benefits

#### Robust multi-tooth guidance

for precise handling

#### High maximum moments possible

suitable for using long gripper fingers

#### Wedge-hook design

for high power transmission and synchronized gripping

#### Air supply via hose-free direct connection or screw connections

for the flexible supply of compressed air in all automation systems

#### Comprehensive sensor accessory program

for versatile interrogation possibilities and control of stroke position

#### Manifold options

for perfect adaption to your case of application (dust protection, high temperature, anti-corrosion and many more)



### General note to the series

#### Principle of function

Wedge-hook kinematics

#### Housing material

Aluminum alloy, hard-anodized

#### Base jaw material

Steel

#### Actuation

pneumatic, with filtered compressed air (10 microns): dry, lubricated or non-lubricated

Pressure medium: Required quality class of compressed air according to

DIN ISO 8573-1: 6 4 4

#### Warranty

36 months (details, general terms and conditions and operation manuals can be downloaded under [www.schunk.com](http://www.schunk.com))

#### Scope of delivery

Brackets for proximity switches, centering sleeves, O-rings for direct connection, assembly and operating manual with manufacturer's declaration

## Sectional diagram

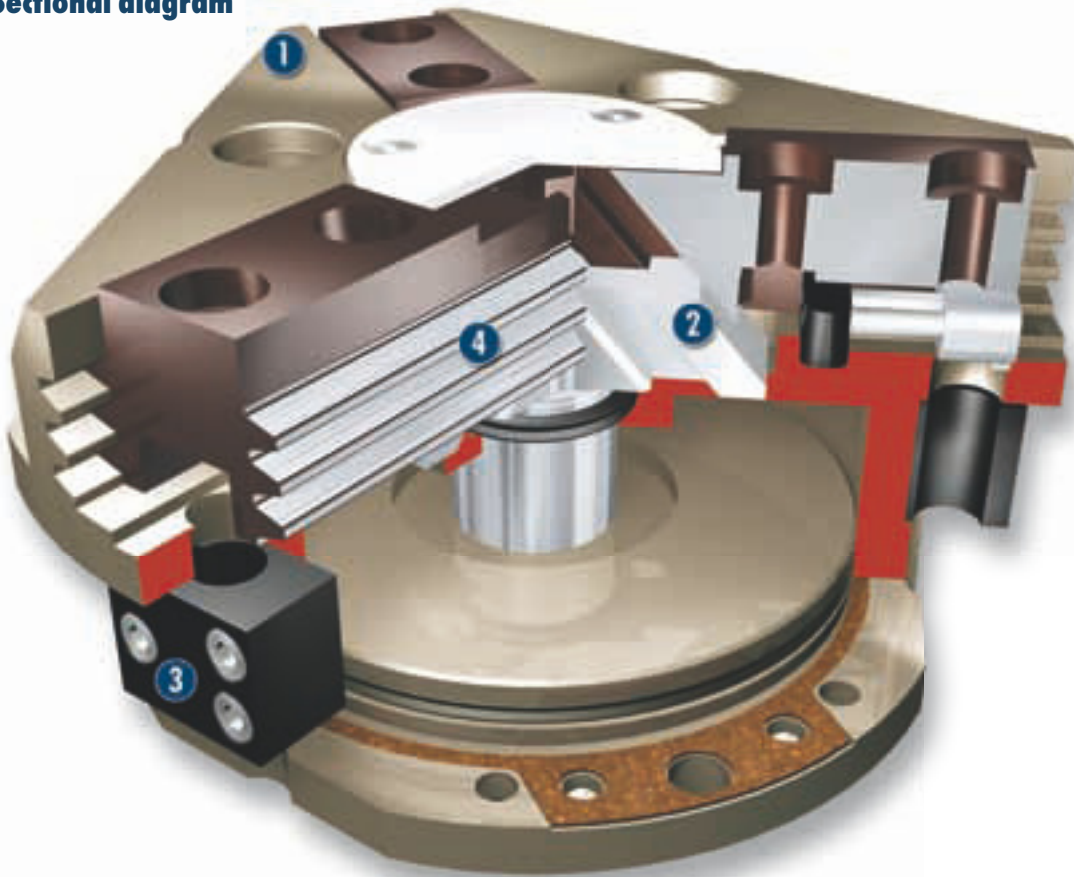

- 1 Housing**  
weight-optimized through application of hard-anodized, high-strength aluminum alloy
- 2 Wedge-hook design**  
for high power transmission and centric gripping

- 3 Sensor system**  
Brackets for proximity switches and adjustable control cams in the housing
- 4 Multiple-tooth guidance**  
precise gripping through base jaw guidance with a high load capacity and a minimum play

## Functional description

The piston is moved up and down by compressed air. Through its angled active surfaces, the wedge hook transforms this movement into the lateral, synchronous gripping movement of both base jaws.

## Options and special information

### Dust-protection version

Absolutely sealed, increased degree of protection against the ingress of materials, for use in dusty environments

### Anti-corrosion version

for use in corrosion-inducing atmospheres

### High-temperature version

for use in hot environments

### Force intensified version

if higher gripping forces are required

### Accessories

Accessories from SCHUNK – the suitable supplement for maximum functionality, reliability and performance of all automation modules.

Sensor system



Fittings



Universal intermediate jaw



Compensation unit



Protection cover



Sensor cables



Quick-change Jaw System



Sensor Distributor



Pressure maintenance valve



Finger blanks



Force measuring jaws



Analog position sensor



Flexible Position Sensor



① For the exact size of the required accessories, availability of this size and the designation and ID, please refer to the additional views at the end of the size in question. You will find more detailed information on our accessory range in the "Accessories" catalog section.

### General note to the series

#### Gripping force

is the arithmetic total of the gripping force applied to each finger at distance P (see illustration) measured from the upper edge of the gripper.

#### Finger length

The finger length is measured from the upper edge of the gripper housing in the direction of the main axis.

#### Repeat accuracy

is defined as the spread of the limit position after 100 consecutive strokes.

#### Workpiece weight

The recommended workpiece weight is calculated for a force-type connection with a coefficient of friction of 0.1 and a safety factor of 2 against slippage of the workpiece on acceleration due to gravity g. Considerably heavier workpiece weights are permitted with form-fit gripping.

#### Closing and opening times

Closing and opening times are purely the times that the base jaws or fingers are in motion. Valve switching times, hose filling times or PLC reaction times are not included in the above times and must be taken into consideration when determining cycle times.

# PZN-plus 40

Pneumatic • 3-Finger Centric Gripper • Universal Gripper



## Gripping force, I.D. gripping

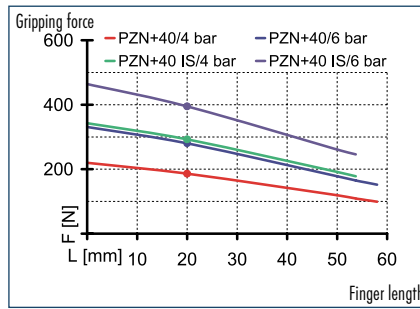

## Gripping force, O.D. gripping

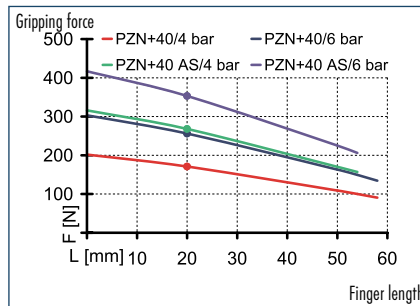

## Finger load

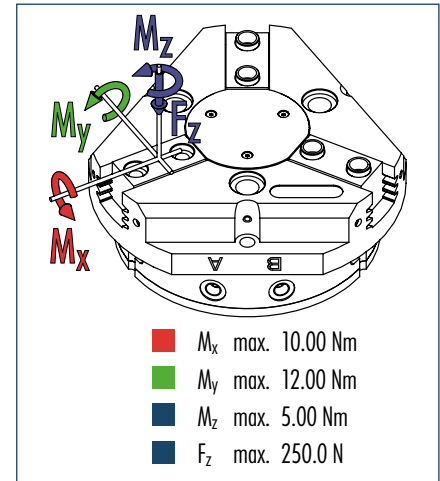

① The indicated moments and forces are static values, apply per base jaw and may occur simultaneously.  $M_y$  may arise in addition to the moment generated by the gripping force itself. If the max. permitted finger weight is exceeded, it is imperative to throttle the air pressure so that the jaw movement occurs without any hitting or bouncing. Service life may be reduced.

## Technical data

Description	PZN-plus 40	PZN-plus 40-AS	PZN-plus 40-IS
ID	0303308	0303508	0303538
Stroke per finger [mm]	2.5	2.5	2.5
Closing force [N]	255	355	
Opening force [N]	270		370
Min. spring force [N]		100	100
Weight [kg]	0.13	0.15	0.15
Recommended workpiece weight [kg]	1.3	1.3	1.3
Air consumption per double stroke [cm <sup>3</sup> ]	5	9	9
Min./max. operating pressure [bar]	2/8	4/6.5	4/6.5
Nominal operating pressure [bar]	6	6	6
Closing/opening time [s]	0.03/0.03	0.02/0.04	0.04/0.02
Max. permitted finger length [mm]	58	54	54
Max. permitted weight per finger [kg]	0.1	0.1	0.1
IP class	40	40	40
Min./max. ambient temperature [°C]	-10/90	-10/90	-10/90
Repeat accuracy [mm]	0.01	0.01	0.01
Cleanroom class			
ISO-classification 14644-1	5	5	5

## OPTIONS and their characteristics

Dust-protection version	37303308	37303508	37303538
IP class	64	64	64
Weight [kg]	0.16	0.18	0.18
Anti-corrosion version	38303308	38303508	38303538
High-temperature version	39303308	39303508	39303538
Min./max. ambient temperature [°C]	-10/130	-10/130	-10/130
Force intensified version	PZN-plus 40-KVZ	PZN-plus 40-AS-KVZ	PZN-plus 40-IS-KVZ
ID	0372199	0372219	0372239
Closing force [N]	410	510	
Opening force [N]	432		532
Weight [kg]	0.19	0.21	0.21
Maximum pressure [bar]	8	6	6
Max. permitted finger length [mm]	50	40	40
Precision version	0303338	0303488	

## Main view

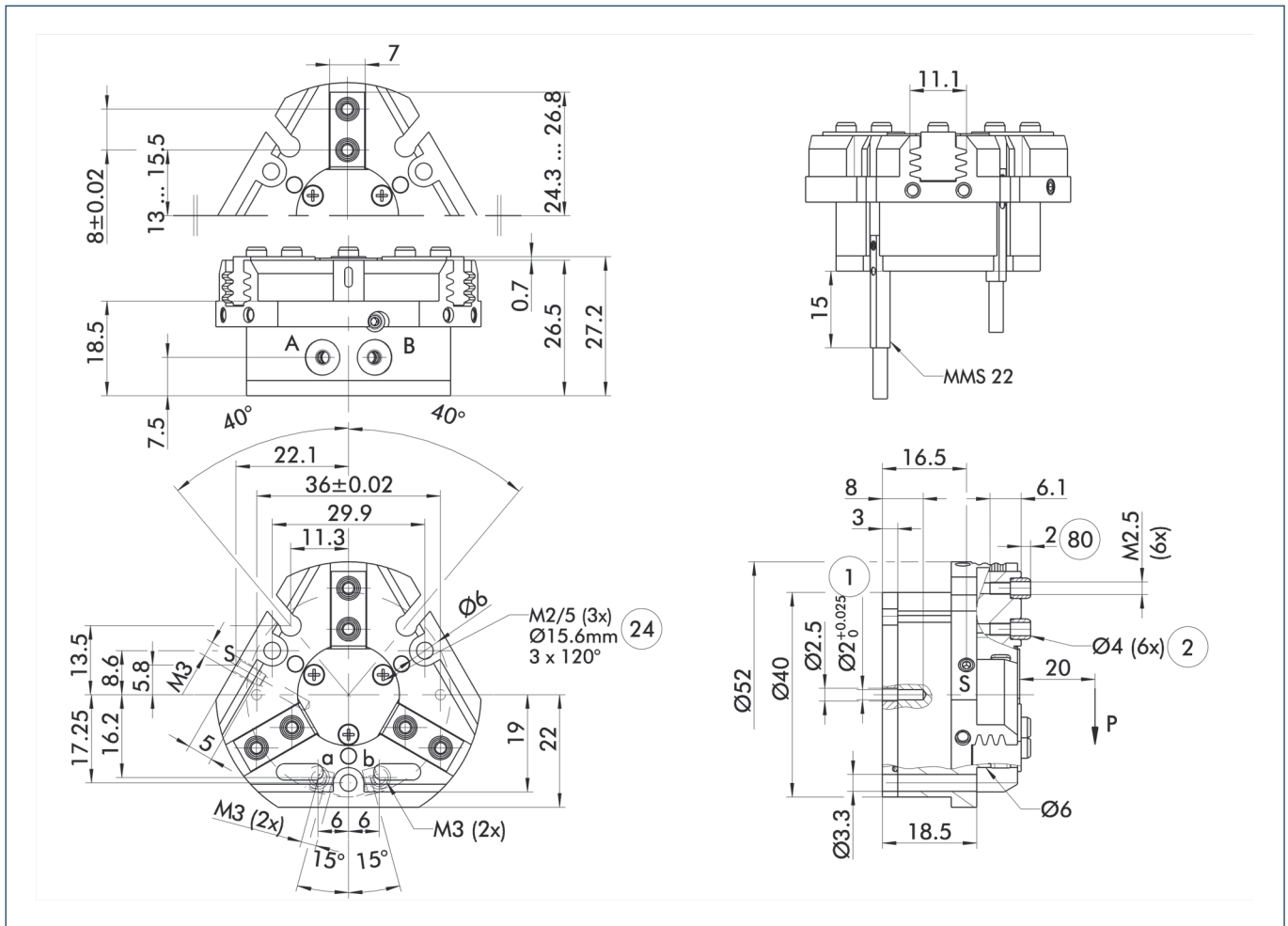

The drawing shows the gripper in the basic version with closed jaws, the dimensions do not include the options described below.

① The SDV-P pressure maintenance valve can also be used for I.D. or O.D. gripping alternatively or in addition to the spring-loaded, mechanical gripping force maintenance device (see "Accessories" catalog section).

- A, a Main/direct connection, gripper opening
- B, b Main/direct connection, gripper closing
- S Air purge connection
- ① Gripper connection
- ② Finger connection

- ②④ Bolt circle
- ⑧⑩ Depth of the centering sleeve hole in the matching part

## Hose-free direct connection

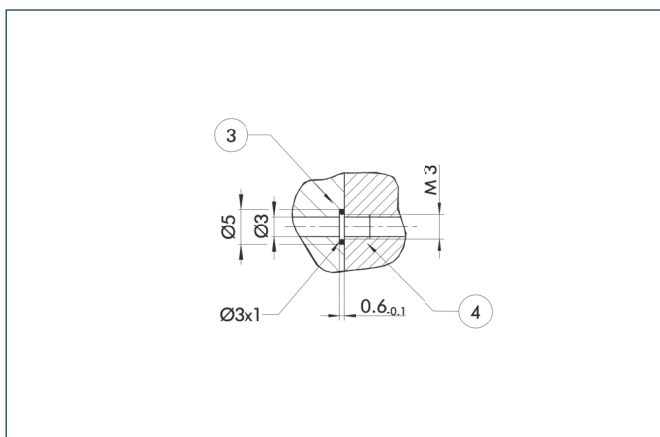

- ③ Adapter
- ④ Gripper

The direct connection is used for supplying compressed air without hoses. Instead, the pressure medium is fed through bore-holes in the mounting plate.

## AS/IS gripping force maintenance device

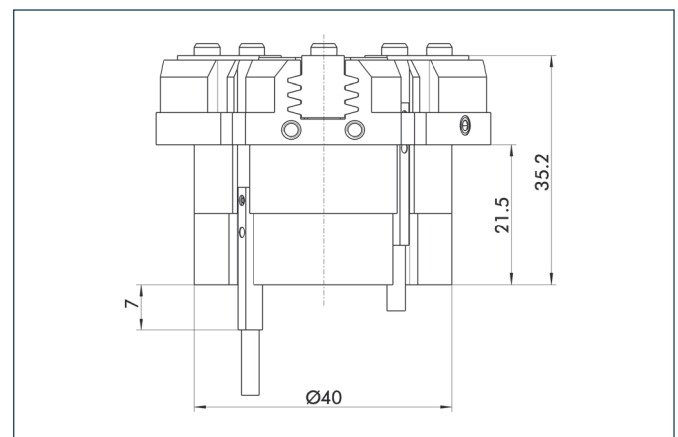

The mechanical gripping force maintenance device ensures a minimum gripping force even in case of pressure drop. This acts as closing force in the AS version, and as opening force in the IS version. In addition, the gripping force maintenance device can also be used for increasing the gripping force or for single-acting gripping.

# PZN-plus 40

Pneumatic • 3-Finger Centric Gripper • Universal Gripper

## Dust-protection version

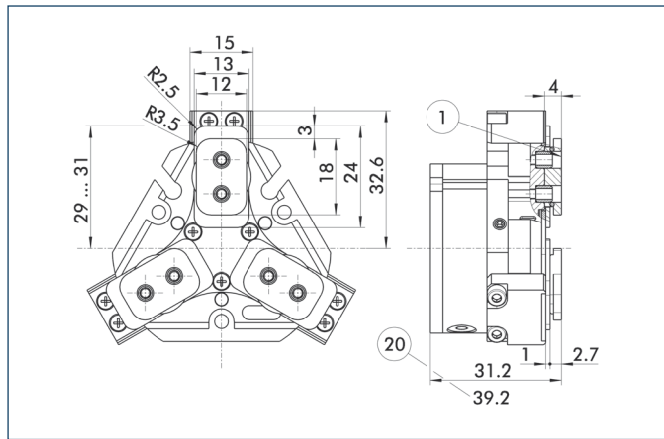

- ① Gripper connection
- ②⑩ For AS / IS version

The "dust-protection" option increases the degree of protection against penetrating substances. The screw connection diagram shifts by the height of the intermediate jaw. The finger length is still measured from the upper edge of the gripper housing.

## Precision version

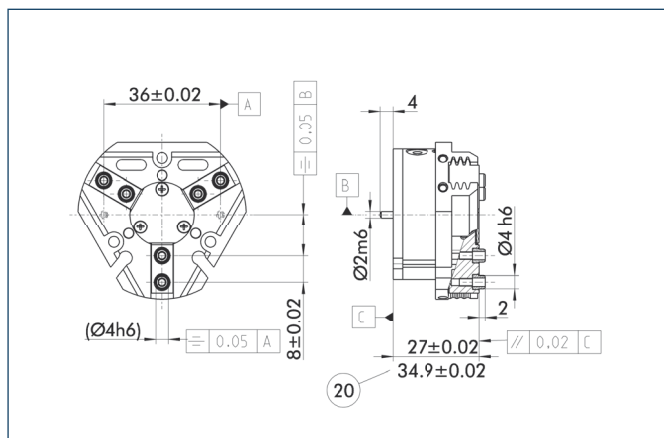

- ②⑩ For AS / IS version

The indicated tolerances just refer to the types of precision versions shown in the chart of technical specifications. All other types of precision versions are available on request.

## Force intensified version

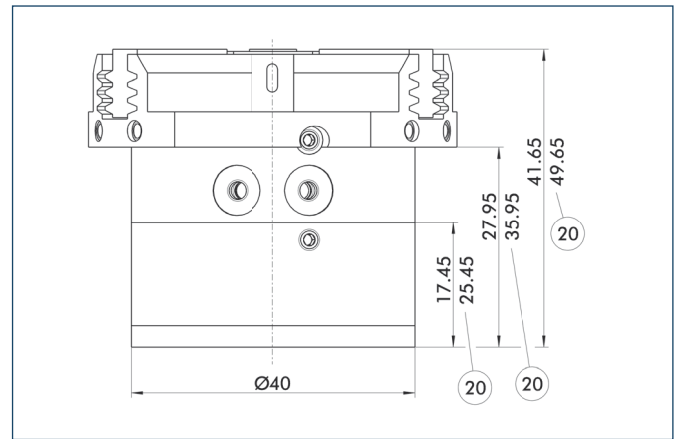

- ②⑩ For AS / IS version

The KVZ cylinder increases the gripping forces during opening and closing. A second, in series-connected piston also increases the force on the wedge hook. The full gripping force shown in the data table is sometimes only reached after a few hundred gripping cycles. Please consider that grippers which are equipped with a gripping force maintenance device (AS / IS) are higher.

## Modular Assembly Automation

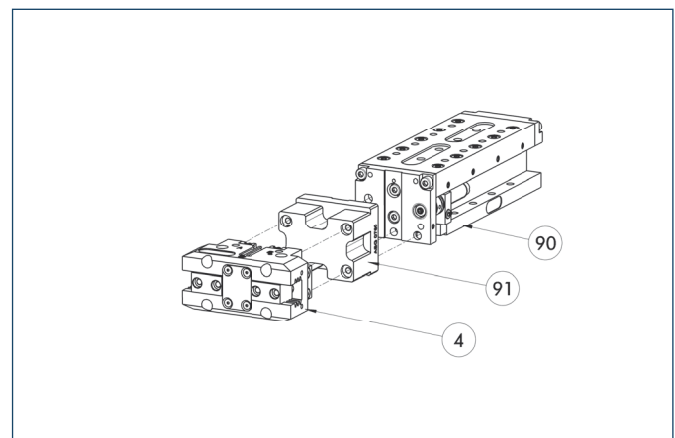

- ④ Gripper
- ⑨⑩ CLM
- ⑨① ASG

This gripper can be combined with the standard linear modules LM, KLM, CLM and ELM of the GEMOTEC modular system. For more information see our main catalog "Modular Assembly Automation".

### Spring-loaded pressure piece

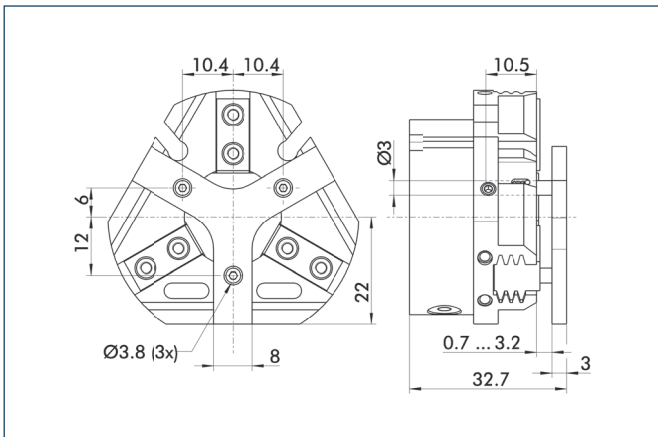

For spring-supported positioning of the workpiece against a stop after the gripper has opened. Especially developed for loading machines.

Description	ID	Stroke	Min. force
Spring-loaded pressure piece			
A-PZN-plus 40	0303718	2.5 mm	5 N

### Protection cover

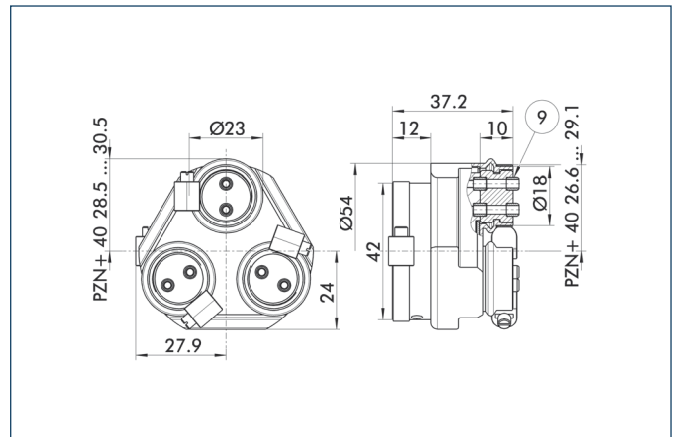

⑨ For mounting screw connection diagram, see basic version

The HUE protective cover completely protects the gripper against external influences up to IP65 if an additional sealing of the cover bottom is provided as part of the application. The mounting diagram shifts by the height of the intermediate jaw.

Description	ID	Cleanroom class ISO-classification 14644-1
Protection cover		
HUE PZN-plus 40	0303478	2

### Universal intermediate jaw

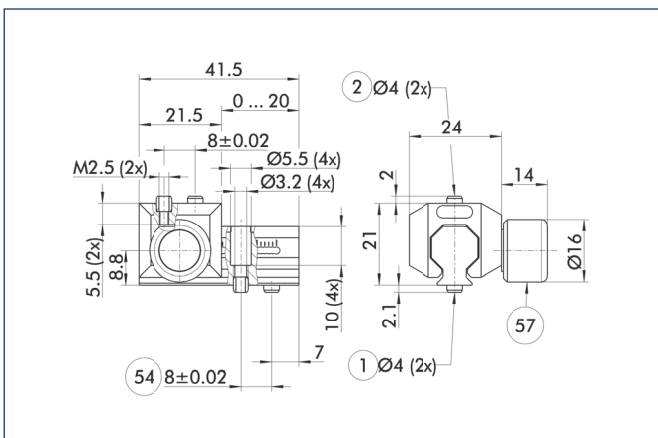

- ① Gripper connection
- ② Finger connection
- ⑤④ Optional right or left connection
- ⑤⑦ Locking

The universal intermediate jaw allows fast tool-free and reliable plugging and shifting of top jaws at the gripper.

Description	ID	Grid dimension
Universal intermediate jaw		
UZB 40	0300040	1 mm

① The slide UZB-S can be removed completely and has to be ordered separately. Moreover, it allows a fast jaw change.

### Finger blanks

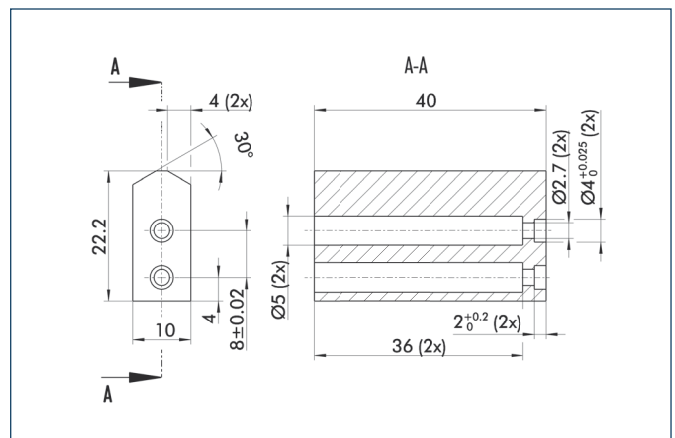

Finger blanks for customized subsequent machining

Description	ID	Material	Scope of delivery
Finger blanks			
ABR-plus 40	0300008	Aluminum	1
SBR-plus 40	0300018	16 MnCr 5	1



## Compensation unit with spring reset

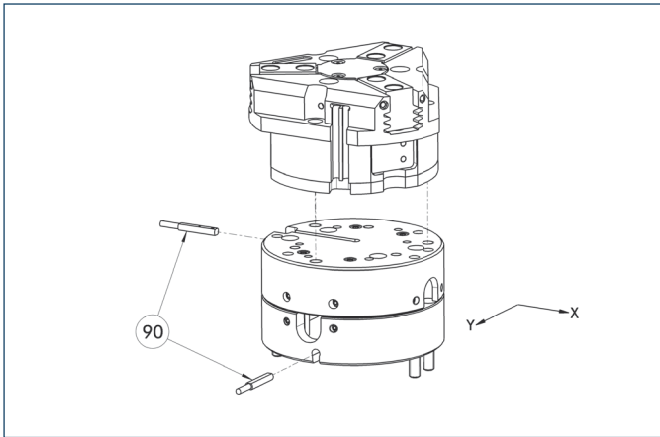

### 90 Monitoring

Grippers can be directly mounted without using an adapter plate. For details see our catalog "Robot Accessories".

Description	ID	Compensation travel	Reset force
<b>Compensation unit</b>			
AGE-F-XY-031-1	<b>0324900</b>	±1.5 mm	1 N
AGE-F-XY-031-2	<b>0324901</b>	±1.5 mm	2.5 N
AGE-F-XY-031-3	<b>0324902</b>	±1.5 mm	3.3 kN

## Programmable magnetic switch

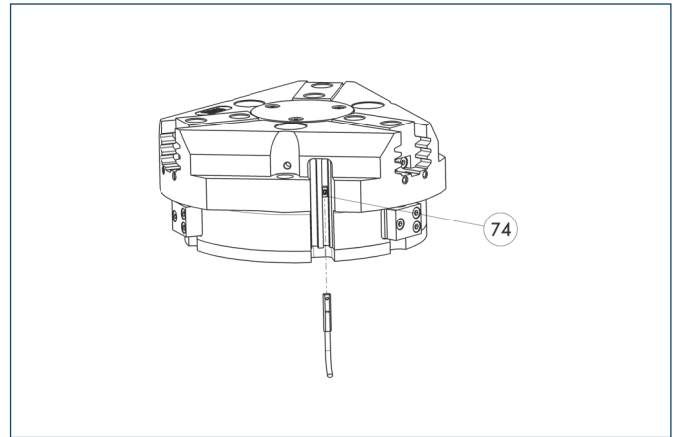

### 74 Stop for MMS-P

Position monitoring with two programmable positions per sensor. The end position monitoring is mounted in the C-slot.

Description	ID	Recommended product
<b>Programmable magnetic switch</b>		
MMS-P 22-S-M8-PNP	<b>0301370</b>	•
MMSK-P 22-S-PNP	<b>0301371</b>	
<b>Connection cables</b>		
KA BG08-L 4P-0500	<b>0307767</b>	
KA BG08-L 4P-1000	<b>0307768</b>	
KA BW08-L 4P-0500	<b>0307765</b>	
KA BW08-L 4P-1000	<b>0307766</b>	
<b>Sensor Distributor</b>		
V2-M8-4P-2XM8-3P	<b>0301380</b>	

- ① Please note the minimum permitted bending radii for the sensor cables, which are generally 35 mm.
- ① Per gripper one sensor (closer/NO) is required, optionally a cable extension.

## Electronic magnetic switches

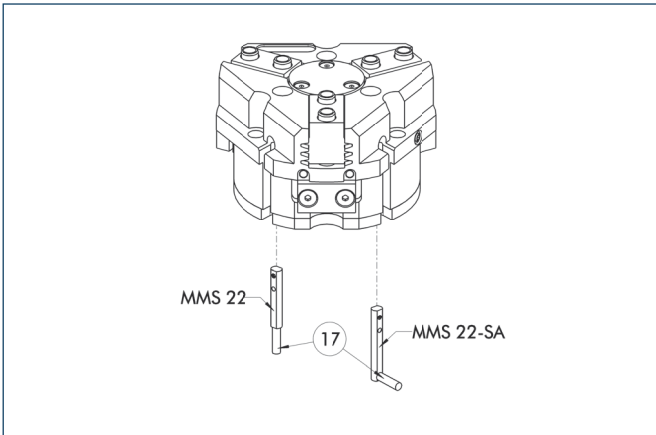

17 Cable outlet

End position monitoring for mounting in the C-slot

Description	ID	Recommended product
<b>Electronic magnetic switches</b>		
MMS 22-S-M5-PNP	0301438	
MMS 22-S-M5-NPN	0301439	
MMS 22-S-M8-PNP	0301432	•
MMS 22-S-M8-NPN	0301433	
MMSK 22-S-PNP	0301434	
MMSK 22-S-NPN	0301435	
<b>Electronic magnetic switches with lateral cable outlet</b>		
MMS 22-S-M5-PNP-SA	0301448	
MMS 22-S-M5-NPN-SA	0301449	
MMS 22-S-M8-PNP-SA	0301442	•
MMS 22-S-M8-NPN-SA	0301443	
MMSK 22-S-PNP-SA	0301444	
MMSK 22-S-NPN-SA	0301445	
<b>Connection cables</b>		
KA BG05-L 3P-0300	0301652	
KA BG08-L 3P-0300-PNP	0301622	
KA BG08-L 3P-0500-PNP	0301623	
KA BW05-L 3P-0300	0301650	
KA BW08-L 3P-0300-NPN	0301602	
KA BW08-L 3P-0300-PNP	0301594	
KA BW08-L 3P-0500-NPN	9641116	
KA BW08-L 3P-0500-PNP	0301502	
<b>Cable extensions</b>		
KV BW08-SG08 3P-0030-PNP	0301495	
KV BW08-SG08 3P-0100-PNP	0301496	
KV BW08-SG08 3P-0200-PNP	0301497	

① Two sensors (closer/NO) are required for each gripper, plus extension cables as an option.

① Please note the minimum permitted bending radii for the sensor cables, which are generally 35 mm.



You can find more detailed information and individual parts of the above-mentioned accessories in the "Accessories" catalog section.

# PZN-plus 50

Pneumatic • 3-Finger Centric Gripper • Universal Gripper



## Gripping force, I.D. gripping

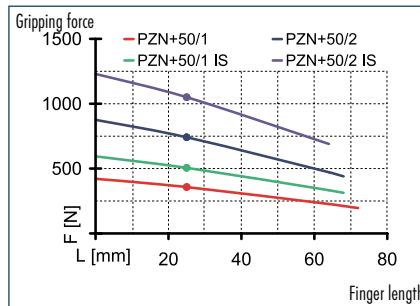

## Gripping force, O.D. gripping

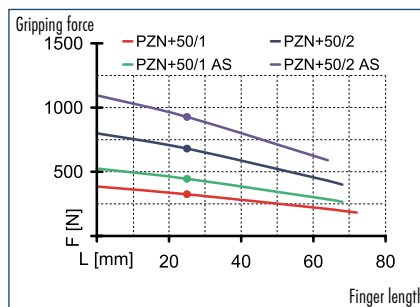

## Finger load

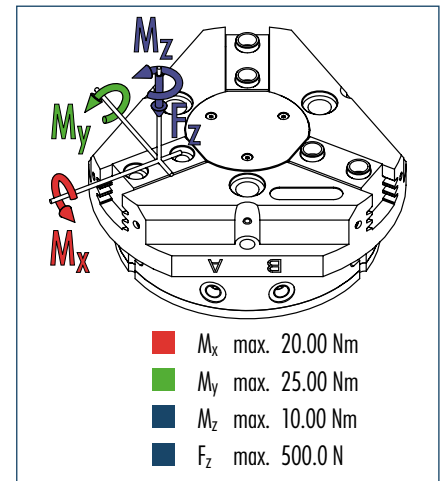

① The indicated moments and forces are static values, apply per base jaw and may occur simultaneously.  $M_y$  may arise in addition to the moment generated by the gripping force itself. If the max. permitted finger weight is exceeded, it is imperative to throttle the air pressure so that the jaw movement occurs without any hitting or bouncing. Service life may be reduced.

## Technical data

Description	PZN-plus 50-1	PZN-plus 50-2	PZN-plus 50-1-AS	PZN-plus 50-2-AS	PZN-plus 50-1-IS	PZN-plus 50-2-IS
ID	0303309	0303409	0303509	0303609	0303539	0303639
Stroke per finger [mm]	4	2	4	2	4	2
Closing force [N]	325	680	445	925		
Opening force [N]	355	740			505	1050
Min. spring force [N]			120	245	150	310
Weight [kg]	0.27	0.27	0.35	0.35	0.35	0.35
Recommended workpiece weight [kg]	1.65	3.4	1.65	3.4	1.65	3.4
Air consumption per double stroke [cm <sup>3</sup> ]	9	9	18	18	18	18
Min./max. operating pressure [bar]	2/8	2/8	4/6.5	4/6.5	4/6.5	4/6.5
Nominal operating pressure [bar]	6	6	6	6	6	6
Closing/opening time [s]	0.03/0.03	0.03/0.03	0.02/0.04	0.02/0.04	0.04/0.02	0.04/0.02
Max. permitted finger length [mm]	72	68	68	68	64	64
Max. permitted weight per finger [kg]	0.18	0.18	0.18	0.18	0.18	0.18
IP class	40	40	40	40	40	40
Min./max. ambient temperature [°C]	-10/90	-10/90	-10/90	-10/90	-10/90	-10/90
Repeat accuracy [mm]	0.01	0.01	0.01	0.01	0.01	0.01
Cleanroom class						
ISO-classification 14644-1	5	5	5	5	5	5

## OPTIONS and their characteristics

Dust-protection version	37303309	37303409	37303509	37303609	37303539	37303639
IP class	64	64	64	64	64	64
Weight [kg]	0.33	0.33	0.41	0.41	0.41	0.41
Anti-corrosion version	38303309	38303409	38303509	38303609	38303539	38303639
High-temperature version	39303309	39303409	39303509	39303609	39303539	39303639
Min./max. ambient temperature [°C]	-10/130	-10/130	-10/130	-10/130	-10/130	-10/130
Force intensified version	PZN-plus 50-1-KVZ	PZN-plus 50-2-KVZ	PZN-plus 50-1-AS-KVZ		PZN-plus 50-1-IS-KVZ	
ID	0372200	0372210	0372220		0372240	
Closing force [N]	520	1090	640			
Opening force [N]	570	1185			720	
Weight [kg]	0.38	0.38	0.46		0.46	
Maximum pressure [bar]	8	8	6		6	
Max. permitted finger length [mm]	64	50	50		50	
Precision version	0303339	0303439	0303489	0303589		

## Main view

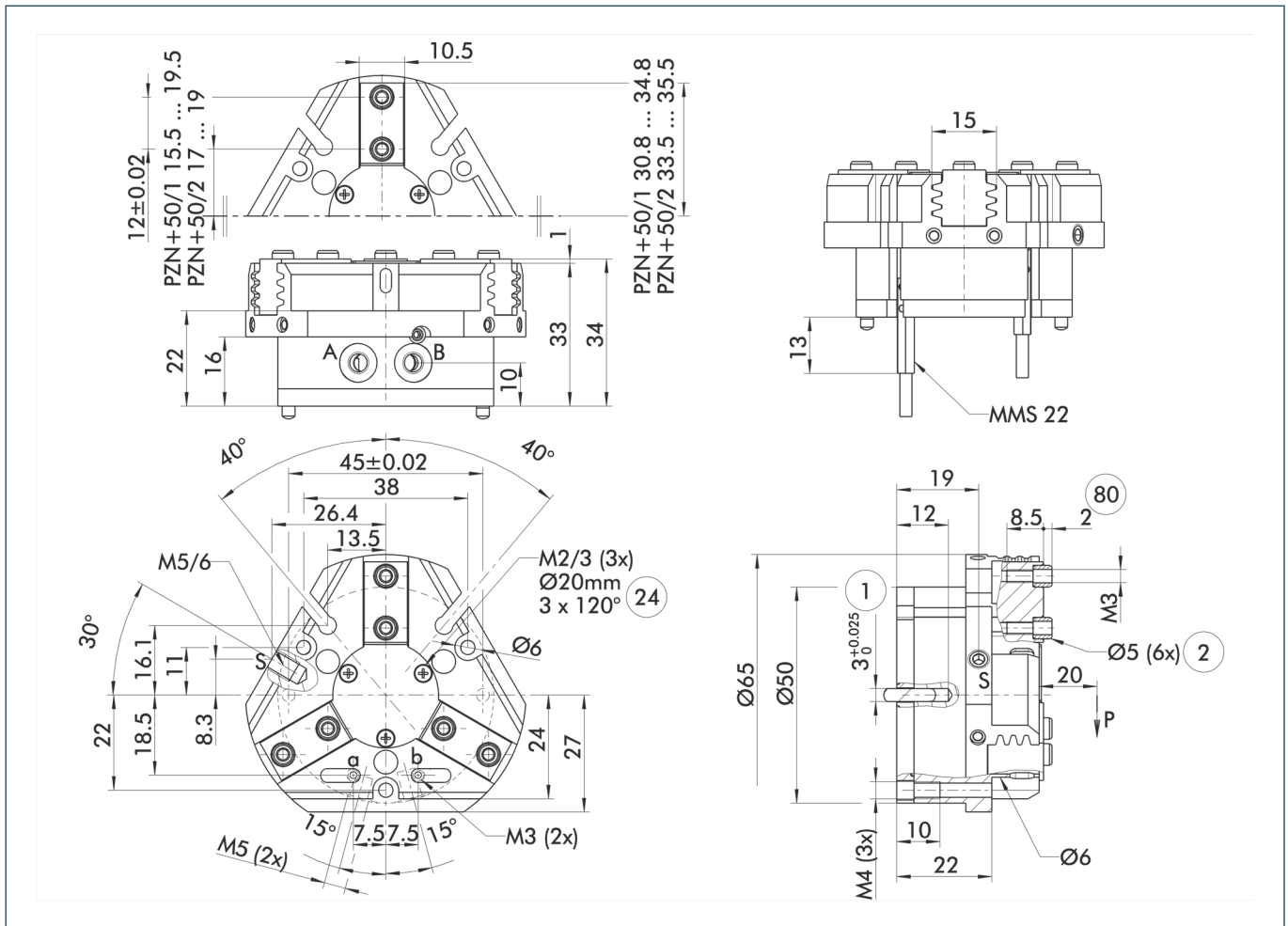

The drawing shows the gripper in the basic version with closed jaws, the dimensions do not include the options described below.

① The SDV-P pressure maintenance valve can also be used for I.D. or O.D. gripping alternatively or in addition to the spring-loaded, mechanical gripping force maintenance device (see "Accessories" catalog section).

- A, a Main/direct connection, gripper opening
- B, b Main/direct connection, gripper closing
- S Air purge connection
- ① Gripper connection
- ② Finger connection
- ②④ Bolt circle
- ⑧⑩ Depth of the centering sleeve hole in the matching part

## Hose-free direct connection

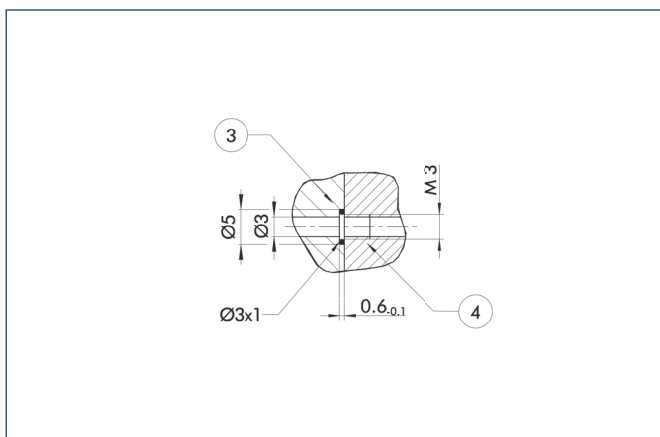

- ③ Adapter
- ④ Gripper

The direct connection is used for supplying compressed air without hoses. Instead, the pressure medium is fed through bore-holes in the mounting plate.

## AS/IS gripping force maintenance device

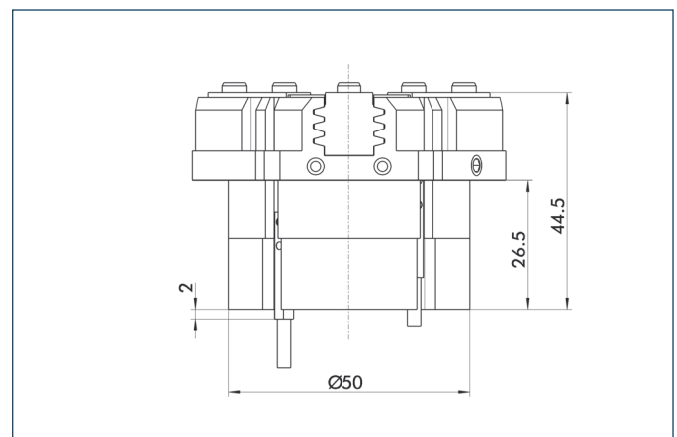

The mechanical gripping force maintenance device ensures a minimum gripping force even in case of pressure drop. This acts as closing force in the AS version, and as opening force in the IS version. In addition, the gripping force maintenance device can also be used for increasing the gripping force or for single-acting gripping.

# PZN-plus 50

Pneumatic • 3-Finger Centric Gripper • Universal Gripper

## Dust-protection version

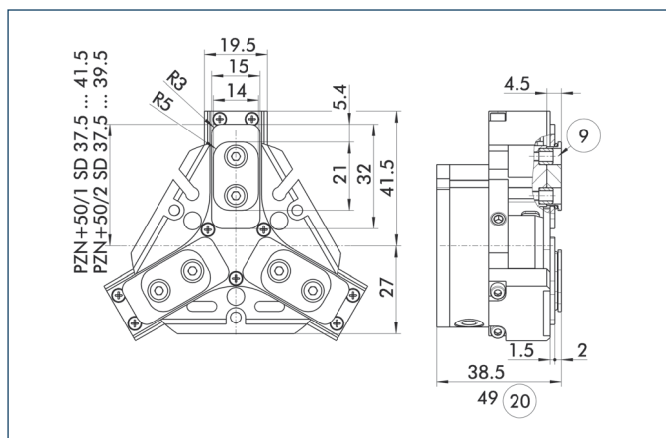

⑨ For mounting screw connection diagram, see basic version ⑳ For AS / IS version

The "dust-protection" option increases the degree of protection against penetrating substances. The screw connection diagram shifts by the height of the intermediate jaw. The finger length is still measured from the upper edge of the gripper housing.

## Precision version

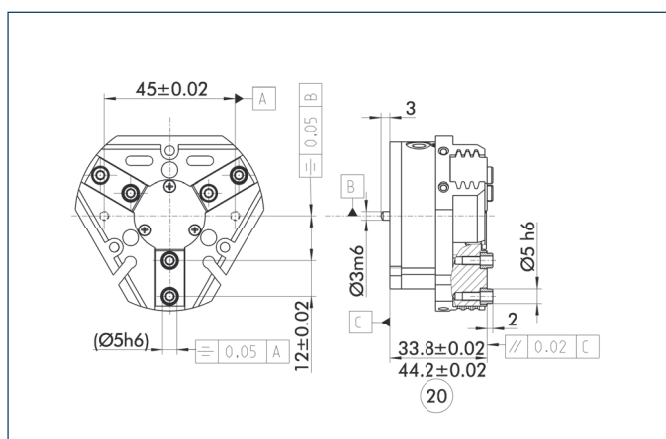

⑳ For AS / IS version

The indicated tolerances just refer to the types of precision versions shown in the chart of technical specifications. All other types of precision versions are available on request.

## Force intensified version

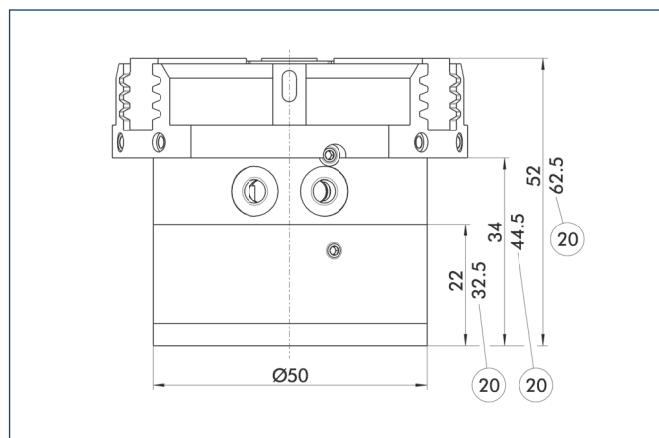

⑳ For AS / IS version

The KVZ cylinder increases the gripping forces during opening and closing. A second, in series-connected piston also increases the force on the wedge hook. The full gripping force shown in the data table is sometimes only reached after a few hundred gripping cycles. Please consider that grippers which are equipped with a gripping force maintenance device (AS / IS) are higher.

## Modular Assembly Automation

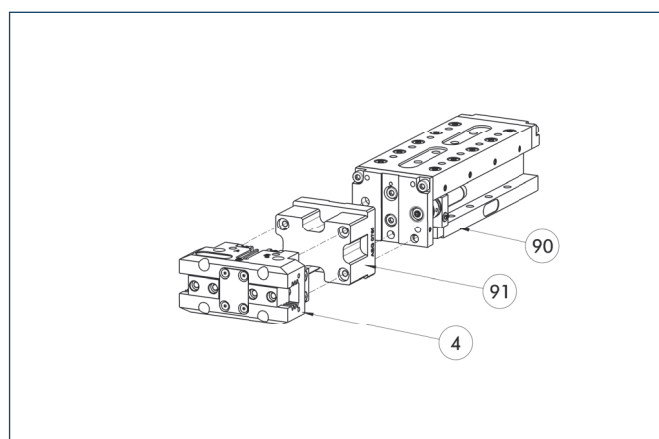

④ Gripper  
⑨⑩ CLM

⑨① ASG

This gripper can be combined with the standard linear modules LM, KLM, CLM and ELM of the GEMOTEC modular system. For more information see our main catalog "Modular Assembly Automation".

### Spring-loaded pressure piece

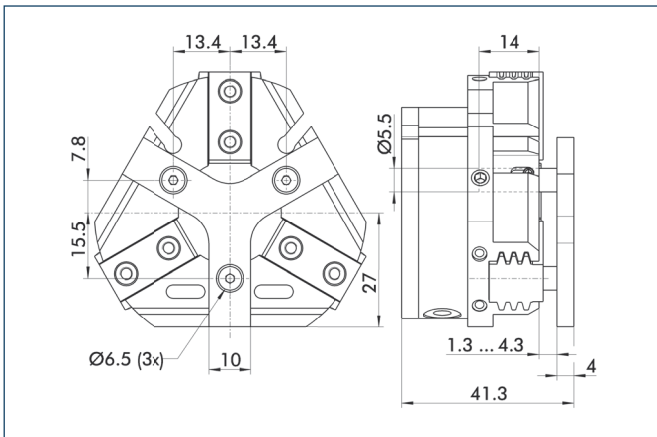

For spring-supported positioning of the workpiece against a stop after the gripper has opened. Especially developed for loading machines.

Description	ID	Stroke	Min. force
Spring-loaded pressure piece			
A-PZN-plus 50	0303719	3 mm	12 N

① The pressure piece cannot be combined with the dust-protection version. Please contact us if you require a special pressure piece.

### Quick-change Jaw System

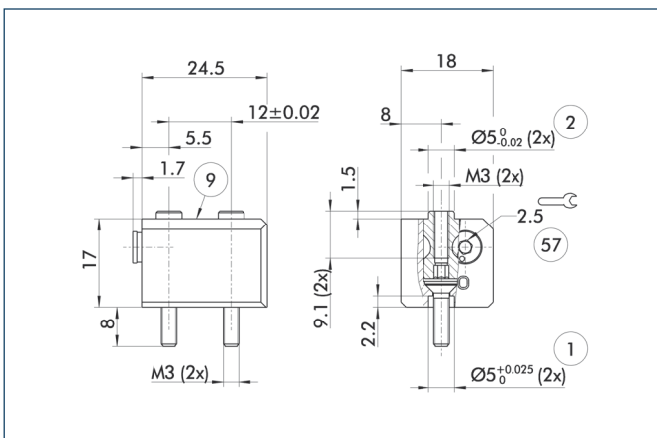

- ① Gripper connection
- ② Finger connection
- ⑨ For mounting screw connection diagram, see basic version
- ⑤⑦ Locking

The BSWs quick-change jaw system enables top jaws to be changed on the gripper manually and rapidly. An adapter (BSWS-A) and a base (BSWS-B) are required for each gripper jaw.

For a reverse assembly without height set-up, one adapter (BSWS-A) and a kit (BSWS-U) per gripper jaw are required. Another effect of the BSWs-U is, that there are no disturbing fastening bores in the finger contour.

Description	ID
Quick-change Jaw System adapter	
BSWS-A 50	0303020
Quick-change Jaw System base	
BSWS-B 50	0303021
Quick-change Jaw System reversed	
BSWS-U 50	0303040

### Protection cover

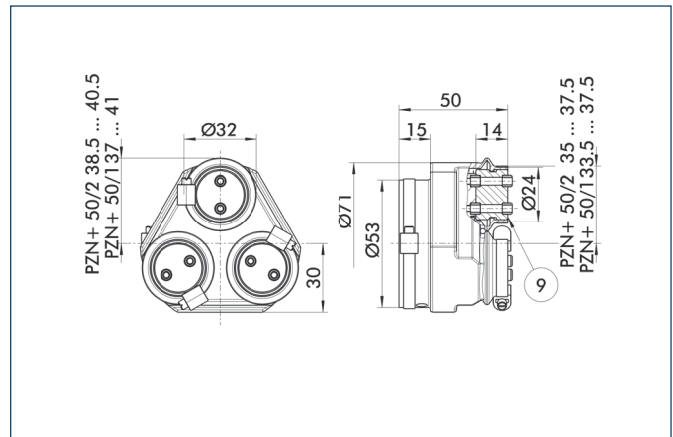

⑨ For mounting screw connection diagram, see basic version

The HUE protective cover completely protects the gripper against external influences up to IP65 if an additional sealing of the cover bottom is provided as part of the application. The mounting diagram shifts by the height of the intermediate jaw.

Description	ID	Cleanroom class ISO-classification 14644-1
Protection cover		
HUE PZN-plus 50	0303479	2

### Universal intermediate jaw

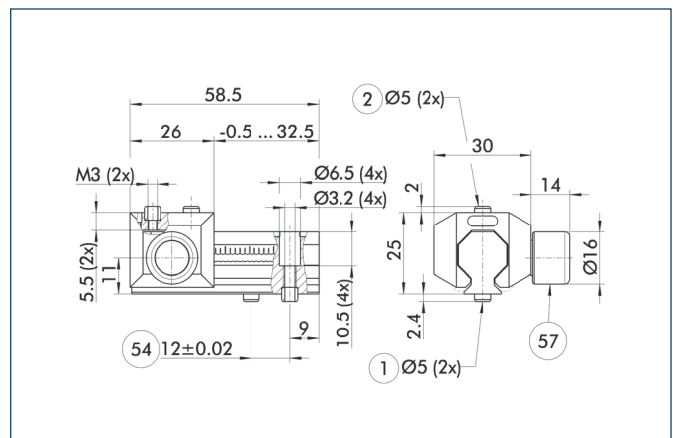

- ① Gripper connection
- ② Finger connection
- ⑤④ Optional right or left connection
- ⑤⑦ Locking

The universal intermediate jaw allows fast tool-free and reliable plugging and shifting of top jaws at the gripper.

Description	ID	Grid dimension
Universal intermediate jaw		
UZB 50	0300041	1.5 mm

① The slide UZB-S can be removed completely and has to be ordered separately. Moreover, it allows a fast jaw change.



You can find more detailed information and individual parts of the above-mentioned accessories in the "Accessories" catalog section.

## Force measuring jaws

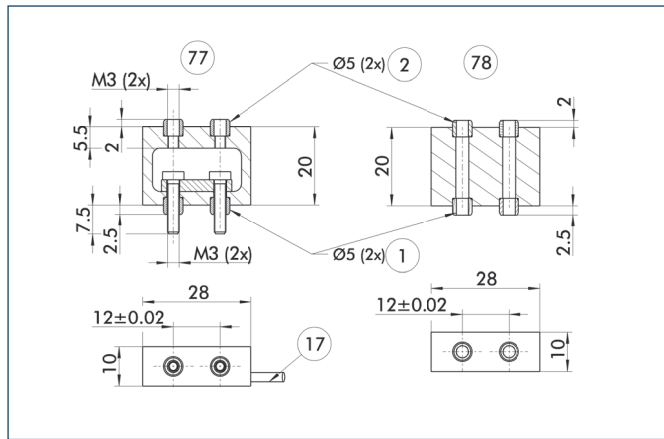

- ① Gripper connection
- ② Finger connection
- ⑦ Active intermediate jaws
- ⑧ Passive intermediate jaws
- ⑰ Cable outlet

Force measuring jaws measure gripping forces, but can also determine workpiece weights or dimensional deviations. There are active and passive intermediate jaws (FMS-ZBA or FMS-ZBP). At least one active force measuring jaw is required per gripper, the rest can be passive. For each active jaw, a FMS-A1 control unit and a FMS-A connection cable are required.

Description	ID
<b>Active intermediate jaws</b>	
FMS-ZBA 50	0301830
<b>Passive intermediate jaws</b>	
FMS-ZBP 50	0301831
<b>Electronic Processor</b>	
FMS-A1	0301810
<b>Connection cables</b>	
FMS-AK0200	0301820
FMS-AK0500	0301821
FMS-AK1000	0301822
FMS-AK2000	0301823

## Finger blanks

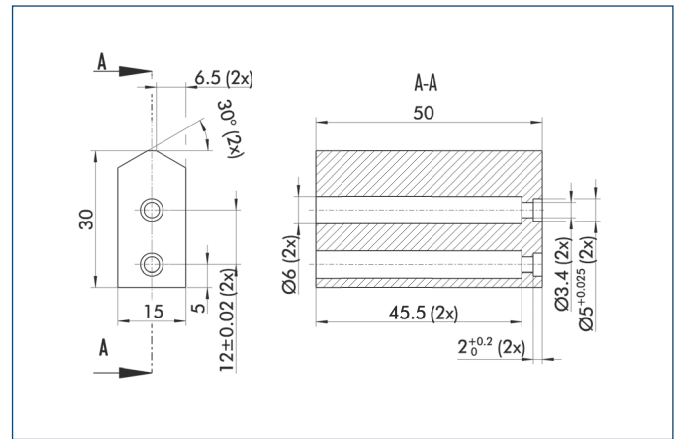

Finger blanks for customized subsequent machining

Description	ID	Material	Scope of delivery
<b>Finger blanks</b>			
ABR-plus 50	0300009	Aluminum	1
SBR-plus 50	0300019	16 MnCr 5	1

### Tolerance compensation unit

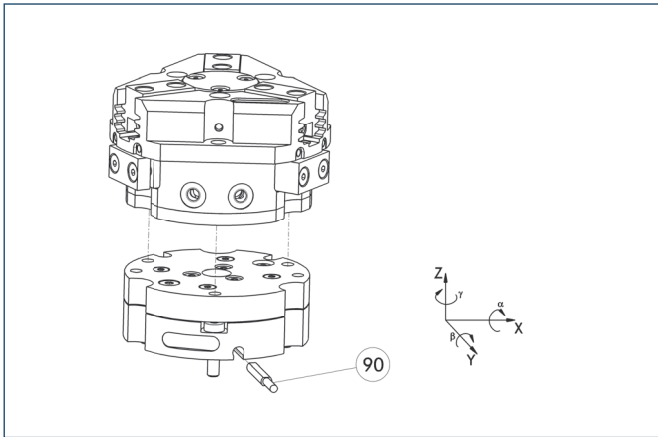

90 Monitoring of locking

Grippers can be directly mounted without an adapter plate. Tolerance compensation unit and gripper have an identical screw connection diagram. Therefore the tolerance compensation units can be assembled later. Please consider the additional assembly height of the tolerance compensation unit. For details see catalog "Robot Accessories".

Description	ID	Locking	Deflection
Compensation unit			
TCU-050-3-0V-Z	0324749	No	

### Compensation unit with spring reset

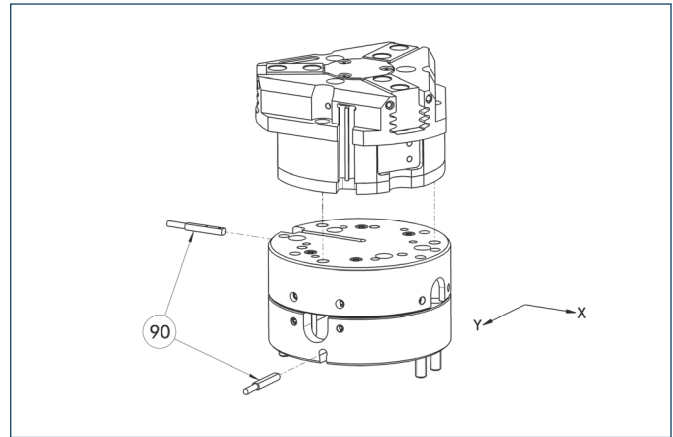

90 Monitoring

Grippers can be directly mounted without using an adapter plate. For details see our catalog "Robot Accessories".

Description	ID	Compensation travel	Reset force
Compensation unit			
AGE-F-XY-040-1	0324920	±2 mm	1 N
AGE-F-XY-040-2	0324921	±2 mm	2.5 N
AGE-F-XY-040-3	0324922	±2 mm	3.3 N

### Programmable magnetic switch

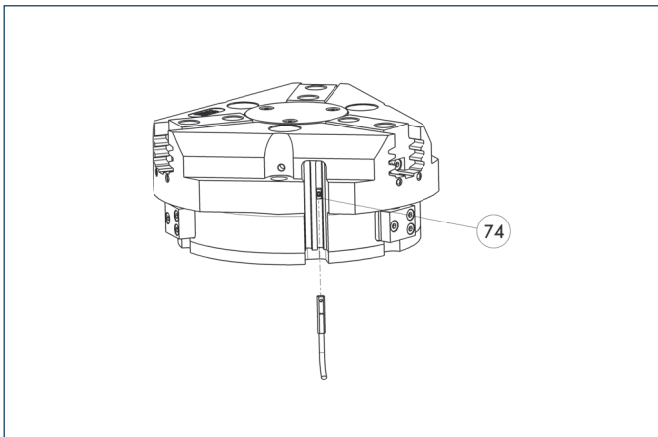

74 Stop for MMS-P

Position monitoring with two programmable positions per sensor. The end position monitoring is mounted in the C-slot.

Description	ID	Recommended product
Programmable magnetic switch		
MMS-P 22-S-M8-PNP	0301370	•
MMSK-P 22-S-PNP	0301371	
Connection cables		
KA BG08-L 4P-0500	0307767	
KA BG08-L 4P-1000	0307768	
KA BW08-L 4P-0500	0307765	
KA BW08-L 4P-1000	0307766	
Sensor Distributor		
V2-M8-4P-2XM8-3P	0301380	

① Please note the minimum permitted bending radii for the sensor cables, which are generally 35 mm.

① Per gripper one sensor (closer/NO) is required, optionally a cable extension.



## Electronic magnetic switches

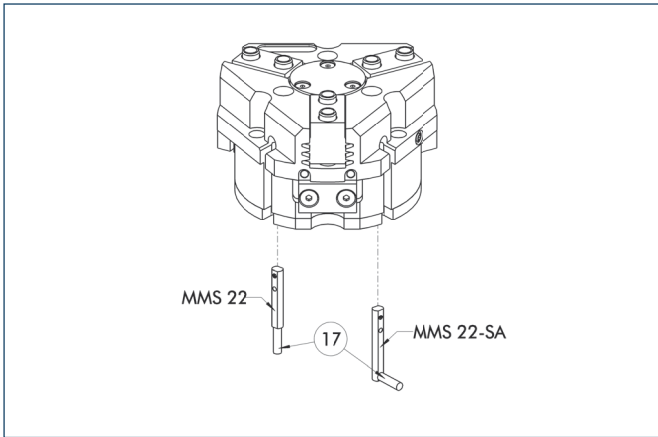

17 Cable outlet

End position monitoring for mounting in the C-slot

Description	ID	Recommended product
<b>Electronic magnetic switches</b>		
MMS 22-S-M5-PNP	0301438	
MMS 22-S-M5-NPN	0301439	
MMS 22-S-M8-PNP	0301432	•
MMS 22-S-M8-NPN	0301433	
MMSK 22-S-PNP	0301434	
MMSK 22-S-NPN	0301435	
<b>Electronic magnetic switches with lateral cable outlet</b>		
MMS 22-S-M5-PNP-SA	0301448	
MMS 22-S-M5-NPN-SA	0301449	
MMS 22-S-M8-PNP-SA	0301442	•
MMS 22-S-M8-NPN-SA	0301443	
MMSK 22-S-PNP-SA	0301444	
MMSK 22-S-NPN-SA	0301445	
<b>Connection cables</b>		
KA BG05-L 3P-0300	0301652	
KA BG08-L 3P-0300-PNP	0301622	
KA BG08-L 3P-0500-PNP	0301623	
KA BW05-L 3P-0300	0301650	
KA BW08-L 3P-0300-NPN	0301602	
KA BW08-L 3P-0300-PNP	0301594	
KA BW08-L 3P-0500-NPN	9641116	
KA BW08-L 3P-0500-PNP	0301502	
<b>Cable extensions</b>		
KV BW08-SG08 3P-0030-PNP	0301495	
KV BW08-SG08 3P-0100-PNP	0301496	
KV BW08-SG08 3P-0200-PNP	0301497	

① Two sensors (closer/NO) are required for each gripper, plus extension cables as an option.

① Please note the minimum permitted bending radii for the sensor cables, which are generally 35 mm.

You can find more detailed information and individual parts of the above-mentioned accessories in the "Accessories" catalog section.

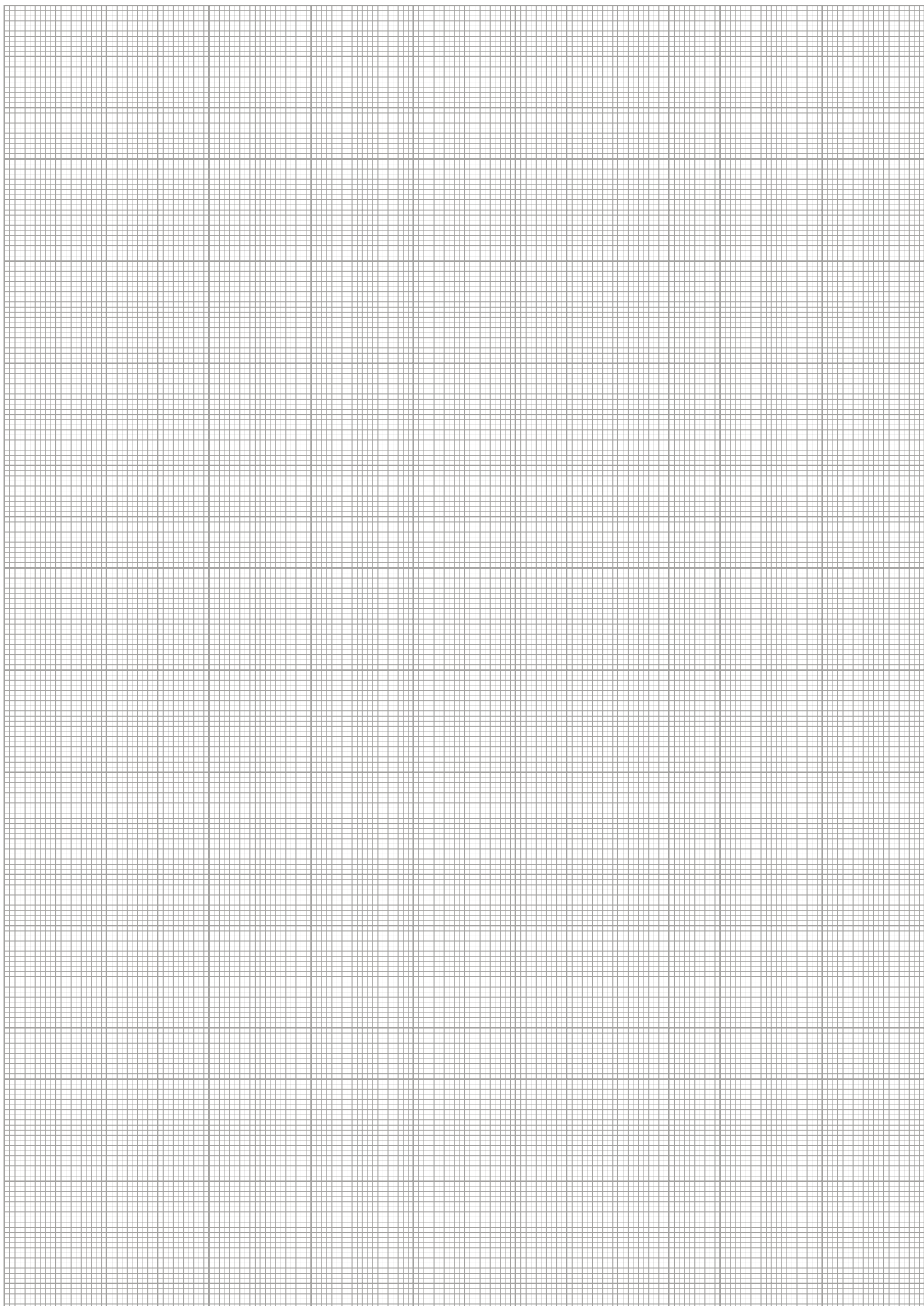

# PZN-plus 64

Pneumatic • 3-Finger Centric Gripper • Universal Gripper



## Gripping force, I.D. gripping

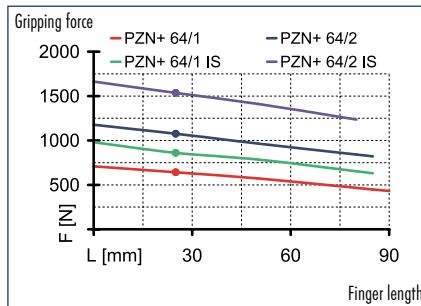

## Gripping force, O.D. gripping

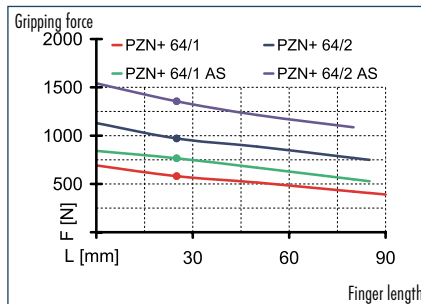

## Finger load

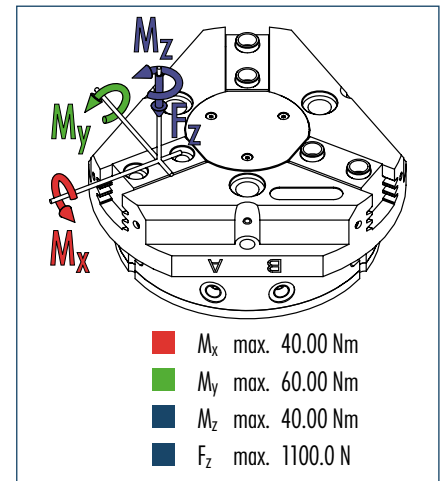

① The indicated moments and forces are static values, apply per base jaw and may occur simultaneously.  $M_y$  may arise in addition to the moment generated by the gripping force itself. If the max. permitted finger weight is exceeded, it is imperative to throttle the air pressure so that the jaw movement occurs without any hitting or bouncing. Service life may be reduced.

## Technical data

Description	PZN-plus 64-1	PZN-plus 64-2	PZN-plus 64-1-AS	PZN-plus 64-2-AS	PZN-plus 64-1-IS	PZN-plus 64-2-IS
ID	0303310	0303410	0303510	0303610	0303540	0303640
Stroke per finger [mm]	6	3	6	3	6	3
Closing force [N]	580	970	765	1285		
Opening force [N]	640	1075			860	1535
Min. spring force [N]			185	315	220	460
Weight [kg]	0.43	0.43	0.54	0.54	0.54	0.54
Recommended workpiece weight [kg]	2.9	4.85	2.9	4.85	2.9	4.85
Air consumption per double stroke [cm <sup>3</sup> ]	25	25	48	48	48	25
Min./max. operating pressure [bar]	2/8	2/8	4/6.5	4/6.5	4/6.5	4/6.5
Nominal operating pressure [bar]	6	6	6	6	6	6
Closing/opening time [s]	0.03/0.03	0.03/0.03	0.02/0.04	0.02/0.04	0.04/0.02	0.04/0.02
Max. permitted finger length [mm]	90	85	85	80	85	80
Max. permitted weight per finger [kg]	0.35	0.35	0.35	0.35	0.35	0.35
IP class	40	40	40	40	40	40
Min./max. ambient temperature [°C]	-10/90	-10/90	-10/90	-10/90	-10/90	-10/90
Repeat accuracy [mm]	0.01	0.01	0.01	0.01	0.01	0.01
Cleanroom class						
ISO-classification 14644-1	5	5	5	5	5	5

## OPTIONS and their characteristics

Dust-protection version	37303310	37303410	37303510	37303610	37303540	37303640
IP class	64	64	64	64	64	64
Weight [kg]	0.6	0.6	0.71	0.71	0.71	0.71
Anti-corrosion version	38303310	38303410	38303510	38303610	38303540	38303640
High-temperature version	39303310	39303410	39303510	39303610	39303540	39303640
Min./max. ambient temperature [°C]	-10/130	-10/130	-10/130	-10/130	-10/130	-10/130
Force intensified version	PZN-plus 64-1-KVZ	PZN-plus 64-2-KVZ	PZN-plus 64-1-AS-KVZ		PZN-plus 64-1-IS-KVZ	
ID	0372201	0372211	0372221		0372241	
Closing force [N]	1045	1745	1230			
Opening force [N]	1150	1935			1370	
Weight [kg]	0.7	0.7	0.8		0.8	
Maximum pressure [bar]	8	8	6		6	
Max. permitted finger length [mm]	80	64	64		64	
Precision version	0303340	0303440	0303490	0303590		

## Main view

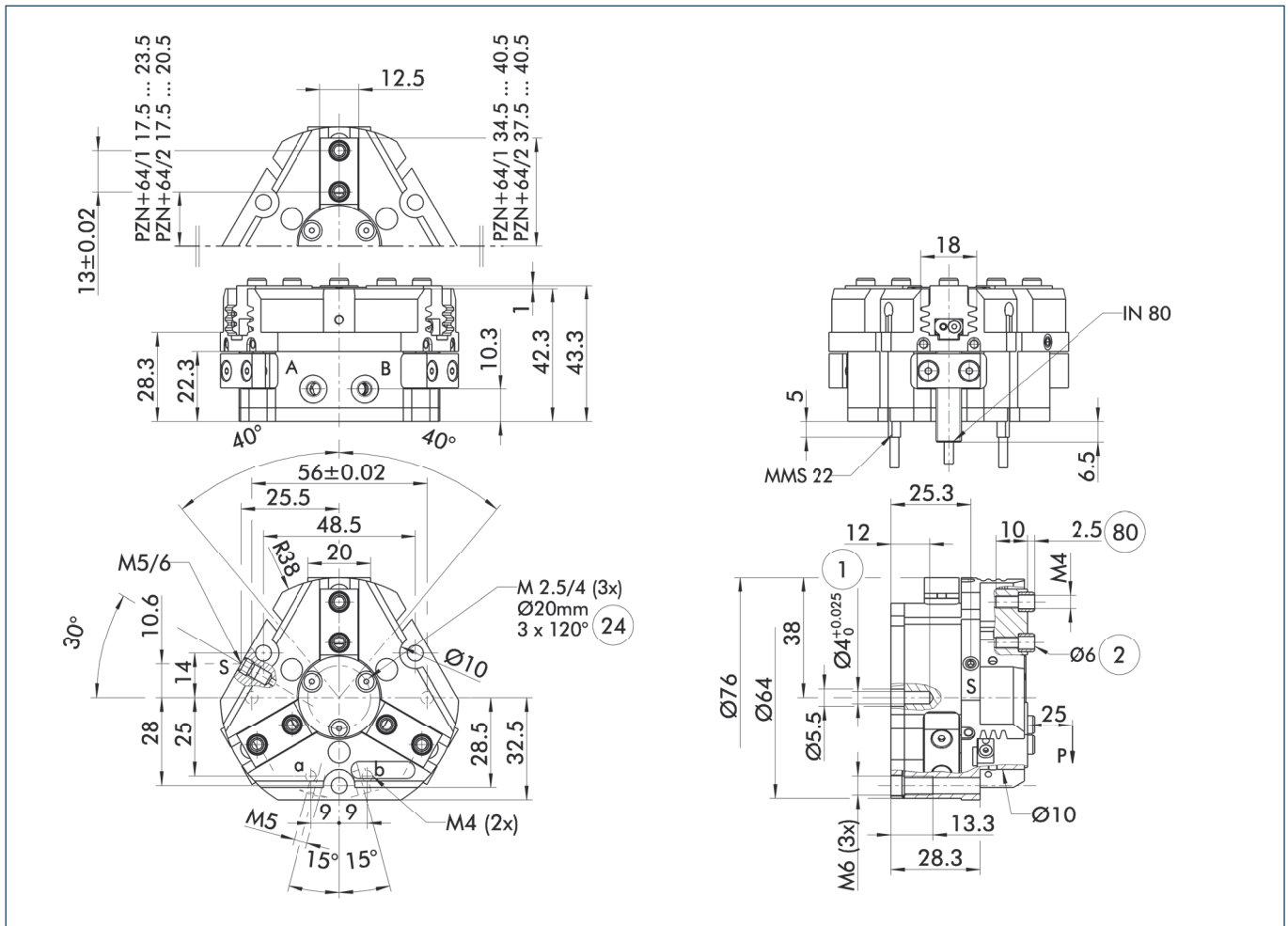

The drawing shows the gripper in the basic version with closed jaws, the dimensions do not include the options described below.

① The SDV-P pressure maintenance valve can also be used for I.D. or O.D. gripping alternatively or in addition to the spring-loaded, mechanical gripping force maintenance device (see "Accessories" catalog section).

- A, a Main/direct connection, gripper opening
- B, b Main/direct connection, gripper closing
- S Air purge connection
- ① Gripper connection
- ② Finger connection
- Ø24 Bolt circle
- Ø80 Depth of the centering sleeve hole in the matching part

## Hose-free direct connection

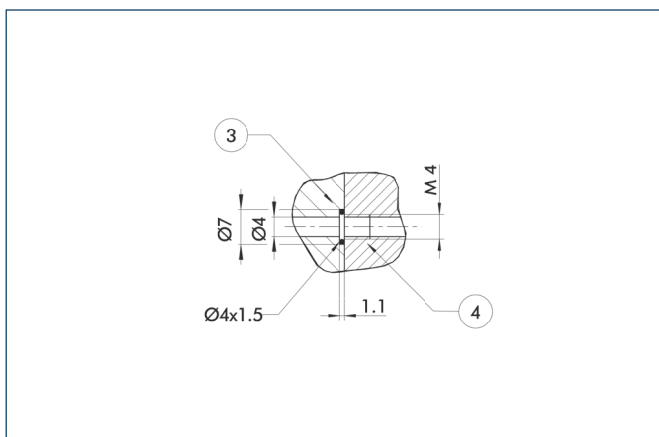

- ③ Adapter
- ④ Gripper

The direct connection is used for supplying compressed air without hoses. Instead, the pressure medium is fed through bore-holes in the mounting plate.

## AS/IS gripping force maintenance device

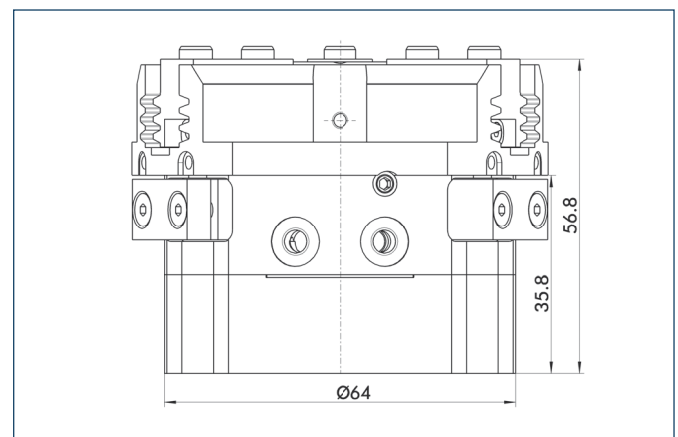

The mechanical gripping force maintenance device ensures a minimum gripping force even in case of pressure drop. This acts as closing force in the AS version, and as opening force in the IS version. In addition, the gripping force maintenance device can also be used for increasing the gripping force or for single-acting gripping.

# PZN-plus 64

Pneumatic • 3-Finger Centric Gripper • Universal Gripper

## Dust-protection version

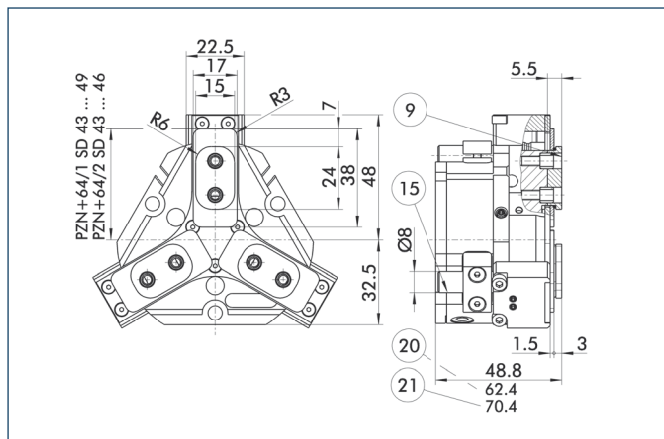

- ⑨ For mounting screw connection diagram, see basic version
- ⑩ Sealing bolt
- ⑳ For AS / IS version
- ㉑ Applies for KVZ version

The "dust-protection" option increases the degree of protection against penetrating substances. The screw connection diagram shifts by the height of the intermediate jaw. The finger length is still measured from the upper edge of the gripper housing.

## Precision version

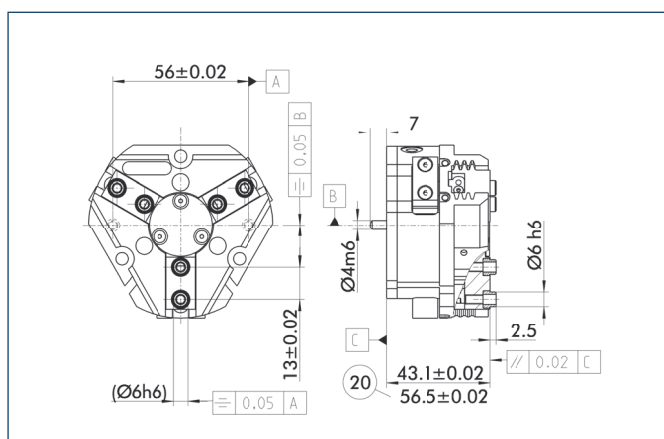

- ㉒ For AS / IS version

The indicated tolerances just refer to the types of precision versions shown in the chart of technical specifications. All other types of precision versions are available on request.

## Force intensified version

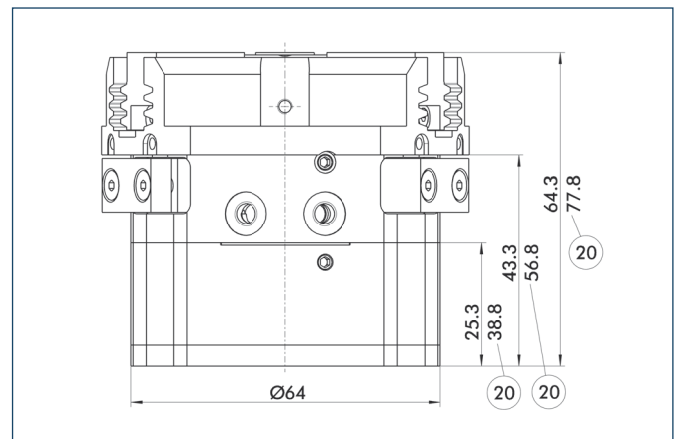

- ㉒ For AS / IS version

The KVZ cylinder increases the gripping forces during opening and closing. A second, in series-connected piston also increases the force on the wedge hook. The full gripping force shown in the data table is sometimes only reached after a few hundred gripping cycles. Please consider that grippers which are equipped with a gripping force maintenance device (AS / IS) are higher.

## Modular Assembly Automation

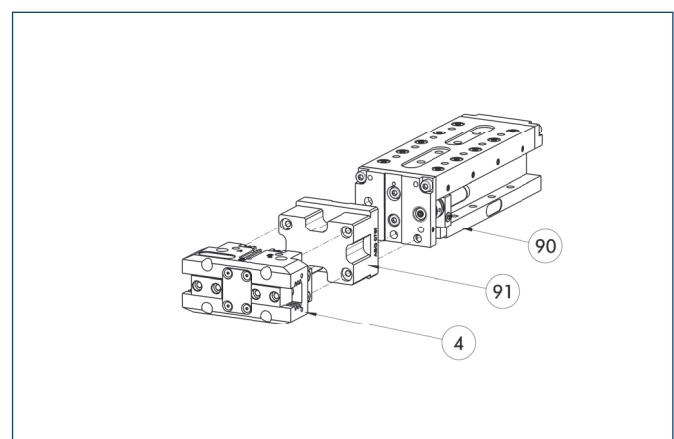

- ④ Gripper
- ⑨⑩ CLM
- ⑨① ASG

This gripper can be combined with the standard linear modules LM, KLM, CLM and ELM of the GEMOTEC modular system. For more information see our main catalog "Modular Assembly Automation".



### Force measuring jaws

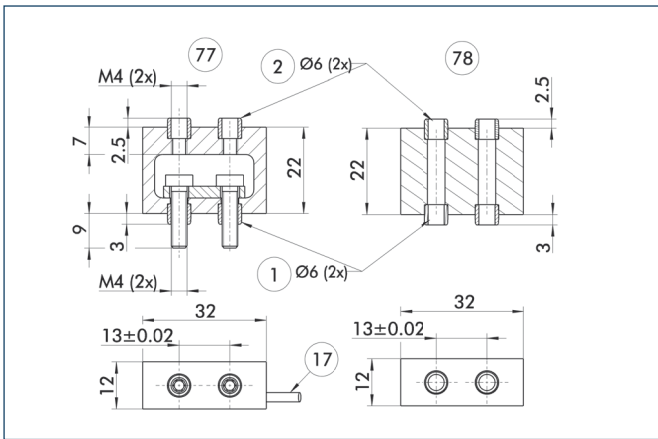

- ① Gripper connection
- ② Finger connection
- ⑦ Active intermediate jaws
- ⑧ Passive intermediate jaws
- ⑰ Cable outlet

Force measuring jaws measure gripping forces, but can also determine workpiece weights or dimensional deviations. There are active and passive intermediate jaws (FMS-ZBA or FMS-ZBP). At least one active force measuring jaw is required per gripper, the rest can be passive. For each active jaw, a FMS-A1 control unit and a FMS-A connection cable are required.

Description	ID
<b>Active intermediate jaws</b>	
FMS-ZBA 64	0301832
<b>Passive intermediate jaws</b>	
FMS-ZBP 64	0301833
<b>Electronic Processor</b>	
FMS-A1	0301810
<b>Connection cables</b>	
FMS-AK0200	0301820
FMS-AK0500	0301821
FMS-AK1000	0301822
FMS-AK2000	0301823

### Finger blanks

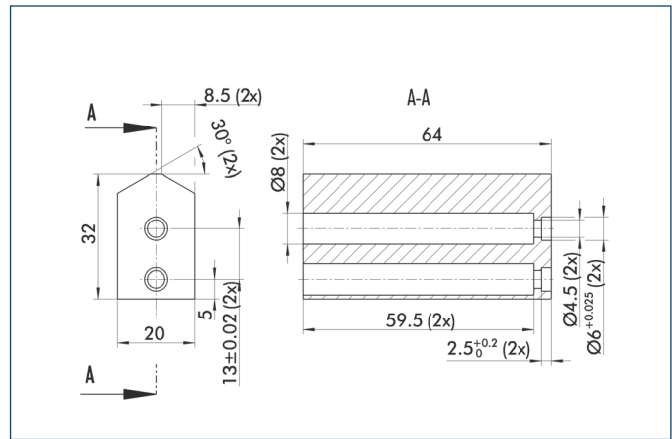

Finger blanks for customized subsequent machining

Description	ID	Material	Scope of delivery
<b>Finger blanks</b>			
ABR-plus 64	0300010	Aluminum	1
SBR-plus 64	0300020	16 MnCr 5	1

## Tolerance compensation unit

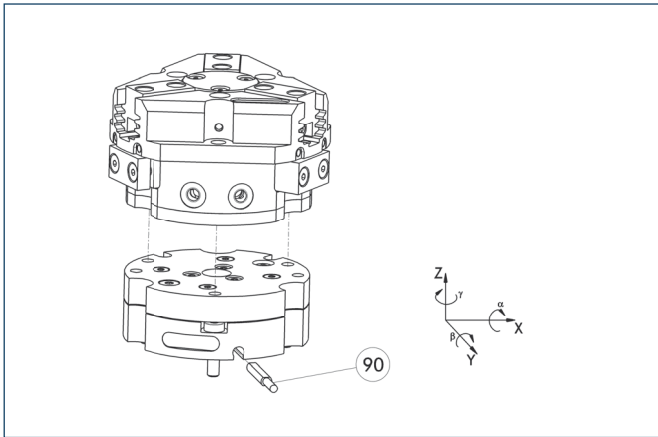

90 Monitoring of locking

Grippers can be directly mounted without an adapter plate. Tolerance compensation unit and gripper have an identical screw connection diagram. Therefore the tolerance compensation units can be assembled later. Please consider the additional assembly height of the tolerance compensation unit. For details see catalog "Robot Accessories".

Description	ID	Locking	Deflection
<b>Compensation unit</b>			
TCU-064-3-MV-Z	0324766	Yes	
TCU-064-3-OV-Z	0324767	No	

## Compensation unit with spring reset

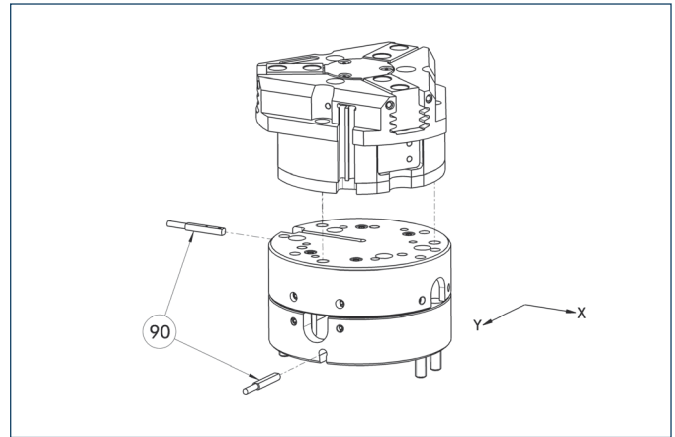

90 Monitoring

Grippers can be directly mounted without using an adapter plate. For details see our catalog "Robot Accessories".

Description	ID	Compensation travel	Reset force
<b>Compensation unit</b>			
AGE-F-XY-063-1	0324940	±4 mm	9 N
AGE-F-XY-063-2	0324941	±4 mm	10 N
AGE-F-XY-063-3	0324942	±4 mm	19.3 N

## Programmable magnetic switch

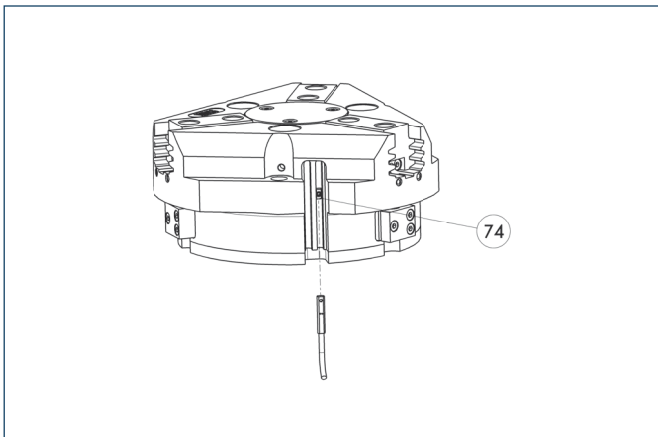

74 Stop for MMS-P

Position monitoring with two programmable positions per sensor. The end position monitoring is mounted in the C-slot.

Description	ID	Recommended product
<b>Programmable magnetic switch</b>		
MMS-P 22-S-M8-PNP	0301370	•
MMSK-P 22-S-PNP	0301371	
<b>Connection cables</b>		
KA BG08-L 4P-0500	0307767	
KA BG08-L 4P-1000	0307768	
KA BW08-L 4P-0500	0307765	
KA BW08-L 4P-1000	0307766	
<b>Sensor Distributor</b>		
V2-M8-4P-2XM8-3P	0301380	

① Please note the minimum permitted bending radii for the sensor cables, which are generally 35 mm.

① Per gripper one sensor (closer/NO) is required, optionally a cable extension.



## Electronic magnetic switches

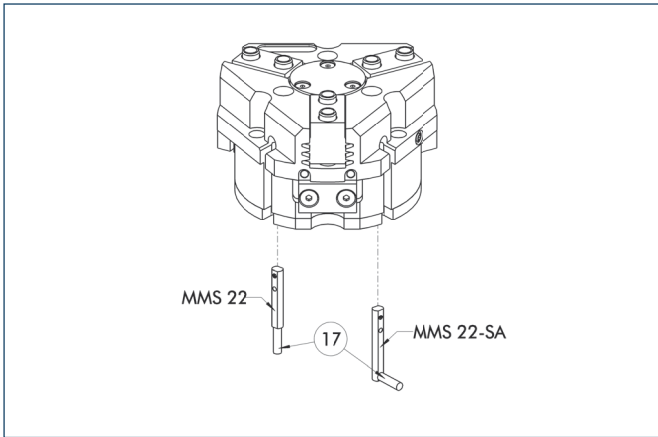

17 Cable outlet

End position monitoring for mounting in the C-slot

Description	ID	Recommended product
<b>Electronic magnetic switches</b>		
MMS 22-S-M5-PNP	0301438	
MMS 22-S-M5-NPN	0301439	
MMS 22-S-M8-PNP	0301432	•
MMS 22-S-M8-NPN	0301433	
MMSK 22-S-PNP	0301434	
MMSK 22-S-NPN	0301435	
<b>Electronic magnetic switches with lateral cable outlet</b>		
MMS 22-S-M5-PNP-SA	0301448	
MMS 22-S-M5-NPN-SA	0301449	
MMS 22-S-M8-PNP-SA	0301442	•
MMS 22-S-M8-NPN-SA	0301443	
MMSK 22-S-PNP-SA	0301444	
MMSK 22-S-NPN-SA	0301445	
<b>Connection cables</b>		
KA BG05-L 3P-0300	0301652	
KA BG08-L 3P-0300-PNP	0301622	
KA BG08-L 3P-0500-PNP	0301623	
KA BW05-L 3P-0300	0301650	
KA BW08-L 3P-0300-NPN	0301602	
KA BW08-L 3P-0300-PNP	0301594	
KA BW08-L 3P-0500-NPN	9641116	
KA BW08-L 3P-0500-PNP	0301502	
<b>Cable extensions</b>		
KV BW08-SG08 3P-0030-PNP	0301495	
KV BW08-SG08 3P-0100-PNP	0301496	
KV BW08-SG08 3P-0200-PNP	0301497	

① Two sensors (closer/NO) are required for each gripper, plus extension cables as an option.

① Please note the minimum permitted bending radii for the sensor cables, which are generally 35 mm.

## Inductive proximity switches

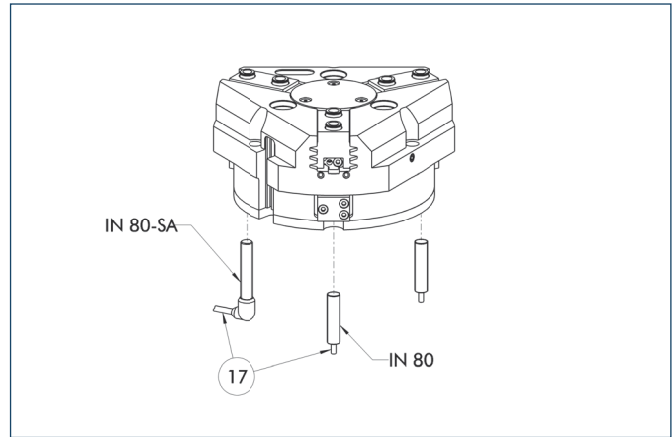

17 Cable outlet

End position monitoring for direct mounting

Description	ID	Recommended product
<b>Inductive proximity switches</b>		
IN 80-S-M8	0301478	•
IN 80-S-M12	0301578	
INK 80-S	0301550	
IN-C 80-S-M8	0301475	
<b>Inductive proximity switch with lateral outlet</b>		
IN 80-S-M12-SA	0301587	
IN 80-S-M8-SA	0301483	•
INK 80-S-SA	0301566	
<b>Connection cables</b>		
KA BG08-L 3P-0300-PNP	0301622	
KA BG08-L 3P-0500-PNP	0301623	
KA BG12-L 3P-0500-PNP	30016369	
KA BW08-L 3P-0300-PNP	0301594	
KA BW08-L 3P-0500-PNP	0301502	
KA BW12-L 3P-0300-PNP	0301503	
KA BW12-L 3P-0500-PNP	0301507	
<b>Cable extensions</b>		
KV BG12-SG12 3P-0030-PNP	0301999	
KV BG12-SG12 3P-0060-PNP	0301998	
KV BW08-SG08 3P-0030-PNP	0301495	
KV BW08-SG08 3P-0100-PNP	0301496	
KV BW08-SG08 3P-0200-PNP	0301497	
KV BW12-SG12 3P-0030-PNP	0301595	
KV BW12-SG12 3P-0100-PNP	0301596	
KV BW12-SG12 3P-0200-PNP	0301597	

① Two sensors (closer/NO) are required for each gripper, plus extension cables as an option.

① Please note the minimum permitted bending radii for the sensor cables, which are generally 35 mm.

You can find more detailed information and individual parts of the above-mentioned accessories in the "Accessories" catalog section.

## Cylindrical Reed Switches

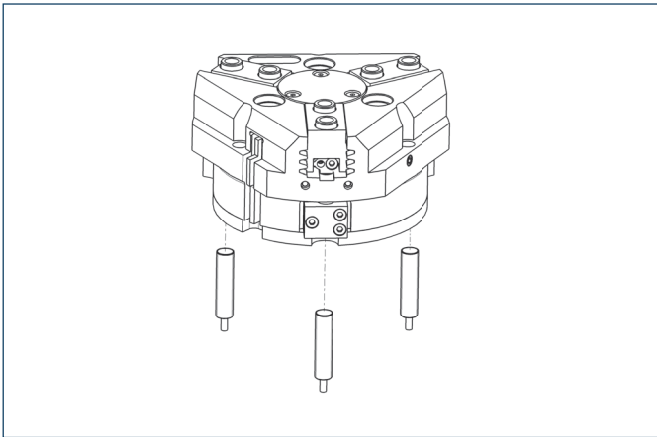

End position monitoring mounted with mounting kit

Description	ID
Mounting kit for proximity switch	
AS-RMS 80 PGN/PZN-plus 64/80	0377725
Reed Switches	
RMS 80-S-M8	0377721

- ① Two sensors (closer/NO) are required for each gripper, plus extension cables as an option.
- ① This mounting kit needs to be ordered optionally as an accessory.
- ① Please note the minimum permitted bending radii for the sensor cables, which are generally 35 mm.

## Analog position sensor

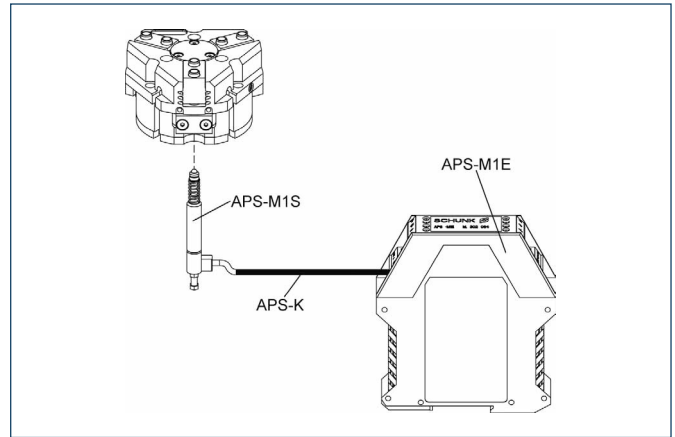

Analog multi position monitoring for any desired positions

Description	ID
Mounting kit	
AS-APS-M1-64/1	0302075
AS-APS-M1-64/2	0302076
Connection cables	
APS-K0200	0302066
APS-K0700	0302068
Electronic Processor	
APS-M1E	0302064
Sensor	
APS-M1S	0302062

- ① When using an APS system, for each gripper a mounting kit (AS-APS), an APS sensor (APS-M 1S, incl. 3 m cable) as well as an electronics (APS-M1e) are required.
- ① An extension cable (APS-K) can be connected between the sensor and the electronics as an option. The max. cable length between the sensor and the electronics is 10 m, between the electronics and their control unit (PLC) it is max. 1 m.



You can find more detailed information and individual parts of the above-mentioned accessories in the "Accessories" catalog section.

## Flexible Position Sensor

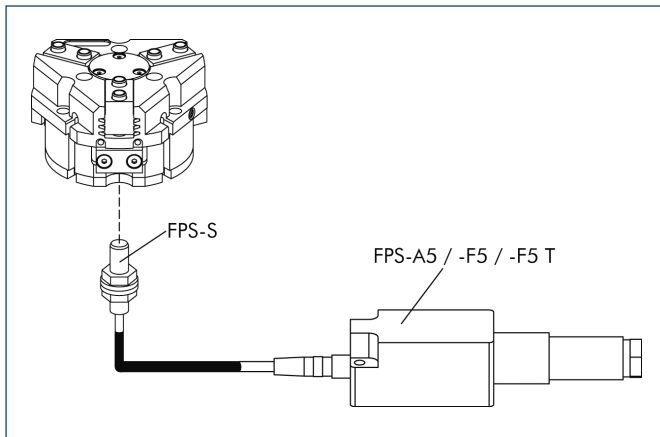

Flexible position monitoring of up to five positions

Description	ID
Mounting kit for FPS	
AS-PGN/PZN-plus 64/1, PGN/PZN-plus 80/2	0301630
Electronic Processor	
FPS-F5	0301805
FPS-F5 T	0301807
Sensor	
FPS-S M8	0301704

① When using a FPS system, a FPS sensor (FPS-S) and a control unit (FPS-F5 / F5 T or A5) are required for each gripper as well as a mounting kit (AS), if listed. Cable extensions (KV) are available as options in the "Accessories" catalog section.

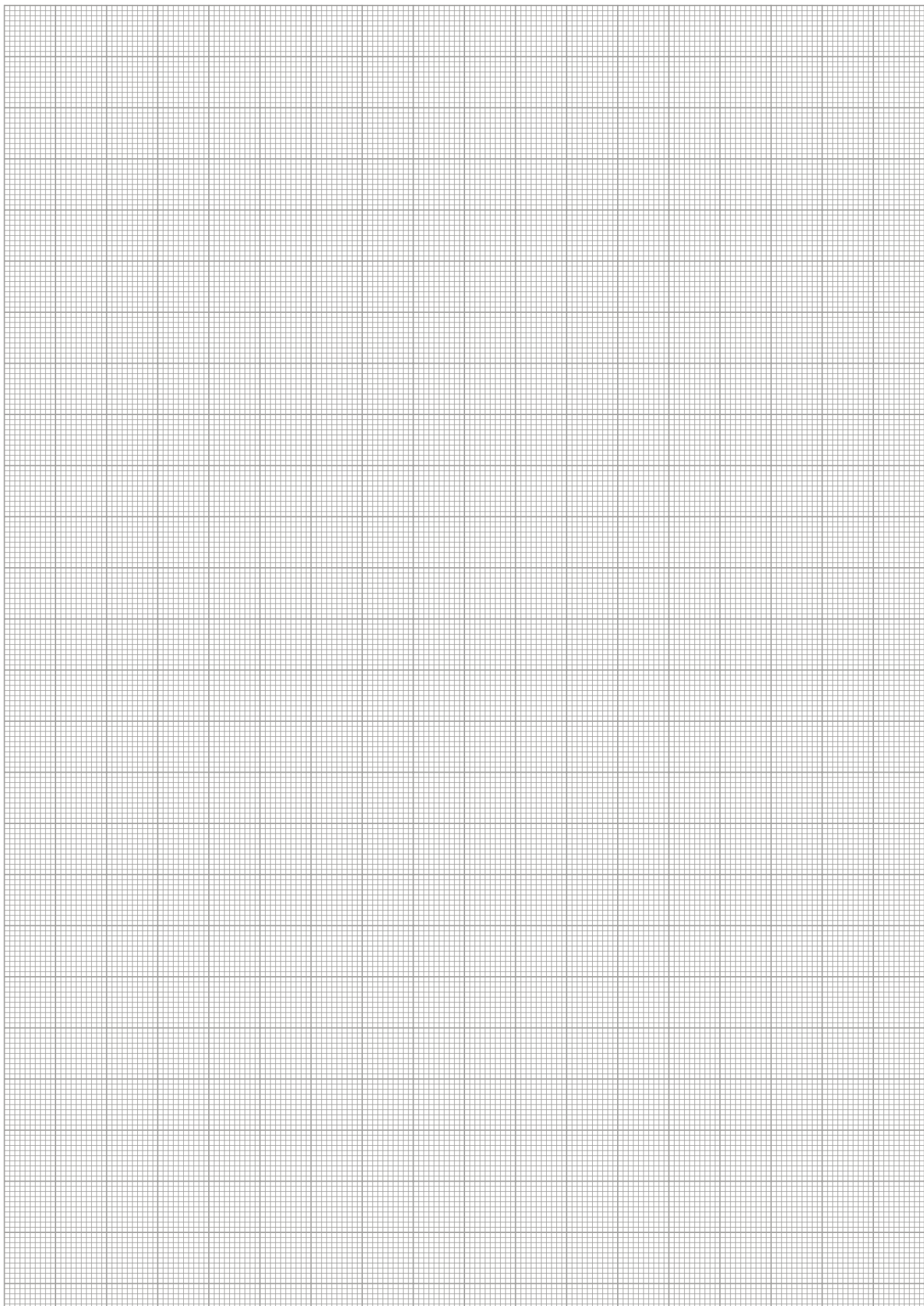

# PZN-plus 80

Pneumatic • 3-Finger Centric Gripper • Universal Gripper



## Gripping force, I.D. gripping

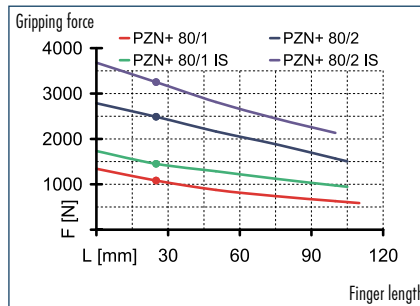

## Gripping force, O.D. gripping

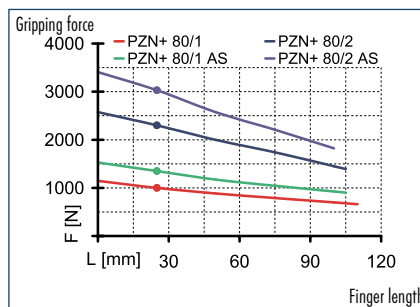

## Finger load

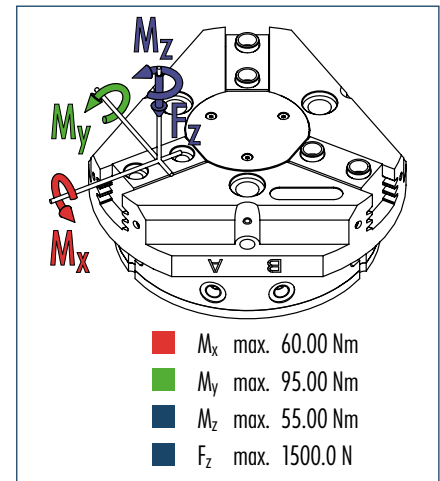

① The indicated moments and forces are static values, apply per base jaw and may occur simultaneously.  $M_y$  may arise in addition to the moment generated by the gripping force itself. If the max. permitted finger weight is exceeded, it is imperative to throttle the air pressure so that the jaw movement occurs without any hitting or bouncing. Service life may be reduced.

## Technical data

Description	PZN-plus 80-1	PZN-plus 80-2	PZN-plus 80-1-AS	PZN-plus 80-2-AS	PZN-plus 80-1-IS	PZN-plus 80-2-IS
ID	0303311	0303411	0303511	0303611	0303541	0303641
Stroke per finger [mm]	8	4	8	4	8	4
Closing force [N]	1000	2300	1350	3030		
Opening force [N]	1080	2490			1450	3250
Min. spring force [N]			350	730	370	760
Weight [kg]	0.79	0.79	0.96	0.96	0.96	0.96
Recommended workpiece weight [kg]	5	11.5	5	11.5	5	11.5
Air consumption per double stroke [cm <sup>3</sup> ]	60	60	108	108	108	108
Min./max. operating pressure [bar]	2/8	2/8	4/6.5	4/6.5	4/6.5	4/6.5
Nominal operating pressure [bar]	6	6	6	6	6	6
Closing/opening time [s]	0.05/0.05	0.05/0.05	0.03/0.05	0.03/0.05	0.06/0.04	0.06/0.04
Max. permitted finger length [mm]	110	105	105	100	105	100
Max. permitted weight per finger [kg]	0.6	0.6	0.6	0.6	0.6	0.6
IP class	40	40	40	40	40	40
Min./max. ambient temperature [°C]	-10/90	-10/90	-10/90	-10/90	-10/90	-10/90
Repeat accuracy [mm]	0.01	0.01	0.01	0.01	0.01	0.01
Cleanroom class						
ISO-classification 14644-1	5	5	5	5	5	5

## OPTIONS and their characteristics

Dust-protection version	37303311	37303411	37303511	37303611	37303541	37303641
IP class	64	64	64	64	64	64
Weight [kg]	1	1	1.17	1.17	1.17	1.17
Anti-corrosion version	38303311	38303411	38303511	38303611	38303541	38303641
High-temperature version	39303311	39303411	39303511	39303611	39303541	39303641
Min./max. ambient temperature [°C]	-10/130	-10/130	-10/130	-10/130	-10/130	-10/130
Force intensified version	PZN-plus 80-1-KVZ	PZN-plus 80-2-KVZ	PZN-plus 80-1-AS-KVZ		PZN-plus 80-1-IS-KVZ	
ID	0372202	0372212	0372222		0372242	
Closing force [N]	1000	4140	2150			
Opening force [N]	1945	4480			2315	
Weight [kg]	1.2	1.2	1.4		1.4	
Maximum pressure [bar]	8	8	6		6	
Max. permitted finger length [mm]	100	80	80		80	
Precision version	0303341	0303441	0303491	0303591		









### Force measuring jaws

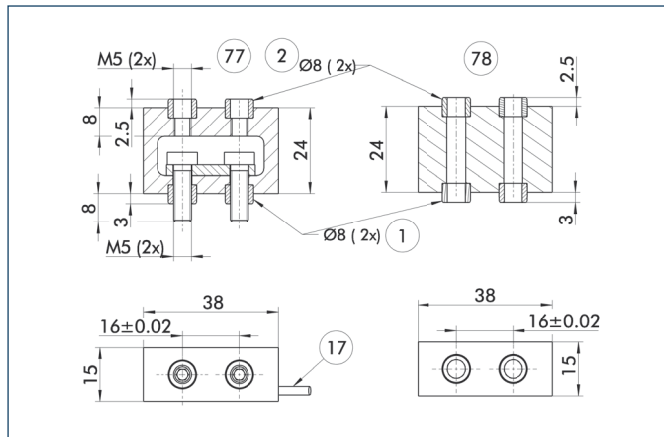

- ① Gripper connection
- ② Finger connection
- ⑦ Active intermediate jaws
- ⑧ Passive intermediate jaws
- ⑰ Cable outlet

Force measuring jaws measure gripping forces, but can also determine workpiece weights or dimensional deviations. There are active and passive intermediate jaws (FMS-ZBA or FMS-ZBP). At least one active force measuring jaw is required per gripper, the rest can be passive. For each active jaw, a FMS-A1 control unit and a FMS-A connection cable are required.

Description	ID
<b>Active intermediate jaws</b>	
FMS-ZBA 80	0301834
<b>Passive intermediate jaws</b>	
FMS-ZBP 80	0301835
<b>Electronic Processor</b>	
FMS-A1	0301810
<b>Connection cables</b>	
FMS-AK0200	0301820
FMS-AK0500	0301821
FMS-AK1000	0301822
FMS-AK2000	0301823

### Finger blanks

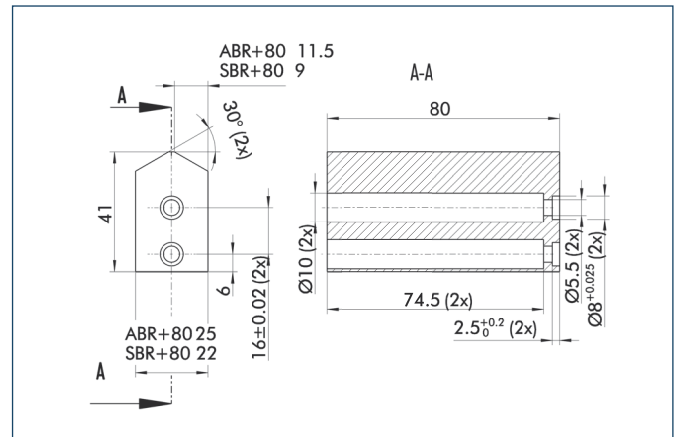

Finger blanks for customized subsequent machining

Description	ID	Material	Scope of delivery
<b>Finger blanks</b>			
ABR-plus 80	0300011	Aluminum	1
SBR-plus 80	0300021	16 MnCr 5	1

## Tolerance compensation unit

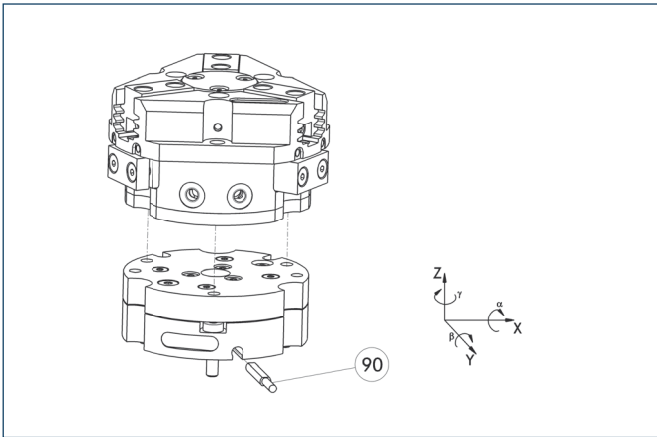

90 Monitoring of locking

Grippers can be directly mounted without an adapter plate. Tolerance compensation unit and gripper have an identical screw connection diagram. Therefore the tolerance compensation units can be assembled later. Please consider the additional assembly height of the tolerance compensation unit. For details see catalog "Robot Accessories".

Description	ID	Locking	Deflection
<b>Compensation unit</b>			
TCU-080-3-MV-Z	0324784	Yes	
TCU-080-3-OV-Z	0324785	No	

## Compensation unit with spring reset

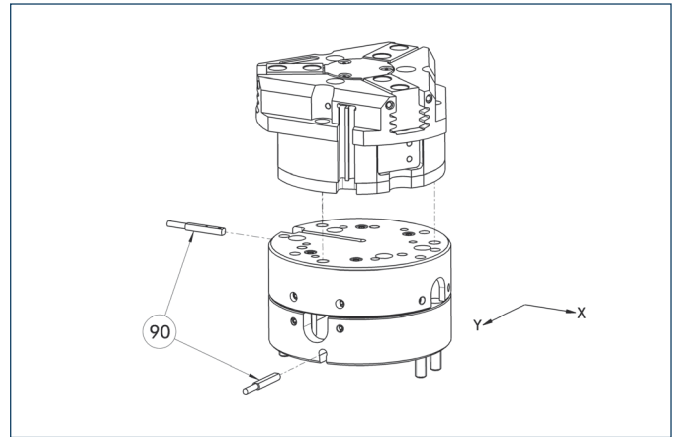

90 Monitoring

Grippers can be directly mounted without using an adapter plate. For details see our catalog "Robot Accessories".

Description	ID	Compensation travel	Reset force
<b>Compensation unit</b>			
AGE-F-XY-063-1	0324940	±4 mm	9 N
AGE-F-XY-063-2	0324941	±4 mm	10 N
AGE-F-XY-063-3	0324942	±4 mm	19.3 N

## Programmable magnetic switch

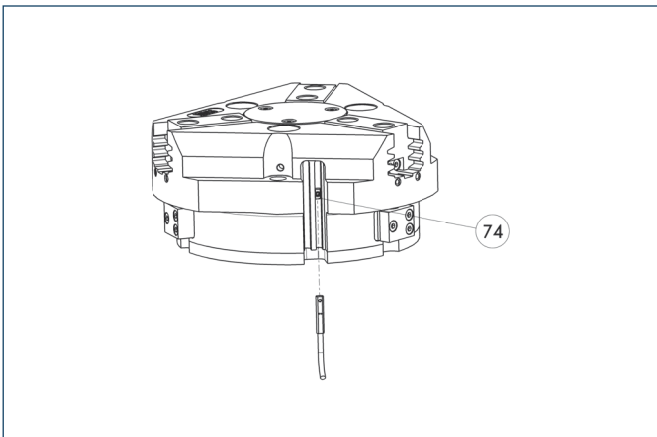

74 Stop for MMS-P

Position monitoring with two programmable positions per sensor. The end position monitoring is mounted in the C-slot.

Description	ID	Recommended product
<b>Programmable magnetic switch</b>		
MMS-P 22-S-M8-PNP	0301370	•
MMSK-P 22-S-PNP	0301371	
<b>Connection cables</b>		
KA BG08-L 4P-0500	0307767	
KA BG08-L 4P-1000	0307768	
KA BW08-L 4P-0500	0307765	
KA BW08-L 4P-1000	0307766	
<b>Sensor Distributor</b>		
V2-M8-4P-2XM8-3P	0301380	

① Please note the minimum permitted bending radii for the sensor cables, which are generally 35 mm.

① Per gripper one sensor (closer/NO) is required, optionally a cable extension.

## Electronic magnetic switches

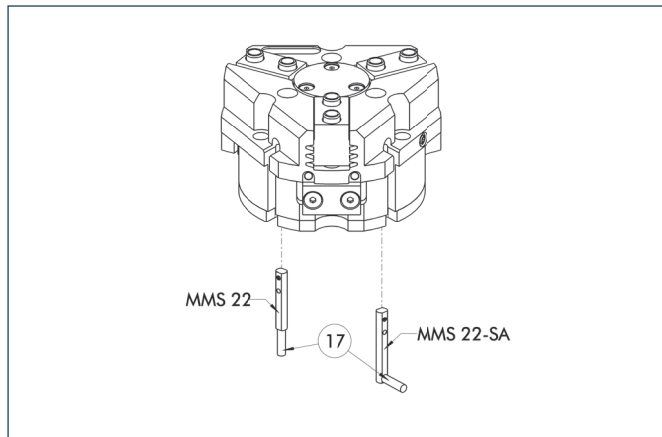

⑰ Cable outlet

End position monitoring for mounting in the C-slot

Description	ID	Recommended product
<b>Electronic magnetic switches</b>		
MMS 22-S-M5-PNP	0301438	
MMS 22-S-M5-NPN	0301439	
MMS 22-S-M8-PNP	0301432	•
MMS 22-S-M8-NPN	0301433	
MMSK 22-S-PNP	0301434	
MMSK 22-S-NPN	0301435	
<b>Electronic magnetic switches with lateral cable outlet</b>		
MMS 22-S-M5-PNP-SA	0301448	
MMS 22-S-M5-NPN-SA	0301449	
MMS 22-S-M8-PNP-SA	0301442	•
MMS 22-S-M8-NPN-SA	0301443	
MMSK 22-S-PNP-SA	0301444	
MMSK 22-S-NPN-SA	0301445	
<b>Reed Switches</b>		
RMS 22-S-M8	0377720	•
<b>Connection cables</b>		
KA BG05-L 3P-0300	0301652	
KA BG08-L 3P-0300-PNP	0301622	
KA BG08-L 3P-0500-PNP	0301623	
KA BW05-L 3P-0300	0301650	
KA BW08-L 3P-0300-NPN	0301602	
KA BW08-L 3P-0300-PNP	0301594	
KA BW08-L 3P-0500-NPN	9641116	
KA BW08-L 3P-0500-PNP	0301502	
<b>Cable extensions</b>		
KV BW08-SG08 3P-0030-PNP	0301495	
KV BW08-SG08 3P-0100-PNP	0301496	
KV BW08-SG08 3P-0200-PNP	0301497	

① Two sensors (closer/NO) are required for each gripper, plus extension cables as an option.

① Please note the minimum permitted bending radii for the sensor cables, which are generally 35 mm.

## Inductive proximity switches

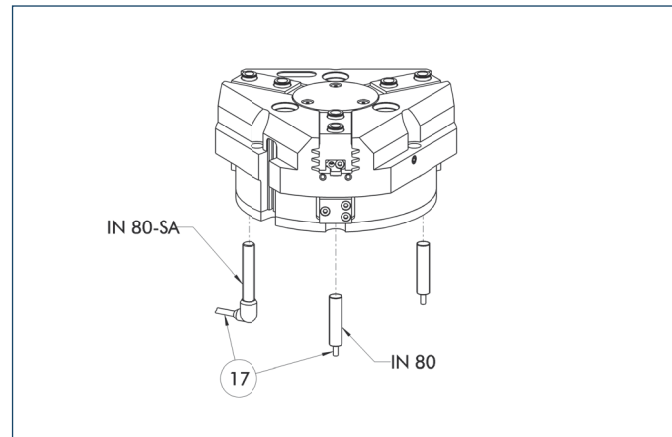

⑰ Cable outlet

End position monitoring for direct mounting

Description	ID	Recommended product
<b>Inductive proximity switches</b>		
IN 80-S-M8	0301478	•
IN 80-S-M12	0301578	
INK 80-S	0301550	
IN-C 80-S-M8	0301475	
<b>Inductive proximity switch with lateral outlet</b>		
IN 80-S-M12-SA	0301587	
IN 80-S-M8-SA	0301483	•
INK 80-S-SA	0301566	
<b>Connection cables</b>		
KA BG08-L 3P-0300-PNP	0301622	
KA BG08-L 3P-0500-PNP	0301623	
KA BG12-L 3P-0500-PNP	30016369	
KA BW08-L 3P-0300-PNP	0301594	
KA BW08-L 3P-0500-PNP	0301502	
KA BW12-L 3P-0300-PNP	0301503	
KA BW12-L 3P-0500-PNP	0301507	
<b>Cable extensions</b>		
KV BG12-SG12 3P-0030-PNP	0301999	
KV BG12-SG12 3P-0060-PNP	0301998	
KV BW08-SG08 3P-0030-PNP	0301495	
KV BW08-SG08 3P-0100-PNP	0301496	
KV BW08-SG08 3P-0200-PNP	0301497	
KV BW12-SG12 3P-0030-PNP	0301595	
KV BW12-SG12 3P-0100-PNP	0301596	
KV BW12-SG12 3P-0200-PNP	0301597	

① Two sensors (closer/NO) are required for each gripper, plus extension cables as an option.

① Please note the minimum permitted bending radii for the sensor cables, which are generally 35 mm.

## Cylindrical Reed Switches

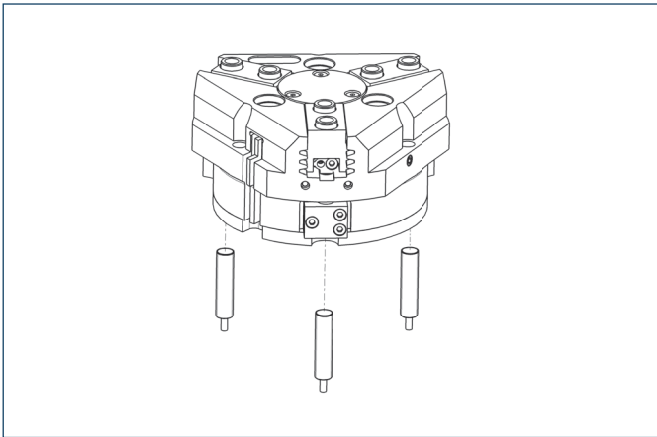

End position monitoring mounted with mounting kit

Description	ID
Mounting kit for proximity switch	
AS-RMS 80 PGN/PZN-plus 64/80	0377725
Reed Switches	
RMS 80-S-M8	0377721

- ① Two sensors (closer/NO) are required for each gripper, plus extension cables as an option.
- ① This mounting kit needs to be ordered optionally as an accessory.
- ① Please note the minimum permitted bending radii for the sensor cables, which are generally 35 mm.

## Analog position sensor

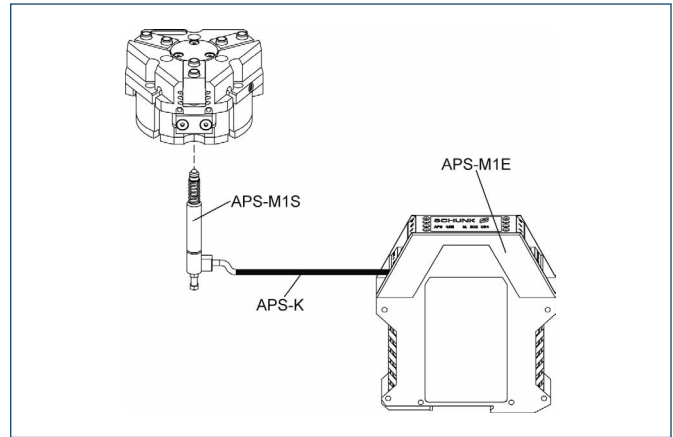

Analog multi position monitoring for any desired positions

Description	ID
Mounting kit	
AS-APS-M1-80/1	0302077
AS-APS-M1-80/2	0302078
Connection cables	
APS-K0200	0302066
APS-K0700	0302068
Electronic Processor	
APS-M1E	0302064
Sensor	
APS-M1S	0302062

- ① When using an APS system, for each gripper a mounting kit (AS-APS), an APS sensor (APS-M1S, incl. 3 m cable) as well as an electronics (APS-M1e) are required.
- ① An extension cable (APS-K) can be connected between the sensor and the electronics as an option. The max. cable length between the sensor and the electronics is 10 m, between the electronics and their control unit (PLC) it is max. 1 m.

## Flexible Position Sensor

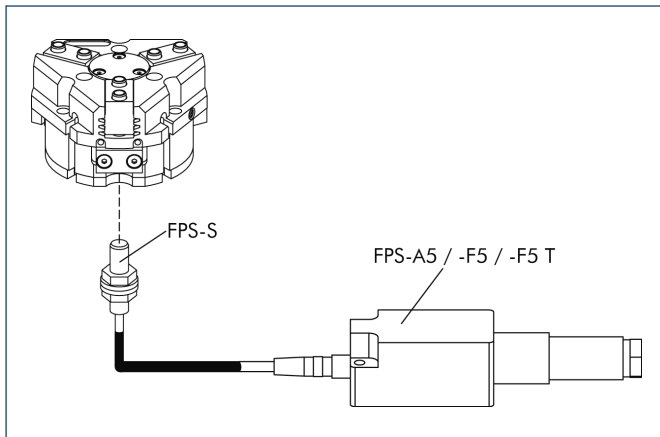

Flexible position monitoring of up to five positions

Description	ID
Mounting kit for FPS	
AS-PGN/PZN-plus 64/1, PGN/PZN-plus 80/2	0301630
AS-PGN-plus/PZN-plus 80/1, PZB 80/100	0301632
Electronic Processor	
FPS-F5	0301805
FPS-F5 T	0301807
Sensor	
FPS-S M8	0301704

① When using a FPS system, a FPS sensor (FPS-S) and a control unit (FPS-F5 / F5 T or A5) are required for each gripper as well as a mounting kit (AS), if listed. Cable extensions (KV) are available as options in the "Accessories" catalog section.

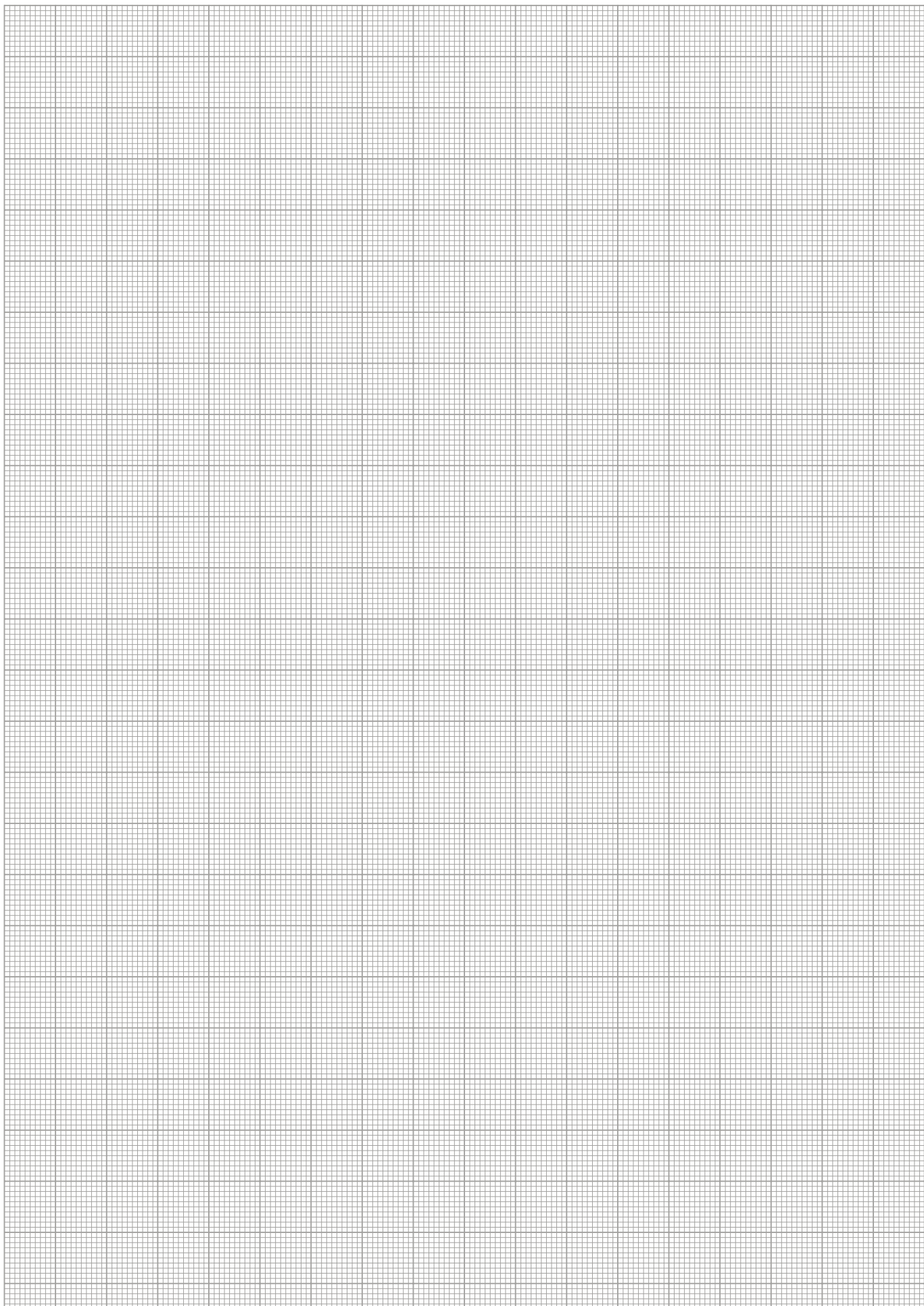

# PZN-plus 100

Pneumatic • 3-Finger Centric Gripper • Universal Gripper



## Gripping force, I.D. gripping

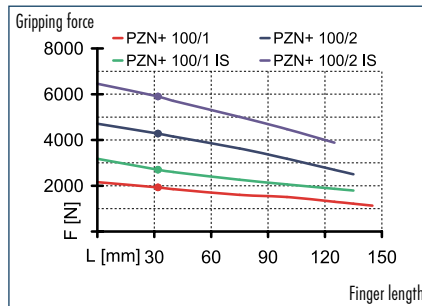

## Gripping force, O.D. gripping

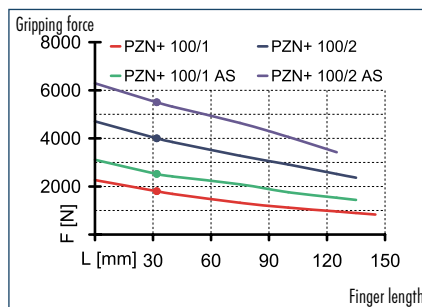

## Finger load

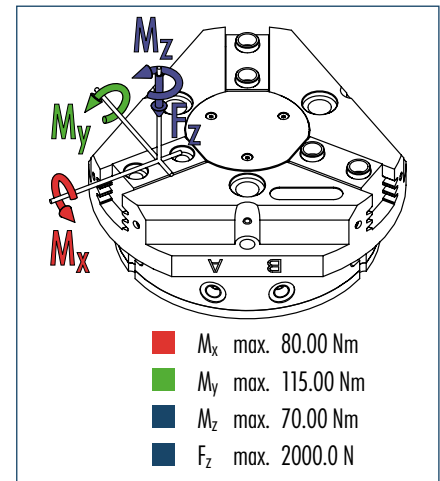

① The indicated moments and forces are static values, apply per base jaw and may occur simultaneously.  $M_y$  may arise in addition to the moment generated by the gripping force itself. If the max. permitted finger weight is exceeded, it is imperative to throttle the air pressure so that the jaw movement occurs without any hitting or bouncing. Service life may be reduced.

## Technical data

Description	PZN-plus 100-1	PZN-plus 100-2	PZN-plus 100-1-AS	PZN-plus 100-2-AS	PZN-plus 100-1-IS	PZN-plus 100-2-IS
ID	0303312	0303412	0303512	0303612	0303542	0303642
Stroke per finger [mm]	10	5	10	5	10	5
Closing force [N]	1800	4000	2520	5500		
Opening force [N]	1920	4280			2700	5900
Min. spring force [N]			720	1500	780	1620
Weight [kg]	1.41	1.41	1.95	1.95	1.95	1.95
Recommended workpiece weight [kg]	9	20	9	20	9	20
Air consumption per double stroke [cm <sup>3</sup> ]	120	120	210	210	210	210
Min./max. operating pressure [bar]	2/8	2/8	4/6.5	4/6.5	4/6.5	4/6.5
Nominal operating pressure [bar]	6	6	6	6	6	6
Closing/opening time [s]	0.1/0.1	0.1/0.1	0.1/0.2	0.1/0.2	0.2/0.1	0.2/0.1
Max. permitted finger length [mm]	145	135	135	125	135	125
Max. permitted weight per finger [kg]	1.1	1.1	1.1	1.1	1.1	1.1
IP class	40	40	40	40	40	40
Min./max. ambient temperature [°C]	-10/90	-10/90	-10/90	-10/90	-10/90	-10/90
Repeat accuracy [mm]	0.01	0.01	0.01	0.01	0.01	0.01
Cleanroom class						
ISO-classification 14644-1	5	5	5	5	5	5

## OPTIONS and their characteristics

Dust-protection version	37303312	37303412	37303512	37303612	37303542	37303642
IP class	64	64	64	64	64	64
Weight [kg]	1.9	1.9	2.44	2.44	2.44	2.44
Anti-corrosion version	38303312	38303412	38303512	38303612	38303542	38303642
High-temperature version	39303312	39303412	39303512	39303612	39303542	39303642
Min./max. ambient temperature [°C]	-10/130	-10/130	-10/130	-10/130	-10/130	-10/130
Force intensified version	PZN-plus 100-1-KVZ	PZN-plus 100-2-KVZ	PZN-plus 100-1-AS-KVZ		PZN-plus 100-1-IS-KVZ	
ID	0372203	0372213	0372223		0372243	
Closing force [N]	3240	7200	3960			
Opening force [N]	3455	7705			4235	
Weight [kg]	2.3	2.3	2.7		2.7	
Maximum pressure [bar]	8	8	6		6	
Max. permitted finger length [mm]	100	80	80		80	
Precision version	0303342	0303442	0303492	0303592		

## Main view

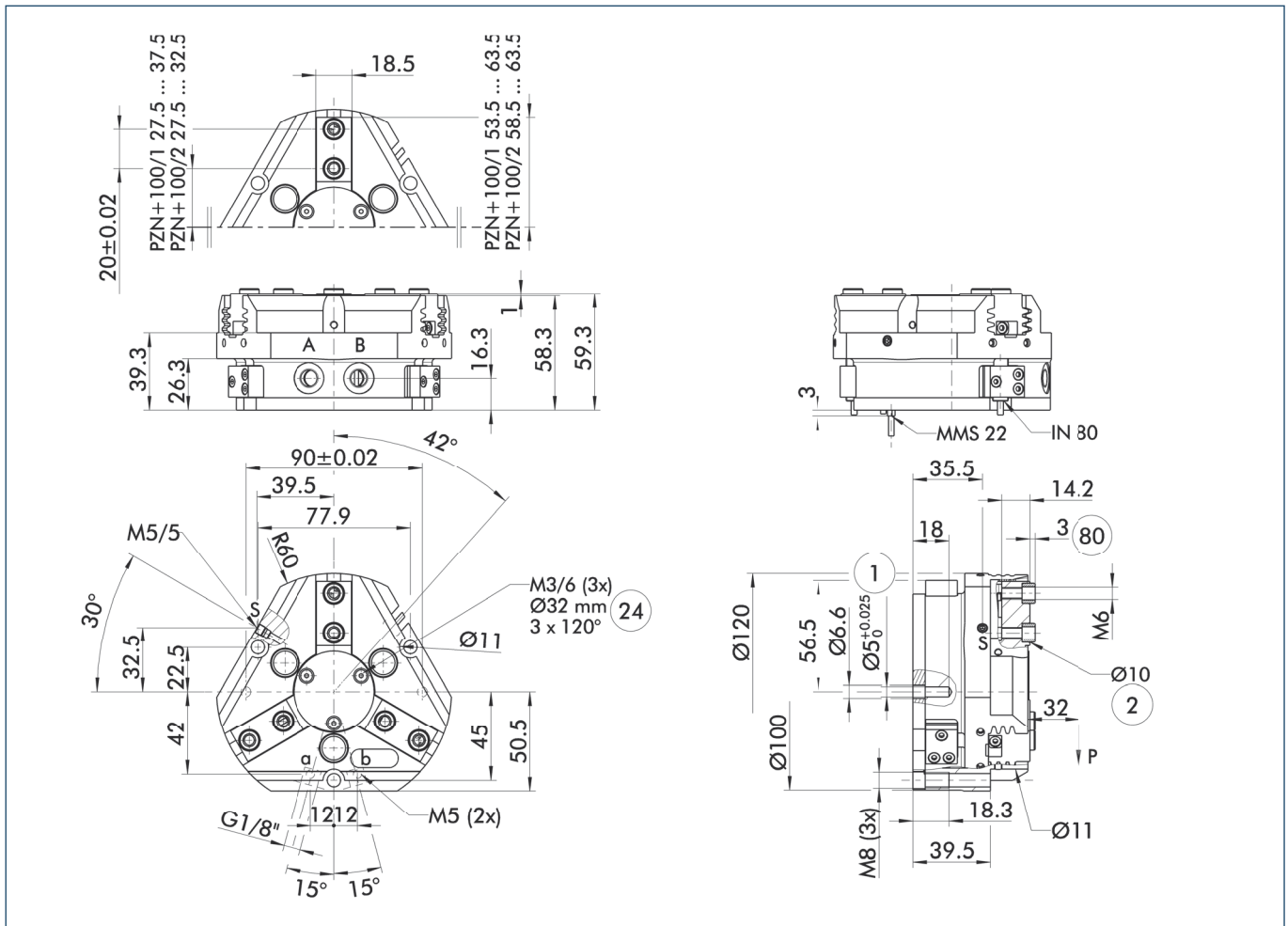

The drawing shows the gripper in the basic version with closed jaws, the dimensions do not include the options described below.

① The SDV-P pressure maintenance valve can also be used for I.D. or O.D. gripping alternatively or in addition to the spring-loaded, mechanical gripping force maintenance device (see "Accessories" catalog section).

A, a Main/direct connection, gripper opening  
B, b Main/direct connection, gripper closing

S Air purge connection  
① Gripper connection  
② Finger connection

②④ Bolt circle  
⑧⑩ Depth of the centering sleeve hole in the matching part

## Hose-free direct connection

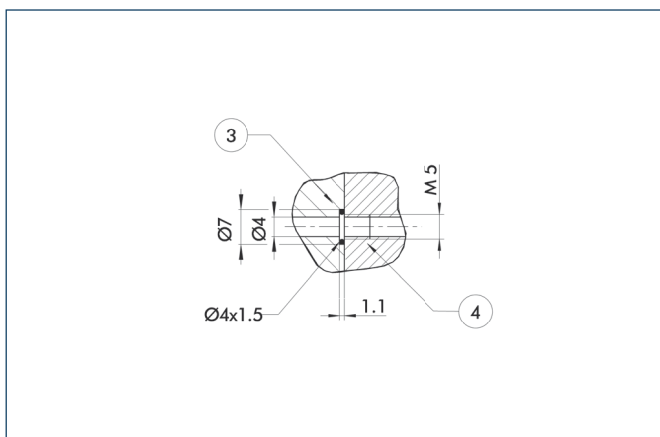

③ Adapter  
④ Gripper

The direct connection is used for supplying compressed air without hoses. Instead, the pressure medium is fed through bore-holes in the mounting plate.

## AS/IS gripping force maintenance device

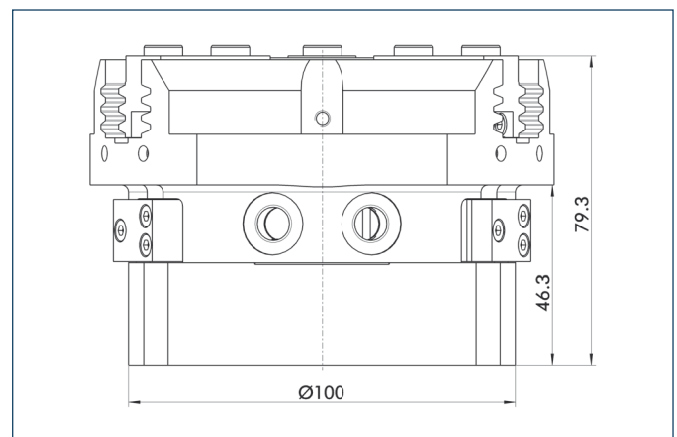

The mechanical gripping force maintenance device ensures a minimum gripping force even in case of pressure drop. This acts as closing force in the AS version, and as opening force in the IS version. In addition, the gripping force maintenance device can also be used for increasing the gripping force or for single-acting gripping.



# PZN-plus 100

Pneumatic • 3-Finger Centric Gripper • Universal Gripper

## Dust-protection version

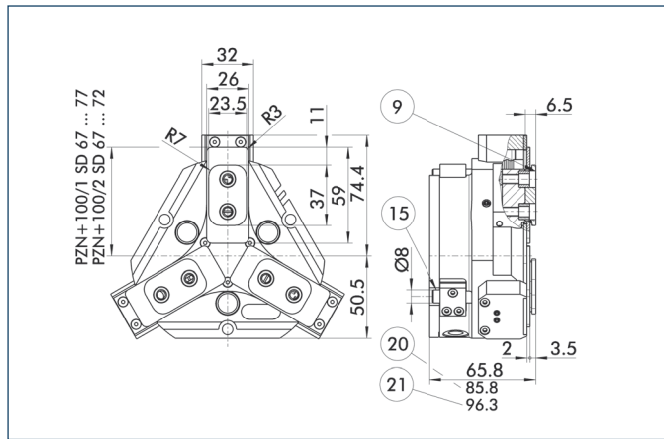

- ⑨ For mounting screw connection diagram, see basic version
- ⑮ Sealing bolt
- ⑳ For AS / IS version
- ㉑ Applies for KVZ version

The "dust-protection" option increases the degree of protection against penetrating substances. The screw connection diagram shifts by the height of the intermediate jaw. The finger length is still measured from the upper edge of the gripper housing.

## Force intensified version

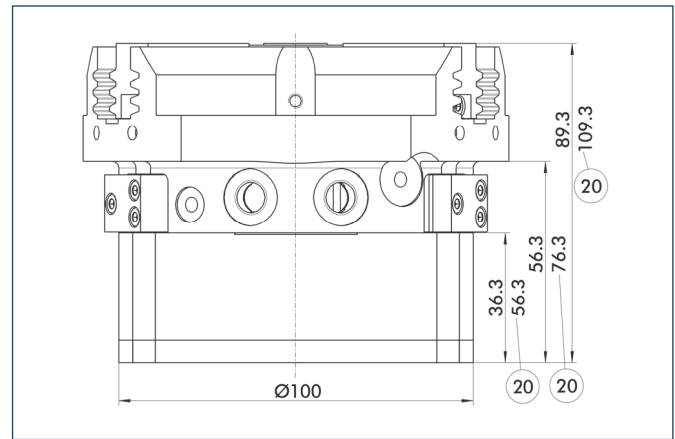

- ㉒ For AS / IS version

The KVZ cylinder increases the gripping forces during opening and closing. A second, in series-connected piston also increases the force on the wedge hook. The full gripping force shown in the data table is sometimes only reached after a few hundred gripping cycles. Please consider that grippers which are equipped with a gripping force maintenance device (AS / IS) are higher.

## Precision version

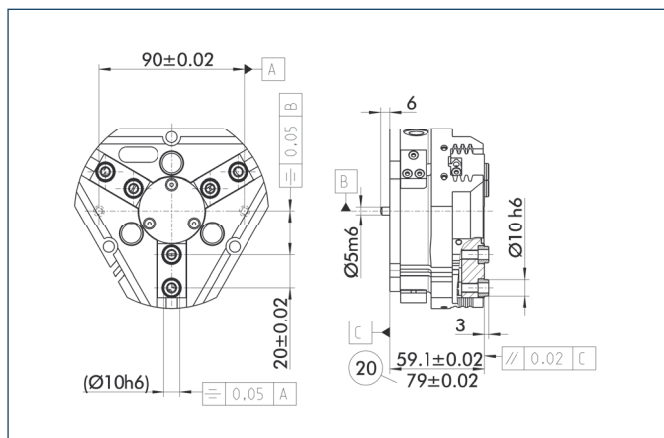

- ㉓ For AS / IS version

The indicated tolerances just refer to the types of precision versions shown in the chart of technical specifications. All other types of precision versions are available on request.

## Modular Assembly Automation

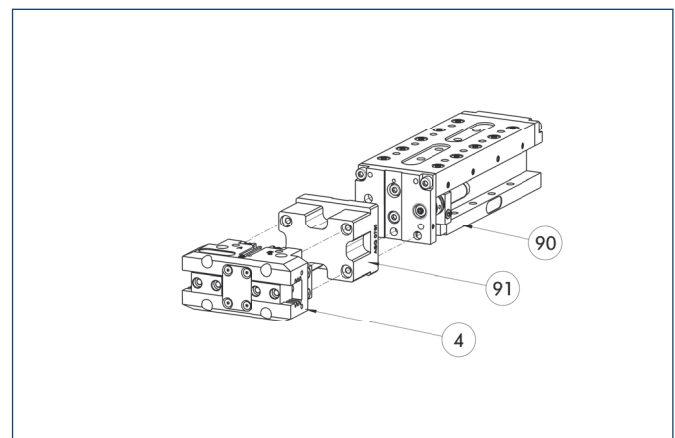

- ④ Gripper
- ⑨⑩ CLM
- ⑨① ASG

This gripper can be combined with the standard linear modules LM, KLM, CLM and ELM of the GEMOTEC modular system. For more information see our main catalog "Modular Assembly Automation".

### Spring-loaded pressure piece

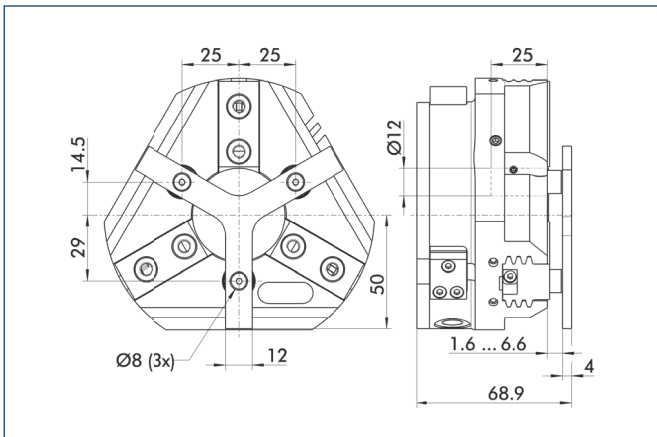

For spring-supported positioning of the workpiece against a stop after the gripper has opened. Especially developed for loading machines.

Description	ID	Stroke	Min. force
Spring-loaded pressure piece			
A-PZN-plus/DPZ-plus 100	0303722	5 mm	35 N

① The pressure piece cannot be combined with the dust-protection version. Please contact us if you require a special pressure piece.

### Quick-change Jaw System

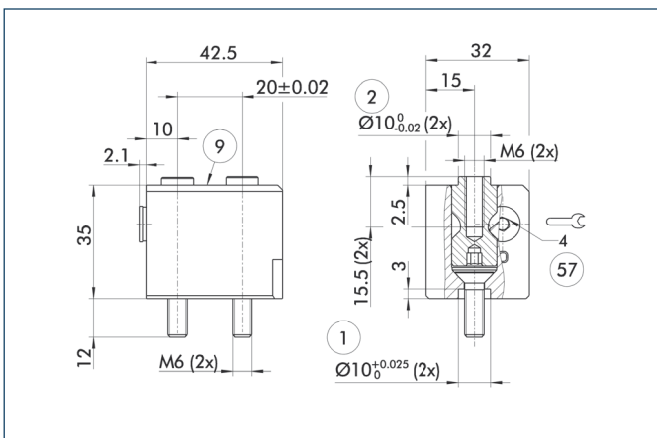

- ① Gripper connection
- ② Finger connection
- ③ For mounting screw connection diagram, see basic version
- ⑤7 Locking

The BSW quick-change jaw system enables top jaws to be changed on the gripper manually and rapidly. An adapter (BSWS-A) and a base (BSWS-B) are required for each gripper jaw.

For a reverse assembly without height set-up, one adapter (BSWS-A) and a kit (BSWS-U) per gripper jaw are required. Another effect of the BSWS-U, is that there are no disturbing fastening bores in the finger contour.

Description	ID
Quick-change Jaw System adapter	
BSWS-A 100	0303026
Quick-change Jaw System base	
BSWS-B 100	0303027
Quick-change Jaw System reversed	
BSWS-U 100	0303043

### Protection cover

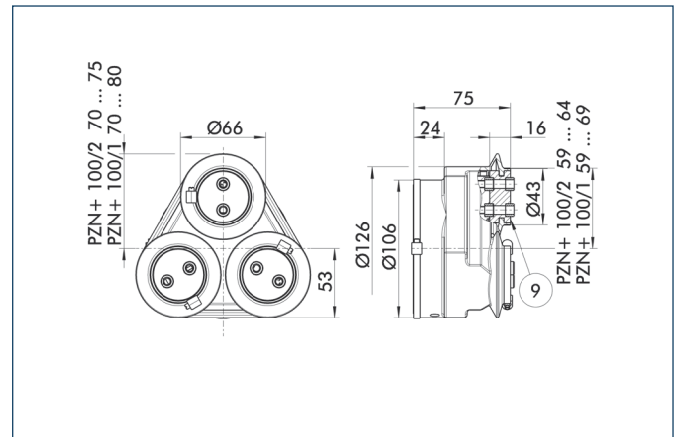

⑨ For mounting screw connection diagram, see basic version

The HUE protective cover completely protects the gripper against external influences up to IP65 if an additional sealing of the cover bottom is provided as part of the application. The mounting diagram shifts by the height of the intermediate jaw.

Description	ID	Cleanroom class ISO-classification 14644-1
Protection cover		
HUE PZN-plus 100	0303482	2

### Universal intermediate jaw

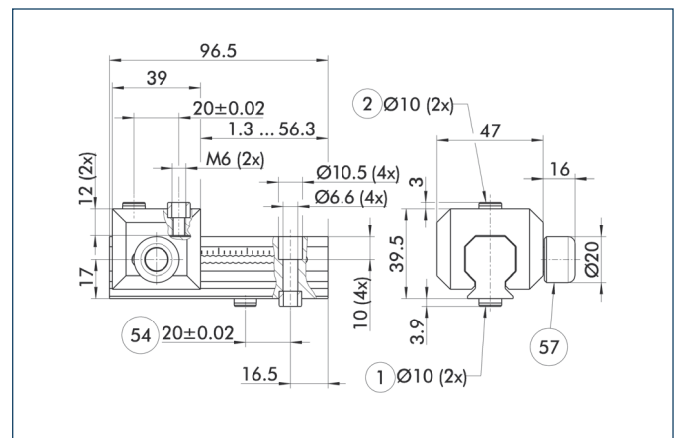

- ① Gripper connection
- ② Finger connection
- ⑤4 Optional right or left connection
- ⑤7 Locking

The universal intermediate jaw allows fast tool-free and reliable plugging and shifting of top jaws at the gripper.

Description	ID	Grid dimension
Universal intermediate jaw		
UZB 100	0300044	2.5 mm
UZB-S 100	5518272	2.5 mm

① The slide UZB-S can be removed completely and has to be ordered separately. Moreover, it allows a fast jaw change.



You can find more detailed information and individual parts of the above-mentioned accessories in the "Accessories" catalog section.

## Force measuring jaws

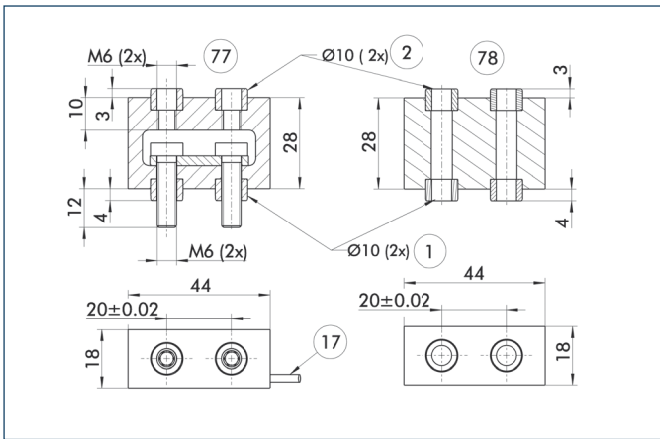

- ① Gripper connection
- ② Finger connection
- ⑦ Active intermediate jaws
- ⑧ Passive intermediate jaws
- ⑰ Cable outlet

Force measuring jaws measure gripping forces, but can also determine workpiece weights or dimensional deviations. There are active and passive intermediate jaws (FMS-ZBA or FMS-ZBP). At least one active force measuring jaw is required per gripper, the rest can be passive. For each active jaw, a FMS-A1 control unit and a FMS-A connection cable are required.

Description	ID
<b>Active intermediate jaws</b>	
FMS-ZBA 100	0301836
<b>Passive intermediate jaws</b>	
FMS-ZBP 100	0301837
<b>Electronic Processor</b>	
FMS-A1	0301810
<b>Connection cables</b>	
FMS-AK0200	0301820
FMS-AK0500	0301821
FMS-AK1000	0301822
FMS-AK2000	0301823

## Finger blanks

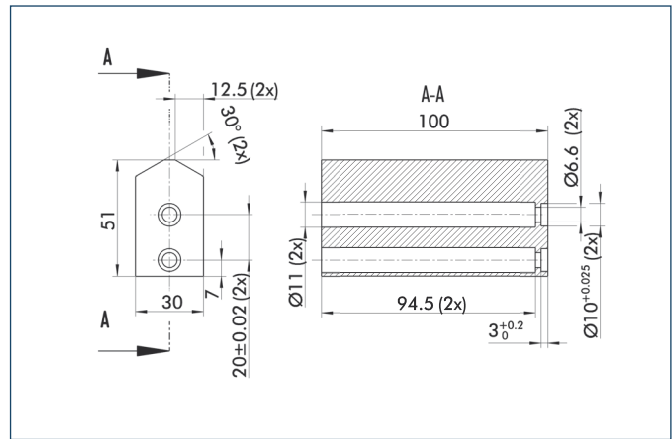

Finger blanks for customized subsequent machining

Description	ID	Material	Scope of delivery
<b>Finger blanks</b>			
ABR-plus 100	0300012	Aluminum	1
SBR-plus 100	0300022	16 MnCr 5	1

### Tolerance compensation unit

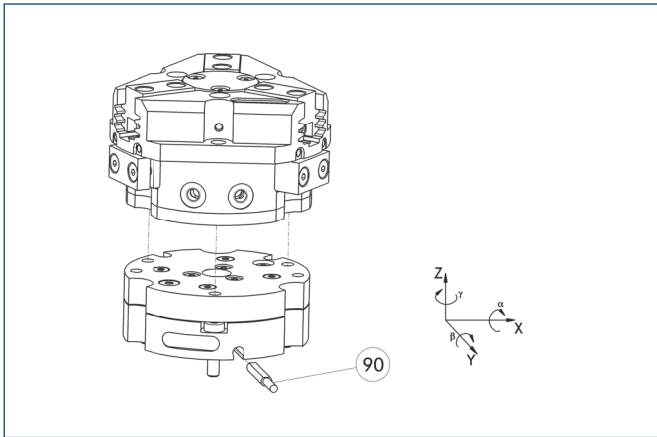

90 Monitoring of locking

Grippers can be directly mounted without an adapter plate. Tolerance compensation unit and gripper have an identical screw connection diagram. Therefore the tolerance compensation units can be assembled later. Please consider the additional assembly height of the tolerance compensation unit. For details see catalog "Robot Accessories".

Description	ID	Locking	Deflection
<b>Compensation unit</b>			
TCU-100-2-MV-Z	0324794	Yes	
TCU-100-2-OV-Z	0324799	No	

### Compensation unit with spring reset

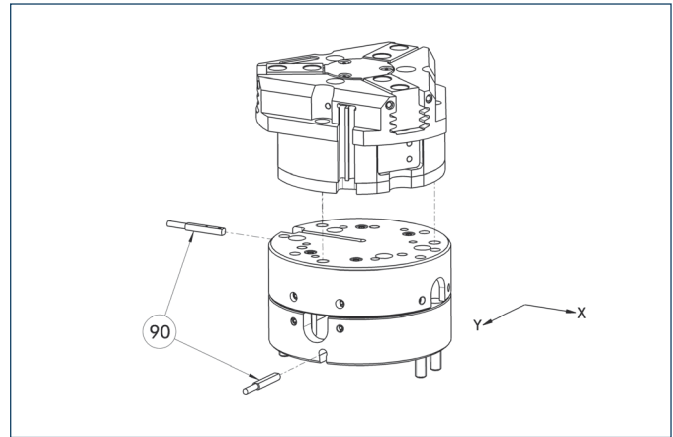

90 Monitoring

Grippers can be directly mounted without using an adapter plate. For details see our catalog "Robot Accessories".

Description	ID	Compensation travel	Reset force
<b>Compensation unit</b>			
AGE-F-XY-080-1	0324960	±5 mm	28.3 N
AGE-F-XY-080-2	0324961	±5 mm	42.5 N
AGE-F-XY-080-3	0324962	±5 mm	47.6 N

### Programmable magnetic switch

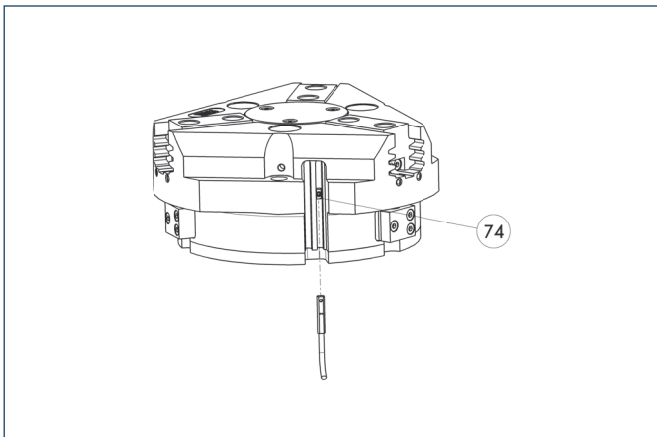

74 Stop for MMS-P

Position monitoring with two programmable positions per sensor. The end position monitoring is mounted in the C-slot.

Description	ID	Recommended product
<b>Programmable magnetic switch</b>		
MMS-P 22-S-M8-PNP	0301370	•
MMSK-P 22-S-PNP	0301371	
<b>Connection cables</b>		
KA BG08-L 4P-0500	0307767	
KA BG08-L 4P-1000	0307768	
KA BW08-L 4P-0500	0307765	
KA BW08-L 4P-1000	0307766	
<b>Sensor Distributor</b>		
V2-M8-4P-2XM8-3P	0301380	

① Please note the minimum permitted bending radii for the sensor cables, which are generally 35 mm.

① Per gripper one sensor (closer/NO) is required, optionally a cable extension.

## Electronic magnetic switches

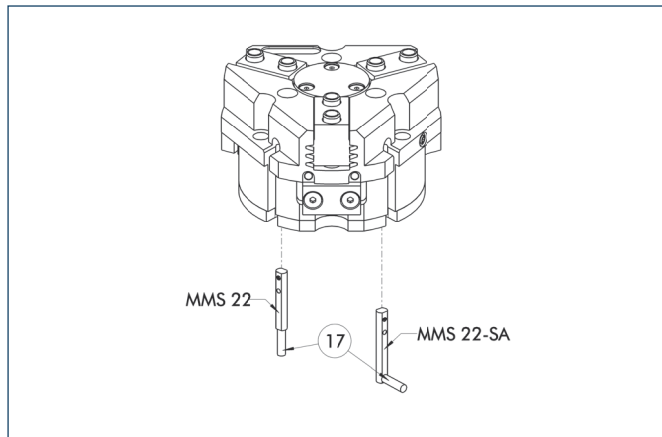

17 Cable outlet

End position monitoring for mounting in the C-slot

Description	ID	Recommended product
<b>Electronic magnetic switches</b>		
MMS 22-S-M5-PNP	0301438	
MMS 22-S-M5-NPN	0301439	
MMS 22-S-M8-PNP	0301432	•
MMS 22-S-M8-NPN	0301433	
MMSK 22-S-PNP	0301434	
MMSK 22-S-NPN	0301435	
<b>Electronic magnetic switches with lateral cable outlet</b>		
MMS 22-S-M5-PNP-SA	0301448	
MMS 22-S-M5-NPN-SA	0301449	
MMS 22-S-M8-PNP-SA	0301442	•
MMS 22-S-M8-NPN-SA	0301443	
MMSK 22-S-PNP-SA	0301444	
MMSK 22-S-NPN-SA	0301445	
<b>Reed Switches</b>		
RMS 22-S-M8	0377720	•
<b>Connection cables</b>		
KA BG05-L 3P-0300	0301652	
KA BG08-L 3P-0300-PNP	0301622	
KA BG08-L 3P-0500-PNP	0301623	
KA BW05-L 3P-0300	0301650	
KA BW08-L 3P-0300-NPN	0301602	
KA BW08-L 3P-0300-PNP	0301594	
KA BW08-L 3P-0500-NPN	9641116	
KA BW08-L 3P-0500-PNP	0301502	
<b>Cable extensions</b>		
KV BW08-SG08 3P-0030-PNP	0301495	
KV BW08-SG08 3P-0100-PNP	0301496	
KV BW08-SG08 3P-0200-PNP	0301497	

① Two sensors (closer/NO) are required for each gripper, plus extension cables as an option.

① Please note the minimum permitted bending radii for the sensor cables, which are generally 35 mm.

## Inductive proximity switches

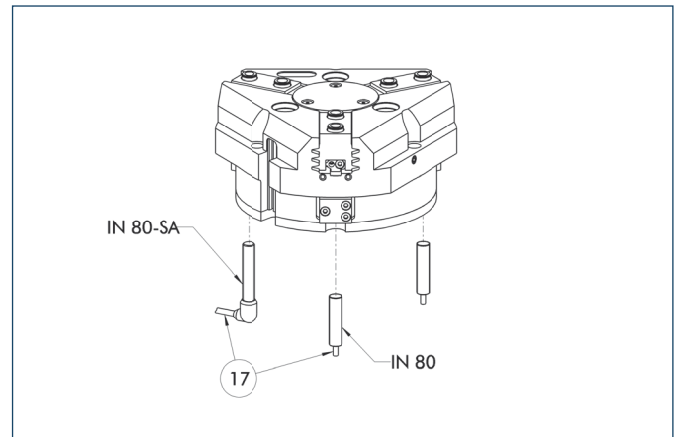

17 Cable outlet

End position monitoring for direct mounting

Description	ID	Recommended product
<b>Inductive proximity switches</b>		
IN 80-S-M8	0301478	•
IN 80-S-M12	0301578	
INK 80-S	0301550	
<b>Inductive proximity switch with lateral outlet</b>		
IN 80-S-M12-SA	0301587	
IN 80-S-M8-SA	0301483	•
INK 80-S-SA	0301566	
<b>Connection cables</b>		
KA BG08-L 3P-0300-PNP	0301622	
KA BG08-L 3P-0500-PNP	0301623	
KA BG12-L 3P-0500-PNP	30016369	
KA BW08-L 3P-0300-PNP	0301594	
KA BW08-L 3P-0500-PNP	0301502	
KA BW12-L 3P-0300-PNP	0301503	
KA BW12-L 3P-0500-PNP	0301507	
<b>Cable extensions</b>		
KV BG12-SG12 3P-0030-PNP	0301999	
KV BG12-SG12 3P-0060-PNP	0301998	
KV BW08-SG08 3P-0030-PNP	0301495	
KV BW08-SG08 3P-0100-PNP	0301496	
KV BW08-SG08 3P-0200-PNP	0301497	
KV BW12-SG12 3P-0030-PNP	0301595	
KV BW12-SG12 3P-0100-PNP	0301596	
KV BW12-SG12 3P-0200-PNP	0301597	

① Two sensors (closer/NO) are required for each gripper, plus extension cables as an option.

① Please note the minimum permitted bending radii for the sensor cables, which are generally 35 mm.

## Cylindrical Reed Switches

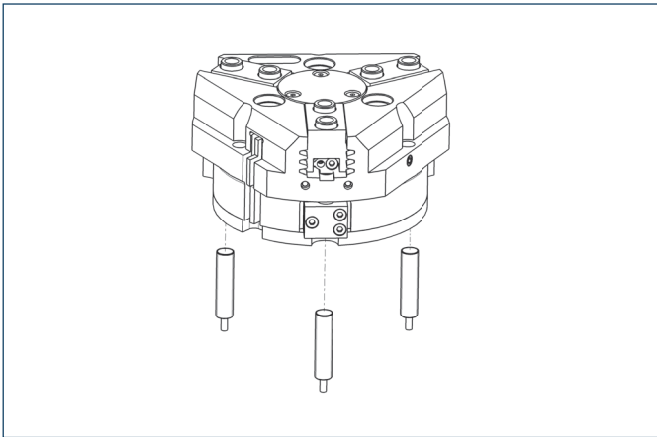

End position monitoring mounted with mounting kit

Description	ID
Mounting kit for proximity switch	
AS-RMS 80 PGN/PZN-plus 100/125	0377726
Reed Switches	
RMS 80-S-M8	0377721

- ① Two sensors (closer/NO) are required for each gripper, plus extension cables as an option.
- ① This mounting kit needs to be ordered optionally as an accessory.
- ① Please note the minimum permitted bending radii for the sensor cables, which are generally 35 mm.

## Analog position sensor

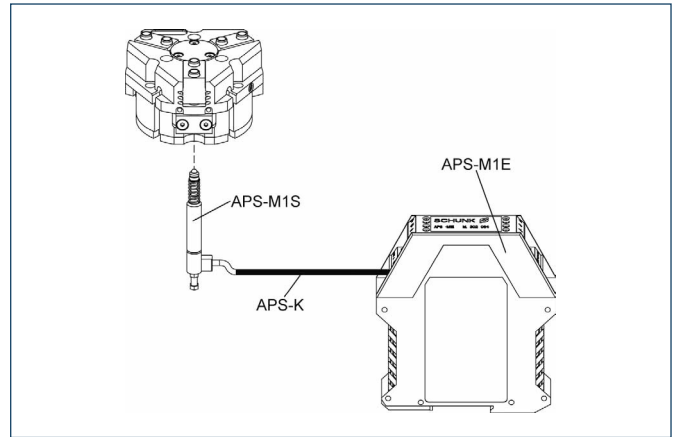

Analog multi position monitoring for any desired positions

Description	ID
Mounting kit	
AS-APS-M1-100/1	0302079
AS-APS-M1-100/2	0302080
Connection cables	
APS-K0200	0302066
APS-K0700	0302068
Electronic Processor	
APS-M1E	0302064
Sensor	
APS-M1S	0302062

- ① When using an APS system, for each gripper a mounting kit (AS-APS), an APS sensor (APS-M1S, incl. 3 m cable) as well as an electronics (APS-M1E) are required.
- ① An extension cable (APS-K) can be connected between the sensor and the electronics as an option. The max. cable length between the sensor and the electronics is 10 m, between the electronics and their control unit (PLC) it is max. 1 m.



You can find more detailed information and individual parts of the above-mentioned accessories in the "Accessories" catalog section.

## Flexible Position Sensor

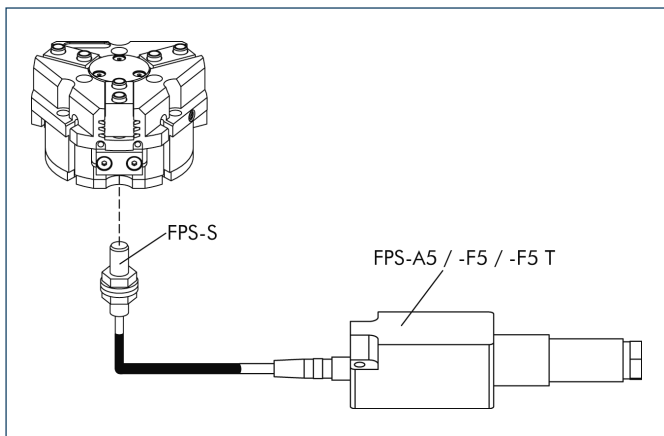

Flexible position monitoring of up to five positions

Description	ID
<b>Mounting kit for FPS</b>	
AS-PGN/PZN-plus 100/1	0301634
AS-PGN/PZN-plus 100/2, PZB 125	0301635
<b>Electronic Processor</b>	
FPS-F5	0301805
FPS-F5 T	0301807
<b>Sensor</b>	
FPS-S M8	0301704

① When using a FPS system, a FPS sensor (FPS-S) and a control unit (FPS-F5 / F5 T or A5) are required for each gripper as well as a mounting kit (AS), if listed. Cable extensions (KV) are available as options in the "Accessories" catalog section.

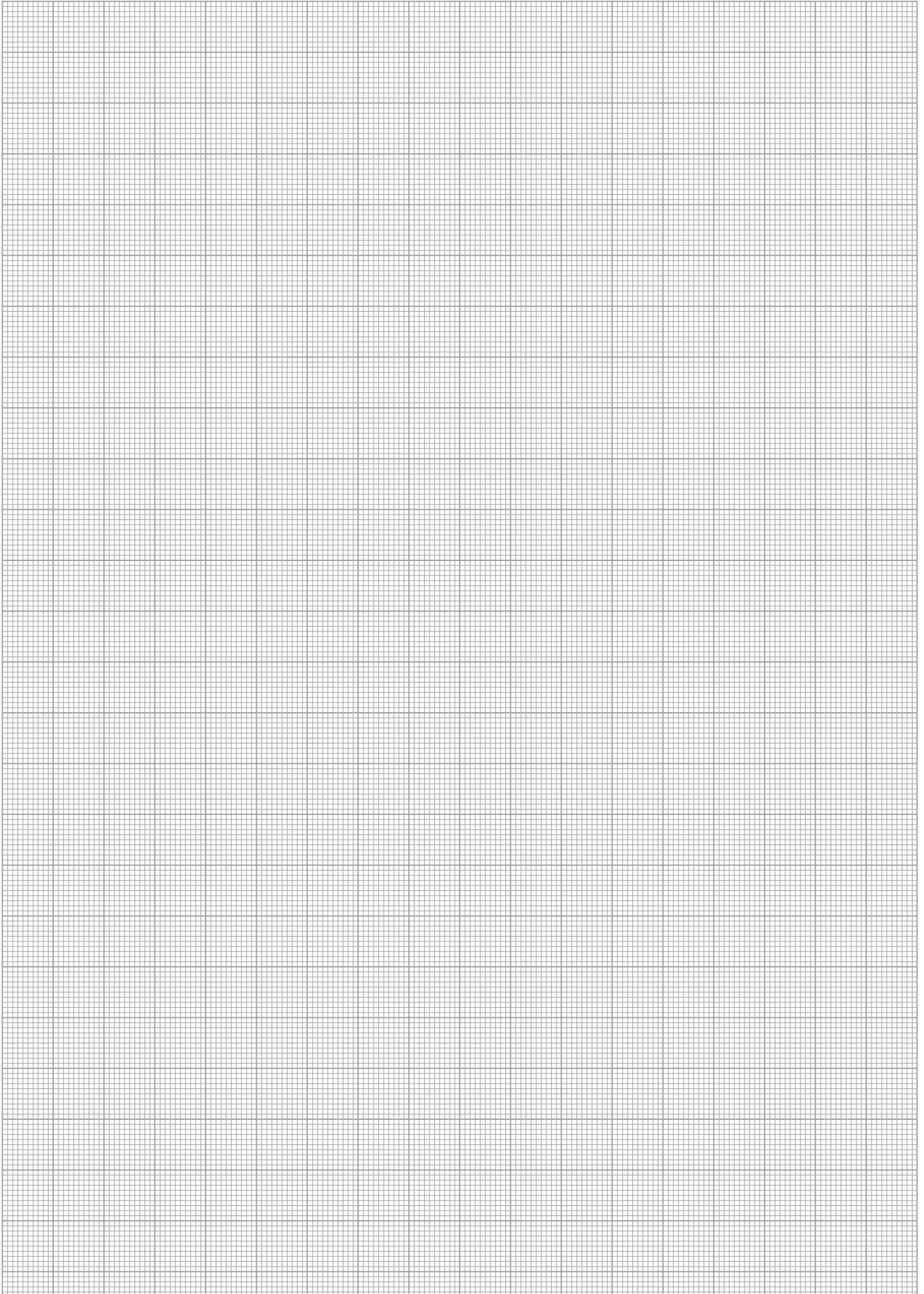



# PZN-plus 125

Pneumatic • 3-Finger Centric Gripper • Universal Gripper



## Gripping force, I.D. gripping

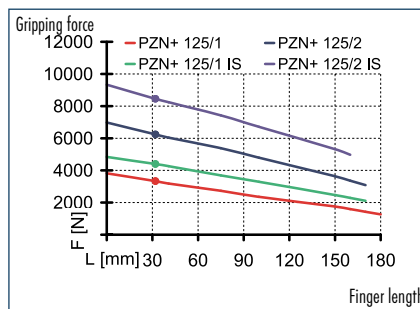

## Gripping force, O.D. gripping

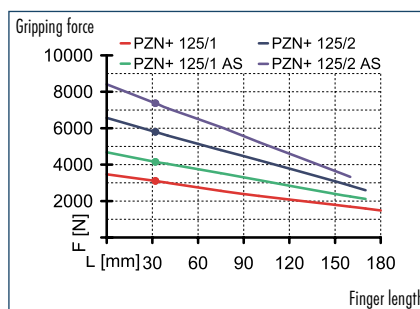

## Finger load

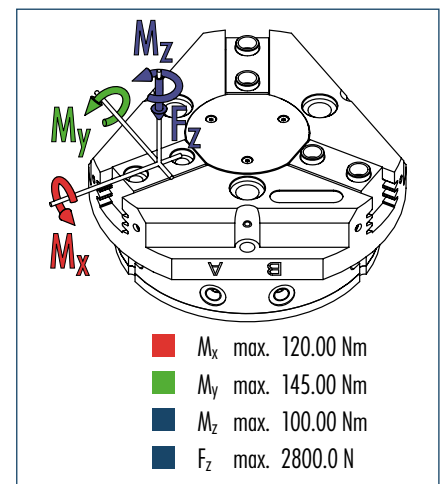

① The indicated moments and forces are static values, apply per base jaw and may occur simultaneously.  $M_y$  may arise in addition to the moment generated by the gripping force itself. If the max. permitted finger weight is exceeded, it is imperative to throttle the air pressure so that the jaw movement occurs without any hitting or bouncing. Service life may be reduced.

## Technical data

Description	PZN-plus 125-1	PZN-plus 125-2	PZN-plus 125-1-AS	PZN-plus 125-2-AS	PZN-plus 125-1-IS	PZN-plus 125-2-IS
ID	0303313	0303413	0303513	0303613	0303543	0303643
Stroke per finger [mm]	13	6	13	6	13	6
Closing force [N]	3100	5800	4150	7970		
Opening force [N]	3330	6240			4400	8450
Min. spring force [N]			1050	2170	1070	2210
Weight [kg]	2.47	2.47	3.34	3.34	3.34	3.34
Recommended workpiece weight [kg]	15.5	29	15.5	29	15.5	29
Air consumption per double stroke [cm <sup>3</sup> ]	230	230	383	383	383	383
Min./max. operating pressure [bar]	2/8	2/8	4/6.5	4/6.5	4/6.5	4/6.5
Nominal operating pressure [bar]	6	6	6	6	6	6
Closing/opening time [s]	0.2/0.2	0.2/0.2	0.17/0.35	0.17/0.35	0.35/0.17	0.35/0.17
Max. permitted finger length [mm]	180	170	170	160	170	160
Max. permitted weight per finger [kg]	2.1	2.1	2.1	2.1	2.1	2.1
IP class	40	40	40	40	40	40
Min./max. ambient temperature [°C]	-10/90	-10/90	-10/90	-10/90	-10/90	-10/90
Repeat accuracy [mm]	0.01	0.01	0.01	0.01	0.01	0.01
Cleanroom class						
ISO-classification 14644-1	5	5	5	5	5	5

## OPTIONS and their characteristics

Dust-protection version	37303313	37303413	37303513	37303613	37303543	37303643
IP class	64	64	64	64	64	64
Weight [kg]	2.9	2.9	3.7	3.7	3.7	3.7
Anti-corrosion version	38303313	38303413	38303513	38303613	38303543	38303643
High-temperature version	39303313	39303413	39303513	39303613	39303543	39303643
Min./max. ambient temperature [°C]	-10/130	-10/130	-10/130	-10/130	-10/130	-10/130
Force intensified version	PZN-plus 125-1-KVZ	PZN-plus 125-2-KVZ	PZN-plus 125-1-AS-KVZ		PZN-plus 125-1-IS-KVZ	
ID	0372204	0372214	0372224		0372244	
Closing force [N]	5580	10440	6630			
Opening force [N]	5935	11230			7005	
Weight [kg]	3.7	3.7	4.5		4.5	
Maximum pressure [bar]	8	8	6		6	
Max. permitted finger length [mm]	125	100	100		100	
Precision version	0303343	0303443	0303493	0303593		

## Main view

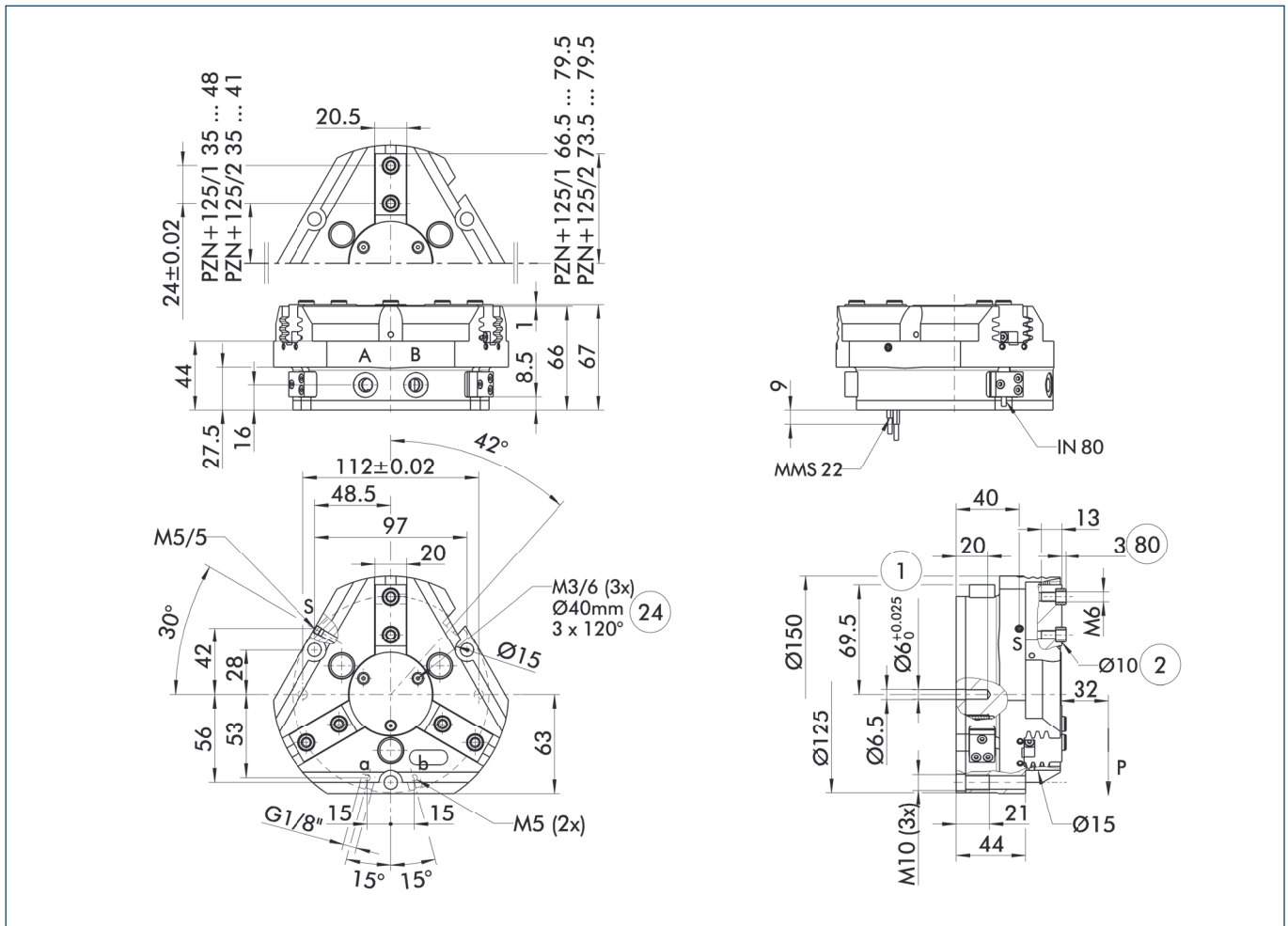

The drawing shows the gripper in the basic version with closed jaws, the dimensions do not include the options described below.

① The SDV-P pressure maintenance valve can also be used for I.D. or O.D. gripping alternatively or in addition to the spring-loaded, mechanical gripping force maintenance device (see "Accessories" catalog section).

A, a Main/direct connection, gripper opening  
 B, b Main/direct connection, gripper closing  
 S Air purge connection  
 ① Gripper connection  
 ② Finger connection

②④ Bolt circle  
 ⑧⑩ Depth of the centering sleeve hole in the matching part

## Hose-free direct connection

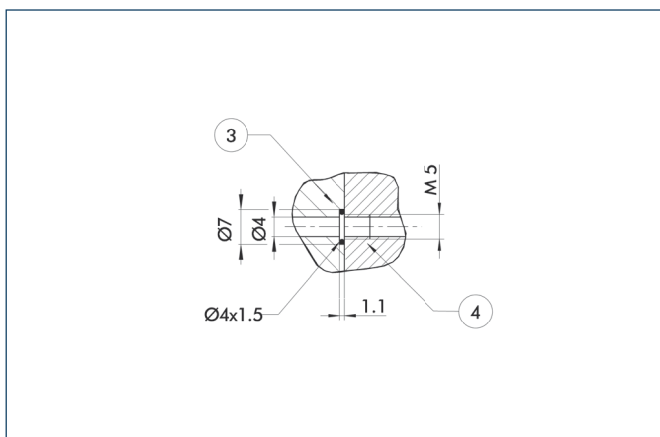

③ Adapter  
 ④ Gripper

The direct connection is used for supplying compressed air without hoses. Instead, the pressure medium is fed through bore-holes in the mounting plate.

## AS/IS gripping force maintenance device

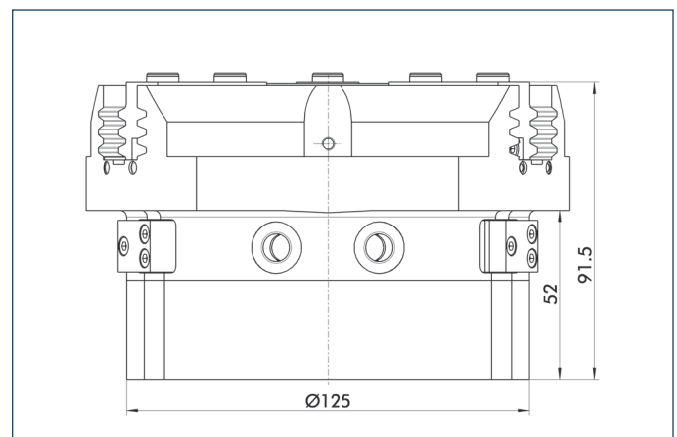

The mechanical gripping force maintenance device ensures a minimum gripping force even in case of pressure drop. This acts as closing force in the AS version, and as opening force in the IS version. In addition, the gripping force maintenance device can also be used for increasing the gripping force or for single-acting gripping.

# PZN-plus 125

Pneumatic • 3-Finger Centric Gripper • Universal Gripper

## Dust-protection version

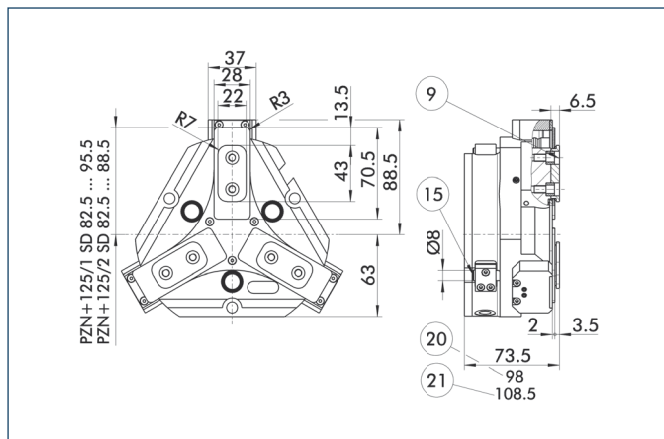

- ⑨ For mounting screw connection diagram, see basic version
- ⑮ Sealing bolt
- ⑳ For AS / IS version
- ㉑ Applies for KVZ version

The "dust-protection" option increases the degree of protection against penetrating substances. The screw connection diagram shifts by the height of the intermediate jaw. The finger length is still measured from the upper edge of the gripper housing.

## Force intensified version

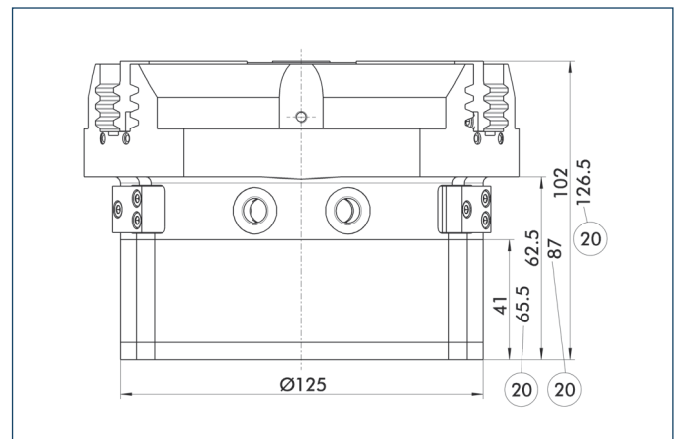

- ㉒ For AS / IS version

The KVZ cylinder increases the gripping forces during opening and closing. A second, in series-connected piston also increases the force on the wedge hook. The full gripping force shown in the data table is sometimes only reached after a few hundred gripping cycles. Please consider that grippers which are equipped with a gripping force maintenance device (AS / IS) are higher.

## Precision version

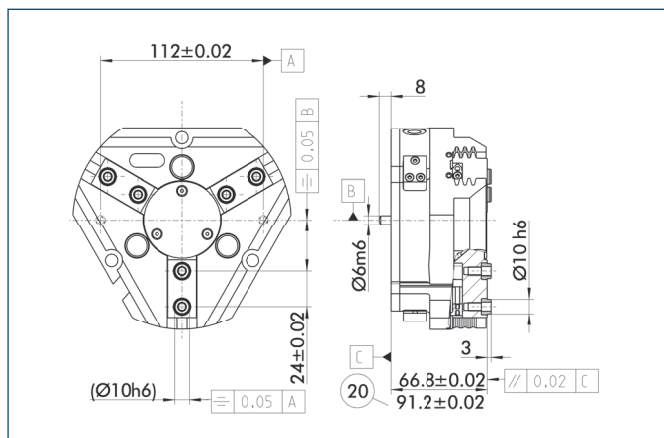

- ㉓ For AS / IS version

The indicated tolerances just refer to the types of precision versions shown in the chart of technical specifications. All other types of precision versions are available on request.

## Spring-loaded pressure piece

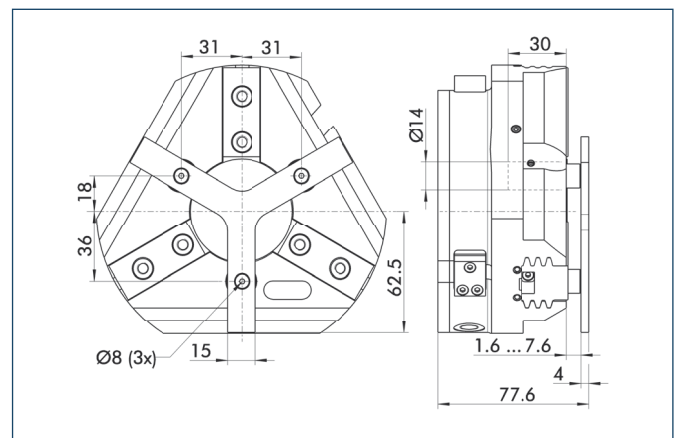

For spring-supported positioning of the workpiece against a stop after the gripper has opened. Especially developed for loading machines.

Description	ID	Stroke	Min. force
Spring-loaded pressure piece			
A-PZN-plus/DPZ-plus 125	0303723	6 mm	105 N

- ① The pressure piece cannot be combined with the dust-protection version. Please contact us if you require a special pressure piece.

## Protection cover

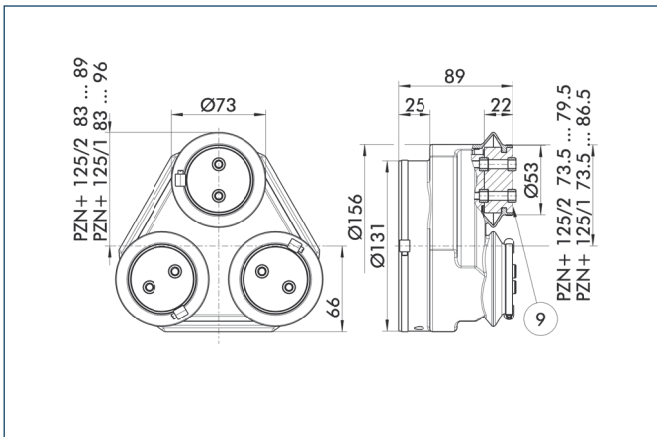

⑨ For mounting screw connection diagram, see basic version

The HUE protective cover completely protects the gripper against external influences up to IP65 if an additional sealing of the cover bottom is provided as part of the application. The mounting diagram shifts by the height of the intermediate jaw.

Description	ID	Cleanroom class ISO-classification 14644-1
Protection cover		
HUE PZN-plus 125	0303483	2

## Quick-change Jaw System

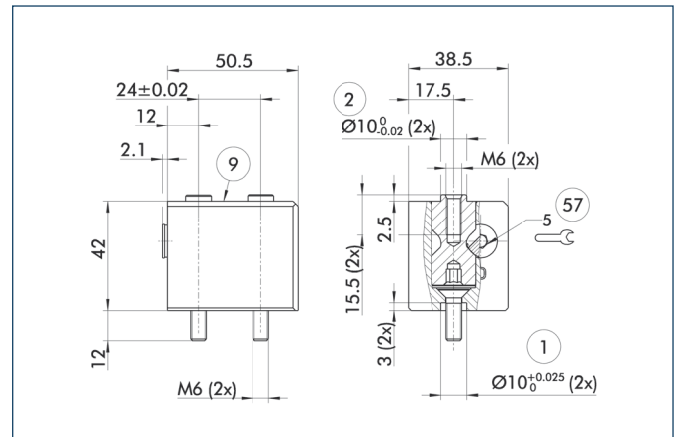

① Gripper connection  
② Finger connection  
⑨ For mounting screw connection diagram, see basic version

⑤7 Locking

The BSWS quick-change jaw system enables top jaws to be changed on the gripper manually and rapidly. An adapter (BSWS-A) and a base (BSWS-B) are required for each gripper jaw.

For a reverse assembly without height set-up, one adapter (BSWS-A) and a kit (BSWS-U) per gripper jaw are required. Another effect of the BSWS-U is, that there are no disturbing fastening bores in the finger contour.

Description	ID
Quick-change Jaw System adapter	
BSWS-A 125	0303028
Quick-change Jaw System base	
BSWS-B 125	0303029
Quick-change Jaw System reversed	
BSWS-U 125	0303044



You can find more detailed information and individual parts of the above-mentioned accessories in the "Accessories" catalog section.

### Universal intermediate jaw

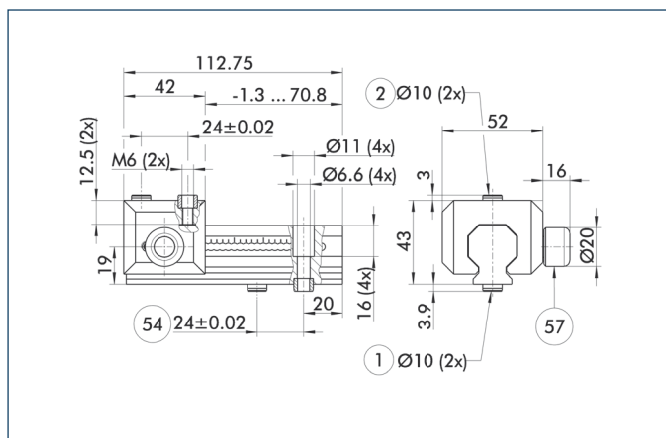

- ① Gripper connection
- ② Finger connection
- ⑤④ Optional right or left connection
- ⑤⑦ Locking

The universal intermediate jaw allows fast tool-free and reliable plugging and shifting of top jaws at the gripper.

Description	ID	Grid dimension
Universal intermediate jaw		
UZB 125	0300045	3 mm
UZB-S 125	5518273	3 mm

- ① The slide UZB-S can be removed completely and has to be ordered separately. Moreover, it allows a fast jaw change.

### Force measuring jaws

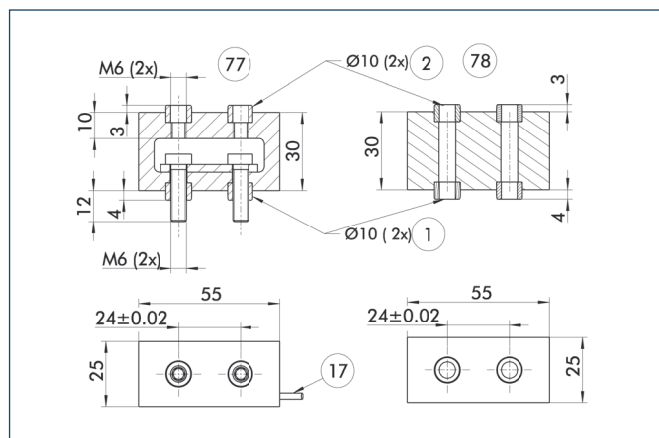

- ① Gripper connection
- ② Finger connection
- ①⑦ Cable outlet
- ⑦⑦ Active intermediate jaws
- ⑦⑧ Passive intermediate jaws

Force measuring jaws measure gripping forces, but can also determine workpiece weights or dimensional deviations. There are active and passive intermediate jaws (FMS-ZBA or FMS-ZBP). At least one active force measuring jaw is required per gripper, the rest can be passive. For each active jaw, a FMS-A1 control unit and a FMS-A connection cable are required.

Description	ID
<b>Active intermediate jaws</b>	
FMS-ZBA 125	0301838
<b>Passive intermediate jaws</b>	
FMS-ZBP 125	0301839
<b>Electronic Processor</b>	
FMS-A1	0301810
<b>Connection cables</b>	
FMS-AK0200	0301820
FMS-AK0500	0301821
FMS-AK1000	0301822
FMS-AK2000	0301823

### Finger blanks

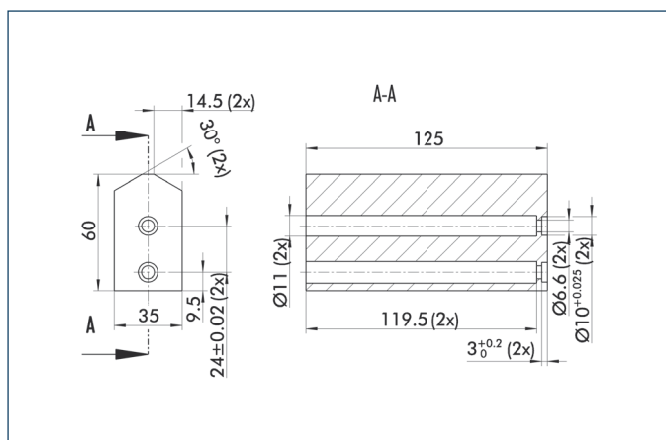

Finger blanks for customized subsequent machining

Description	ID	Material	Scope of delivery
Finger blanks			
ABR-plus 125	0300013	Aluminum	1
SBR-plus 125	0300023	16 MnCr 5	1

You can find more detailed information and individual parts of the above-mentioned accessories in the "Accessories" catalog section.

### Tolerance compensation unit

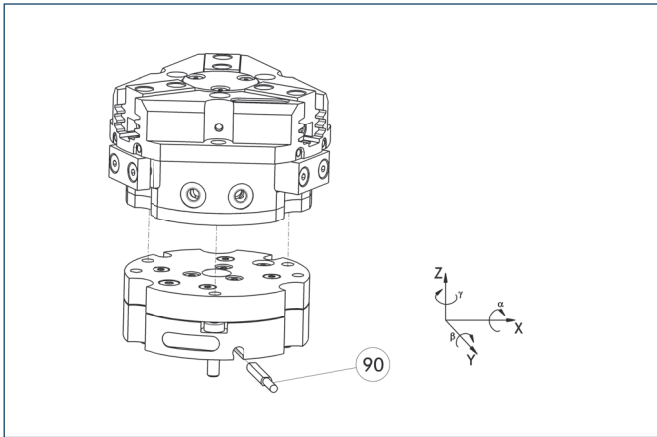

90 Monitoring of locking

Grippers can be directly mounted without an adapter plate. Tolerance compensation unit and gripper have an identical screw connection diagram. Therefore the tolerance compensation units can be assembled later. Please consider the additional assembly height of the tolerance compensation unit. For details see catalog "Robot Accessories".

Description	ID	Locking	Deflection
<b>Compensation unit</b>			
TCU-125-3-MV-Z	0324820	Yes	
TCU-125-3-OV-Z	0324821	No	

### Compensation unit with spring reset

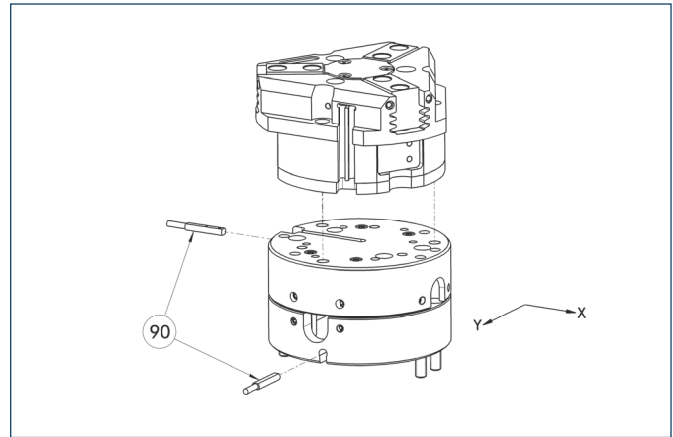

90 Monitoring

Grippers can be directly mounted without using an adapter plate. For details see our catalog "Robot Accessories".

Description	ID	Compensation travel	Reset force
<b>Compensation unit</b>			
AGE-F-XY-080-1	0324960	±5 mm	28.3 N
AGE-F-XY-080-2	0324961	±5 mm	42.5 N
AGE-F-XY-080-3	0324962	±5 mm	47.6 N

### Programmable magnetic switch

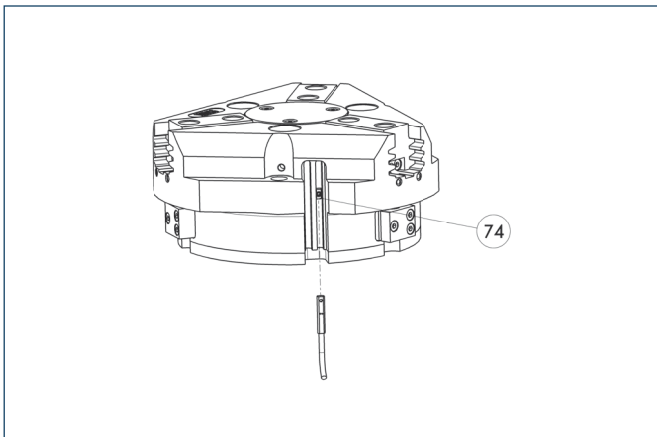

74 Stop for MMS-P

Position monitoring with two programmable positions per sensor. The end position monitoring is mounted in the C-slot.

Description	ID	Recommended product
<b>Programmable magnetic switch</b>		
MMS-P 22-S-M8-PNP	0301370	•
MMSK-P 22-S-PNP	0301371	
<b>Connection cables</b>		
KA BG08-L 4P-0500	0307767	
KA BG08-L 4P-1000	0307768	
KA BW08-L 4P-0500	0307765	
KA BW08-L 4P-1000	0307766	
<b>Sensor Distributor</b>		
V2-M8-4P-2XM8-3P	0301380	

① Please note the minimum permitted bending radii for the sensor cables, which are generally 35 mm.

① Per gripper one sensor (closer/NO) is required, optionally a cable extension.

### Electronic magnetic switches

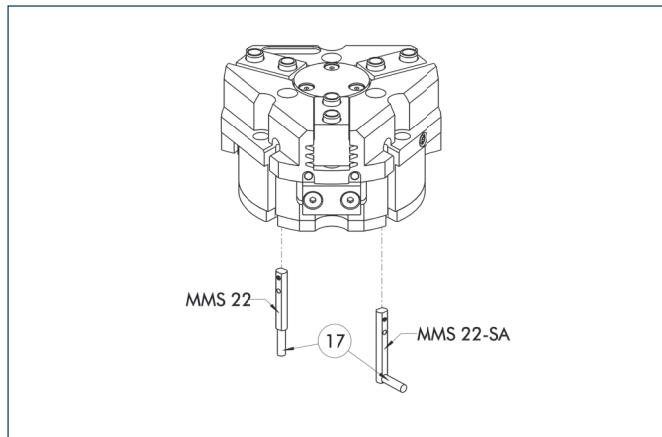

17 Cable outlet

End position monitoring for mounting in the C-slot

Description	ID	Recommended product
<b>Electronic magnetic switches</b>		
MMS 22-S-M5-PNP	0301438	
MMS 22-S-M5-NPN	0301439	
MMS 22-S-M8-PNP	0301432	•
MMS 22-S-M8-NPN	0301433	
MMSK 22-S-PNP	0301434	
MMSK 22-S-NPN	0301435	
<b>Electronic magnetic switches with lateral cable outlet</b>		
MMS 22-S-M5-PNP-SA	0301448	
MMS 22-S-M5-NPN-SA	0301449	
MMS 22-S-M8-PNP-SA	0301442	•
MMS 22-S-M8-NPN-SA	0301443	
MMSK 22-S-PNP-SA	0301444	
MMSK 22-S-NPN-SA	0301445	
<b>Reed Switches</b>		
RMS 22-S-M8	0377720	•
<b>Connection cables</b>		
KA BG05-L 3P-0300	0301652	
KA BG08-L 3P-0300-PNP	0301622	
KA BG08-L 3P-0500-PNP	0301623	
KA BW05-L 3P-0300	0301650	
KA BW08-L 3P-0300-NPN	0301602	
KA BW08-L 3P-0300-PNP	0301594	
KA BW08-L 3P-0500-NPN	9641116	
KA BW08-L 3P-0500-PNP	0301502	
<b>Cable extensions</b>		
KV BW08-SG08 3P-0030-PNP	0301495	
KV BW08-SG08 3P-0100-PNP	0301496	
KV BW08-SG08 3P-0200-PNP	0301497	

① Two sensors (closer/NO) are required for each gripper, plus extension cables as an option.

① Please note the minimum permitted bending radii for the sensor cables, which are generally 35 mm.

### Inductive proximity switches

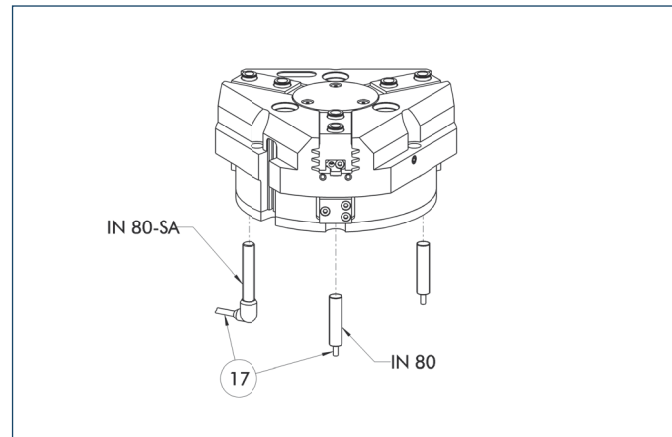

17 Cable outlet

End position monitoring for direct mounting

Description	ID	Recommended product
<b>Inductive proximity switches</b>		
IN 80-S-M8	0301478	•
IN 80-S-M12	0301578	
INK 80-S	0301550	
<b>Inductive proximity switch with lateral outlet</b>		
IN 80-S-M12-SA	0301587	
IN 80-S-M8-SA	0301483	•
INK 80-S-SA	0301566	
<b>Connection cables</b>		
KA BG08-L 3P-0300-PNP	0301622	
KA BG08-L 3P-0500-PNP	0301623	
KA BG12-L 3P-0500-PNP	30016369	
KA BW08-L 3P-0300-PNP	0301594	
KA BW08-L 3P-0500-PNP	0301502	
KA BW12-L 3P-0300-PNP	0301503	
KA BW12-L 3P-0500-PNP	0301507	
<b>Cable extensions</b>		
KV BG12-SG12 3P-0030-PNP	0301999	
KV BG12-SG12 3P-0060-PNP	0301998	
KV BW08-SG08 3P-0030-PNP	0301495	
KV BW08-SG08 3P-0100-PNP	0301496	
KV BW08-SG08 3P-0200-PNP	0301497	
KV BW12-SG12 3P-0030-PNP	0301595	
KV BW12-SG12 3P-0100-PNP	0301596	
KV BW12-SG12 3P-0200-PNP	0301597	

① Two sensors (closer/NO) are required for each gripper, plus extension cables as an option.

① Please note the minimum permitted bending radii for the sensor cables, which are generally 35 mm.

## Cylindrical Reed Switches

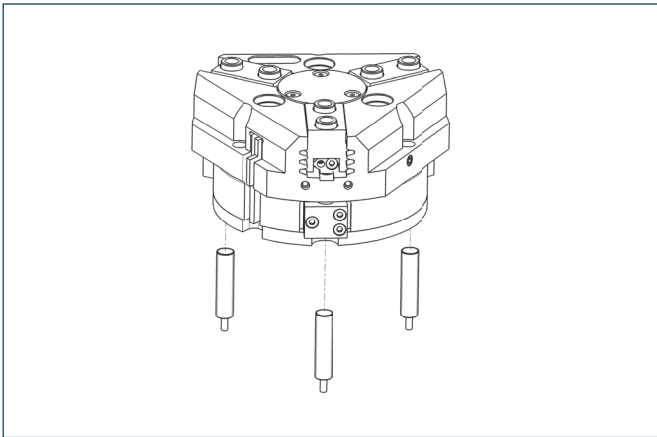

End position monitoring mounted with mounting kit

Description	ID
Mounting kit for proximity switch	
AS-RMS 80 PGN/PZN-plus 100/125	0377726
Reed Switches	
RMS 80-S-M8	0377721

- ① Two sensors (closer/NO) are required for each gripper, plus extension cables as an option.
- ① This mounting kit needs to be ordered optionally as an accessory.
- ① Please note the minimum permitted bending radii for the sensor cables, which are generally 35 mm.

## Analog position sensor

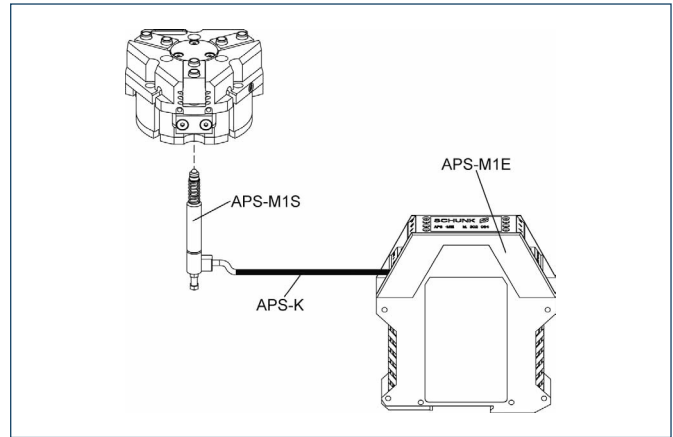

Analog multi position monitoring for any desired positions

Description	ID
Mounting kit	
AS-APS-M1-125/1	0302081
AS-APS-M1-125/2	0302082
Connection cables	
APS-K0200	0302066
APS-K0700	0302068
Electronic Processor	
APS-M1E	0302064
Sensor	
APS-M1S	0302062

- ① When using an APS system, for each gripper a mounting kit (AS-APS), an APS sensor (APS-M1S, incl. 3 m cable) as well as an electronics (APS-M1e) are required.
- ① An extension cable (APS-K) can be connected between the sensor and the electronics as an option. The max. cable length between the sensor and the electronics is 10 m, between the electronics and their control unit (PLC) it is max. 1 m.



## Flexible Position Sensor

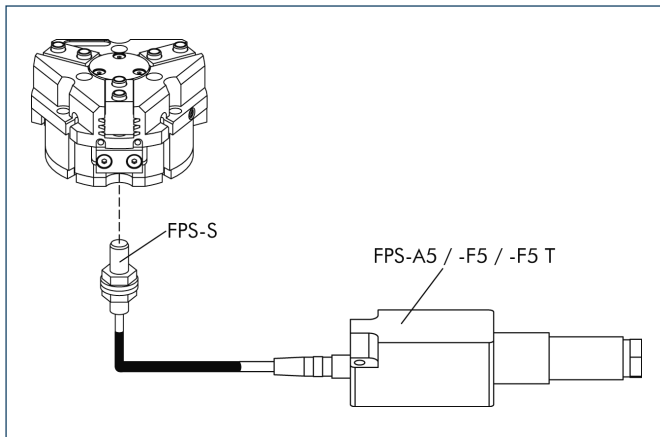

Flexible position monitoring of up to five positions

Description	ID
<b>Mounting kit for FPS</b>	
AS-PGN/PZN-plus 125/1, PZB 160	<b>0301636</b>
AS-PGN/PZN-plus 125/2	<b>0301637</b>
<b>Electronic Processor</b>	
FPS-F5	<b>0301805</b>
FPS-F5 T	<b>0301807</b>
<b>Sensor</b>	
FPS-S M8	<b>0301704</b>

① When using a FPS system, a FPS sensor (FPS-S) and a control unit (FPS-F5 / F5 T or A5) are required for each gripper as well as a mounting kit (AS), if listed. Cable extensions (KV) are available as options in the "Accessories" catalog section.

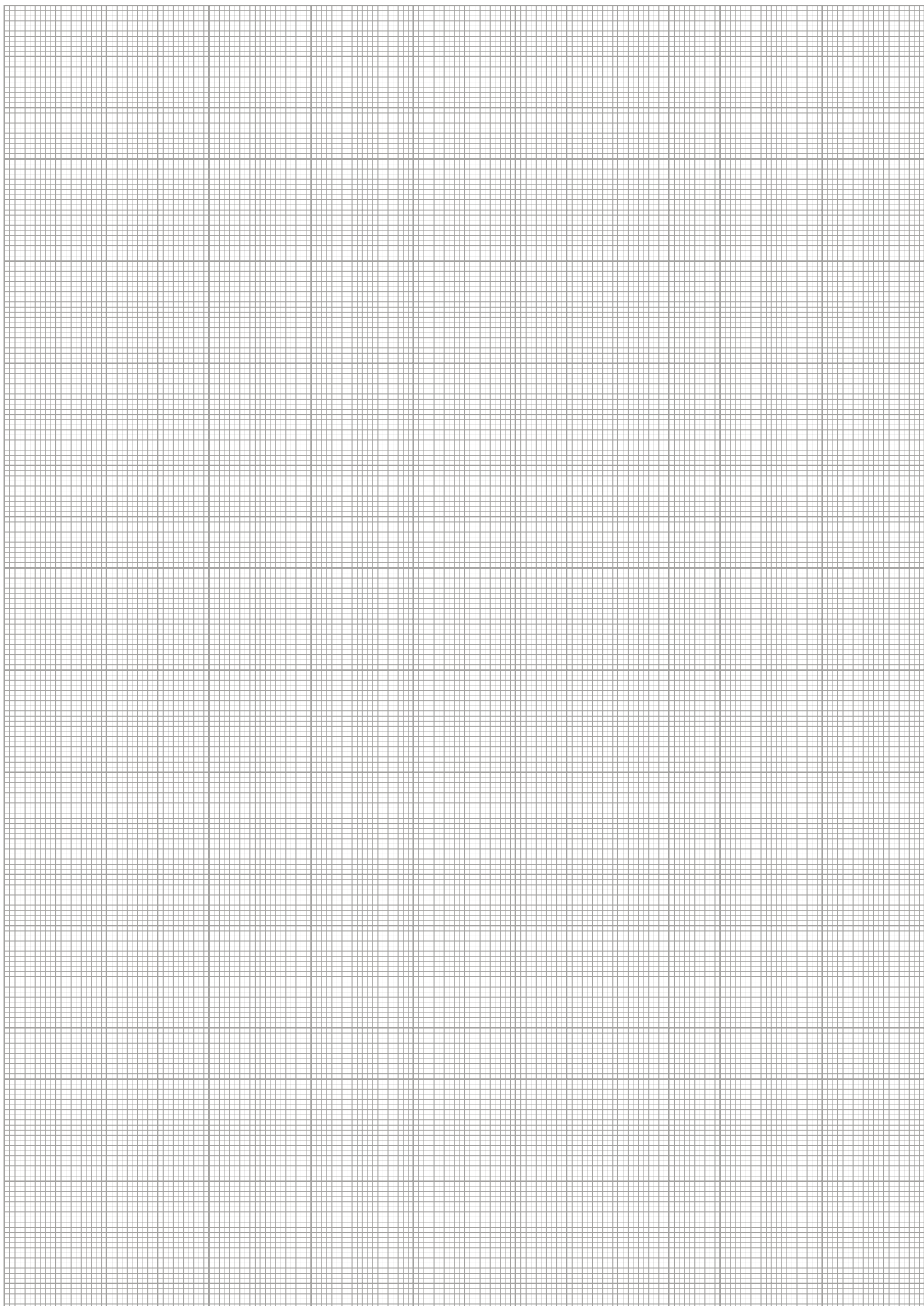

# PZN-plus 160

Pneumatic • 3-Finger Centric Gripper • Universal Gripper



## Gripping force, I.D. gripping

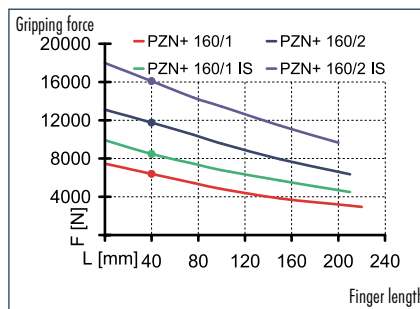

## Gripping force, O.D. gripping

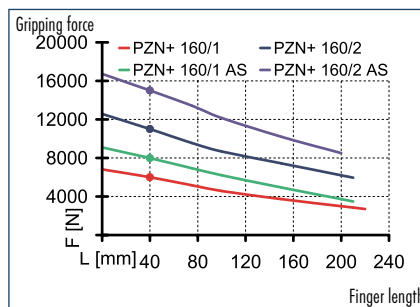

## Finger load

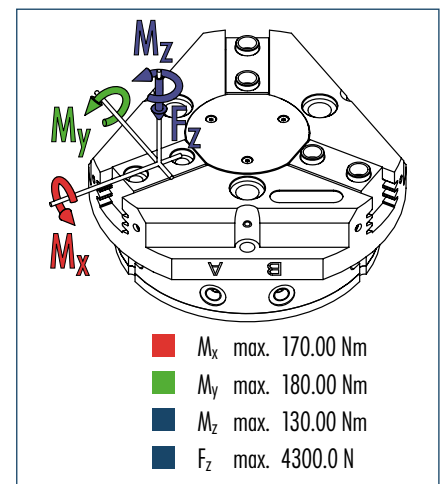

① The indicated moments and forces are static values, apply per base jaw and may occur simultaneously.  $M_y$  may arise in addition to the moment generated by the gripping force itself. If the max. permitted finger weight is exceeded, it is imperative to throttle the air pressure so that the jaw movement occurs without any hitting or bouncing. Service life may be reduced.

## Technical data

Description	PZN-plus 160-1	PZN-plus 160-2	PZN-plus 160-1-AS	PZN-plus 160-2-AS	PZN-plus 160-1-IS	PZN-plus 160-2-IS
ID	0303314	0303414	0303514	0303614	0303544	0303644
Stroke per finger [mm]	16	8	16	8	16	8
Closing force [N]	6000	11000	7990	15010		
Opening force [N]	6390	11750			8480	16090
Min. spring force [N]			1990	4010	2090	4340
Weight [kg]	5.6	5.6	8	8	8	8
Recommended workpiece weight [kg]	30	55	30	55	30	55
Air consumption per double stroke [cm <sup>3</sup> ]	520	520	875	875	875	875
Min./max. operating pressure [bar]	2/8	2/8	4/6.5	4/6.5	4/6.5	4/6.5
Nominal operating pressure [bar]	6	6	6	6	6	6
Closing/opening time [s]	0.5/0.5	0.5/0.5	0.4/0.8	0.4/0.8	0.8/0.4	0.8/0.4
Max. permitted finger length [mm]	220	210	210	200	210	200
Max. permitted weight per finger [kg]	3.5	3.5	3.5	3.5	3.5	3.5
IP class	40	40	40	40	40	40
Min./max. ambient temperature [°C]	-10/90	-10/90	-10/90	-10/90	-10/90	-10/90
Repeat accuracy [mm]	0.02	0.02	0.02	0.02	0.02	0.02
Cleanroom class						
ISO-classification 14644-1	5	5	5	5	5	5

## OPTIONS and their characteristics

Dust-protection version	37303314	37303414	37303514	37303614	37303544	37303644
IP class	64	64	64	64	64	64
Weight [kg]	6.5	6.5	8.9	8.9	8.9	8.9
Anti-corrosion version	38303314	38303414	38303514	38303614	38303544	38303644
High-temperature version	39303314	39303414	39303514	39303614	39303544	39303644
Min./max. ambient temperature [°C]	-10/130	-10/130	-10/130	-10/130	-10/130	-10/130
Force intensified version	PZN-plus 160-1-KVZ	PZN-plus 160-2-KVZ	PZN-plus 160-1-AS-KVZ		PZN-plus 160-1-IS-KVZ	
ID	0372205	0372215	0372225		0372245	
Closing force [N]	10800	19800	12730			
Opening force [N]	11500	21150			13590	
Weight [kg]	7.8	7.8	9.6		9.6	
Maximum pressure [bar]	8	8	6		6	
Max. permitted finger length [mm]	125	100	100		100	
Precision version	0303344	0303444	0303494	0303594		

## Main view

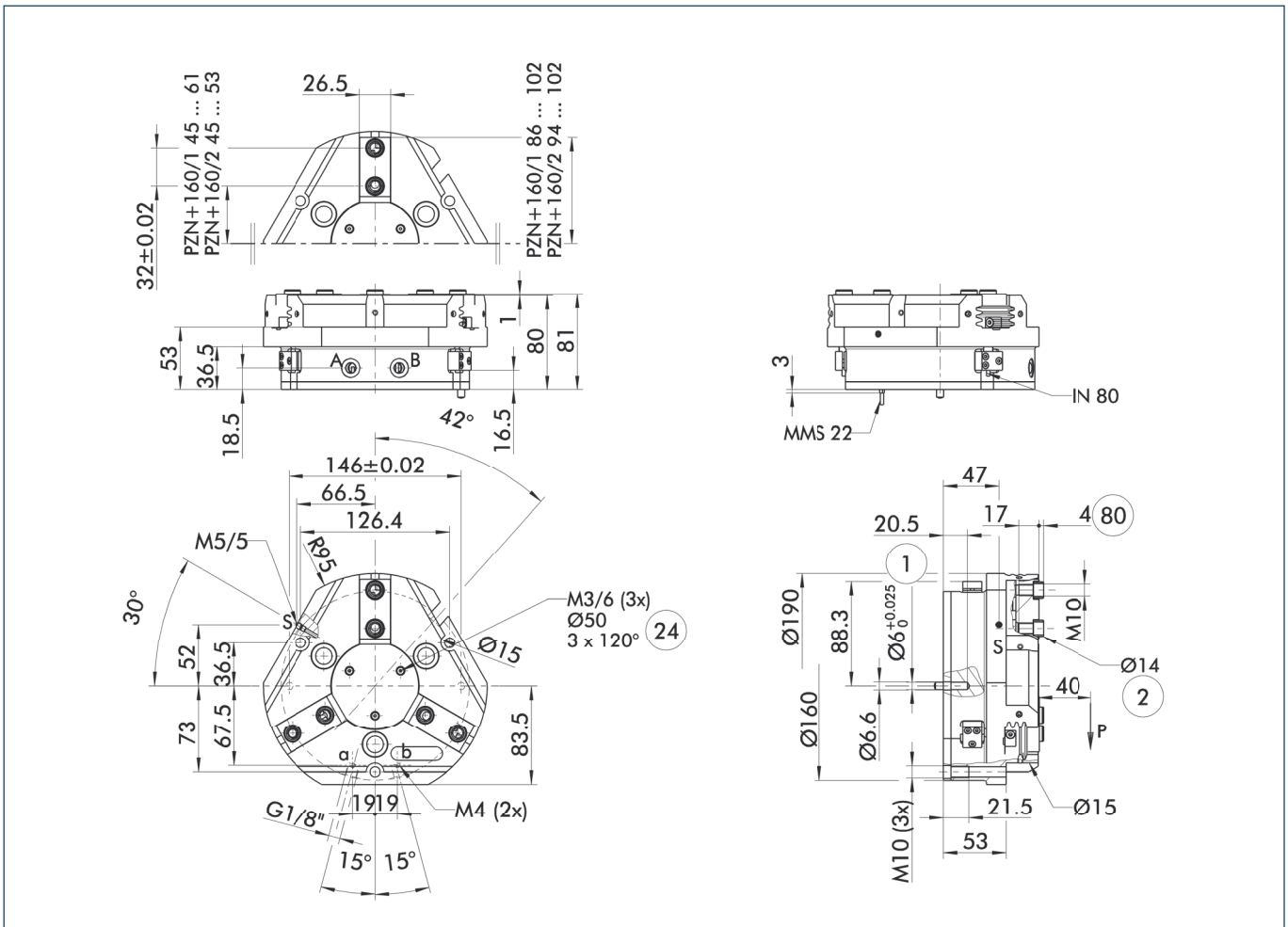

The drawing shows the gripper in the basic version with closed jaws, the dimensions do not include the options described below.

① The SDV-P pressure maintenance valve can also be used for I.D. or O.D. gripping alternatively or in addition to the spring-loaded, mechanical gripping force maintenance device (see "Accessories" catalog section).

A, a Main/direct connection, gripper opening

B, b Main/direct connection, gripper closing

S Air purge connection

① Gripper connection

② Finger connection

②④ Bolt circle

⑧⑩ Depth of the centering sleeve hole in the matching part

## Hose-free direct connection

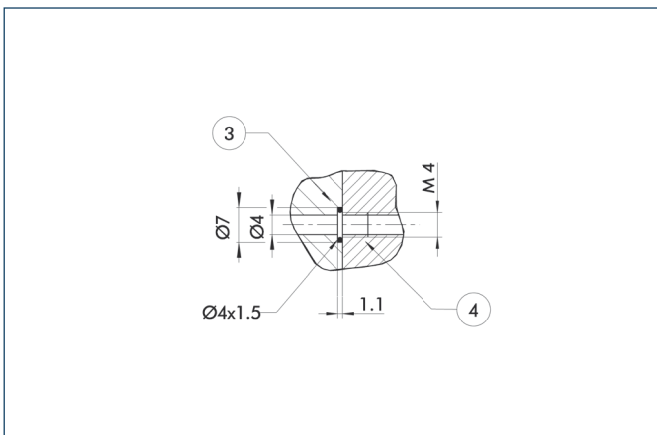

③ Adapter

④ Gripper

The direct connection is used for supplying compressed air without hoses. Instead, the pressure medium is fed through bore-holes in the mounting plate.

## AS/IS gripping force maintenance device

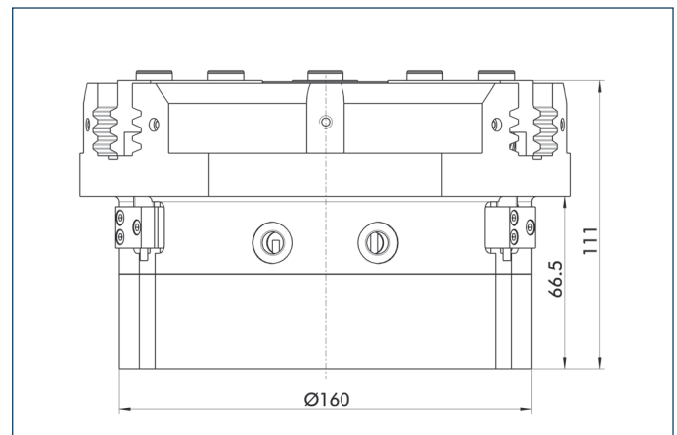

The mechanical gripping force maintenance device ensures a minimum gripping force even in case of pressure drop. This acts as closing force in the AS version, and as opening force in the IS version. In addition, the gripping force maintenance device can also be used for increasing the gripping force or for single-acting gripping.

# PZN-plus 160

Pneumatic • 3-Finger Centric Gripper • Universal Gripper

## Dust-protection version

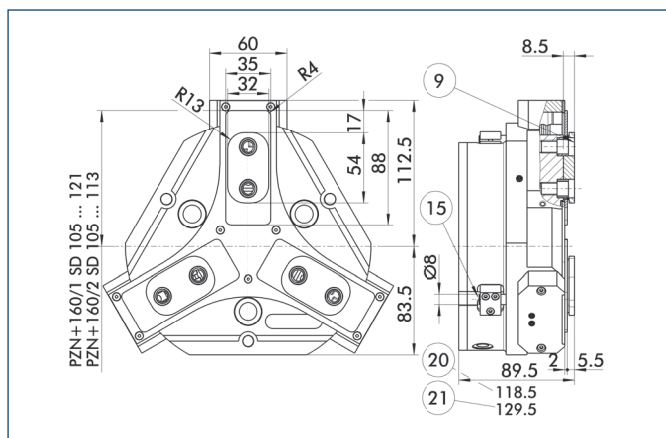

- ⑨ For mounting screw connection diagram, see basic version
- ⑮ Sealing bolt
- ⑳ For AS / IS version
- ㉑ Applies for KVZ version

The "dust-protection" option increases the degree of protection against penetrating substances. The screw connection diagram shifts by the height of the intermediate jaw. The finger length is still measured from the upper edge of the gripper housing.

## Force intensified version

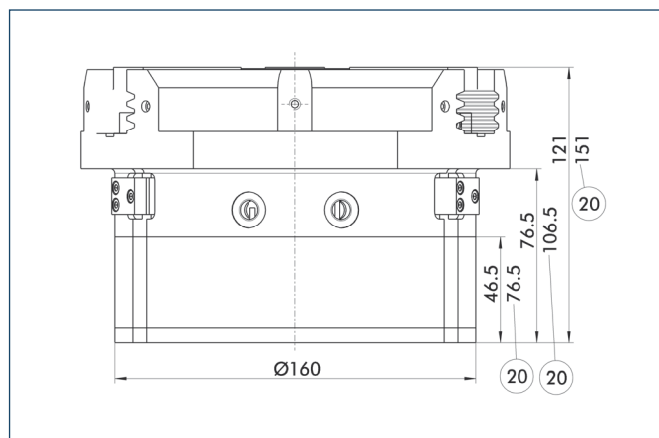

- ㉑ For AS / IS version
- The KVZ cylinder increases the gripping forces during opening and closing. A second, in series-connected piston also increases the force on the wedge hook. The full gripping force shown in the data table is sometimes only reached after a few hundred gripping cycles. Please consider that grippers which are equipped with a gripping force maintenance device (AS / IS) are higher.

## Precision version

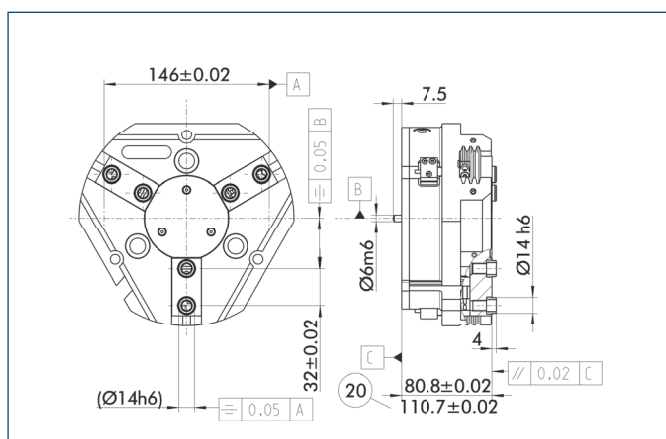

- ㉑ For AS / IS version
- The indicated tolerances just refer to the types of precision versions shown in the chart of technical specifications. All other types of precision versions are available on request.

## Spring-loaded pressure piece

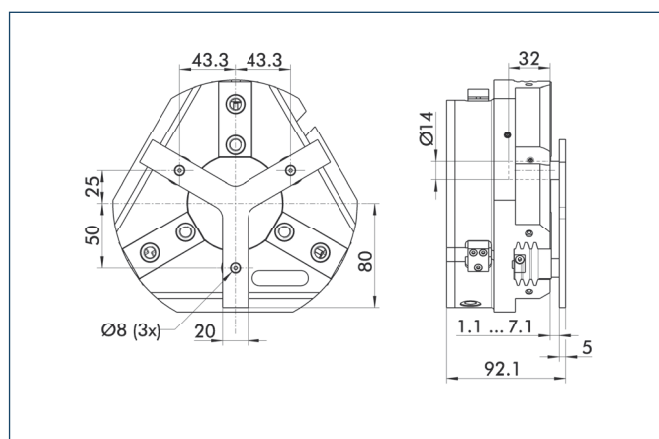

For spring-supported positioning of the workpiece against a stop after the gripper has opened. Especially developed for loading machines.

Description	ID	Stroke	Min. force
Spring-loaded pressure piece			
A-PZN-plus/DPZ-plus 160	0303724	6 mm	205 N

- ① The pressure piece cannot be combined with the dust-protection version. Please contact us if you require a special pressure piece.

## Protection cover

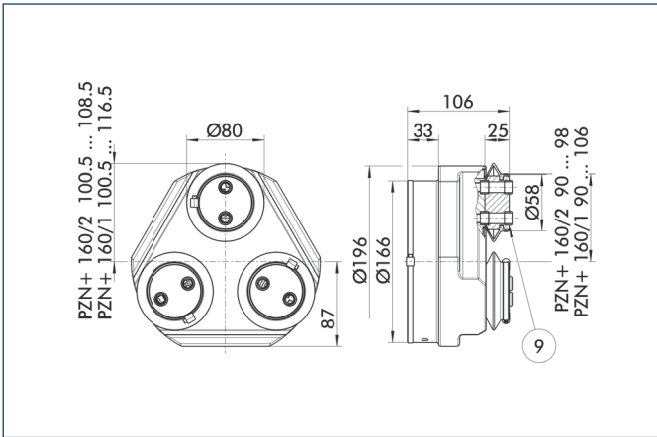

⑨ For mounting screw connection diagram, see basic version

The HUE protective cover completely protects the gripper against external influences up to IP65 if an additional sealing of the cover bottom is provided as part of the application. The mounting diagram shifts by the height of the intermediate jaw.

Description	ID	Cleanroom class ISO-classification 14644-1
Protection cover		
HUE PZN-plus 160	0303484	2

## Quick-change Jaw System

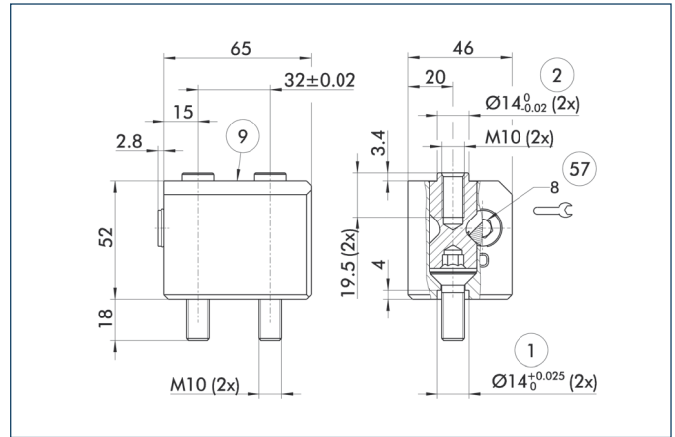

① Gripper connection  
② Finger connection  
⑨ For mounting screw connection diagram, see basic version  
57 Locking

The BSWS quick-change jaw system enables top jaws to be changed on the gripper manually and rapidly. An adapter (BSWS-A) and a base (BSWS-B) are required for each gripper jaw.

For a reverse assembly without height set-up, one adapter (BSWS-A) and a kit (BSWS-U) per gripper jaw are required. Another effect of the BSWS-U is, that there are no disturbing fastening bores in the finger contour.

Description	ID
Quick-change Jaw System adapter	
BSWS-A 160	0303030
Quick-change Jaw System base	
BSWS-B 160	0303031
Quick-change Jaw System reversed	
BSWS-U 160	0303045



You can find more detailed information and individual parts of the above-mentioned accessories in the "Accessories" catalog section.

# PZN-plus 160

Pneumatic • 3-Finger Centric Gripper • Universal Gripper

## Universal intermediate jaw

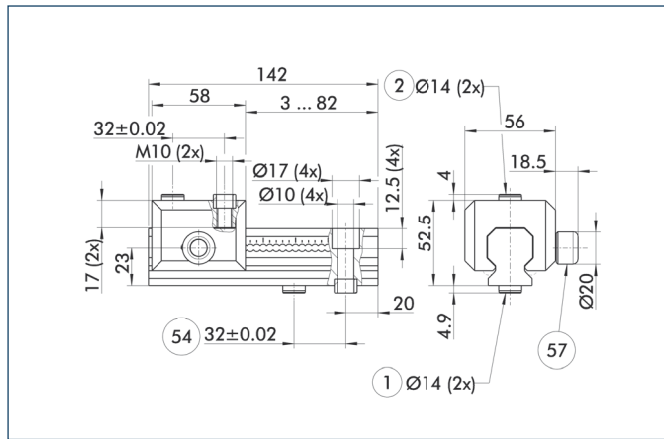

- ① Gripper connection
- ② Finger connection
- ⑤④ Optional right or left connection
- ⑤⑦ Locking

The universal intermediate jaw allows fast tool-free and reliable plugging and shifting of top jaws at the gripper.

Description	ID	Grid dimension
Universal intermediate jaw		
UZB 160	0300046	4 mm
UZB-S 160	5518274	4 mm

- ① The slide UZB-S can be removed completely and has to be ordered separately. Moreover, it allows a fast jaw change.

## Force measuring jaws

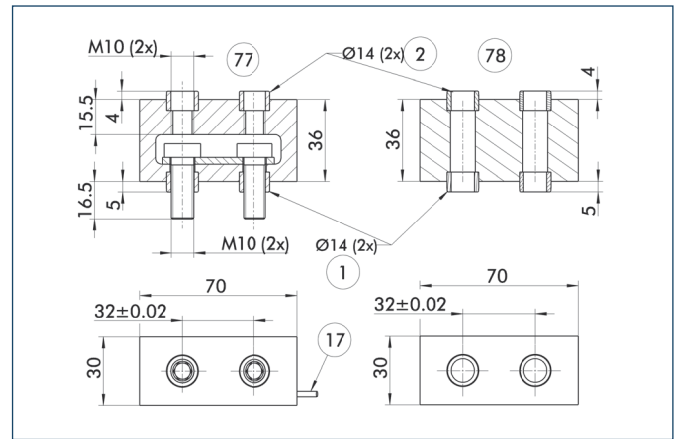

- ① Gripper connection
- ② Finger connection
- ①⑦ Cable outlet
- ⑦⑦ Active intermediate jaws
- ⑦⑧ Passive intermediate jaws

Force measuring jaws measure gripping forces, but can also determine workpiece weights or dimensional deviations. There are active and passive intermediate jaws (FMS-ZBA or FMS-ZBP). At least one active force measuring jaw is required per gripper, the rest can be passive. For each active jaw, a FMS-A1 control unit and a FMS-A connection cable are required.

Description	ID
Active intermediate jaws	
FMS-ZBA 160	0301840
Passive intermediate jaws	
FMS-ZBP 160	0301841
Electronic Processor	
FMS-A2	0301811
Connection cables	
FMS-AK0200	0301820
FMS-AK0500	0301821
FMS-AK1000	0301822
FMS-AK2000	0301823

## Finger blanks

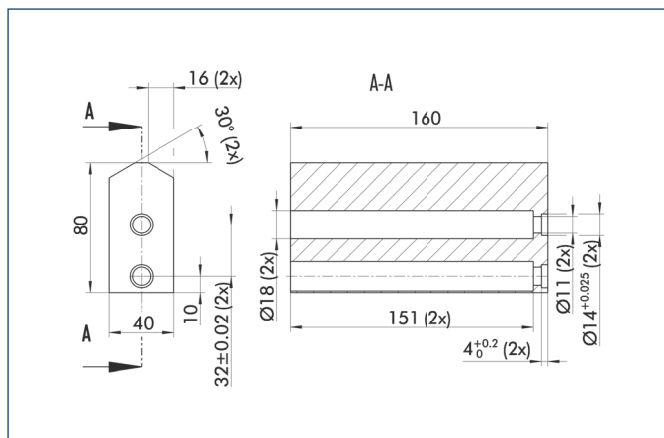

Finger blanks for customized subsequent machining

Description	ID	Material	Scope of delivery
Finger blanks			
ABR-plus 160	0300014	Aluminum	1
SBR-plus 160	0300024	16 MnCr 5	1

You can find more detailed information and individual parts of the above-mentioned accessories in the "Accessories" catalog section.

## Tolerance compensation unit

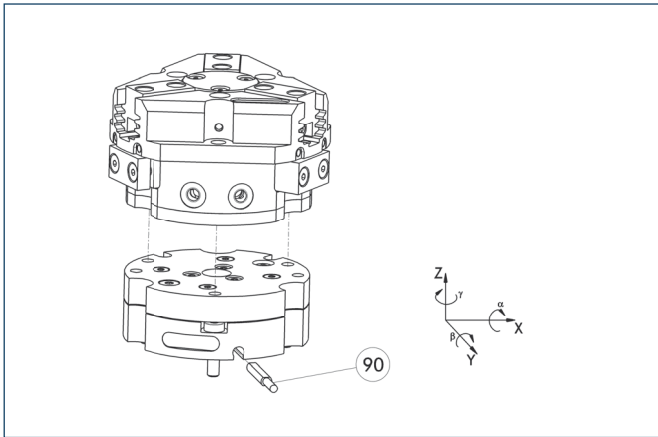

90 Monitoring of locking

Grippers can be directly mounted without an adapter plate. Tolerance compensation unit and gripper have an identical screw connection diagram. Therefore the tolerance compensation units can be assembled later. Please consider the additional assembly height of the tolerance compensation unit. For details see catalog "Robot Accessories".

Description	ID	Locking	Deflection
<b>Compensation unit</b>			
TCU-160-3-MV-Z	0324838	Yes	
TCU-160-3-OV-Z	0324839	No	

## Programmable magnetic switch

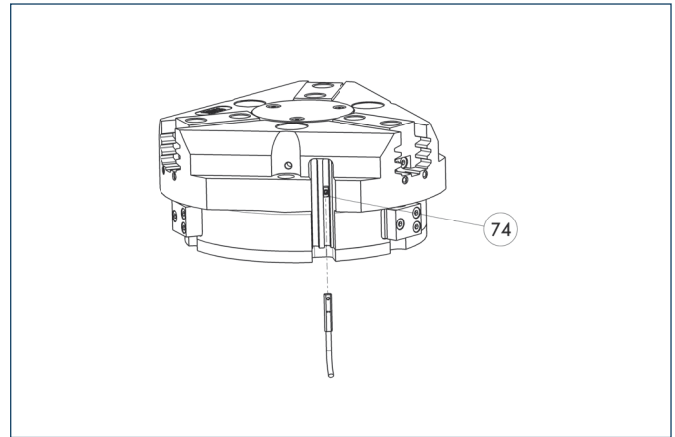

74 Stop for MMS-P

Position monitoring with two programmable positions per sensor. The end position monitoring is mounted in the C-slot.

Description	ID	Recommended product
<b>Programmable magnetic switch</b>		
MMS-P 22-S-M8-PNP	0301370	•
MMSK-P 22-S-PNP	0301371	
<b>Connection cables</b>		
KA BG08-L 4P-0500	0307767	
KA BG08-L 4P-1000	0307768	
KA BW08-L 4P-0500	0307765	
KA BW08-L 4P-1000	0307766	
<b>Sensor Distributor</b>		
V2-M8-4P-2XM8-3P	0301380	

- ① Please note the minimum permitted bending radii for the sensor cables, which are generally 35 mm.
- ① Per gripper one sensor (closer/NO) is required, optionally a cable extension.



## Electronic magnetic switches

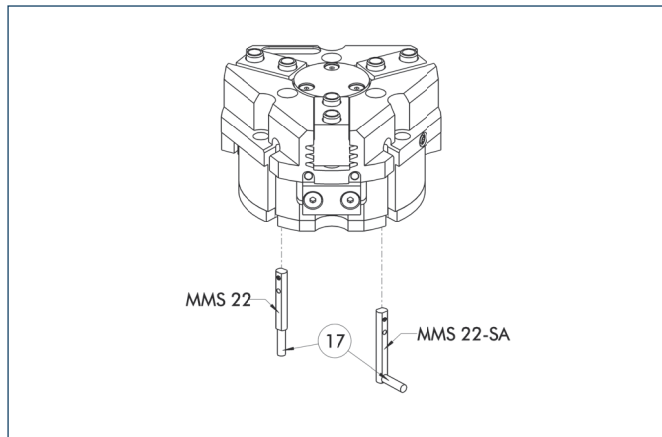

17 Cable outlet

End position monitoring for mounting in the C-slot

Description	ID	Recommended product
<b>Electronic magnetic switches</b>		
MMS 22-S-M5-PNP	0301438	
MMS 22-S-M5-NPN	0301439	
MMS 22-S-M8-PNP	0301432	•
MMS 22-S-M8-NPN	0301433	
MMSK 22-S-PNP	0301434	
MMSK 22-S-NPN	0301435	
<b>Electronic magnetic switches with lateral cable outlet</b>		
MMS 22-S-M5-PNP-SA	0301448	
MMS 22-S-M5-NPN-SA	0301449	
MMS 22-S-M8-PNP-SA	0301442	•
MMS 22-S-M8-NPN-SA	0301443	
MMSK 22-S-PNP-SA	0301444	
MMSK 22-S-NPN-SA	0301445	
<b>Reed Switches</b>		
RMS 22-S-M8	0377720	•
<b>Connection cables</b>		
KA BG05-L 3P-0300	0301652	
KA BG08-L 3P-0300-PNP	0301622	
KA BG08-L 3P-0500-PNP	0301623	
KA BW05-L 3P-0300	0301650	
KA BW08-L 3P-0300-NPN	0301602	
KA BW08-L 3P-0300-PNP	0301594	
KA BW08-L 3P-0500-NPN	9641116	
KA BW08-L 3P-0500-PNP	0301502	
<b>Cable extensions</b>		
KV BW08-SG08 3P-0030-PNP	0301495	
KV BW08-SG08 3P-0100-PNP	0301496	
KV BW08-SG08 3P-0200-PNP	0301497	

① Two sensors (closer/NO) are required for each gripper, plus extension cables as an option.

① Please note the minimum permitted bending radii for the sensor cables, which are generally 35 mm.

## Inductive proximity switches

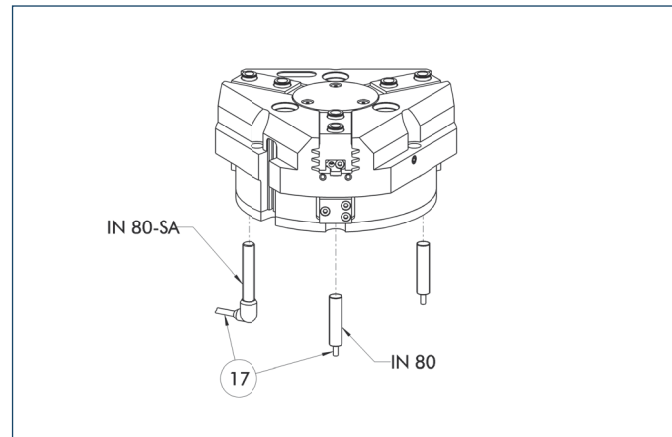

17 Cable outlet

End position monitoring for direct mounting

Description	ID	Recommended product
<b>Inductive proximity switches</b>		
IN 80-S-M8	0301478	•
IN 80-S-M12	0301578	
INK 80-S	0301550	
<b>Inductive proximity switch with lateral outlet</b>		
IN 80-S-M12-SA	0301587	
IN 80-S-M8-SA	0301483	•
INK 80-S-SA	0301566	
<b>Connection cables</b>		
KA BG08-L 3P-0300-PNP	0301622	
KA BG08-L 3P-0500-PNP	0301623	
KA BG12-L 3P-0500-PNP	30016369	
KA BW08-L 3P-0300-PNP	0301594	
KA BW08-L 3P-0500-PNP	0301502	
KA BW12-L 3P-0300-PNP	0301503	
KA BW12-L 3P-0500-PNP	0301507	
<b>Cable extensions</b>		
KV BG12-SG12 3P-0030-PNP	0301999	
KV BG12-SG12 3P-0060-PNP	0301998	
KV BW08-SG08 3P-0030-PNP	0301495	
KV BW08-SG08 3P-0100-PNP	0301496	
KV BW08-SG08 3P-0200-PNP	0301497	
KV BW12-SG12 3P-0030-PNP	0301595	
KV BW12-SG12 3P-0100-PNP	0301596	
KV BW12-SG12 3P-0200-PNP	0301597	

① Two sensors (closer/NO) are required for each gripper, plus extension cables as an option.

① Please note the minimum permitted bending radii for the sensor cables, which are generally 35 mm.

## Cylindrical Reed Switches

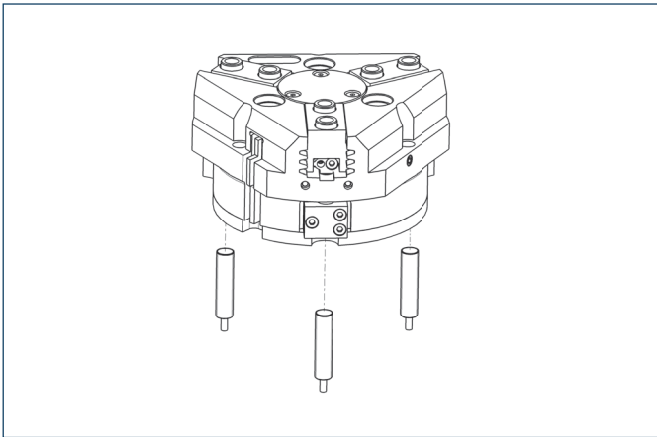

End position monitoring mounted with mounting kit

Description	ID
Mounting kit for proximity switch	
AS-RMS 80 PGN/PZN-plus 160-380	<b>0377727</b>
Reed Switches	
RMS 80-S-M8	<b>0377721</b>

- ① Two sensors (closer/NO) are required for each gripper, plus extension cables as an option.
- ① This mounting kit needs to be ordered optionally as an accessory.
- ① Please note the minimum permitted bending radii for the sensor cables, which are generally 35 mm.

## Analog position sensor

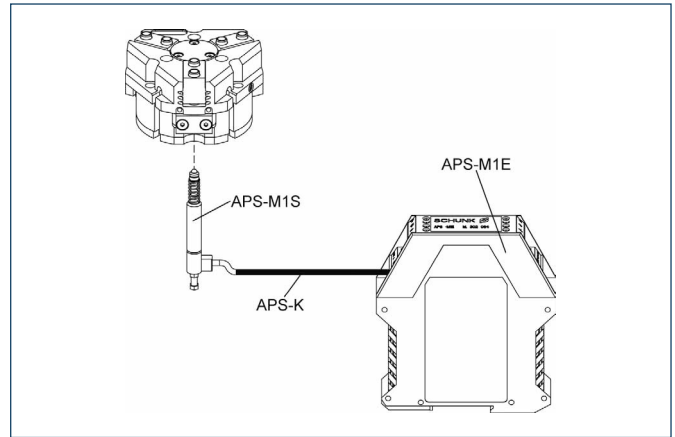

Analog multi position monitoring for any desired positions

Description	ID
Mounting kit	
AS-APS-M1-160/1 and 240/2	<b>0302083</b>
AS-APS-M1-160/2	<b>0302084</b>
Connection cables	
APS-K0200	<b>0302066</b>
APS-K0700	<b>0302068</b>
Electronic Processor	
APS-M1E	<b>0302064</b>
Sensor	
APS-M1S	<b>0302062</b>

- ① When using an APS system, for each gripper a mounting kit (AS-APS), an APS sensor (APS-M1S, incl. 3 m cable) as well as an electronics (APS-M1e) are required.
- ① An extension cable (APS-K) can be connected between the sensor and the electronics as an option. The max. cable length between the sensor and the electronics is 10 m, between the electronics and their control unit (PLC) it is max. 1 m.



You can find more detailed information and individual parts of the above-mentioned accessories in the "Accessories" catalog section.

## Flexible Position Sensor

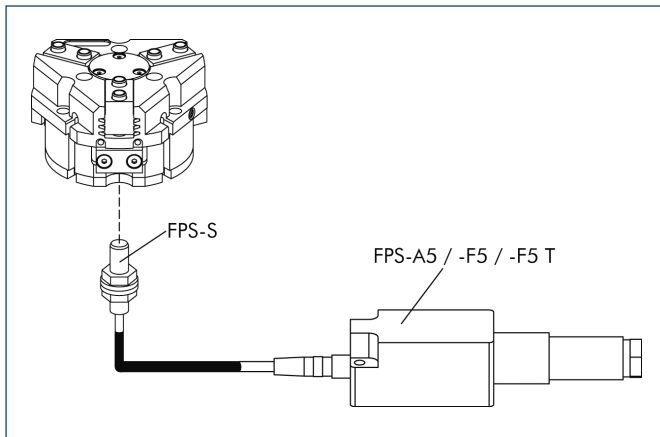

Flexible position monitoring of up to five positions

Description	ID
<b>Mounting kit for FPS</b>	
AS-PGN/PZN-plus 160/1	0301638
AS-PGN/PZN-plus 160/2	0301639
<b>Electronic Processor</b>	
FPS-F5	0301805
FPS-F5 T	0301807
<b>Sensor</b>	
FPS-S M8	0301704

① When using a FPS system, a FPS sensor (FPS-S) and a control unit (FPS-F5 / F5 T or A5) are required for each gripper as well as a mounting kit (AS), if listed. Cable extensions (KV) are available as options in the "Accessories" catalog section.

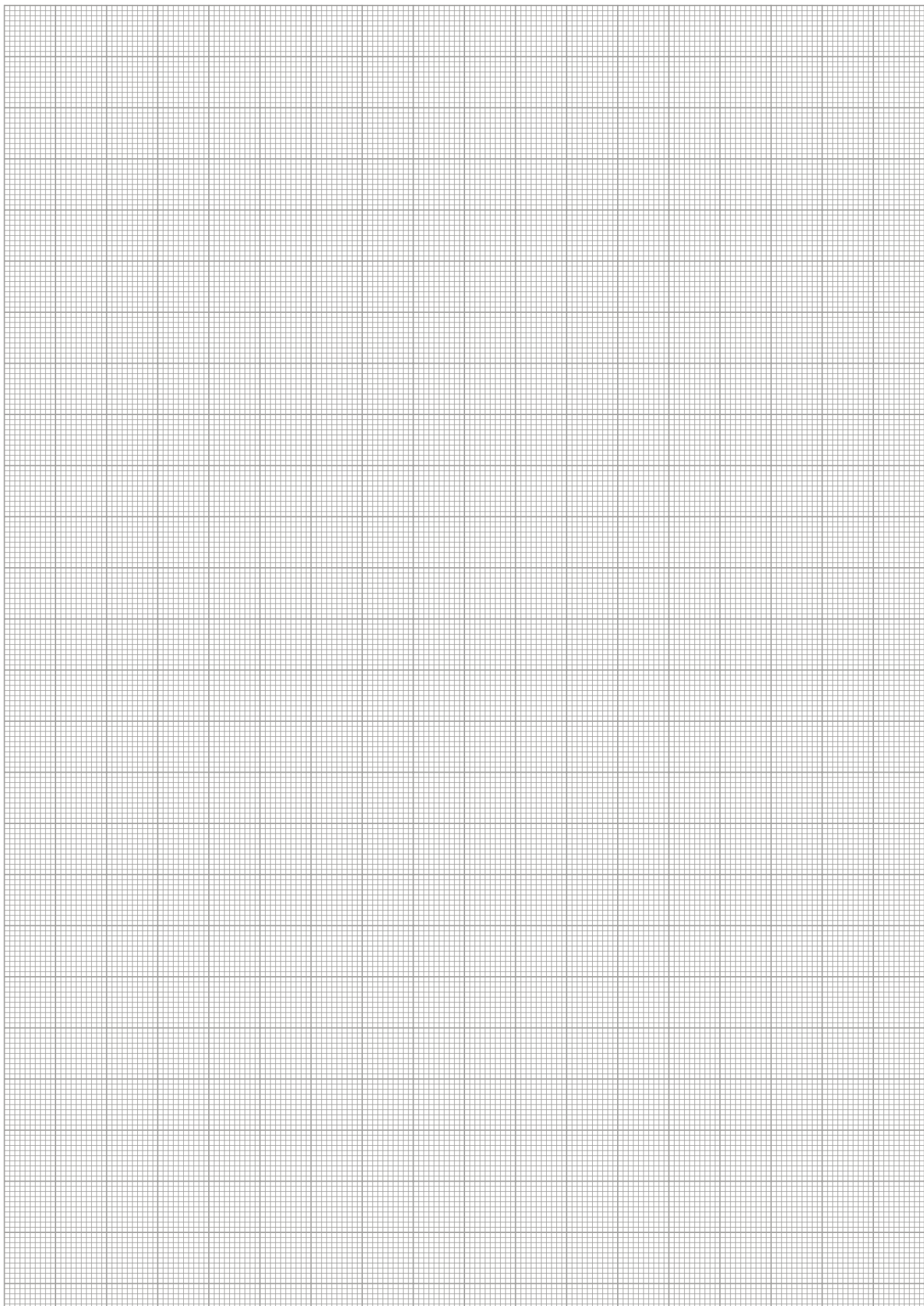

# PZN-plus 200

Pneumatic • 3-Finger Centric Gripper • Universal Gripper



## Gripping force, I.D. gripping

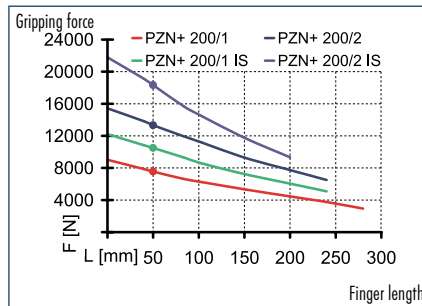

## Gripping force, O.D. gripping

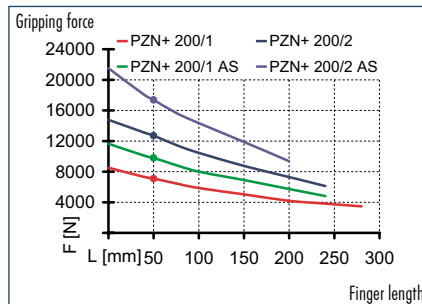

## Finger load

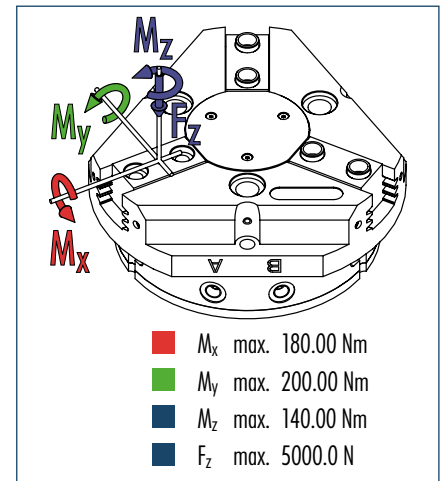

① The indicated moments and forces are static values, apply per base jaw and may occur simultaneously.  $M_y$  may arise in addition to the moment generated by the gripping force itself. If the max. permitted finger weight is exceeded, it is imperative to throttle the air pressure so that the jaw movement occurs without any hitting or bouncing. Service life may be reduced.

## Technical data

Description	PZN-plus 200-1	PZN-plus 200-2	PZN-plus 200-1-AS	PZN-plus 200-2-AS	PZN-plus 200-1-IS	PZN-plus 200-2-IS
ID	0303315	0303415	0303515	0303615	0303545	0303645
Stroke per finger [mm]	25	14	25	14	25	14
Closing force [N]	7100	12700	9800	17380		
Opening force [N]	7540	13330			10500	18330
Min. spring force [N]			2700	4680	2960	5000
Weight [kg]	11	11	15.7	15.7	15.7	15.7
Recommended workpiece weight [kg]	35.5	63.5	35.5	63.5	35.5	63.5
Air consumption per double stroke [cm <sup>3</sup> ]	1040	1040	1725	1725	1725	1725
Min./max. operating pressure [bar]	2/8	2/8	4/6.5	4/6.5	4/6.5	4/6.5
Nominal operating pressure [bar]	6	6	6	6	6	6
Closing/opening time [s]	1.2/1.2	1.2/1.2	1/1.5	1/1.5	1.5/1	1.5/1
Max. permitted finger length [mm]	280	240	240	200	240	200
Max. permitted weight per finger [kg]	6.5	6.5	6.5	6.5	6.5	6.5
IP class	40	40	40	40	40	40
Min./max. ambient temperature [°C]	-10/90	-10/90	-10/90	-10/90	-10/90	-10/90
Repeat accuracy [mm]	0.05	0.05	0.05	0.05	0.05	0.05
Cleanroom class						
ISO-classification 14644-1	5	5	5	5	5	5

## OPTIONS and their characteristics

Description	37303315	37303415	37303515	37303615	37303545	37303645
Dust-protection version	37303315	37303415	37303515	37303615	37303545	37303645
IP class	64	64	64	64	64	64
Weight [kg]	12	12	16.7	16.7	16.7	16.7
Anti-corrosion version	38303315	38303415	38303515	38303615	38303545	38303645
High-temperature version	39303315	39303415	39303515	39303615	39303545	39303645
Min./max. ambient temperature [°C]	-10/130	-10/130	-10/130	-10/130	-10/130	-10/130
Precision version	0303345	0303445	0303495	0303595		

### Main view

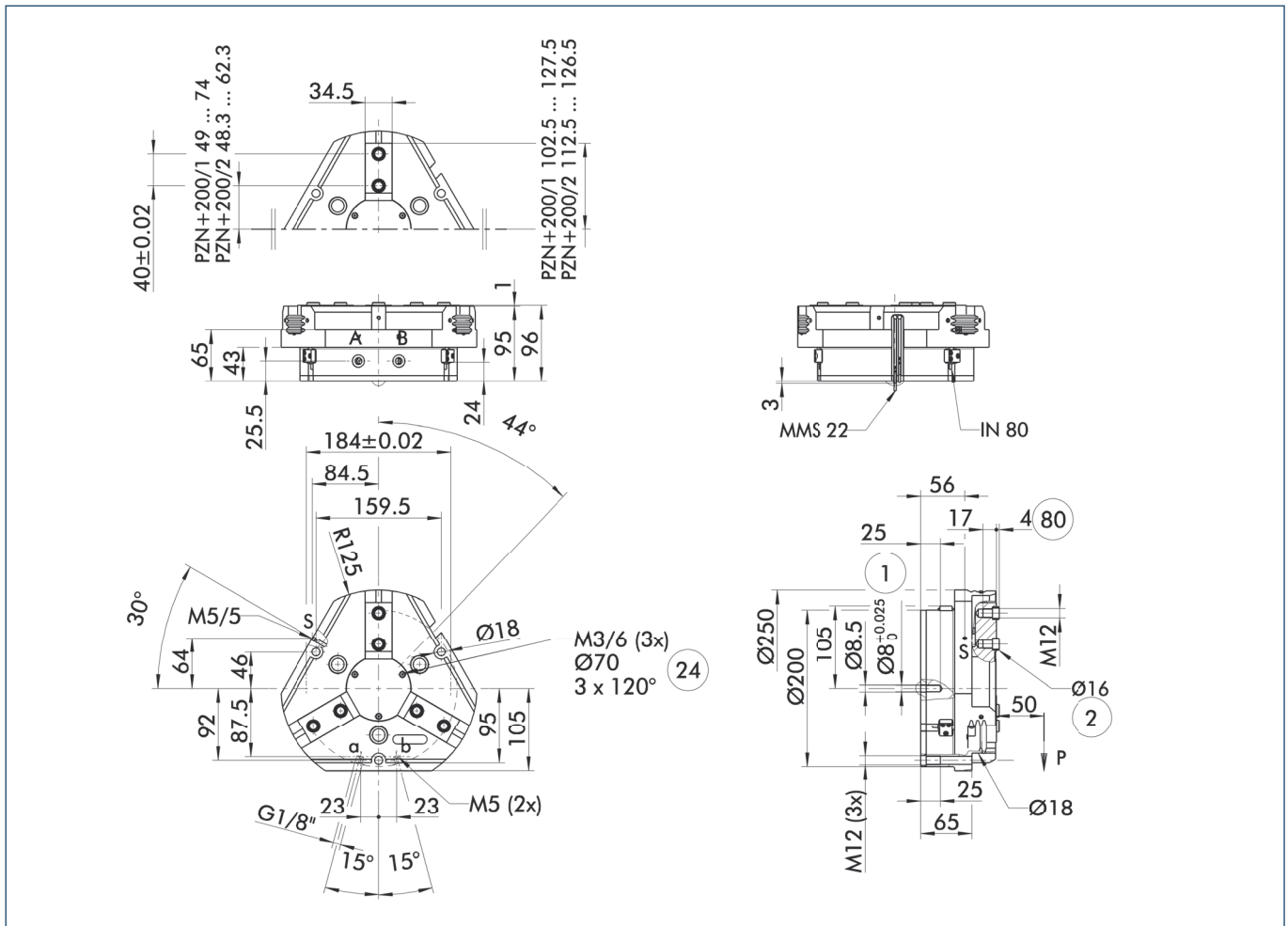

The drawing shows the gripper in the basic version with closed jaws, the dimensions do not include the options described below.

① The SDV-P pressure maintenance valve can also be used for I.D. or O.D. gripping alternatively or in addition to the spring-loaded, mechanical gripping force maintenance device (see "Accessories" catalog section).

- A, a Main/direct connection, gripper opening
- B, b Main/direct connection, gripper closing
- S Air purge connection
- ① Gripper connection
- ② Finger connection
- ②④ Bolt circle
- ⑧⑩ Depth of the centering sleeve hole in the matching part

### Hose-free direct connection

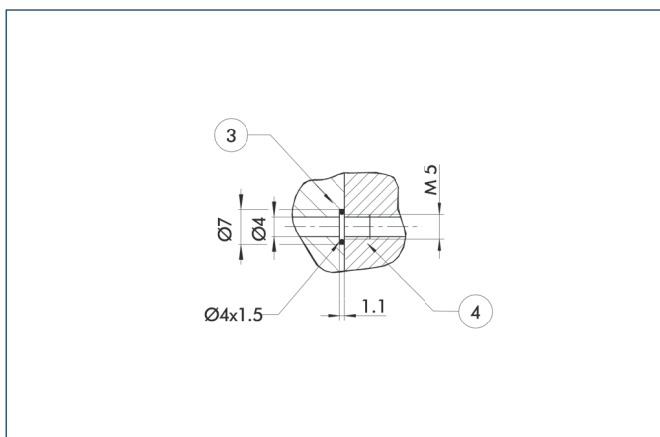

- ③ Adapter
- ④ Gripper

The direct connection is used for supplying compressed air without hoses. Instead, the pressure medium is fed through bore-holes in the mounting plate.

### AS/IS gripping force maintenance device

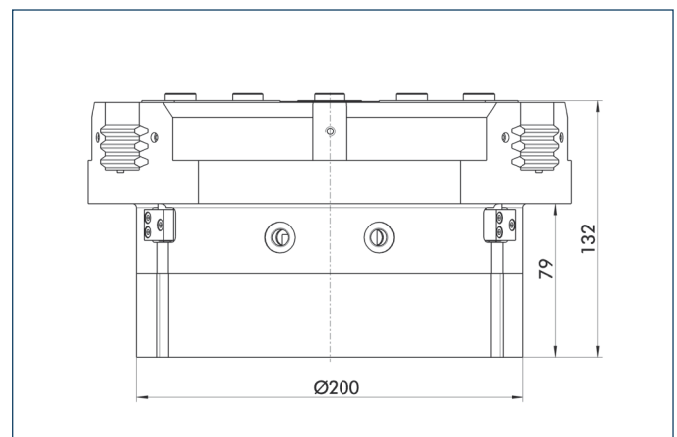

The mechanical gripping force maintenance device ensures a minimum gripping force even in case of pressure drop. This acts as closing force in the AS version, and as opening force in the IS version. In addition, the gripping force maintenance device can also be used for increasing the gripping force or for single-acting gripping.

# PZN-plus 200

Pneumatic • 3-Finger Centric Gripper • Universal Gripper

## Dust-protection version

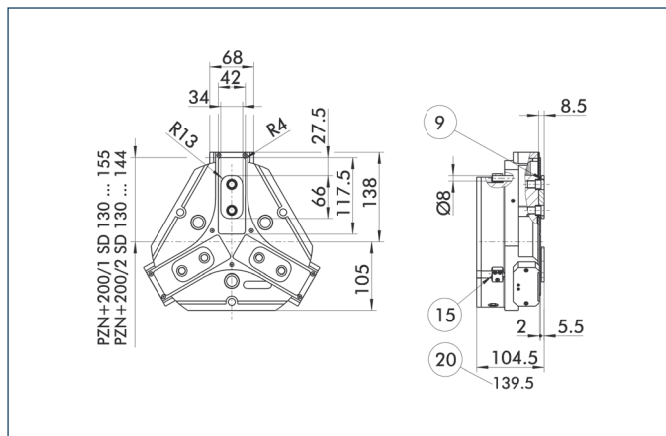

- ⑨ For mounting screw connection diagram, see basic version  
 ⑮ Sealing bolt  
 ⑳ For AS / IS version

The “dust-protection” option increases the degree of protection against penetrating substances. The screw connection diagram shifts by the height of the intermediate jaw. The finger length is still measured from the upper edge of the gripper housing.

## Precision version

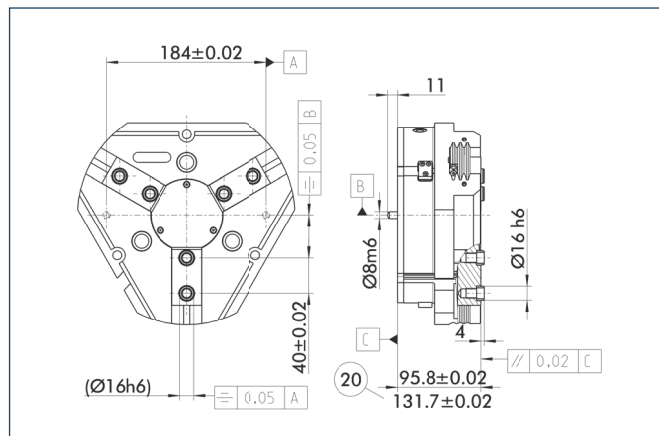

- ⑳ For AS / IS version

The indicated tolerances just refer to the types of precision versions shown in the chart of technical specifications. All other types of precision versions are available on request.

## Spring-loaded pressure piece

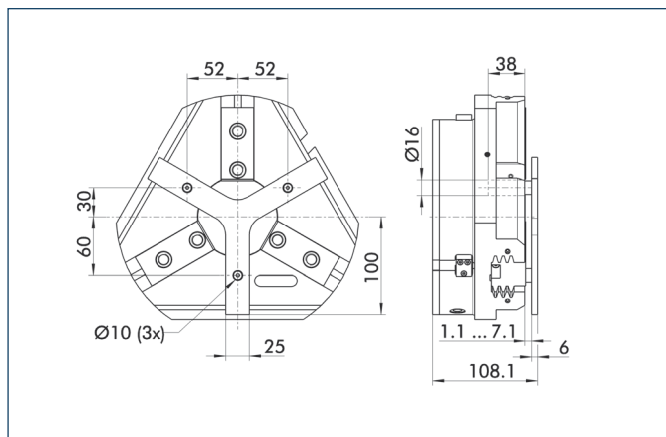

For spring-supported positioning of the workpiece against a stop after the gripper has opened. Especially developed for loading machines.

Description	ID	Stroke	Min. force
Spring-loaded pressure piece			
A-PZN-plus/DPZ-plus 200	0303725	6 mm	247 N

- ① The pressure piece cannot be combined with the dust-protection version. Please contact us if you require a special pressure piece.

## Universal intermediate jaw

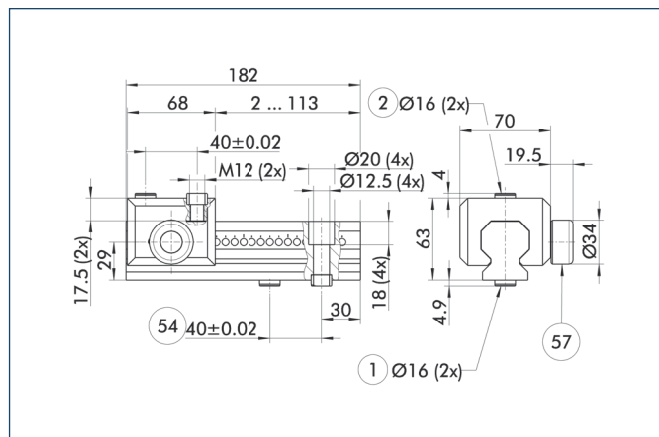

- ① Gripper connection  
 ② Finger connection  
 ⑤④ Optional right or left connection  
 ⑤⑦ Locking

The universal intermediate jaw allows fast tool-free and reliable plugging and shifting of top jaws at the gripper.

Description	ID	Grid dimension
Universal intermediate jaw		
UZB 200	0300047	7 mm
UZB-S 200	5518275	7 mm

- ① The slide UZB-S can be removed completely and has to be ordered separately. Moreover, it allows a fast jaw change.

### Force measuring jaws

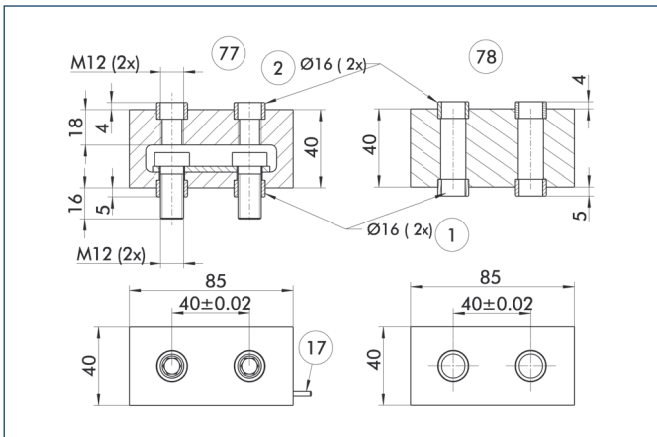

- ① Gripper connection
- ② Finger connection
- ⑦ Active intermediate jaws
- ⑧ Passive intermediate jaws
- ⑰ Cable outlet

Force measuring jaws measure gripping forces, but can also determine workpiece weights or dimensional deviations. There are active and passive intermediate jaws (FMS-ZBA or FMS-ZBP). At least one active force measuring jaw is required per gripper, the rest can be passive. For each active jaw, a FMS-A1 control unit and a FMS-A connection cable are required.

Description	ID
<b>Active intermediate jaws</b>	
FMS-ZBA 200	0301842
<b>Passive intermediate jaws</b>	
FMS-ZBP 200	0301843
<b>Electronic Processor</b>	
FMS-A2	0301811
<b>Connection cables</b>	
FMS-AK0200	0301820
FMS-AK0500	0301821
FMS-AK1000	0301822
FMS-AK2000	0301823

### Finger blanks

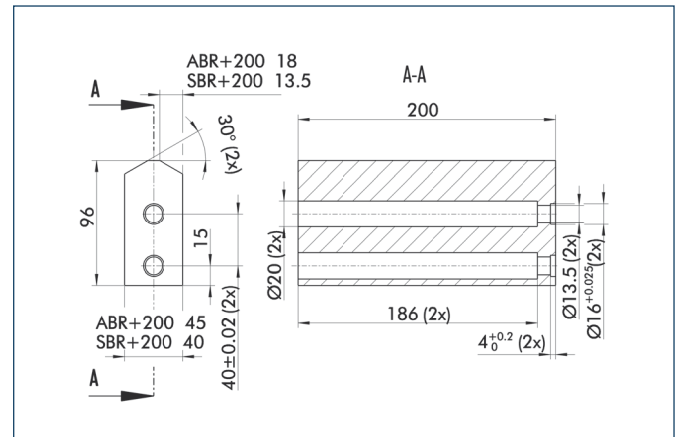

Finger blanks for customized subsequent machining

Description	ID	Material	Scope of delivery
<b>Finger blanks</b>			
ABR-plus 200	0300015	Aluminum	1
SBR-plus 200	0300025	16 MnCr 5	1



## Tolerance compensation unit

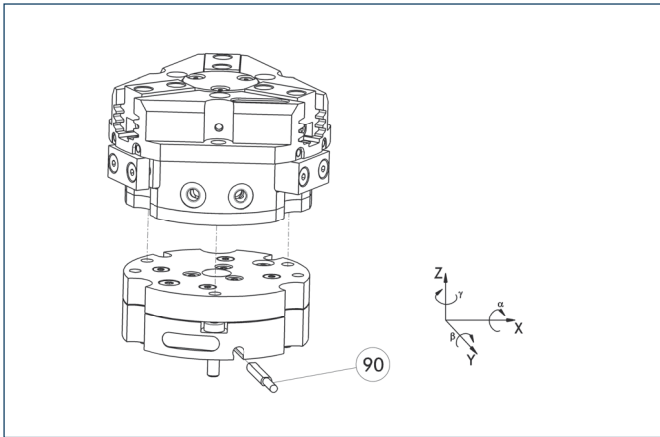

90 Monitoring of locking

Grippers can be directly mounted without an adapter plate. Tolerance compensation unit and gripper have an identical screw connection diagram. Therefore the tolerance compensation units can be assembled later. Please consider the additional assembly height of the tolerance compensation unit. For details see catalog "Robot Accessories".

Description	ID	Locking	Deflection
<b>Compensation unit</b>			
TCU-200-3-MV-Z	0324856	Yes	
TCU-200-3-OV-Z	0324857	No	

## Programmable magnetic switch

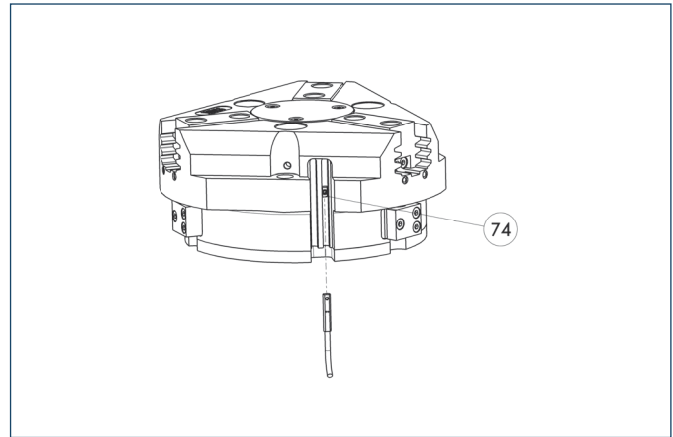

74 Stop for MMS-P

Position monitoring with two programmable positions per sensor. The end position monitoring is mounted in the C-slot.

Description	ID	Recommended product
<b>Programmable magnetic switch</b>		
MMS-P 22-S-M8-PNP	0301370	•
MMSK-P 22-S-PNP	0301371	
<b>Connection cables</b>		
KA BG08-L 4P-0500	0307767	
KA BG08-L 4P-1000	0307768	
KA BW08-L 4P-0500	0307765	
KA BW08-L 4P-1000	0307766	
<b>Sensor Distributor</b>		
V2-M8-4P-2XM8-3P	0301380	

- ① Please note the minimum permitted bending radii for the sensor cables, which are generally 35 mm.
- ① Per gripper one sensor (closer/NO) is required, optionally a cable extension.

### Electronic magnetic switches

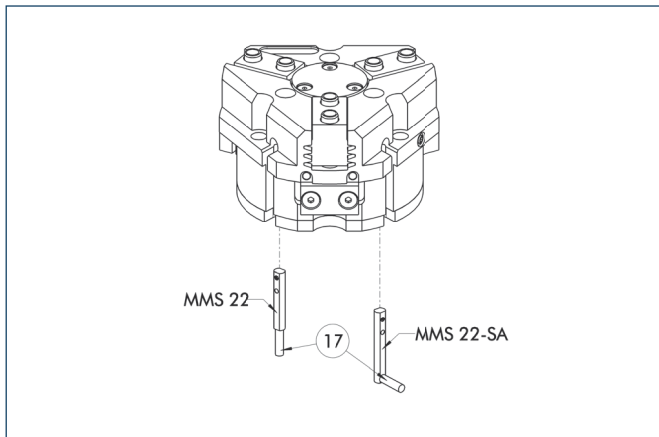

⑰ Cable outlet

End position monitoring for mounting in the C-slot

Description	ID	Recommended product
<b>Electronic magnetic switches</b>		
MMS 22-S-M5-PNP	0301438	
MMS 22-S-M5-NPN	0301439	
MMS 22-S-M8-PNP	0301432	•
MMS 22-S-M8-NPN	0301433	
MMSK 22-S-PNP	0301434	
MMSK 22-S-NPN	0301435	
<b>Electronic magnetic switches with lateral cable outlet</b>		
MMS 22-S-M5-PNP-SA	0301448	
MMS 22-S-M5-NPN-SA	0301449	
MMS 22-S-M8-PNP-SA	0301442	•
MMS 22-S-M8-NPN-SA	0301443	
MMSK 22-S-PNP-SA	0301444	
MMSK 22-S-NPN-SA	0301445	
<b>Reed Switches</b>		
RMS 22-S-M8	0377720	•
<b>Connection cables</b>		
KA BG05-L 3P-0300	0301652	
KA BG08-L 3P-0300-PNP	0301622	
KA BG08-L 3P-0500-PNP	0301623	
KA BW05-L 3P-0300	0301650	
KA BW08-L 3P-0300-NPN	0301602	
KA BW08-L 3P-0300-PNP	0301594	
KA BW08-L 3P-0500-NPN	9641116	
KA BW08-L 3P-0500-PNP	0301502	
<b>Cable extensions</b>		
KV BW08-SG08 3P-0030-PNP	0301495	
KV BW08-SG08 3P-0100-PNP	0301496	
KV BW08-SG08 3P-0200-PNP	0301497	

① Two sensors (closer/NO) are required for each gripper, plus extension cables as an option.

① Please note the minimum permitted bending radii for the sensor cables, which are generally 35 mm.

### Inductive proximity switches

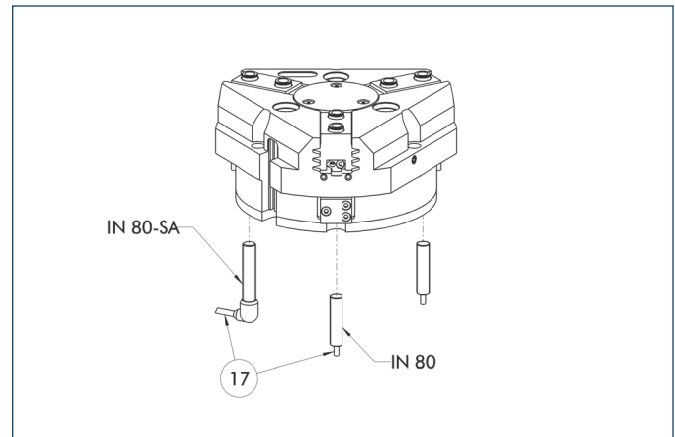

⑰ Cable outlet

End position monitoring for direct mounting

Description	ID	Recommended product
<b>Inductive proximity switches</b>		
IN 80-S-M8	0301478	•
IN 80-S-M12	0301578	
INK 80-S	0301550	
<b>Inductive proximity switch with lateral outlet</b>		
IN 80-S-M12-SA	0301587	
IN 80-S-M8-SA	0301483	•
INK 80-S-SA	0301566	
<b>Connection cables</b>		
KA BG08-L 3P-0300-PNP	0301622	
KA BG08-L 3P-0500-PNP	0301623	
KA BG12-L 3P-0500-PNP	30016369	
KA BW08-L 3P-0300-PNP	0301594	
KA BW08-L 3P-0500-PNP	0301502	
KA BW12-L 3P-0300-PNP	0301503	
KA BW12-L 3P-0500-PNP	0301507	
<b>Cable extensions</b>		
KV BG12-SG12 3P-0030-PNP	0301999	
KV BG12-SG12 3P-0060-PNP	0301998	
KV BW08-SG08 3P-0030-PNP	0301495	
KV BW08-SG08 3P-0100-PNP	0301496	
KV BW08-SG08 3P-0200-PNP	0301497	
KV BW12-SG12 3P-0030-PNP	0301595	
KV BW12-SG12 3P-0100-PNP	0301596	
KV BW12-SG12 3P-0200-PNP	0301597	

① Two sensors (closer/NO) are required for each gripper, plus extension cables as an option.

① Please note the minimum permitted bending radii for the sensor cables, which are generally 35 mm.



You can find more detailed information and individual parts of the above-mentioned accessories in the "Accessories" catalog section.

## Cylindrical Reed Switches

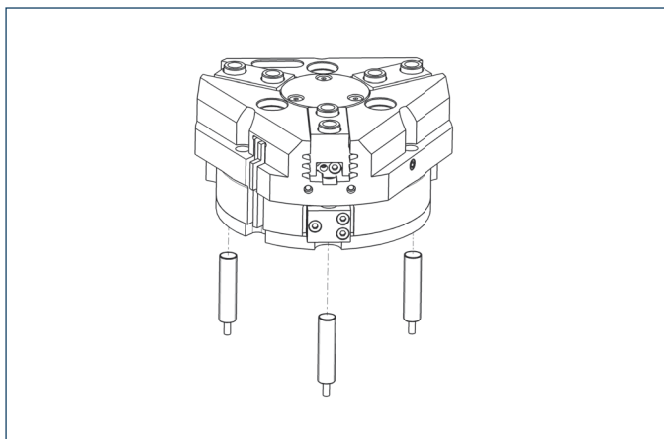

End position monitoring mounted with mounting kit

Description	ID
Mounting kit for proximity switch	
AS-RMS 80 PGN/PZN-plus 160-380	<b>0377727</b>
Reed Switches	
RMS 80-S-M8	<b>0377721</b>

- ① Two sensors (closer/NO) are required for each gripper, plus extension cables as an option.
- ① This mounting kit needs to be ordered optionally as an accessory.
- ① Please note the minimum permitted bending radii for the sensor cables, which are generally 35 mm.

## Analog position sensor

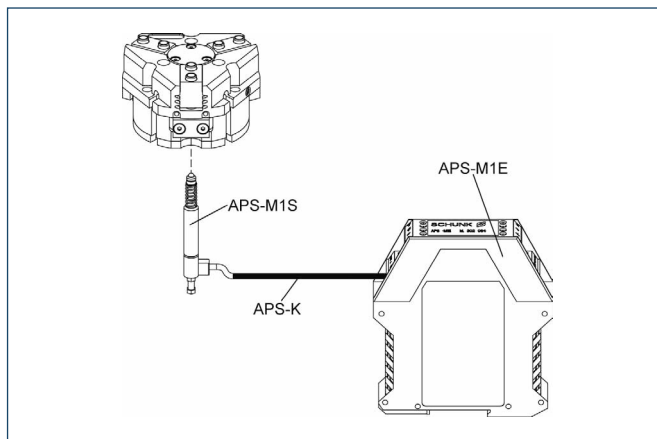

Analog multi position monitoring for any desired positions

Description	ID
Mounting kit	
AS-APS-M1-200/1 and 380/2	<b>0302085</b>
AS-APS-M1-200/2	<b>0302086</b>
Connection cables	
APS-K0200	<b>0302066</b>
APS-K0700	<b>0302068</b>
Electronic Processor	
APS-M1E	<b>0302064</b>
Sensor	
APS-M1S	<b>0302062</b>

- ① When using an APS system, for each gripper a mounting kit (AS-APS), an APS sensor (APS-M 1S, incl. 3 m cable) as well as an electronics (APS-M1e) are required.
- ① An extension cable (APS-K) can be connected between the sensor and the electronics as an option. The max. cable length between the sensor and the electronics is 10 m, between the electronics and their control unit (PLC) it is max. 1 m.

## Flexible Position Sensor

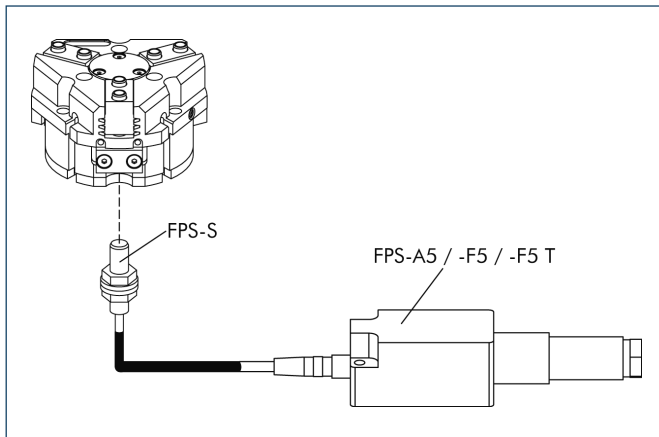

Flexible position monitoring of up to five positions

Description	ID
<b>Mounting kit for FPS</b>	
AS-PGN/PZN-plus 200/1	0301640
AS-PGN/PZN-plus 200/2	0301641
<b>Electronic Processor</b>	
FPS-F5	0301805
FPS-F5 T	0301807
<b>Sensor</b>	
FPS-S M8	0301704

- ① When using a FPS system, a FPS sensor (FPS-S) and a control unit (FPS-F5 / F5 T or A5) are required for each gripper as well as a mounting kit (AS), if listed. Cable extensions (KV) are available as options in the "Accessories" catalog section.



You can find more detailed information and individual parts of the above-mentioned accessories in the "Accessories" catalog section.

# PZN-plus 240

Pneumatic • 3-Finger Centric Gripper • Universal Gripper



## Gripping force, I.D. gripping

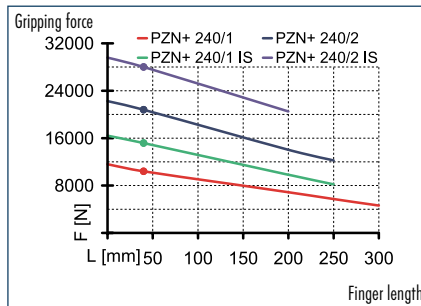

## Gripping force, O.D. gripping

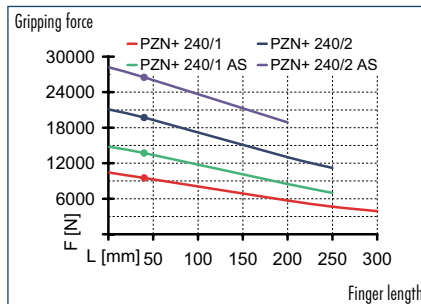

## Finger load

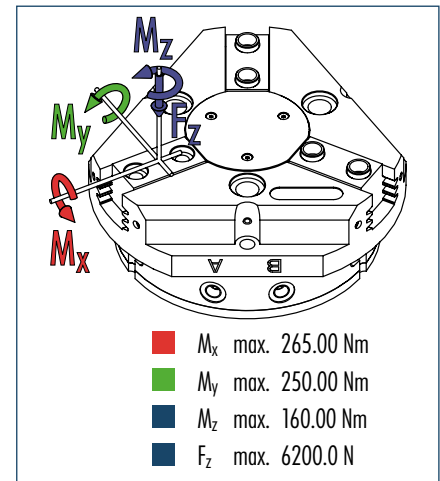

① The indicated moments and forces are static values, apply per base jaw and may occur simultaneously.  $M_y$  may arise in addition to the moment generated by the gripping force itself. If the max. permitted finger weight is exceeded, it is imperative to throttle the air pressure so that the jaw movement occurs without any hitting or bouncing. Service life may be reduced.

## Technical data

Description	PZN-plus 240-1	PZN-plus 240-2	PZN-plus 240-1-AS	PZN-plus 240-2-AS	PZN-plus 240-1-IS	PZN-plus 240-2-IS
ID	0303316	0303416	0303516	0303616	0303546	0303646
Stroke per finger [mm]	30	17	30	17	30	17
Closing force [N]	9500	19700	13720	26500		
Opening force [N]	10400	20800			15170	28000
Min. spring force [N]			4220	6800	4770	7200
Weight [kg]	20	20	24	24	24	24
Recommended workpiece weight [kg]	50	100.5	50	100.5	50	100.5
Air consumption per double stroke [cm <sup>3</sup> ]	1780	1780	3090	3090	3090	3090
Min./max. operating pressure [bar]	2/8	2/8	4/6.5	4/6.5	4/6.5	4/6.5
Nominal operating pressure [bar]	6	6	6	6	6	6
Closing/opening time [s]	1.25/1.25	1.25/1.25	1.1/2.1	1.1/2.1	1.7/1.1	1.7/1.1
Max. permitted finger length [mm]	300	250	250	200	250	200
Max. permitted weight per finger [kg]	8.5	8.5	8.5	8.5	8.5	8.5
IP class	40	40	40	40	40	40
Min./max. ambient temperature [°C]	-10/90	-10/90	-10/90	-10/90	-10/90	-10/90
Repeat accuracy [mm]	0.05	0.05	0.05	0.05	0.05	0.05
Cleanroom class						
ISO-classification 14644-1	5	5	5	5	5	5

## OPTIONS and their characteristics

Option	37303316	37303416	37303516	37303616	37303546	37303646
Dust-protection version	37303316	37303416	37303516	37303616	37303546	37303646
IP class	64	64	64	64	64	64
Weight [kg]	21.5	21.5	25.5	25.5	25.5	25.5
Anti-corrosion version	38303316	38303416	38303516	38303616	38303546	38303646
High-temperature version	39303316	39303416	39303516	39303616	39303546	39303646
Min./max. ambient temperature [°C]	-10/130	-10/130	-10/130	-10/130	-10/130	-10/130
Precision version	0303346	0303446	0303496	0303596		

## Main view

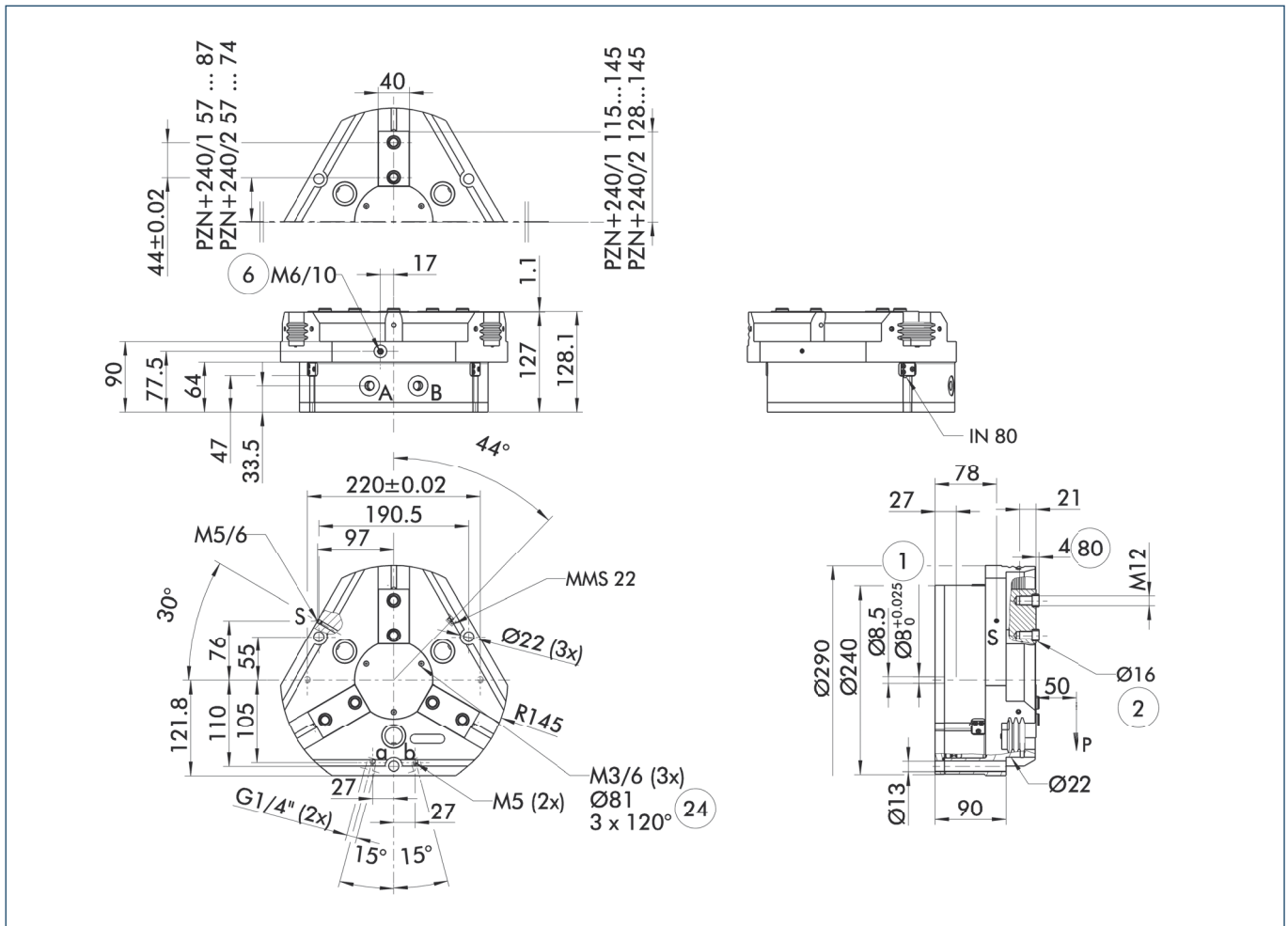

The drawing shows the gripper in the basic version with closed jaws, the dimensions do not include the options described below.

① The SDV-P pressure maintenance valve can also be used for I.D. or O.D. gripping alternatively or in addition to the spring-loaded, mechanical gripping force maintenance device (see "Accessories" catalog section).

A, a Main/direct connection, gripper opening  
 B, b Main/direct connection, gripper closing  
 S Air purge connection  
 ① Gripper connection  
 ② Finger connection

⑥ Lubricating nipple connection  
 ②④ Bolt circle  
 ⑧⑩ Depth of the centering sleeve hole in the matching part

## Hose-free direct connection

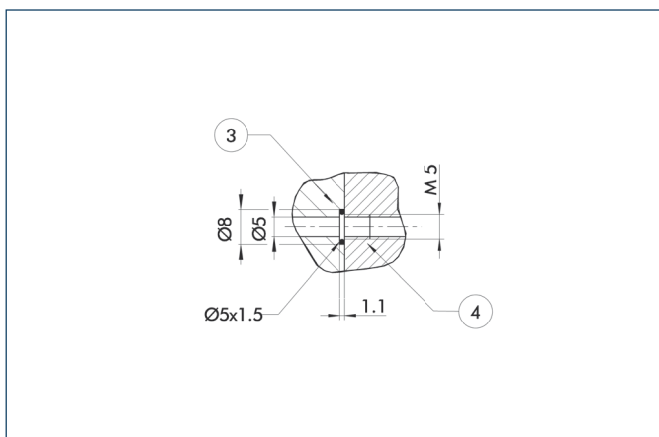

③ Adapter  
 ④ Gripper

The direct connection is used for supplying compressed air without hoses. Instead, the pressure medium is fed through bore-holes in the mounting plate.

## AS/IS gripping force maintenance device

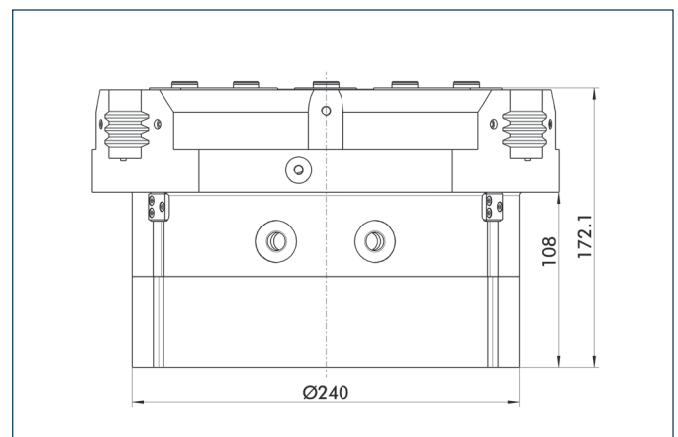

The mechanical gripping force maintenance device ensures a minimum gripping force even in case of pressure drop. This acts as closing force in the AS version, and as opening force in the IS version. In addition, the gripping force maintenance device can also be used for increasing the gripping force or for single-acting gripping.

# PZN-plus 240

Pneumatic • 3-Finger Centric Gripper • Universal Gripper

## Dust-protection version

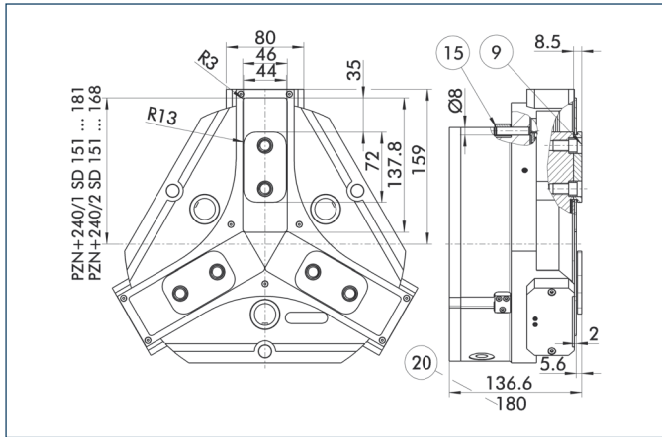

- ⑨ For mounting screw connection diagram, see basic version
- ⑮ Sealing bolt
- ⑳ For AS / IS version

The "dust-protection" option increases the degree of protection against penetrating substances. The screw connection diagram shifts by the height of the intermediate jaw. The finger length is still measured from the upper edge of the gripper housing.

## Precision version

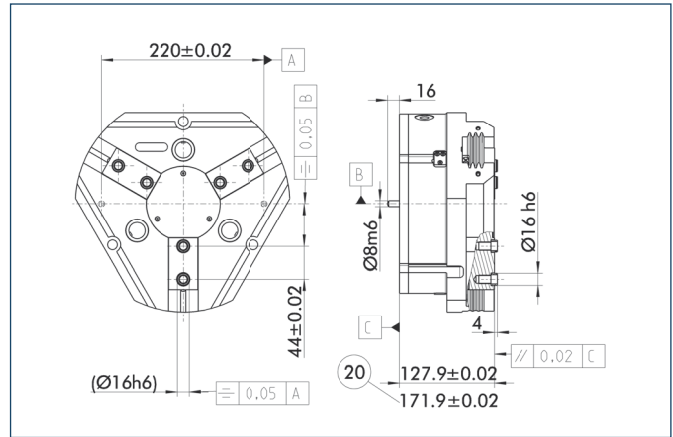

- ⑳ For AS / IS version

The indicated tolerances just refer to the types of precision versions shown in the chart of technical specifications. All other types of precision versions are available on request.

## Spring-loaded pressure piece

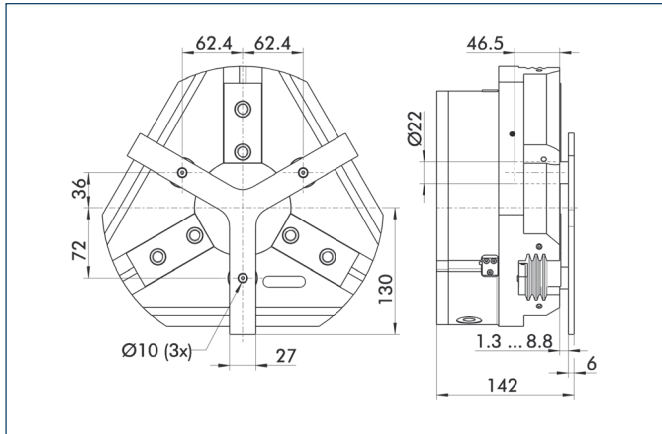

For spring-supported positioning of the workpiece against a stop after the gripper has opened. Especially developed for loading machines.

Description	ID	Stroke	Min. force
Spring-loaded pressure piece			
A-PZN-plus/DPZ-plus 240	0303726	7.5 mm	240 N

- ① The pressure piece cannot be combined with the dust-protection version. Please contact us if you require a special pressure piece.

## Force measuring jaws

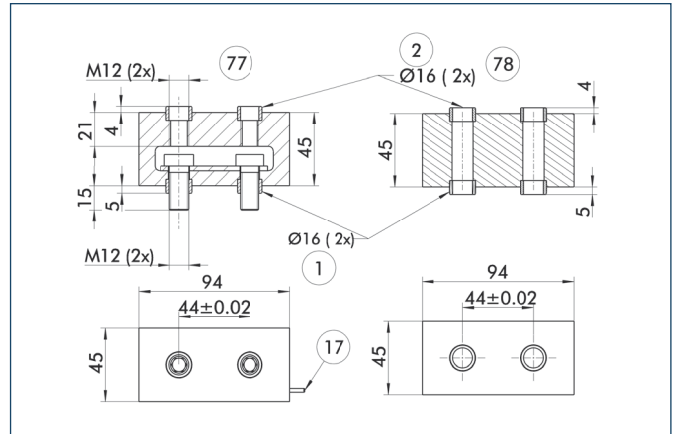

- ① Gripper connection
- ② Finger connection
- ⑰ Cable outlet
- ⑦⑦ Active intermediate jaws
- ⑦⑧ Passive intermediate jaws

Force measuring jaws measure gripping forces, but can also determine workpiece weights or dimensional deviations. There are active and passive intermediate jaws (FMS-ZBA or FMS-ZBP). At least one active force measuring jaw is required per gripper, the rest can be passive. For each active jaw, a FMS-A1 control unit and a FMS-A connection cable are required.

Description	ID
Active intermediate jaws	
FMS-ZBA 240	0301844
Passive intermediate jaws	
FMS-ZBP 240	0301845
Electronic Processor	
FMS-A2	0301811
Connection cables	
FMS-AK0200	0301820
FMS-AK0500	0301821
FMS-AK1000	0301822
FMS-AK2000	0301823

You can find more detailed information and individual parts of the above-mentioned accessories in the "Accessories" catalog section.

## Finger blanks

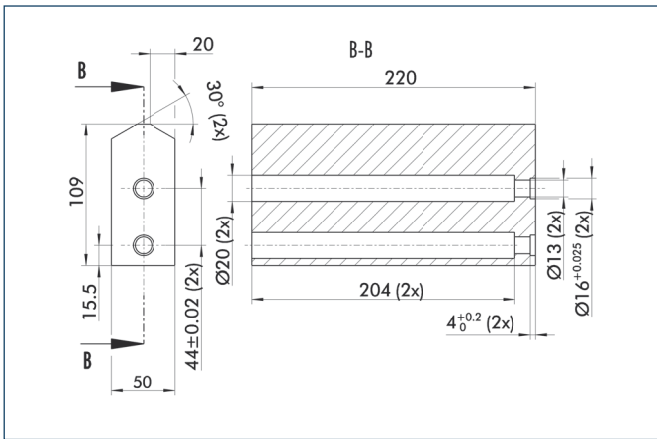

Finger blanks for customized subsequent machining

Description	ID	Material	Scope of delivery
Finger blanks			
ABR-plus 240	0300017	Aluminum	1
SBR-plus 240	0300027	16 MnCr 5	1

## Programmable magnetic switch

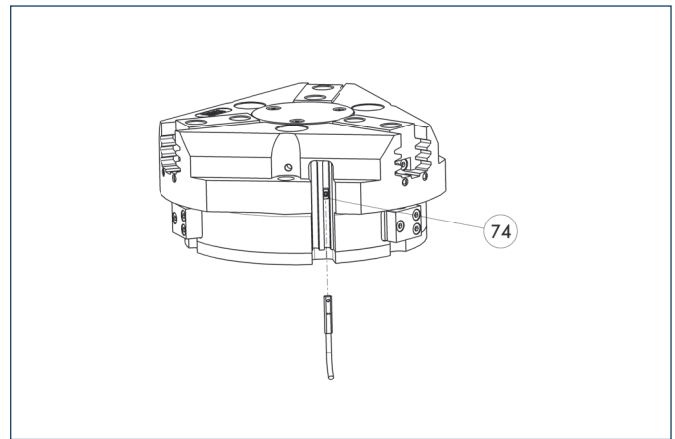

74 Stop for MMS-P

Position monitoring with two programmable positions per sensor. The end position monitoring is mounted in the C-slot.

Description	ID	Recommended product
Programmable magnetic switch		
MMS-P 22-S-M8-PNP	0301370	•
MMSK-P 22-S-PNP	0301371	
Connection cables		
KA BG08-L 4P-0500	0307767	
KA BG08-L 4P-1000	0307768	
KA BW08-L 4P-0500	0307765	
KA BW08-L 4P-1000	0307766	
Sensor Distributor		
V2-M8-4P-2XM8-3P	0301380	

- ① Please note the minimum permitted bending radii for the sensor cables, which are generally 35 mm.
- ① Per gripper one sensor (closer/NO) is required, optionally a cable extension.



You can find more detailed information and individual parts of the above-mentioned accessories in the "Accessories" catalog section.



### Electronic magnetic switches

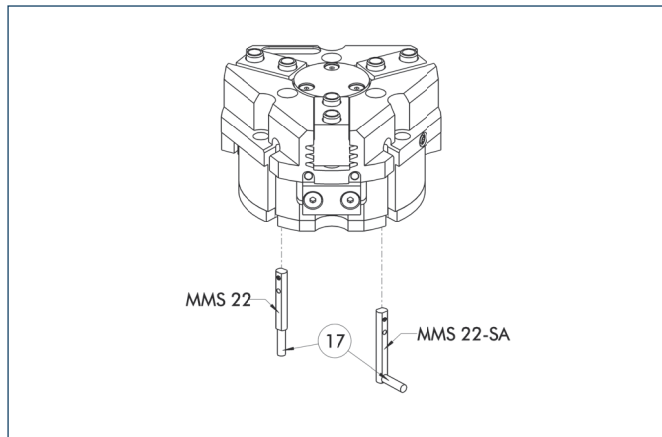

⑰ Cable outlet

End position monitoring for mounting in the C-slot

Description	ID	Recommended product
<b>Electronic magnetic switches</b>		
MMS 22-S-M5-PNP	0301438	
MMS 22-S-M5-NPN	0301439	
MMS 22-S-M8-PNP	0301432	•
MMS 22-S-M8-NPN	0301433	
MMSK 22-S-PNP	0301434	
MMSK 22-S-NPN	0301435	
<b>Electronic magnetic switches with lateral cable outlet</b>		
MMS 22-S-M5-PNP-SA	0301448	
MMS 22-S-M5-NPN-SA	0301449	
MMS 22-S-M8-PNP-SA	0301442	•
MMS 22-S-M8-NPN-SA	0301443	
MMSK 22-S-PNP-SA	0301444	
MMSK 22-S-NPN-SA	0301445	
<b>Reed Switches</b>		
RMS 22-S-M8	0377720	•
<b>Connection cables</b>		
KA BG05-L 3P-0300	0301652	
KA BG08-L 3P-0300-PNP	0301622	
KA BG08-L 3P-0500-PNP	0301623	
KA BW05-L 3P-0300	0301650	
KA BW08-L 3P-0300-NPN	0301602	
KA BW08-L 3P-0300-PNP	0301594	
KA BW08-L 3P-0500-NPN	9641116	
KA BW08-L 3P-0500-PNP	0301502	
<b>Cable extensions</b>		
KV BW08-SG08 3P-0030-PNP	0301495	
KV BW08-SG08 3P-0100-PNP	0301496	
KV BW08-SG08 3P-0200-PNP	0301497	

⑰ Two sensors (closer/NO) are required for each gripper, plus extension cables as an option.

⑰ Please note the minimum permitted bending radii for the sensor cables, which are generally 35 mm.

### Inductive proximity switches

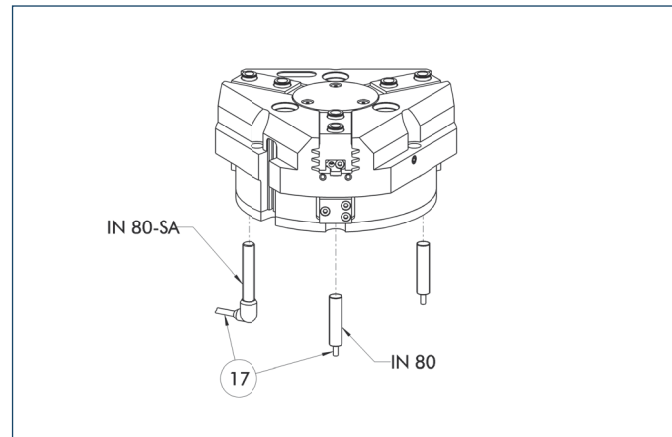

⑰ Cable outlet

End position monitoring for direct mounting

Description	ID	Recommended product
<b>Inductive proximity switches</b>		
IN 80-S-M8	0301478	•
IN 80-S-M12	0301578	
INK 80-S	0301550	
<b>Inductive proximity switch with lateral outlet</b>		
IN 80-S-M12-SA	0301587	
IN 80-S-M8-SA	0301483	•
INK 80-S-SA	0301566	
<b>Connection cables</b>		
KA BG08-L 3P-0300-PNP	0301622	
KA BG08-L 3P-0500-PNP	0301623	
KA BG12-L 3P-0500-PNP	30016369	
KA BW08-L 3P-0300-PNP	0301594	
KA BW08-L 3P-0500-PNP	0301502	
KA BW12-L 3P-0300-PNP	0301503	
KA BW12-L 3P-0500-PNP	0301507	
<b>Cable extensions</b>		
KV BG12-SG12 3P-0030-PNP	0301999	
KV BG12-SG12 3P-0060-PNP	0301998	
KV BW08-SG08 3P-0030-PNP	0301495	
KV BW08-SG08 3P-0100-PNP	0301496	
KV BW08-SG08 3P-0200-PNP	0301497	
KV BW12-SG12 3P-0030-PNP	0301595	
KV BW12-SG12 3P-0100-PNP	0301596	
KV BW12-SG12 3P-0200-PNP	0301597	

⑰ Two sensors (closer/NO) are required for each gripper, plus extension cables as an option.

⑰ Please note the minimum permitted bending radii for the sensor cables, which are generally 35 mm.

## Cylindrical Reed Switches

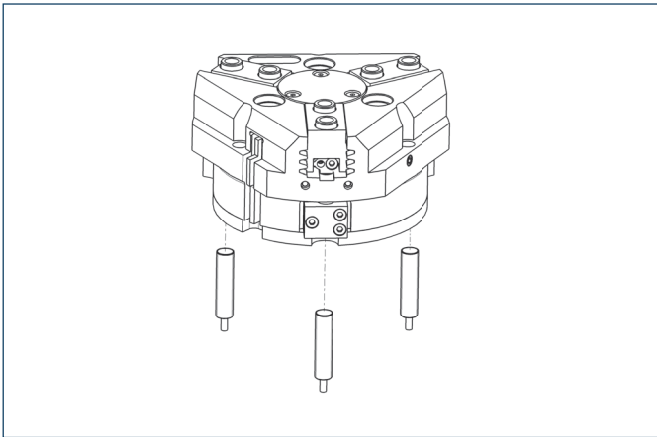

End position monitoring mounted with mounting kit

Description	ID
Mounting kit for proximity switch	
AS-RMS 80 PGN/PZN-plus 160-380	<b>0377727</b>
Reed Switches	
RMS 80-S-M8	<b>0377721</b>

- ① Two sensors (closer/NO) are required for each gripper, plus extension cables as an option.
- ① This mounting kit needs to be ordered optionally as an accessory.
- ① Please note the minimum permitted bending radii for the sensor cables, which are generally 35 mm.

## Analog position sensor

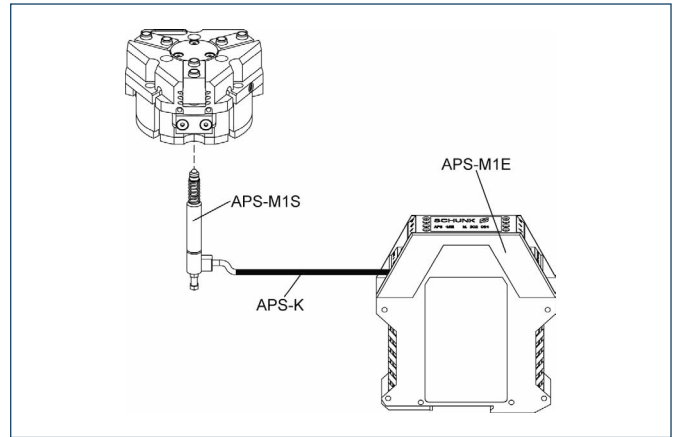

Analog multi position monitoring for any desired positions

Description	ID
Mounting kit	
AS-APS-M1-160/1 and 240/2	<b>0302083</b>
AS-APS-M1-240/1	<b>0302087</b>
Connection cables	
APS-K0200	<b>0302066</b>
APS-K0700	<b>0302068</b>
Electronic Processor	
APS-M1E	<b>0302064</b>
Sensor	
APS-M1S	<b>0302062</b>

- ① When using an APS system, for each gripper a mounting kit (AS-APS), an APS sensor (APS-M1S, incl. 3 m cable) as well as an electronics (APS-M1e) are required.
- ① An extension cable (APS-K) can be connected between the sensor and the electronics as an option. The max. cable length between the sensor and the electronics is 10 m, between the electronics and their control unit (PLC) it is max. 1 m.



You can find more detailed information and individual parts of the above-mentioned accessories in the "Accessories" catalog section.

## Flexible Position Sensor

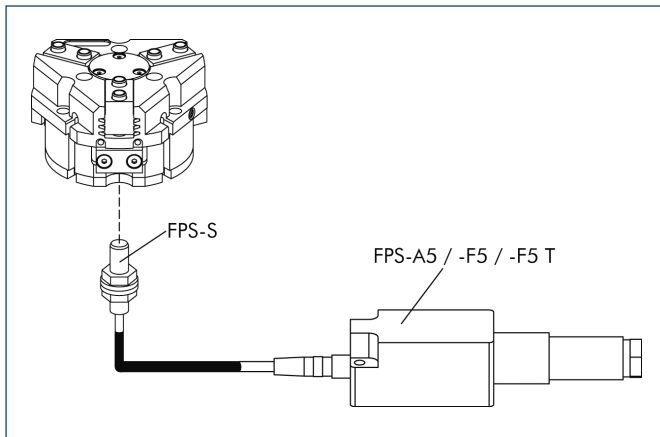

Flexible position monitoring of up to five positions

Description	ID
Mounting kit for FPS	
AS-PGN/PZN-plus 240/1	0301643
AS-PGN/PZN-plus 240/2	0301644
Electronic Processor	
FPS-F5	0301805
FPS-F5 T	0301807
Sensor	
FPS-S M8	0301704

① When using a FPS system, a FPS sensor (FPS-S) and a control unit (FPS-F5 / F5 T or A5) are required for each gripper as well as a mounting kit (AS), if listed. Cable extensions (KV) are available as options in the "Accessories" catalog section.

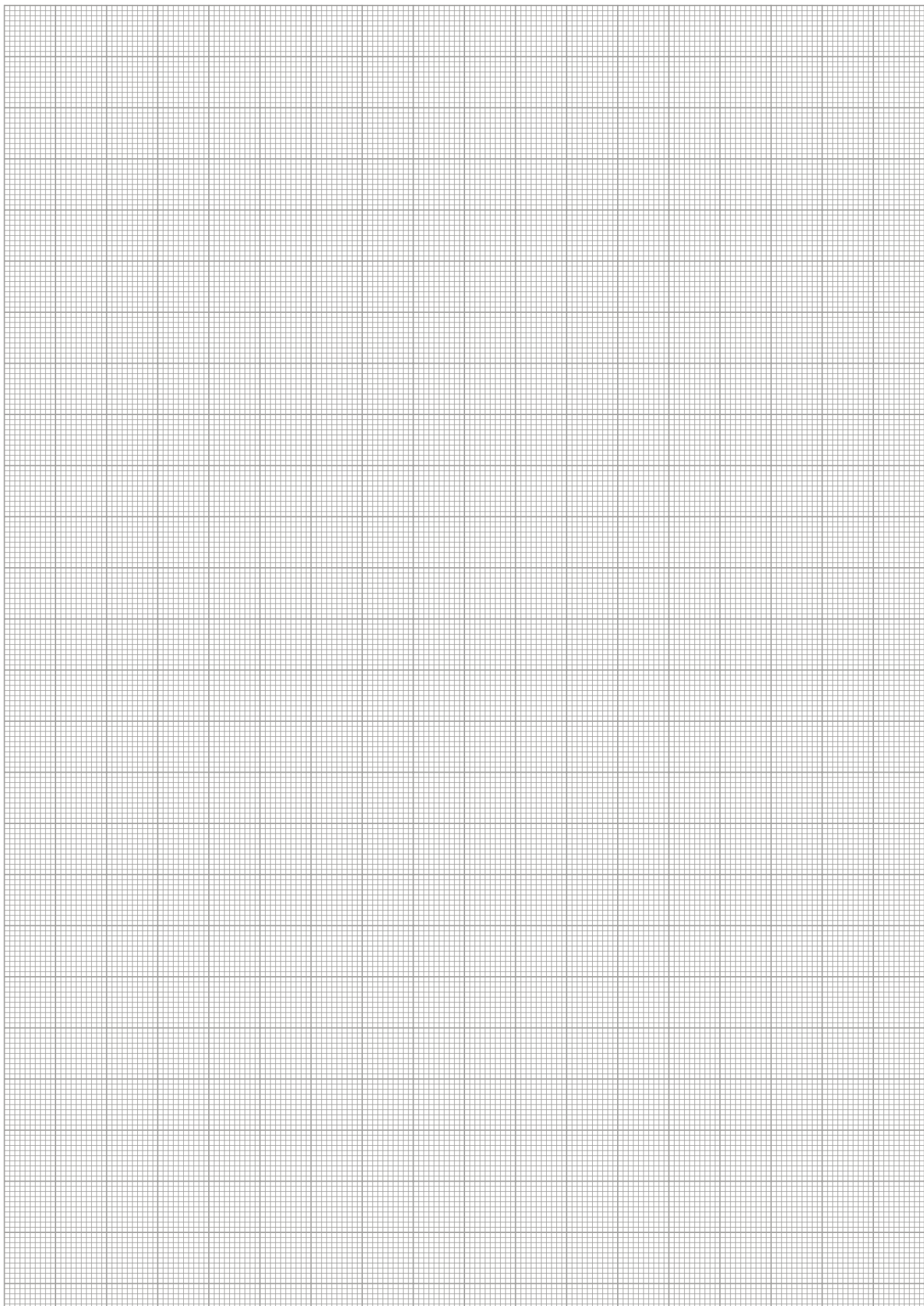

# PZN-plus 300

Pneumatic • 3-Finger Centric Gripper • Universal Gripper



## Gripping force, I.D. gripping

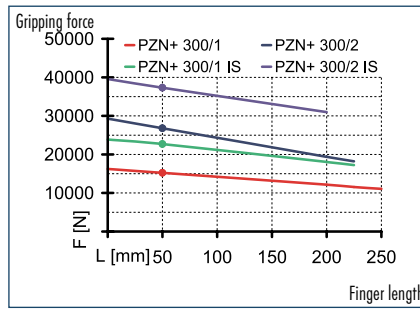

## Gripping force, O.D. gripping

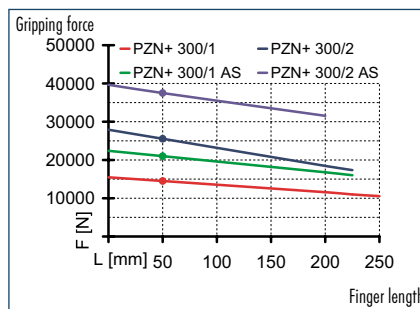

## Finger load

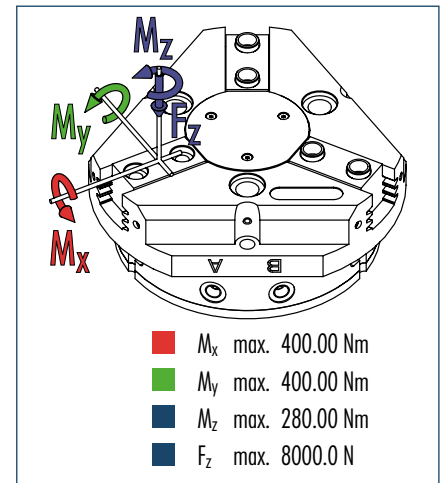

① The indicated moments and forces are static values, apply per base jaw and may occur simultaneously.  $M_y$  may arise in addition to the moment generated by the gripping force itself. If the max. permitted finger weight is exceeded, it is imperative to throttle the air pressure so that the jaw movement occurs without any hitting or bouncing. Service life may be reduced.

## Technical data

Description	PZN-plus 300-1	PZN-plus 300-2	PZN-plus 300-1-AS	PZN-plus 300-2-AS	PZN-plus 300-1-IS	PZN-plus 300-2-IS
ID	0303317	0303417	0303517	0303617	0303547	0303647
Stroke per finger [mm]	35	20	35	20	35	20
Closing force [N]	14500	25500	21000	35500		
Opening force [N]	15200	16800			22700	37300
Min. spring force [N]			6500	10000	7500	10500
Weight [kg]	33	33	43.5	43.5	43.5	43.5
Recommended workpiece weight [kg]	72.5	127.5	72.5	127.5	72.5	127.5
Air consumption per double stroke [cm <sup>3</sup> ]	2850	2850	5050	5050	5050	5050
Min./max. operating pressure [bar]	2/8	2/8	4/6.5	4/6.5	4/6.5	4/6.5
Nominal operating pressure [bar]	6	6	6	6	6	6
Closing/opening time [s]	1.3/1.3	1.3/1.3	1.2/2.5	1.2/2.5	2/1.2	2/1.2
Max. permitted finger length [mm]	250	225	225	200	225	200
Max. permitted weight per finger [kg]	11.5	11.5	11.5	11.5	11.5	11.5
IP class	40	40	40	40	40	40
Min./max. ambient temperature [°C]	-10/90	-10/90	-10/90	-10/90	-10/90	-10/90
Repeat accuracy [mm]	0.05	0.05	0.05	0.05	0.05	0.05
Cleanroom class						
ISO-classification 14644-1	5	5	5	5	5	5

## OPTIONS and their characteristics

	37303317	37303417	37303517	37303617	37303547	37303647
Dust-protection version	37303317	37303417	37303517	37303617	37303547	37303647
IP class	64	64	64	64	64	64
Weight [kg]	35.5	35.5	46	46	46	46
Anti-corrosion version	38303317	38303417	38303517	38303617	38303547	38303647
High-temperature version	39303317	39303417	39303517	39303617	39303547	39303647
Min./max. ambient temperature [°C]	-10/130	-10/130	-10/130	-10/130	-10/130	-10/130
Precision version	0303347	0303447	0303497	0303597		

## Main view

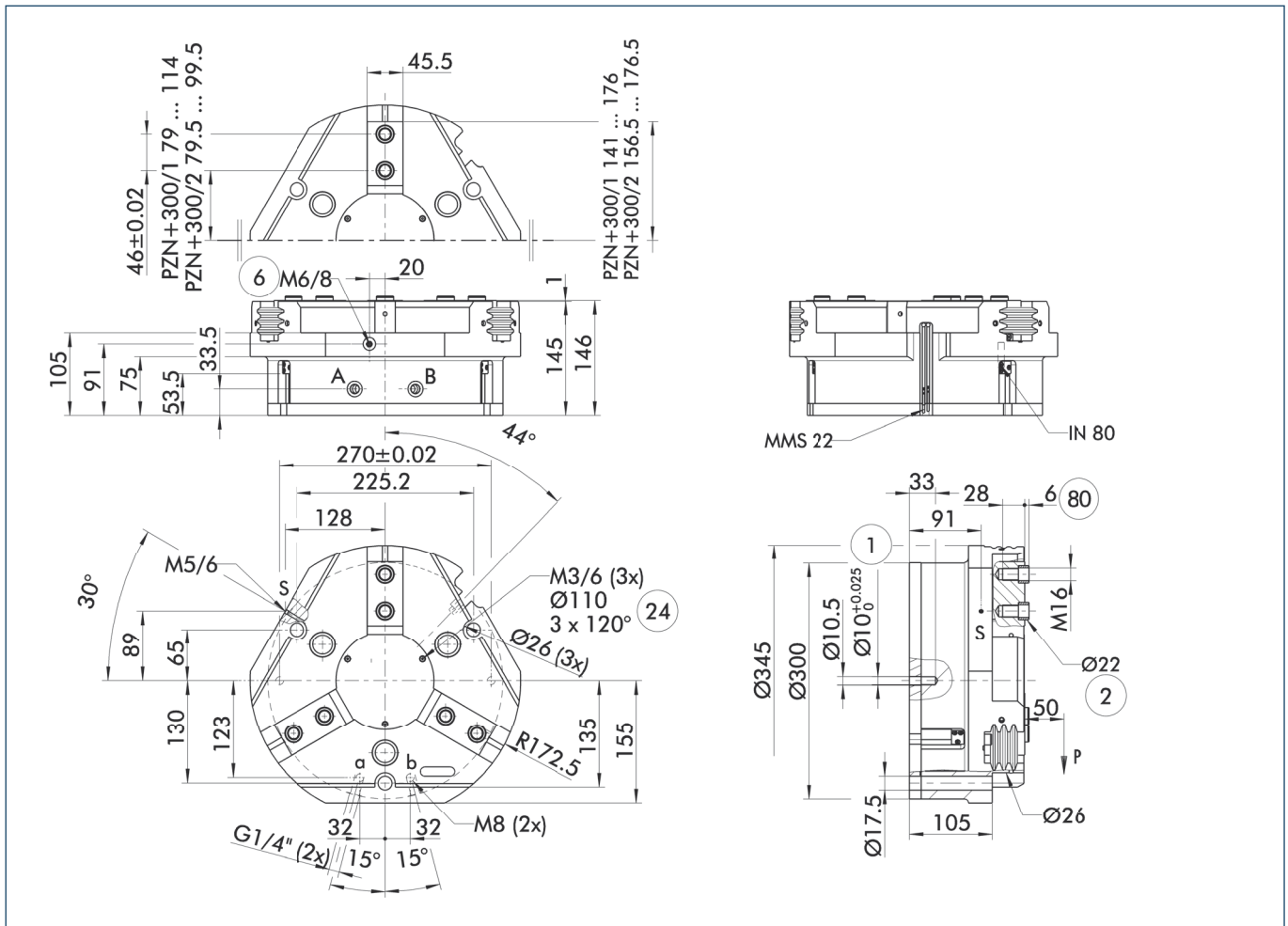

The drawing shows the gripper in the basic version with closed jaws, the dimensions do not include the options described below.

① The SDV-P pressure maintenance valve can also be used for I.D. or O.D. gripping alternatively or in addition to the spring-loaded, mechanical gripping force maintenance device (see "Accessories" catalog section).

- A, a Main/direct connection, gripper opening
- B, b Main/direct connection, gripper closing
- S Air purge connection
- ① Gripper connection
- ② Finger connection
- ⑥ Lubricating nipple connection
- ②④ Bolt circle
- ⑧⑩ Depth of the centering sleeve hole in the matching part

## Hose-free direct connection

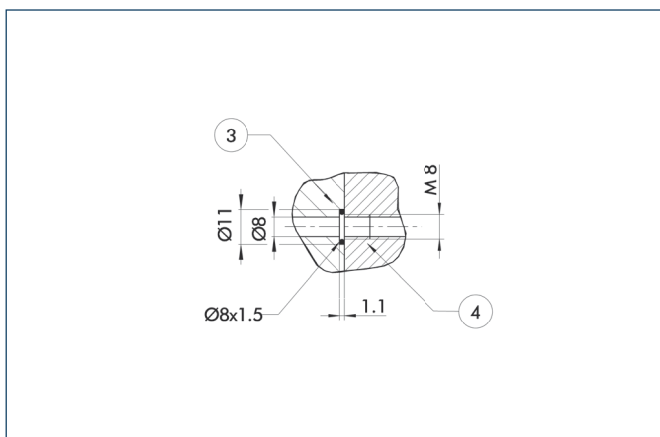

- ③ Adapter
- ④ Gripper

The direct connection is used for supplying compressed air without hoses. Instead, the pressure medium is fed through bore-holes in the mounting plate.

## AS/IS gripping force maintenance device

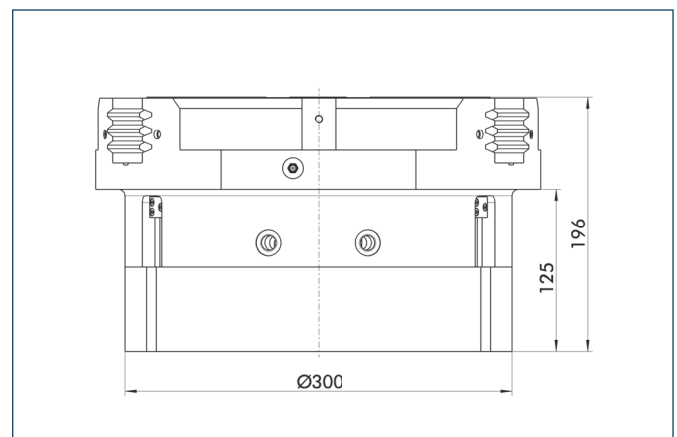

The mechanical gripping force maintenance device ensures a minimum gripping force even in case of pressure drop. This acts as closing force in the AS version, and as opening force in the IS version. In addition, the gripping force maintenance device can also be used for increasing the gripping force or for single-acting gripping.

# PZN-plus 300

Pneumatic • 3-Finger Centric Gripper • Universal Gripper

## Dust-protection version

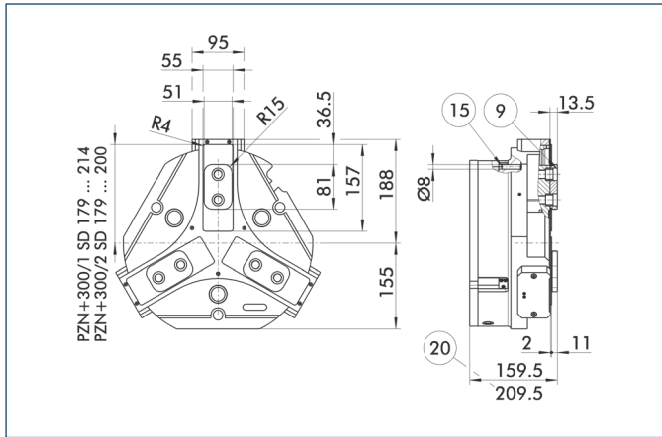

- ⑨ For mounting screw connection diagram, see basic version
- ⑮ Sealing bolt
- ⑳ For AS / IS version

The "dust-protection" option increases the degree of protection against penetrating substances. The screw connection diagram shifts by the height of the intermediate jaw. The finger length is still measured from the upper edge of the gripper housing.

## Precision version

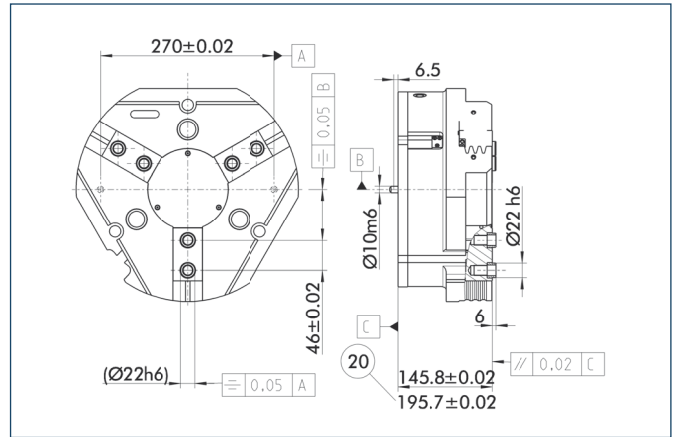

- ⑳ For AS / IS version

The indicated tolerances just refer to the types of precision versions shown in the chart of technical specifications. All other types of precision versions are available on request.

## Spring-loaded pressure piece

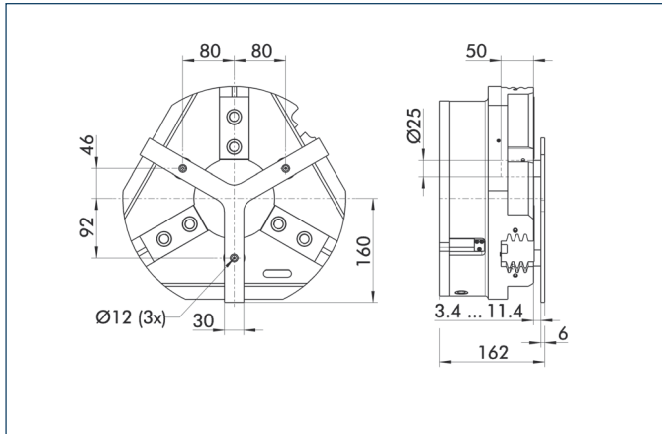

For spring-supported positioning of the workpiece against a stop after the gripper has opened. Especially developed for loading machines.

Description	ID	Stroke	Min. force
Spring-loaded pressure piece			
A-PZN-plus/DPZ-plus 300	0303727	8 mm	160 N

- ① The pressure piece cannot be combined with the dust-protection version. Please contact us if you require a special pressure piece.

## Force measuring jaws

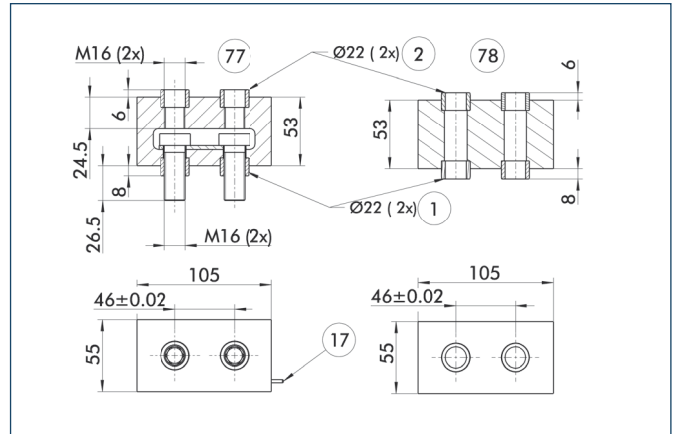

- ① Gripper connection
- ② Finger connection
- ⑰ Cable outlet
- ⑦⑦ Active intermediate jaws
- ⑦⑧ Passive intermediate jaws

Force measuring jaws measure gripping forces, but can also determine workpiece weights or dimensional deviations. There are active and passive intermediate jaws (FMS-ZBA or FMS-ZBP). At least one active force measuring jaw is required per gripper, the rest can be passive. For each active jaw, a FMS-A1 control unit and a FMS-A connection cable are required.

Description	ID
Active intermediate jaws	
FMS-ZBA 300	0301846
Passive intermediate jaws	
FMS-ZBP 300	0301847
Electronic Processor	
FMS-A2	0301811
Connection cables	
FMS-AK0200	0301820
FMS-AK0500	0301821
FMS-AK1000	0301822
FMS-AK2000	0301823

You can find more detailed information and individual parts of the above-mentioned accessories in the "Accessories" catalog section.

### Finger blanks

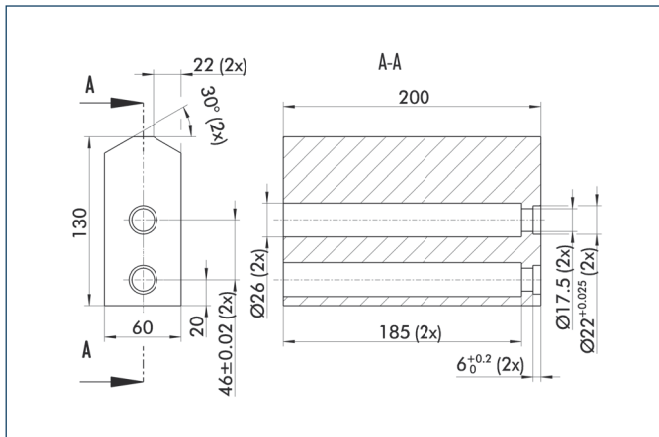

Finger blanks for customized subsequent machining

Description	ID	Material	Scope of delivery
Finger blanks			
ABR-plus 300	0300016	Aluminum	1
SBR-plus 300	0300026	16 MnCr 5	1

### Electronic magnetic switches

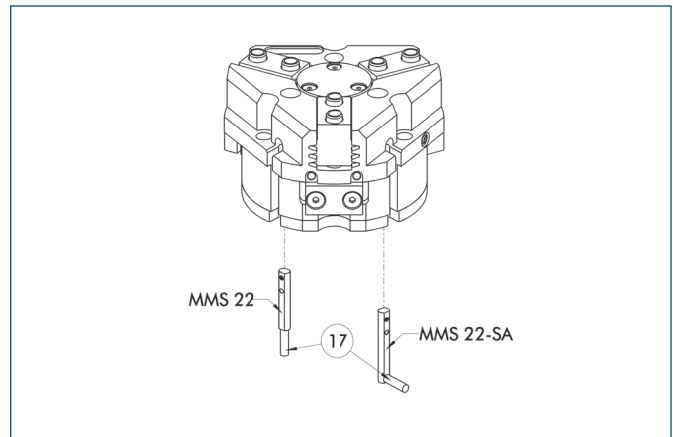

⑰ Cable outlet

End position monitoring for mounting in the C-slot

Description	ID	Recommended product
<b>Electronic magnetic switches</b>		
MMS 22-S-M5-PNP	0301438	
MMS 22-S-M5-NPN	0301439	
MMS 22-S-M8-PNP	0301432	•
MMS 22-S-M8-NPN	0301433	
MMSK 22-S-PNP	0301434	
MMSK 22-S-NPN	0301435	
<b>Electronic magnetic switches with lateral cable outlet</b>		
MMS 22-S-M5-PNP-SA	0301448	
MMS 22-S-M5-NPN-SA	0301449	
MMS 22-S-M8-PNP-SA	0301442	•
MMS 22-S-M8-NPN-SA	0301443	
MMSK 22-S-PNP-SA	0301444	
MMSK 22-S-NPN-SA	0301445	
<b>Reed Switches</b>		
RMS 22-S-M8	0377720	•
<b>Connection cables</b>		
KA BG05-L 3P-0300	0301652	
KA BG08-L 3P-0300-PNP	0301622	
KA BG08-L 3P-0500-PNP	0301623	
KA BW05-L 3P-0300	0301650	
KA BW08-L 3P-0300-NPN	0301602	
KA BW08-L 3P-0300-PNP	0301594	
KA BW08-L 3P-0500-NPN	9641116	
KA BW08-L 3P-0500-PNP	0301502	
<b>Cable extensions</b>		
KV BW08-SG08 3P-0030-PNP	0301495	
KV BW08-SG08 3P-0100-PNP	0301496	
KV BW08-SG08 3P-0200-PNP	0301497	

⑰ Two sensors (closer/NO) are required for each gripper, plus extension cables as an option.

⑰ Please note the minimum permitted bending radii for the sensor cables, which are generally 35 mm.



You can find more detailed information and individual parts of the above-mentioned accessories in the "Accessories" catalog section.



## Inductive proximity switches

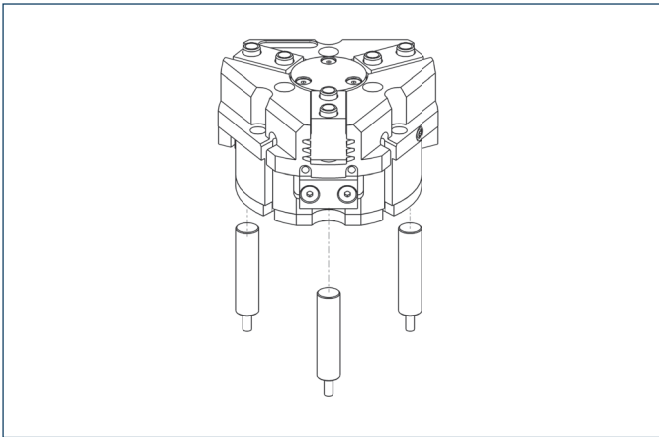

End position monitoring for direct mounting

Description	ID	Recommended product
<b>Inductive proximity switches</b>		
IN 80-S-M8	0301478	•
IN 80-S-M12	0301578	
INK 80-S	0301550	
<b>Connection cables</b>		
KA BG08-L 3P-0300-PNP	0301622	
KA BG08-L 3P-0500-PNP	0301623	
KA BG12-L 3P-0500-PNP	30016369	
KA BW08-L 3P-0300-PNP	0301594	
KA BW08-L 3P-0500-PNP	0301502	
KA BW12-L 3P-0300-PNP	0301503	
KA BW12-L 3P-0500-PNP	0301507	
<b>Cable extensions</b>		
KV BG12-SG12 3P-0030-PNP	0301999	
KV BG12-SG12 3P-0060-PNP	0301998	
KV BW08-SG08 3P-0030-PNP	0301495	
KV BW08-SG08 3P-0100-PNP	0301496	
KV BW08-SG08 3P-0200-PNP	0301497	
KV BW12-SG12 3P-0030-PNP	0301595	
KV BW12-SG12 3P-0100-PNP	0301596	
KV BW12-SG12 3P-0200-PNP	0301597	

- ① Two sensors (closer/NO) are required for each gripper, plus extension cables as an option.
- ① Please note the minimum permitted bending radii for the sensor cables, which are generally 35 mm.

## Cylindrical Reed Switches

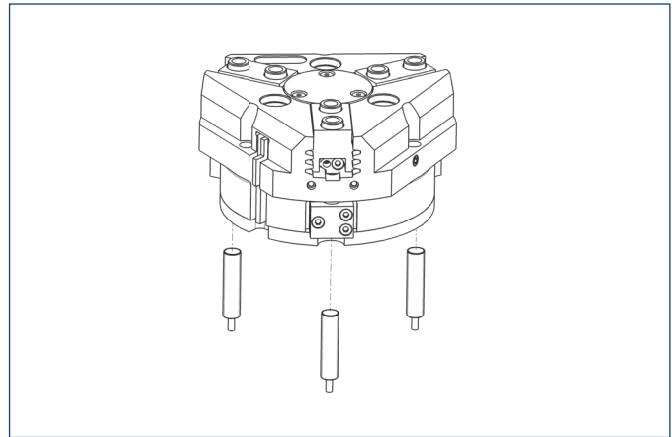

End position monitoring mounted with mounting kit

Description	ID
<b>Mounting kit for proximity switch</b>	
AS-RMS 80 PGN/PZN-plus 160-380	0377727
<b>Reed Switches</b>	
RMS 80-S-M8	0377721

- ① Two sensors (closer/NO) are required for each gripper, plus extension cables as an option.
- ① This mounting kit needs to be ordered optionally as an accessory.
- ① Please note the minimum permitted bending radii for the sensor cables, which are generally 35 mm.

### Analog position sensor

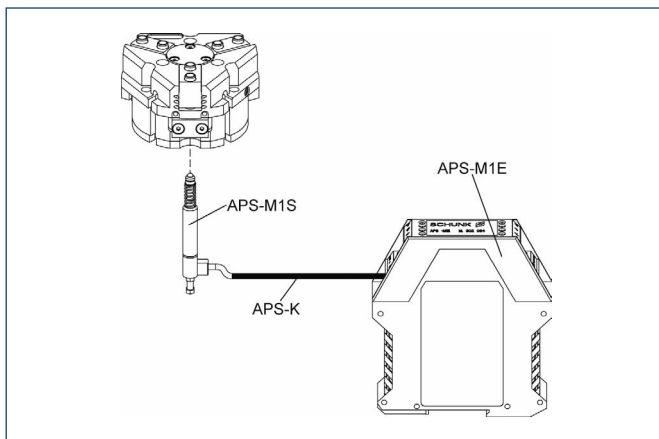

Analog multi position monitoring for any desired positions

Description	ID
<b>Mounting kit</b>	
AS-APS-M1-300/1	0302088
AS-APS-M1-300/2	0302089
<b>Connection cables</b>	
APS-K0200	0302066
APS-K0700	0302068
<b>Electronic Processor</b>	
APS-M1E	0302064
<b>Sensor</b>	
APS-M1S	0302062

- ① When using an APS system, for each gripper a mounting kit (AS-APS), an APS sensor (APS-M 1S, incl. 3 m cable) as well as an electronics (APS-M1e) are required.
- ① An extension cable (APS-K) can be connected between the sensor and the electronics as an option. The max. cable length between the sensor and the electronics is 10 m, between the electronics and their control unit (PLC) it is max. 1 m.

### Flexible Position Sensor

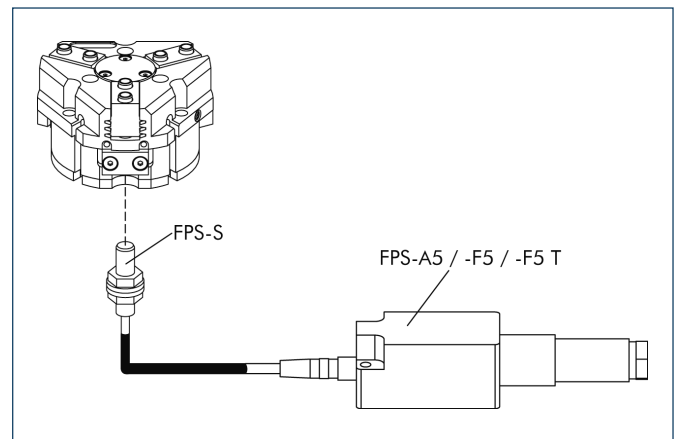

Flexible position monitoring of up to five positions

Description	ID
<b>Mounting kit for FPS</b>	
AS-PGN/PZN-plus 300-2	0301642
<b>Electronic Processor</b>	
FPS-F5	0301805
FPS-F5 T	0301807
<b>Sensor</b>	
FPS-S M8	0301704

- ① When using a FPS system, a FPS sensor (FPS-S) and a control unit (FPS-F5 / F5 T or A5) are required for each gripper as well as a mounting kit (AS), if listed. Cable extensions (KV) are available as options in the "Accessories" catalog section.