



Precision Ball Splines

Robust rotary and linear motion integration for high-precision applications

Multi-Motion Performance and Stability

As automation spreads farther and wider into the industrial sector, the need for flexible solutions that address multi-axis motion exponentially grows. Thomson precision ball splines meet the demands of this trend by offering nearly friction-free linear and rotary motion integrated on a single shaft.



Merging Motions

Thanks to a design that incorporates one or more linear grooves that guide balls along the shaft, Thomson precision ball splines provide a low-friction path and enable transmission of torsional loads. Their unique ability to integrate rotary and linear motion on a single shaft gives designers more ways to compress an assembly, extend a stroke or distribute a load, and new flexibility to meet modern automation demands.

We Make Customization Standard

When you order Thomson precision ball splines that include machined ends, you will never need to worry about additional design time or hidden costs. Whether it's coaxial holes, external threads, single- or two-step reduction or ring grooves, our end machining options (see opposite page) feature set pricing and help get our splines into your hands quickly to keep your design projects on track.

Nut Options

To best accommodate your application requirements, two different nut options are available for Thomson precision ball splines.



Non-Flanged Spline Nut

This spline nut features a straight cylindrical shape and uses a key to mount it to the spline. While the nut includes a keyway and separate key, a matching keyway must be bored into the housing or block to that will be mounted on the nut.



Flanged Spline Nut

As this spline nut only requires a rough bore and mounting holes drilled and tapped to secure the flange to the housing, it is much easier to install.

End Machining Options

Depending on your shape requirements, Thomson can custom machine spline shafts to match your exact specifications. Customizations may include a larger diameter on both ends or in the center of a shaft.



A Look Inside Precision Ball Splines

The design of Thomson precision ball splines enables nearly friction-free motion by restricting physical contact to tangential points of rolling balls guided by ball screw threads and the raceways within a nut. This rotary guidance is then augmented by adding one or more linear grooves, or splines, along the shaft, which facilitate front-to-back movements. These grooves provide a low-friction linear path while simultaneously enabling transmission torsional loads. This design concept is ideal for applications that must account for high speed, vibration, impacts of loading and precise positioning requirements.

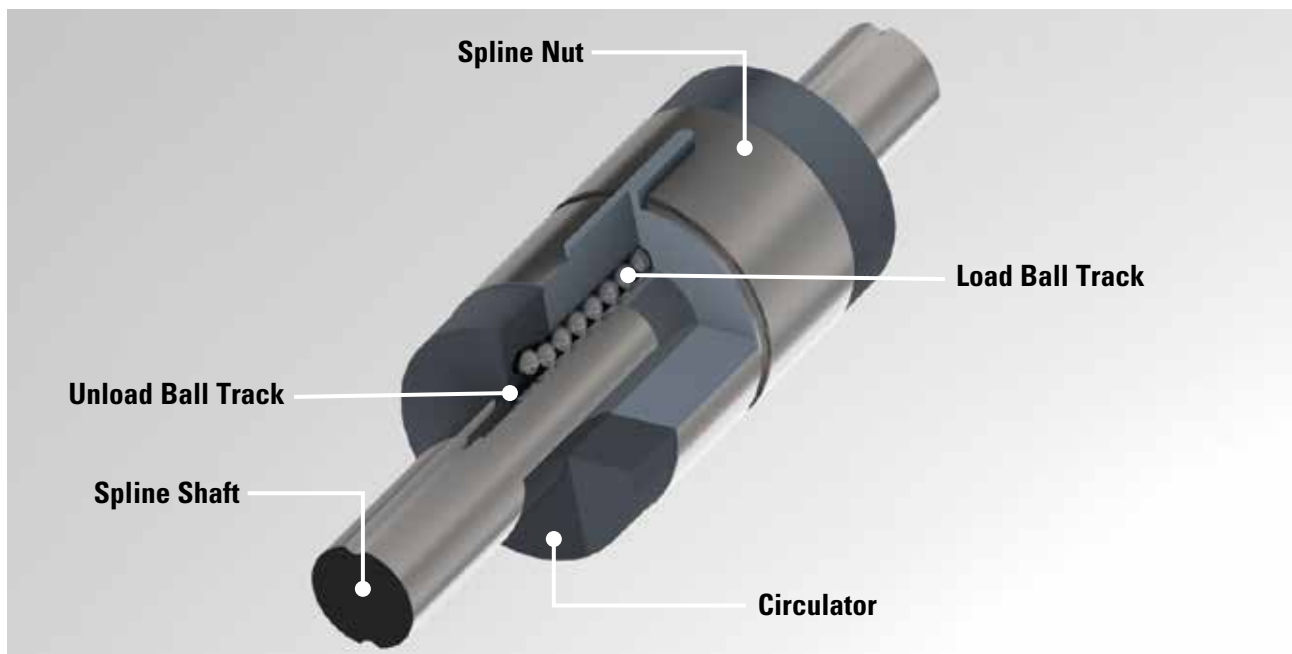

Highlights

High Load Capacity

Wide, precision-ground grooves allow for increased load-carrying capabilities as well as improved rigidity and stiffness for handling larger moment loads.

Zero Angular Clearance / Backlash

Groove design similar to Gothic arches allows for zero angular clearance and backlash, making the ball splines ideal for high-precision applications.

High Sensitivity

A 40° angular contact allows grooves to operate with minimal friction, while achieving optimal sensitivity.

Low-Maintenance Design

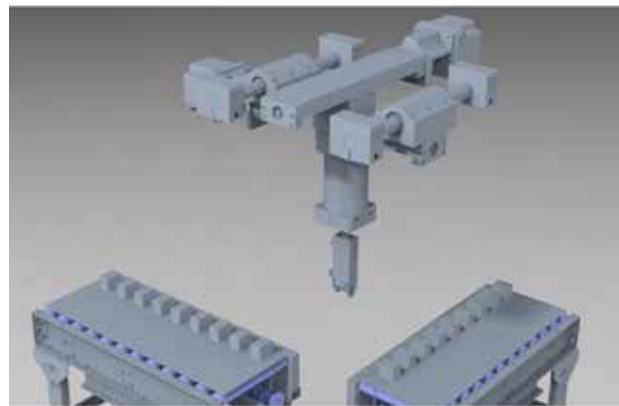
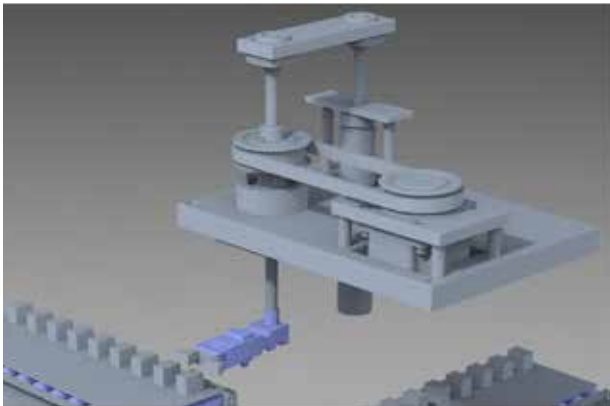

A simple, ball-retaining design allows for mess-free removal of the spline nut.

Technology and Feature Comparison



Thomson Precision Ball Splines	Thomson Linear Bearings & Guides
Fewer Components to Achieve Locational Movement	Larger List of Components and Assemblies
Easy Rotational Capacity	Complex XYZ Movement
Less Cost Due to Fewer Components	Higher Cost Due to Larger List of Components
Easier Integration	Complex Integration (Several Motors)
Precise and Faster Movements	Precise but Slower Movements

Design Considerations

Specifications	Thomson Precision Ball Splines	Thomson Linear Bearings & Guides
		
Size	16 mm	16 mm
Load Capacity	5346 N	2400 N
Cost	\$\$\$	\$\$
Rotational Moment Loads (Static)	46 N-m	NA
Speed	2 m/s	3 m/s
Type Applications	Rotational & Linear	Linear
Accuracy	Precision 56 Microns (0.002")	0.0001"
Life Expectancy	10x (under the same load)	100 km
Assembly Efficiency	1 Spline	2 Bearing Configuration

Note: The diameter size (16 mm) is used for comparison purposes only. Thomson precision ball splines are available in diameters from 6-50 mm.

Applications

Robotics

Faster movement and accurate positioning result in significant reductions in production time, which is critical for mass machining environments. Thomson precision ball splines simplify these systems by providing both linear and rotary motion on one shaft. Their robust capacity supplies a reliable option for tool holding in robotic applications such as CNC machining.

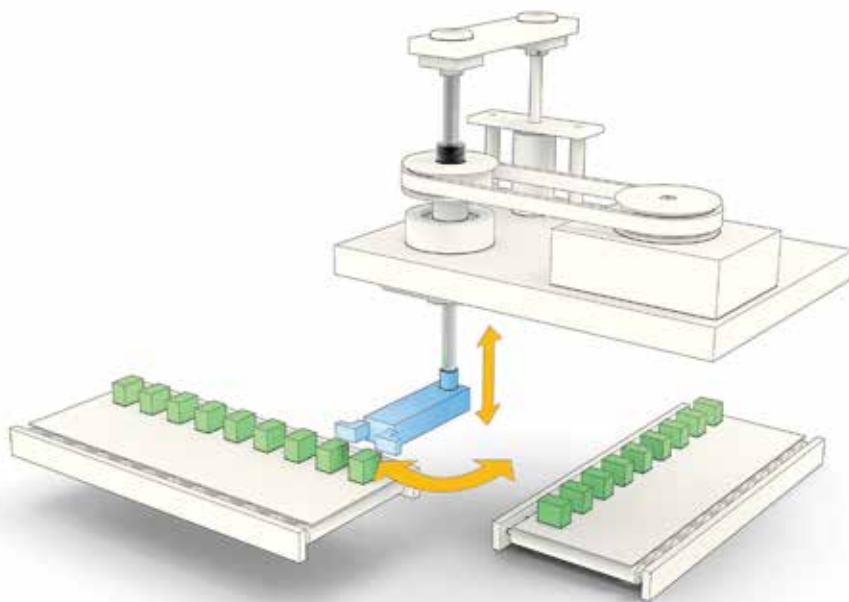
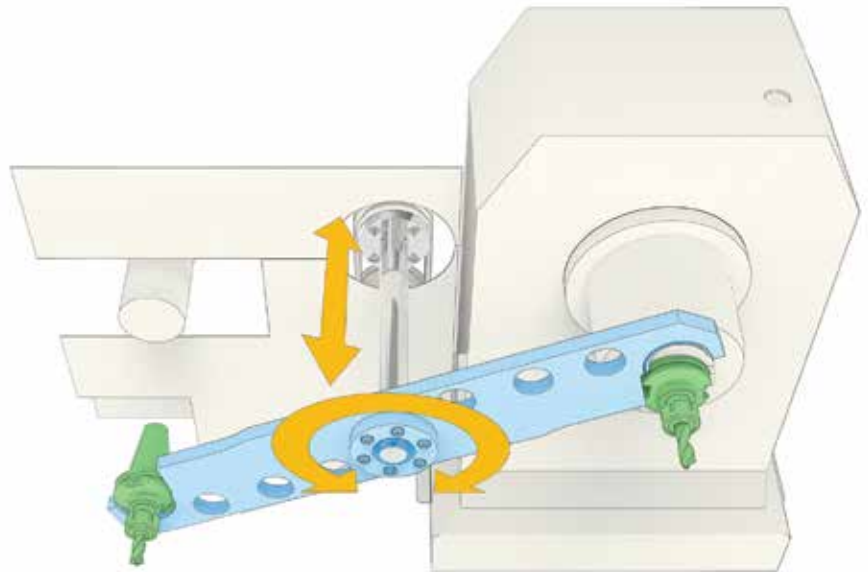

Packaging

Thomson precision ball splines simplify XYZ movement into linear and rotary motion, thereby reducing the number of parts and complexity required for picking up an item and placing it in another location. Fewer components and simpler designs result in lower costs, higher efficiencies, less maintenance and quicker lead times.

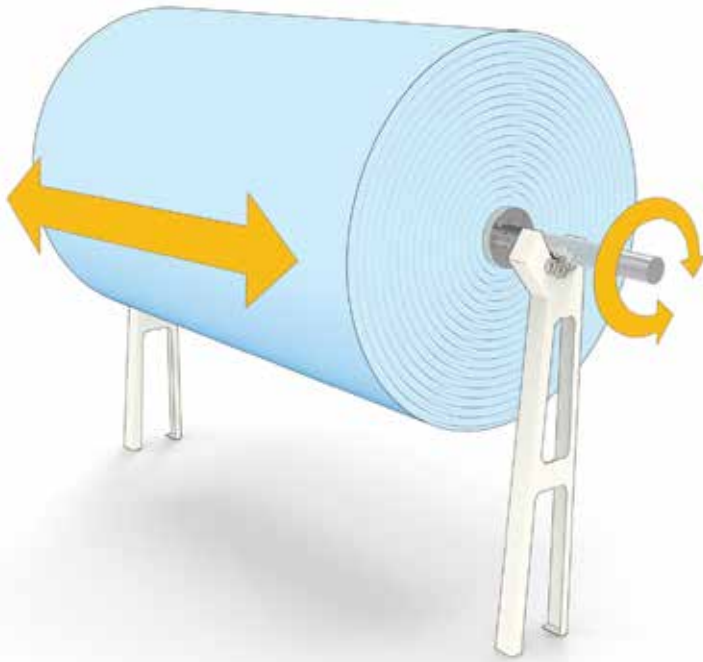

Rotating Drum for Paper Mill

The high load capacity of Thomson precision ball splines provides the required rigidity when they are challenged by heavy objects. In addition, the nut design helps lock the rotational movement when the application is at rest.

Machine Automation

The accuracy of Thomson precision ball splines makes them ideal for many machine automation applications. For example, on a honing machine, precision is critical in maintaining a steady combination of rotary and linear motion.

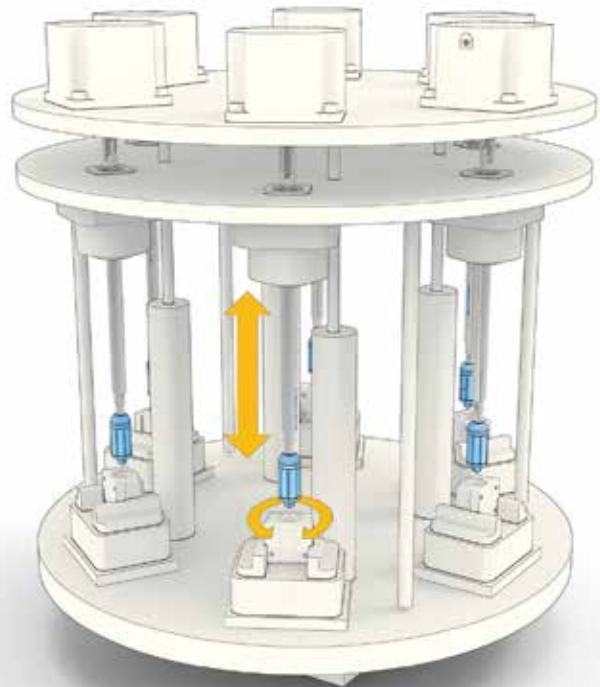

Ordering Keys

Spline Nut and Shaft Assemblies

1	2	3	4	5	6	7	8	9	10	11	12		
SPLA	025	R	S	N	S	–	PO	–	1	S	S	CTL	500.00
1. Spline Nut SPLA = Ball Spline Assembly 2. Diameter 006 = 6 mm 008 = 8 mm 010 = 10 mm 013 = 13 mm 016 = 16 mm 020 = 20 mm 025 = 25 mm 030 = 30 mm 040 = 40 mm 050 = 50 mm		3. Nut Flange Type F = Flanged R = Round 4. Nut Type S = Standard 5. Accuracy Grade N = Normal 6. Spline Shaft Type S = Solid		7. Preload PO = No Preload 8. Number of Spline Nuts¹ 9. Nut Surface Treatment S = Standard		10. Spline Surface Treatment S = Standard 11. Machining CTL = Cut To Length SM = Standard Machining 12. Overall Length² Length in millimeters, example: 500.00 equals 500 mm							

1. Maximum of 5 spline nuts per assembly.
2. Maximum length of 500 mm for diameters 6 and 8 mm, maximum length of 3000 mm for all other diameters.

Spline Nut

1	2	3	4	5
SPLN	025	R	S	S
1. Spline Nut SPLN = Ball Spline Nut 2. Diameter 006 = 6 mm 008 = 8 mm 010 = 10 mm 013 = 13 mm 016 = 16 mm 020 = 20 mm 025 = 25 mm 030 = 30 mm 040 = 40 mm 050 = 50 mm		3. Nut Flange Type F = Flanged R = Round 4. Nut Type S = Standard 5. Nut Surface Treatment S = Standard		

Spline Shaft

1	2	3	4	5	6	7
SPLS	025	N	S	S	CTL	500.00
1. Spline Shaft SPLS = Ball Spline Shaft 2. Diameter 006 = 6 mm 008 = 8 mm 010 = 10 mm 013 = 13 mm 016 = 16 mm 020 = 20 mm 025 = 25 mm 030 = 30 mm 040 = 40 mm 050 = 50 mm		3. Accuracy Grade N = Normal 4. Spline Shaft Type S = Solid 5. Shaft Surface Treatment S = Standard 6. Machining CTL = Cut To Length SM = Standard Machining 7. Length¹ Length in millimeters, example: 500.00 equals 500 mm				

1. Maximum length of 500 mm for diameters 6 and 8 mm, maximum length of 3000 mm for all other diameters.

Sizing & Selection Guidelines

Steps	Description
1. Set Operational Conditions	<ul style="list-style-type: none"> • Length / Stroke • Applied Torque and Load • Type of Mounting • Running Speed • Working Temperature • Number of Spline Nuts
2. Calculate Equivalent Bending Moment and Torque	<ul style="list-style-type: none"> • Use bending moment equations in Table 1. (page 18)
3. Select Appropriate Spline Shaft Size	<ul style="list-style-type: none"> • To define minimum shaft section modulus, use Equations 1-4. (pages 10-11) • To select spline shaft size, use Table 2. (page 19)
4. Check for Torsional Rigidity (Twist)	<ul style="list-style-type: none"> • To calculate twist angle, use Equation 5 and Table 2 (pages 11 and 19), or use charts on pages 12-15. • Is calculated twist less than twist limit? (Typically limit is 0.25 deg / 1000 mm) <ul style="list-style-type: none"> ○ if Yes, continue to Step 5. ○ if No, select bigger spline shaft size. Restart Step 4.
5. Check for Deflection	<ul style="list-style-type: none"> • To calculate deflection, use equations in Table 1 and cross section factors in Table 2. (pages 18-19) • Is calculated deflection less than deflection limit? <ul style="list-style-type: none"> ○ if Yes, continue to Step 6. ○ if No, select bigger spline shaft size. Restart Step 5.
6. Check for Critical Speed	<ul style="list-style-type: none"> • To calculate critical speed, use Equations 6-8 (page 20) or chart on page 21. • Is calculated critical speed higher than expected running speed? <ul style="list-style-type: none"> ○ if Yes, continue to Step 7. ○ if No, select bigger spline shaft. Restart Step 6.
7. Check for Life Expectancy	<ul style="list-style-type: none"> • To estimate expected life in km, use Equations 9-12 (page 22) or charts on pages 26-30. • Is expected life longer than life limit? <ul style="list-style-type: none"> ○ if Yes, you have selected the appropriate size for spline shaft. ○ if No, select bigger spline shaft size. Restart Step 7.
8. Review Operating Conditions	<ul style="list-style-type: none"> • General Maintenance • Lubrication • Storage • Installation

Spline Shaft Strength

As the spline shaft has been designed to absorb radial load and torque during operation, its strength must be taken into consideration when precision ball splines perform under extreme loading or torque.

Bending Load Applied on the Ball Spline

The maximum bending moment (M) can be attributed to multi-factor such as the end fixity methods, length of spline shaft, load capacity, etc. Equation (1) helps the user obtain the ideal length of spline shaft in order to be the reference of obtaining the ideal strength of ball spline.

$$(1) M = \sigma \cdot Z \text{ and } Z = \frac{M}{\sigma}$$

M : Bending moment (N-mm)

σ : Shaft permissible bending stress (98 N/mm²)

Z : Shaft section modulus (mm³)

Note: Refer to Table 2 for cross-section factors and secondary moments.

Torque Applied on the Operating Ball Spline

The maximum torque applied on the spline shaft can be calculated through maximum twisting moment (T). Equation (2) helps the user obtain the ideal length of spline shaft.

$$(2) T = \tau_a Z_p \text{ and } Z_p = \frac{T}{\tau_a}$$

T : Maximum twisting moment (N : mm)

τ_a : Shaft permissible twisting stress (49 N/mm²)

Z_p : Shaft polar section modulus (mm³)

Note: Refer to Table 2 for cross-section factors and secondary moments.

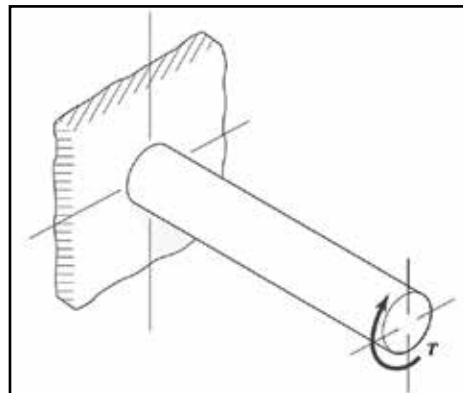

Bending Moment and Twisting Moment Applied Simultaneously on the Spline Shaft

To calculate the figure for both bending (M) and twisting moments (T) applied on the spline shaft via equation (3) and (4), get the equivalent bending moment (Me) and equivalent twisting moment (Te). Adopt the greater value from equations (3) and (4) to determine the ideal spline shaft length.

Equivalent Bending Moment

$$(3) \quad Me = \frac{M + \sqrt{M^2 + T^2}}{2} = \frac{M}{2} \left\{ 1 + \sqrt{1 + \left(\frac{T}{M}\right)^2} \right\}$$

$$Me = \sigma \cdot Z$$

Equivalent Twisting Moment

$$(4) \quad Te = \sqrt{M^2 + T^2} = M \cdot \sqrt{1 + \left(\frac{T}{M}\right)^2}$$

$$Te = \tau_a \cdot Z_p$$

Rigidity of the Spline Shaft

The rigidity of the spline shaft is expressed in torsion angle caused by twisting moment. The twisting angle should be limited to no further than 0.25° per 1000 mm.

$$(5) \quad \theta = 57.3 \frac{T \cdot L}{G \cdot Ip}$$

$$\text{Shaft Rigidity} = \text{Torsion Angle} / \text{Unit Length} = \frac{\theta \cdot \ell}{L} < \frac{1^\circ}{4}$$

θ : Torsion Angle (°)

L : Shaft Length (mm)

G : Shear Elastic Modulus ($7.9 \times 10^4 \text{N/mm}^2$)

ℓ : Unit Length (1000 mm)

Ip : Polar Moment of Inertia Ip (mm^4)

Note: Refer to Table 2 for cross-section factors and secondary moments.

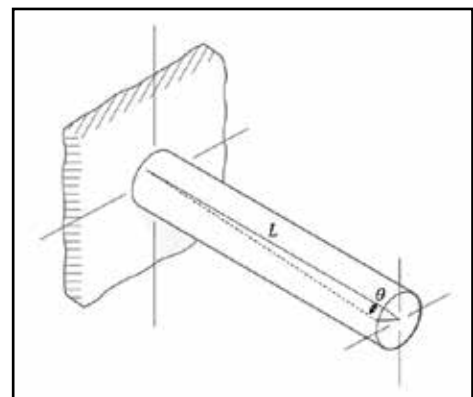

Spline Shaft Torsion Rigidity

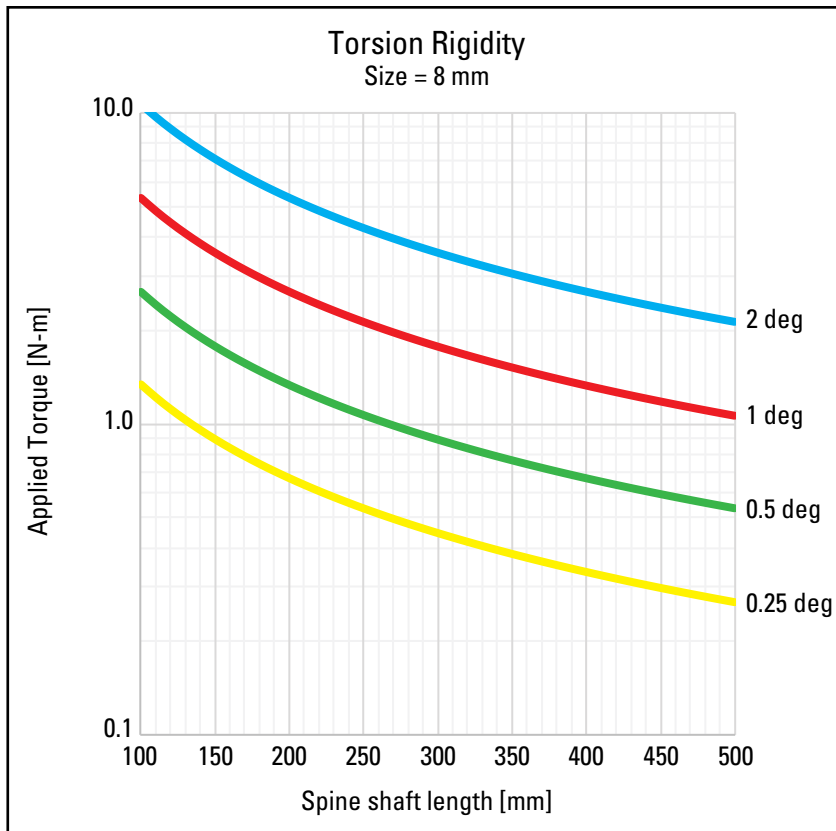
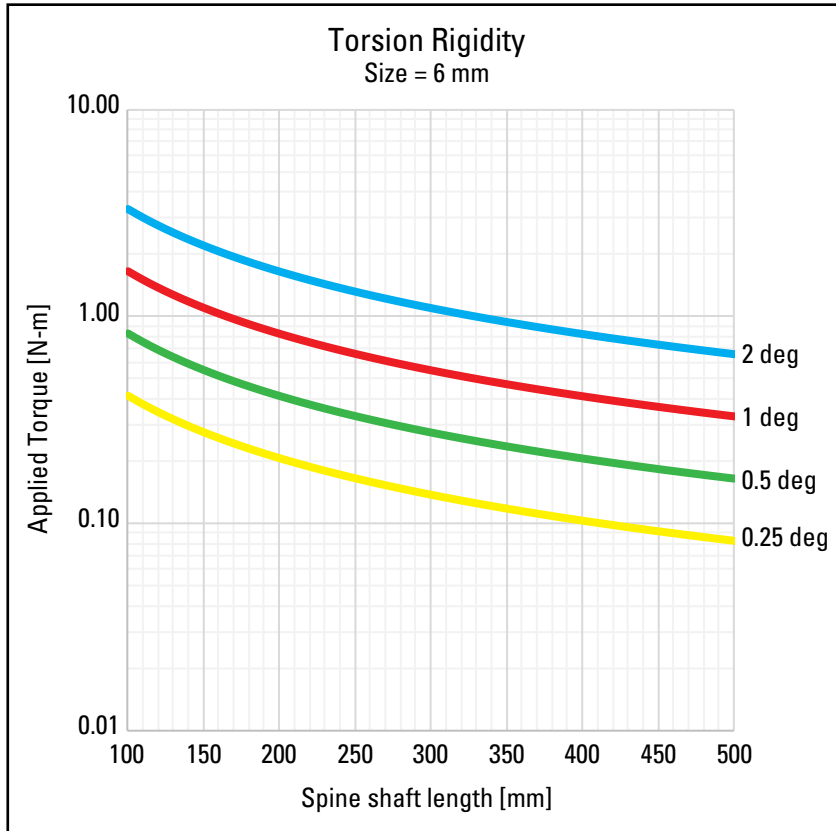

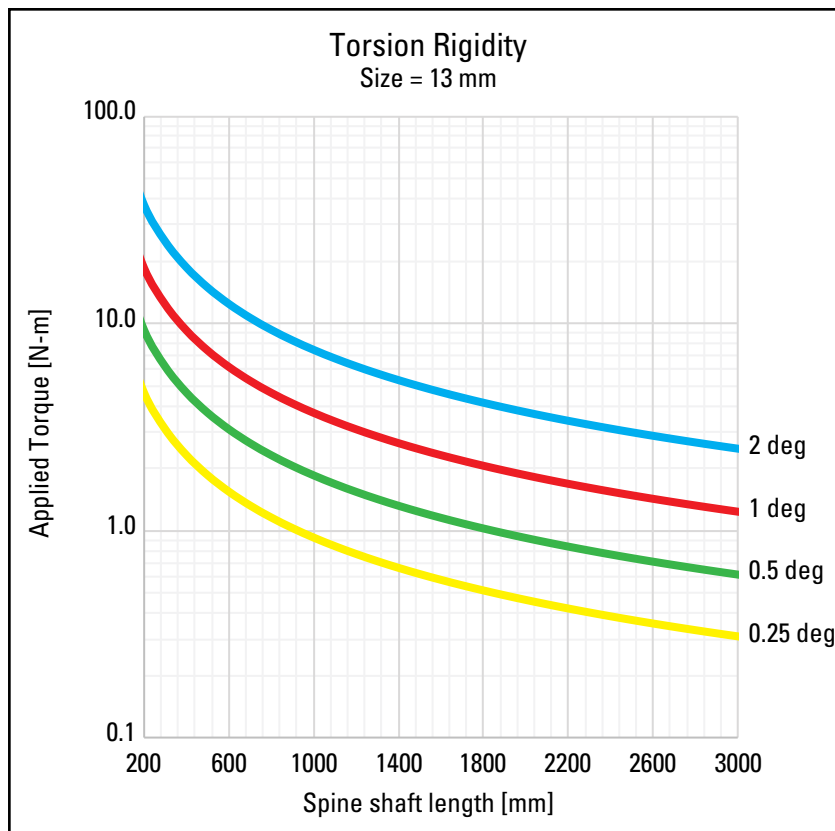
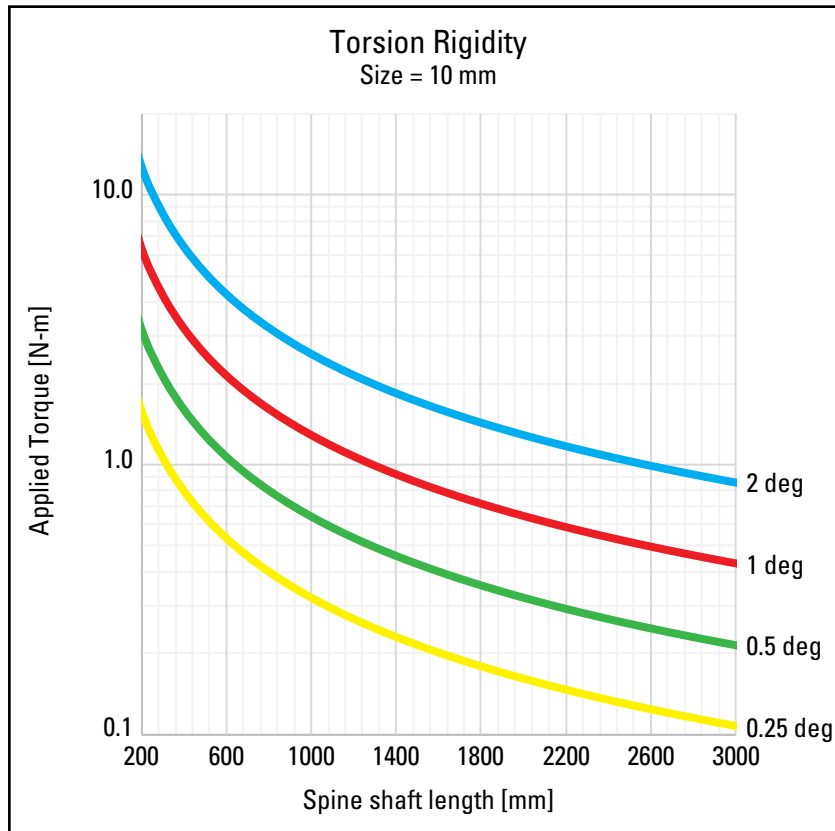

Spline Shaft Torsion Rigidity

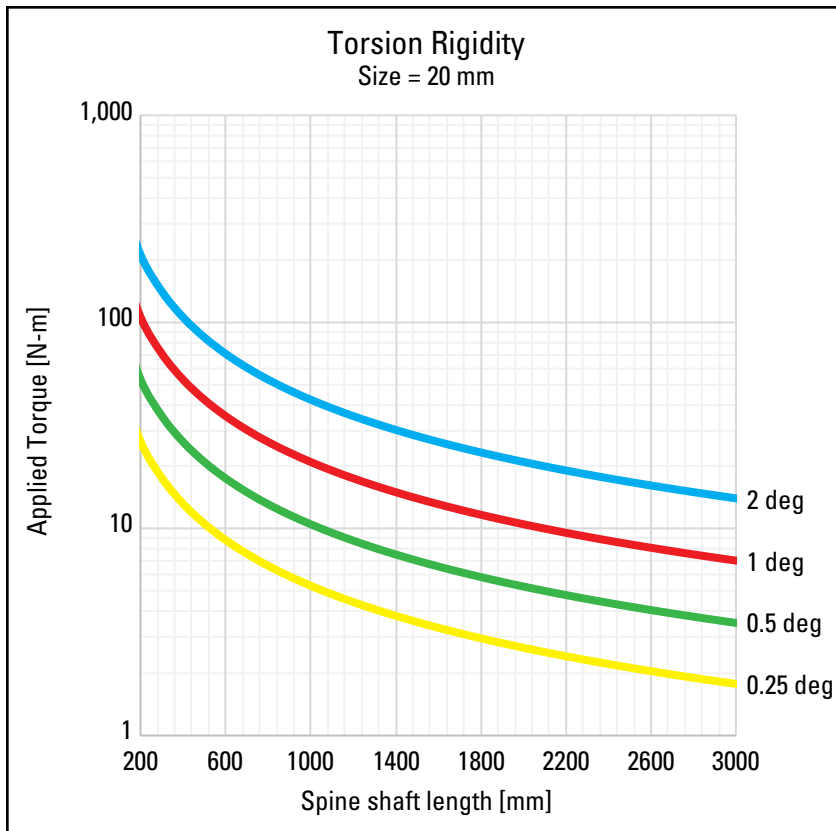
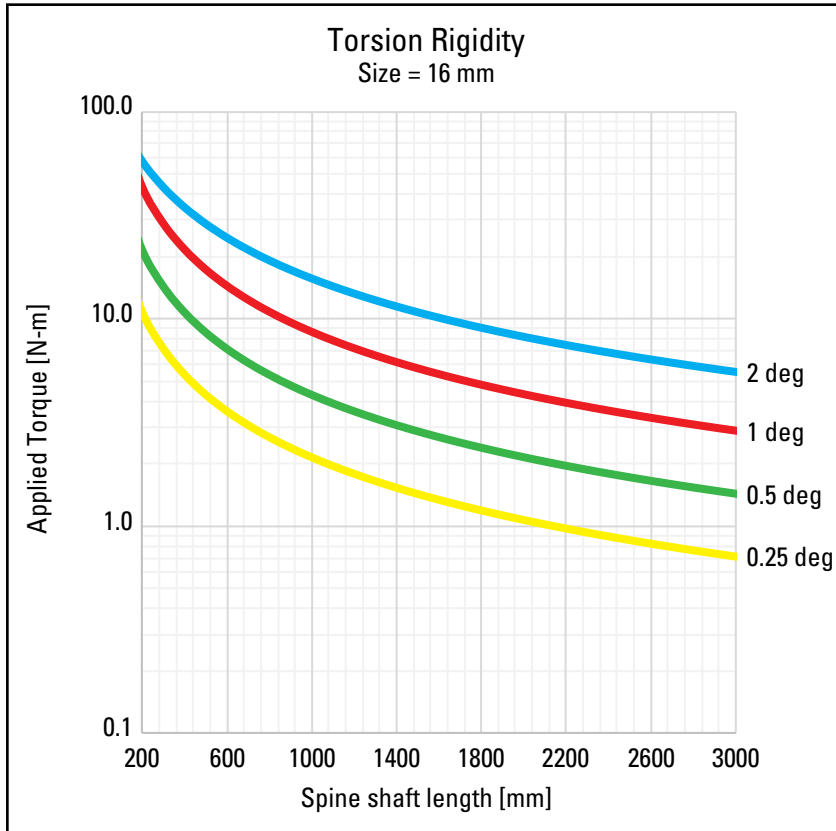

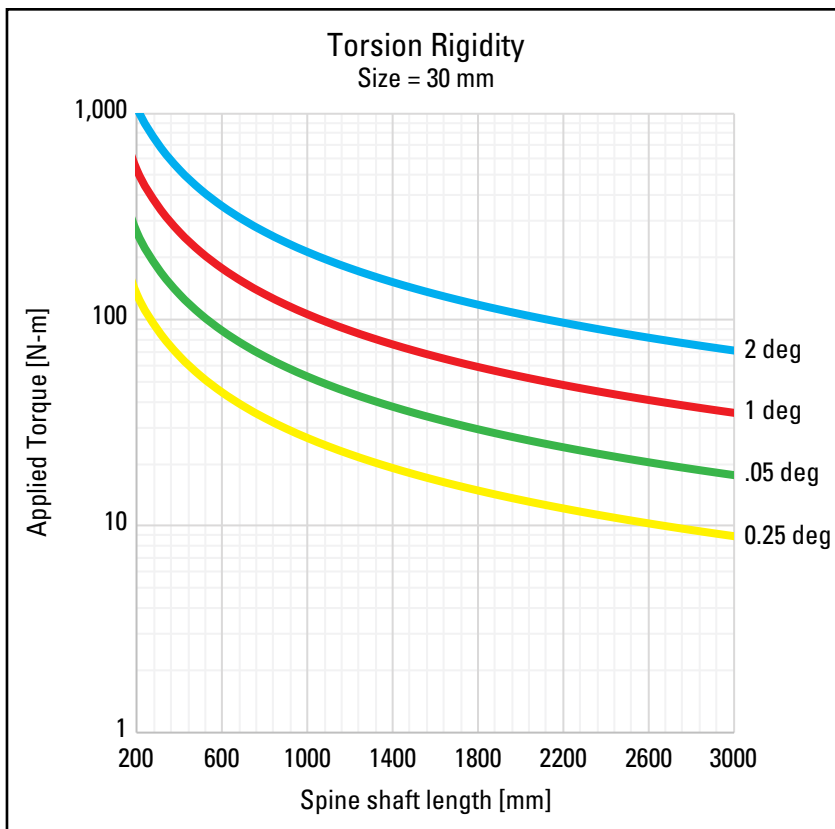
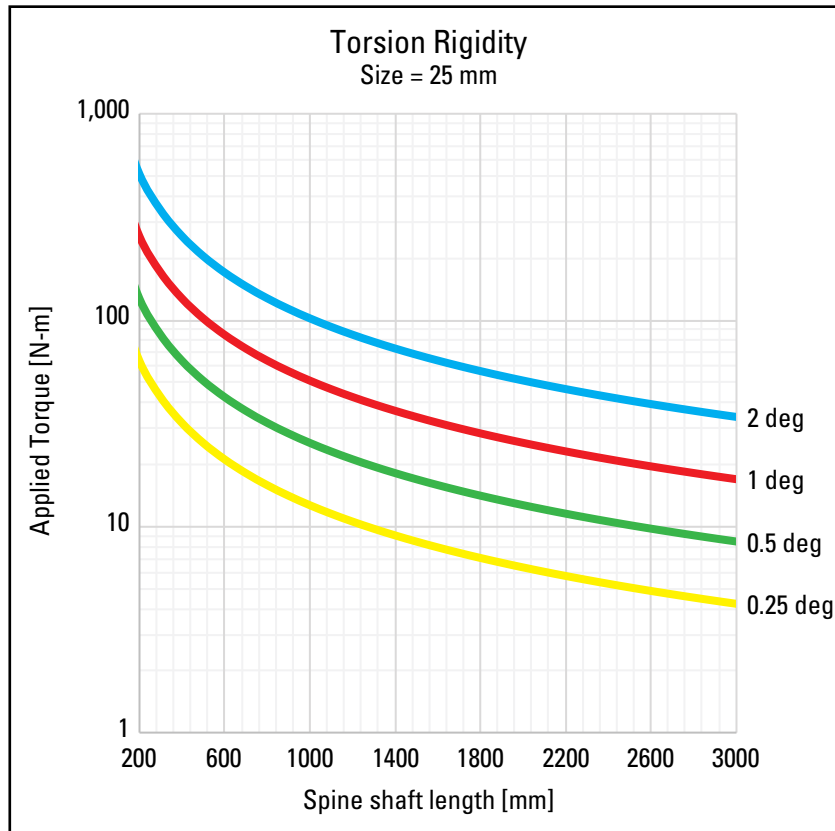

Spline Shaft Torsion Rigidity

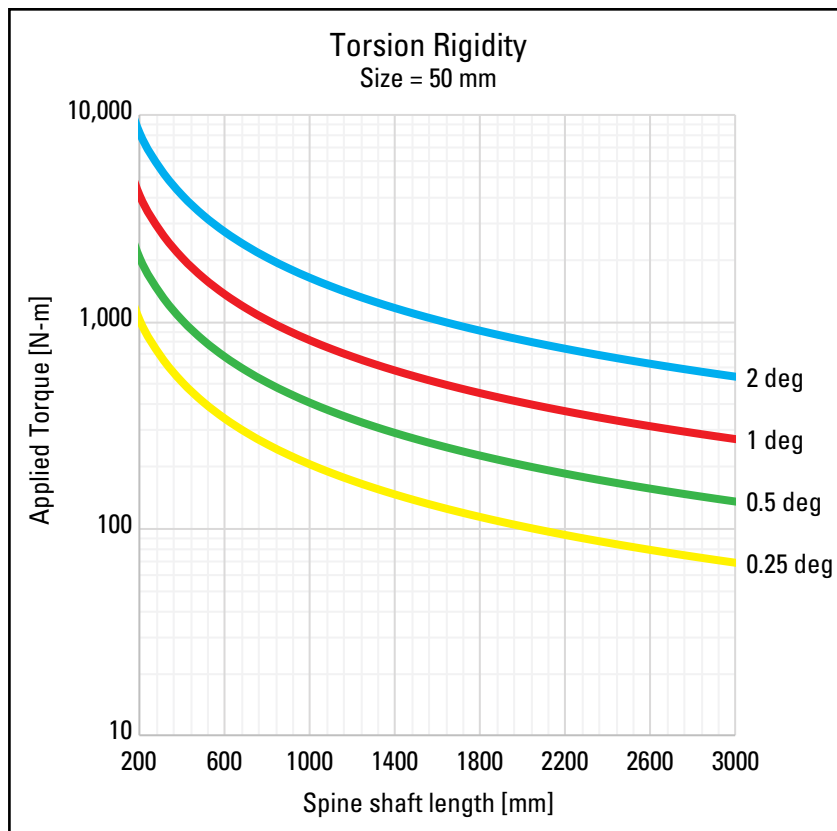
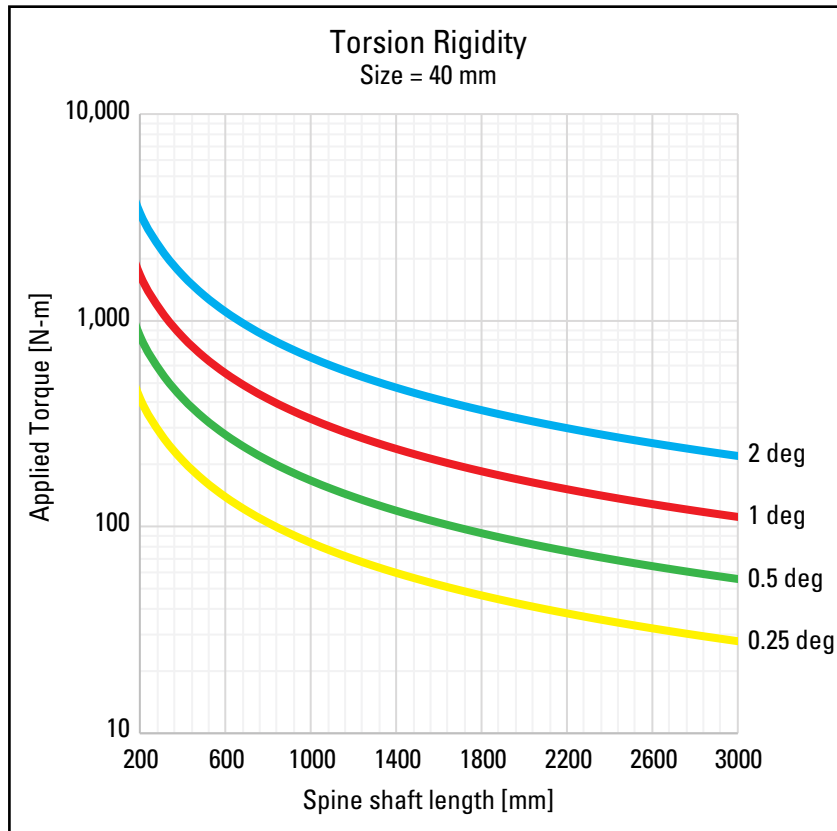

Spline Shaft Strength

Deflection and Deflection Angle of the Spline Shaft

Calculate by using equations that satisfy the relevant operating conditions. Table 1 presents the operating conditions and the corresponding equations. Table 2 presents the cross-section factors (Z) and cross-section secondary moments (I). Through the use of the Z, I values given in these tables, the strength and degree of displacement (deflection) of ball spline model can be obtained.

Table 1 Deflection and Deflection-Angle Equation			
End Fixity	Operational Conditions	Moment Equation	Deflection Equation
Fixed - Free		$M = P_c \cdot l$	$\delta = \frac{P_c l^3}{3EI}$
Simple - Simple		$M = \frac{P_c \cdot l}{4}$	$\delta = \frac{P_c l^3}{48EI}$
Fixed - Simple		$M = \frac{3P_c \cdot l}{16}$	$\delta = \frac{P_c l^3}{48EI\sqrt{5}}$

Table 1 Deflection and Deflection-Angle Equation

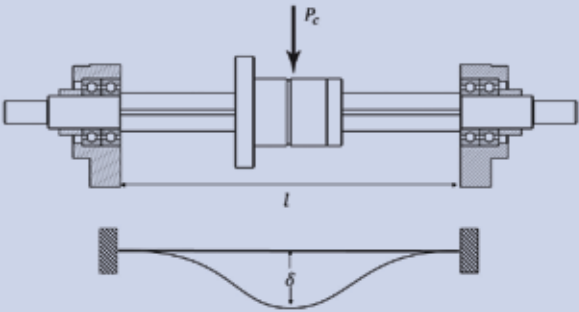
End Fixity	Operational Conditions	Moment Equation	Deflection Equation
Fixed - Fixed		$M = \frac{P_c \cdot l}{8}$	$\delta = \frac{P_c l^3}{192EI}$

δ : Maximum Deflection (mm)

P_c : Concentrated Load (N)

E : Longitudinal Elastic Modulus 2.06×10^5 (N/mm)

l : Span (mm)

I : Geometrical Moment of Inertia (mm⁴)

Table 2 Cross-Section Factors and Secondary Moments

Nominal Diameter	Geometrical moment of inertia, I (mm ⁴)	Polar moment of inertia, I_p (mm ⁴)	Section modulus, Z (mm ³)	Polar section modulus, Z_p (mm ³)
SPLS006NS RL0500	63.49	119.23	18.58	39.74
SPLS008NS RL0500	200.93	387.53	46.65	96.88
SPLS010NS RL3000	490.25	933.29	86.61	186.66
SPLS013NS RL3000	1400.81	2691.54	198.57	414.08
SPLS016NS RL3000	3215.60	6242.70	378.39	780.34
SPLS020NS RL3000	7851.80	15336.59	748.48	1533.66
SPLS025NS RL3000	18466.30	36932.60	1477.30	2954.61
SPLS030NS RL3000	33122.31	77392.48	2579.75	4416.31
SPLS040NS RL3000	120667.43	241334.90	6033.37	12066.74
SPLS050NS RL3000	274691.98	594247.50	11884.95	23769.90

Spline Shaft Critical Speed

When an operating ball spline reaches critical speed, mechanical resonance occurs and no further operation can be performed. Namely, to keep a ball spline under ideal operation, the speed limit must be monitored. Therefore, to set an ideal operational speed for safety, factor must be settled as 80% of critical speed as shown in equation (6).

Critical Speed

$$(6) N_c = \frac{60\lambda^2}{2\pi \cdot l_b^2} \sqrt{\frac{E \cdot I \cdot 10^3}{\gamma A}}$$

N_c : Critical Shaft Speed (min^{-1})

l_b : Support Distance (mm)

E : Young's Modulus ($2.06 \cdot 10^5 \text{ N/mm}^2$)

I : Moment of Inertia of the Shaft (mm^4)

$$(7) I = \frac{\pi}{64} d_1^4 \quad d_1 = \text{Obtained from table on page 34}$$

d_1 : Inner Diameter (mm)

γ : Density (Specific Gravity) ($7.85 \cdot 10^{-6} \text{ kg/mm}^3$)

$$(8) A = \frac{\pi}{4} d_1^2 \quad d_1 = \text{Obtained from table on page 34}$$

d_1 : Inner Diameter (mm)

A : Spline-Shaft Cross-Sectional Area (mm^2)

λ : Installation-Method-Dependent Factor

(Fig. 1)

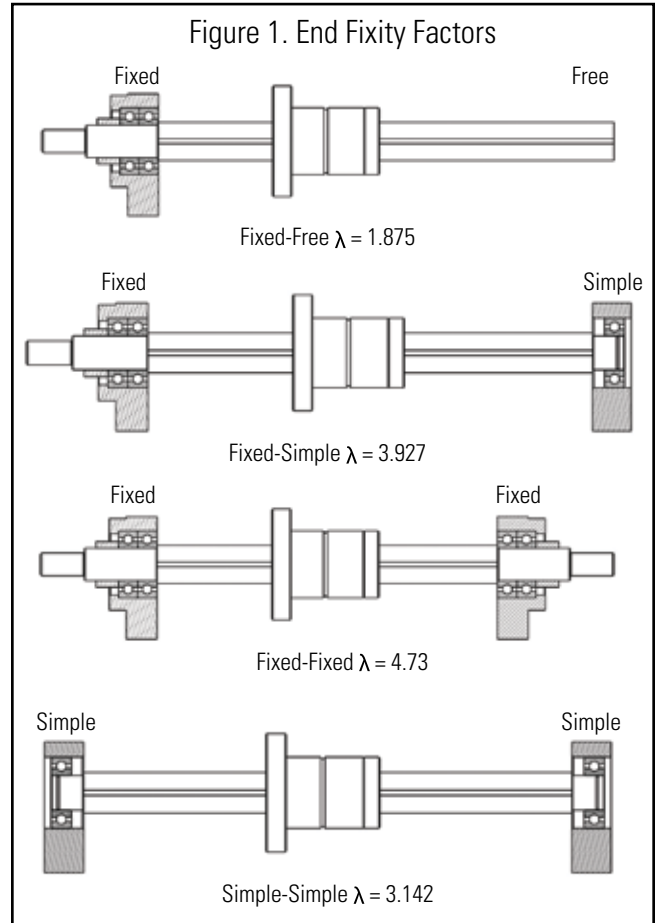

Critical Speed

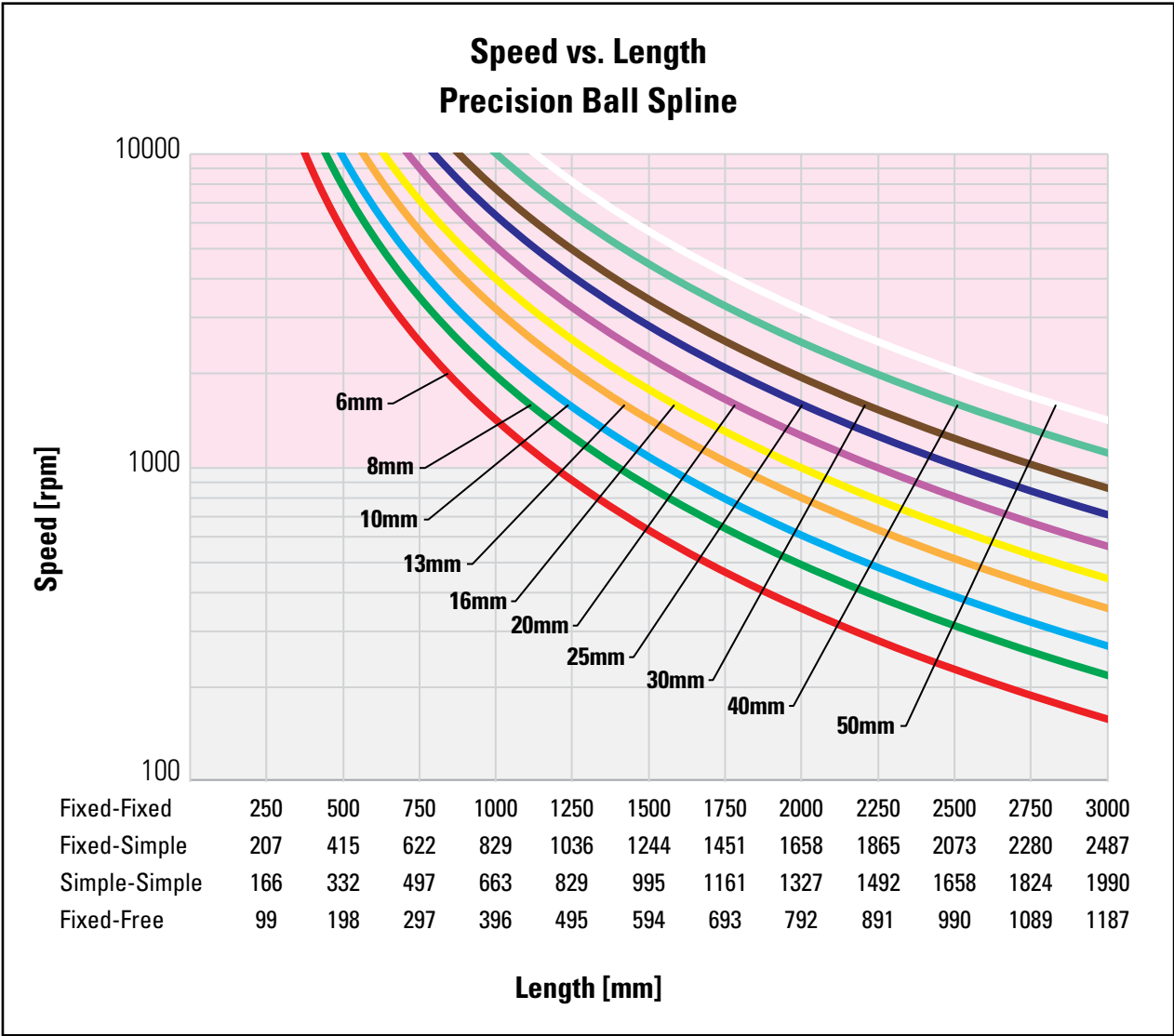

Expected Service Life

Nominal Service Life

Thomson defines the nominal service life of precision ball splines as 90% of the average running distance before flaking within the ball spline on the same manufacturing cycle. Please note that the nominal life expectancy is only for reference.

Calculating Nominal Service Life

The factors influencing the service life for precision ball splines can be attributed to three main factors: the torque, radial load and moment (Fig 2). The influence of each can be calculated through equations (9) to (13).

Under a Torque

$$(9) L = \left(\frac{f_T \cdot f_c}{f_w} \cdot \frac{C_T}{T_c} \right)^3 \cdot 50$$

Under a Raial Load

$$(10) L = \left(\frac{f_T \cdot f_c}{f_w} \cdot \frac{C}{P_c} \right)^3 \cdot 50$$

L : Nominal Service Life (km)

C_T : Basic Dynamic-Torque (N-m)

T_c : Calculated Torque Applied (N-m)

C : Basic Dynamic Load Rating (N)

P_c : Radial Load (N)

f_T : Temperature (See Fig. 3)

f_c : Contact (See Table 4)

f_w : Load Factor (See Table 5)

Under both a moment and radial load applied simultaneously

Calculate the service life from the sum of the radial load and the equivalent radial load.

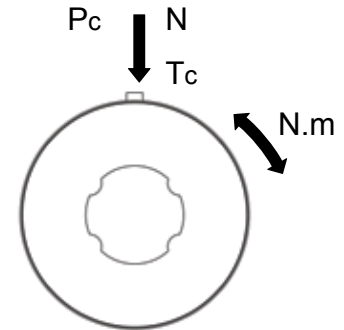

Figure 2. Service Life Factors

Under both a torque and radial load applied simultaneously

In this case, calculate the equivalent torque by equation (11) to determine service life by equation (12).

$$(11) T_e = T_c + \left(P_c \frac{C_t}{T_e} \right)$$

$$(12) L = \left(\frac{f_t \cdot f_c}{f_q} \cdot \frac{C_T}{T_e} \right)^3 \cdot 50$$

Spline Shaft Life Expectancy charts can be used for determining life base on equivalent torque.

Under a moment on a spline nut or two closely attached to one another

Obtain the equivalent radial load using the equation, and determine the service life by equation (13).

$$(13) P_U = K \cdot M$$

P_U : Equivalent Radial Load (N)(Moment Applied)

K : Equivalent Factor (See Table 3)

M : Applied Moment (N-mm)

However, M should be within the range of the static permissible moment.

Table 3 Equivalent Factor

Model Number	Equivalent Factor : K	
	One Spline Nut	Two Spline Nuts
SL 06	0.577	0.065
SL 08	0.577	0.059
SL 10	0.418	0.047
SL 13	0.360	0.043
SL 16	0.229	0.033
SL 20	0.201	0.029
SL 25	0.154	0.023
SL 30	0.126	0.021
SL 32	0.114	0.019
SL 40	0.110	0.016
SL 50	0.109	0.013

Expected Service Life

Calculating Nominal Service Life

Once the nominal life (L) is obtained, if the stroke length and the number of reciprocal operations are consistent, the service life (in hours) can be obtained by using equation (14).

$$(14) L_h = \frac{L \cdot 10^3}{2 \cdot \ell_S \cdot n_1 \cdot 60}$$

L_h : Service Life in Hours (h)

ℓ_S : Stroke Length (m)

n_1 : Number of Reciprocal Operations per Minute (min^{-1})

Temperature Factor (f_T)

When the ball spline operates in an environment in which the temperature reaches 212°F (100°C) or higher, consider that the heat may adversely affect its operation. To avoid malfunction under extreme temperature, Fig. 3 should be taken into consideration. The ball spline material should be heat resistant and customized when used in extreme environments.

Note: Please contact Thomson for upgrading the material for operation in environments exceeding 176°F (80°C). Seal and retainer materials should be upgraded to sustain higher temperatures.

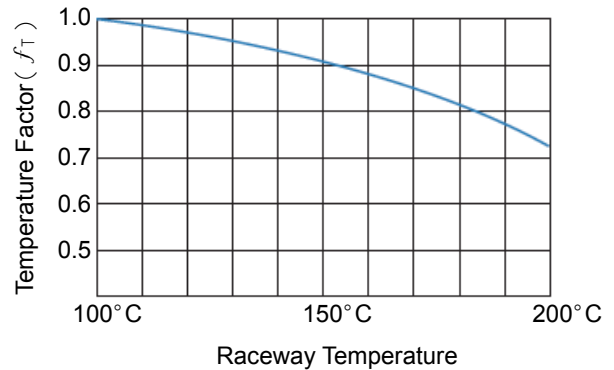

Figure 3. Temperature Factor (f_T)

Contact Factor (f_c)

When one or more spline nuts are closely mounted on the spline shaft, their linear motion is affected by moment loads and mounting accuracy, resulting in non-uniform load distribution. When closely linked spline nuts are used, multiply the basic load rating (C or C_o) by one of the contact factors specified below.

Note: If a non-uniform load distribution is expected, such as large equipment, take the contact factor explained in Table 4 into account.

No. of Spline Nuts Linked	f_c
2	0.81
3	0.72
4	0.66
5	0.61
In Normal Use	1.0

Load Factor (f_w)

The operation of reciprocal machines is likely to cause vibration and impact. It is difficult to determine the rating of vibration, potential impact or repeated impact during high-speed operation. When operating conditions create vibration, take the basic load rating (C or C0) and multiply that value by the load factor that corresponds to the correct vibration level (See Table 5).

Vibration Impact	Velocity	f_c
Minor	Minor velocity $V \leq 0.25$ m/s	1-1.2
Little	Low velocity $0.25 < V \leq 1.0$ m/s	1.2-1.5
Medium	Medium velocity $1.0 < V \leq 2.0$ m/s	1.5-2.0
Heavy	High velocity $V > 2.0$ m/s	2.0-3.5

Calculating the Average Applied Load

The applied load fluctuates during operation. For instance, the ball spline nut receives variable loads during the operation of an industrial robotic arm, which initiates with a workpiece and returns without one. The fluctuation of applied load influences the service life of ball splines, therefore, the calculation of service life must take such fluctuation into consideration. When the service life of a ball spline with variable load is equal to the one with a certain load, then that certain load is called the mean load. See equation (15) below.

$$(15) P_m = \sqrt[3]{\frac{1}{L} \cdot \sum_{n=1}^n (P_n^3 \cdot L_n)}$$

P_m : Mean Load (N)

P_n : Fluctuating Load (N)

L : Total Stroke

L_n : Stroke under Load P_n (mm)

Spline Shaft Life Expectancy

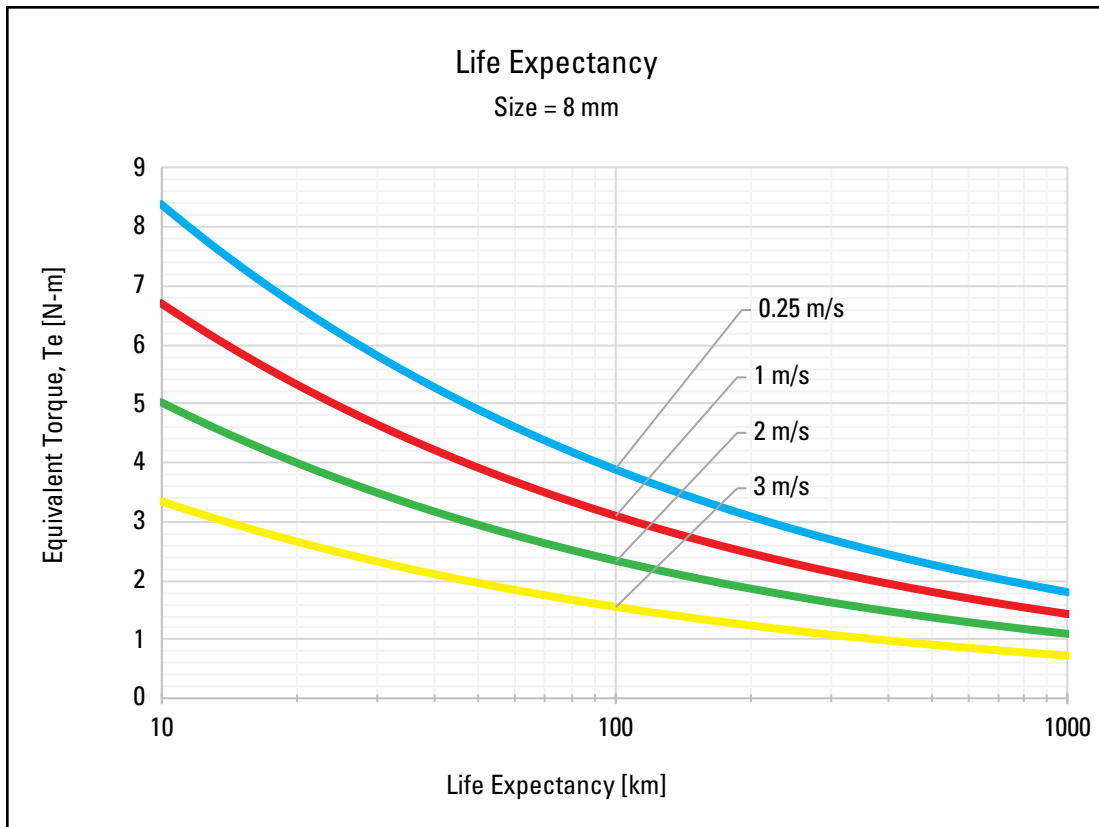
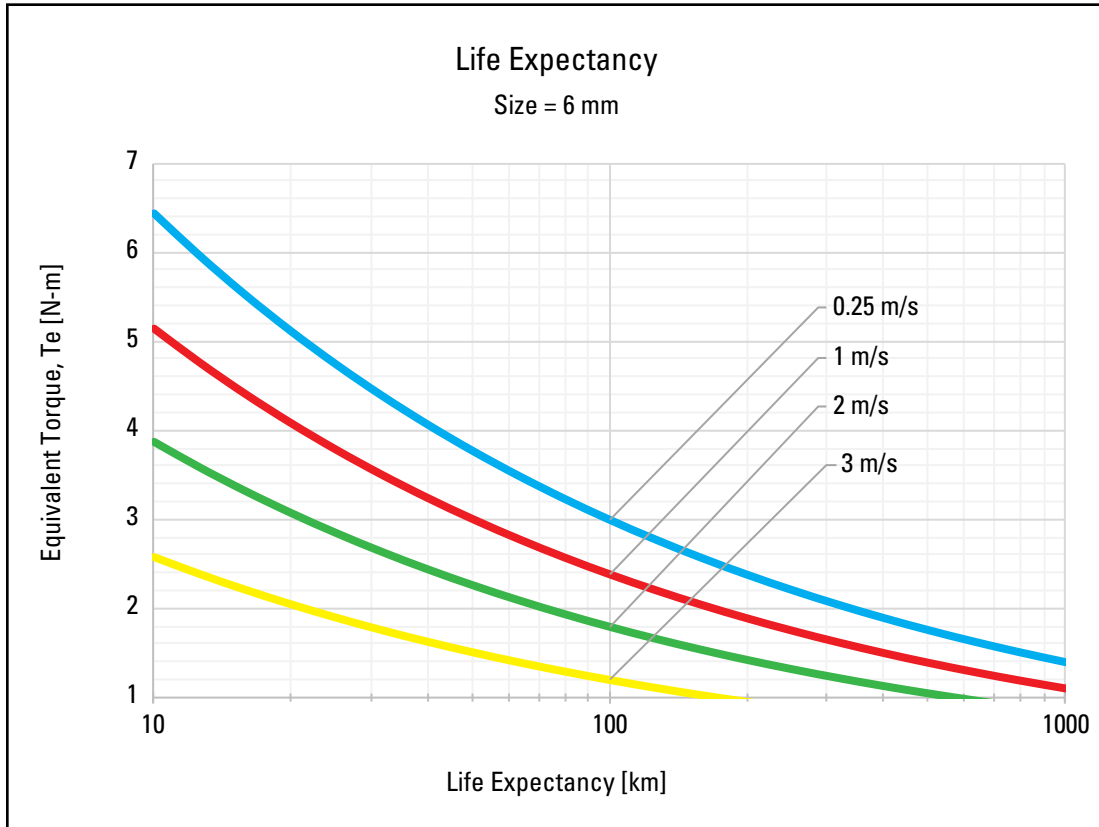

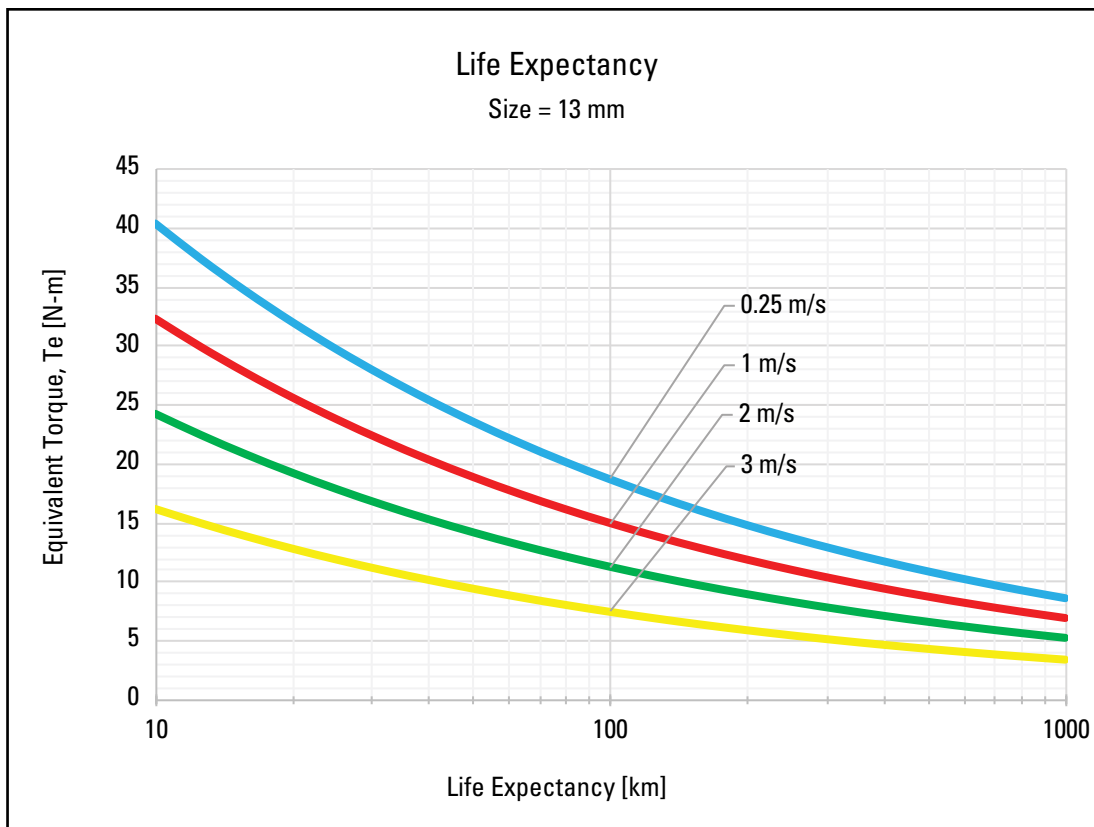
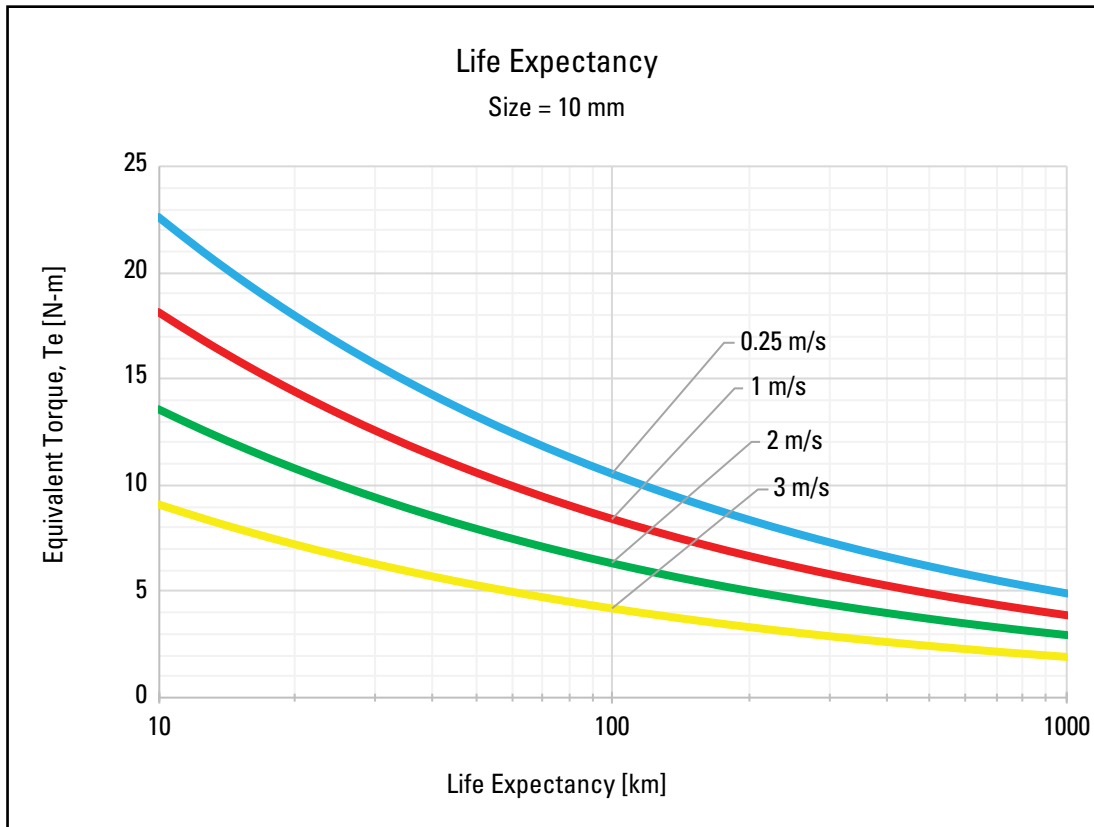

Spline Shaft Life Expectancy

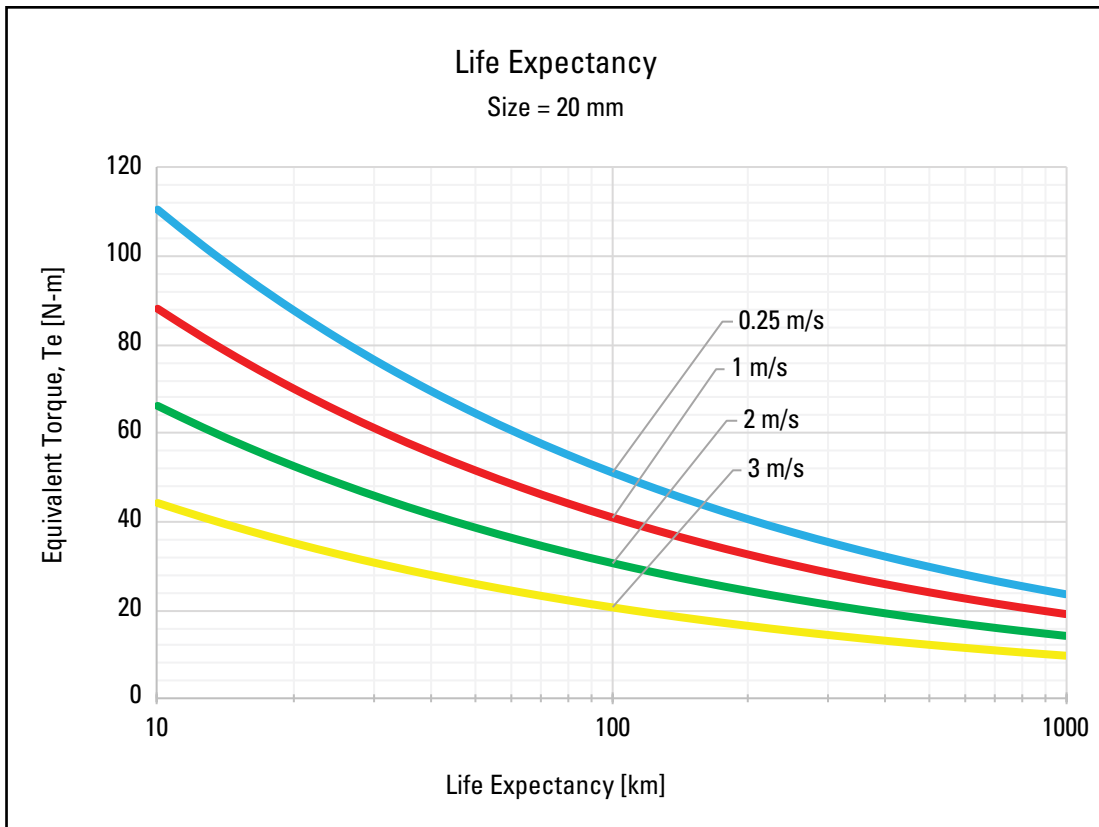
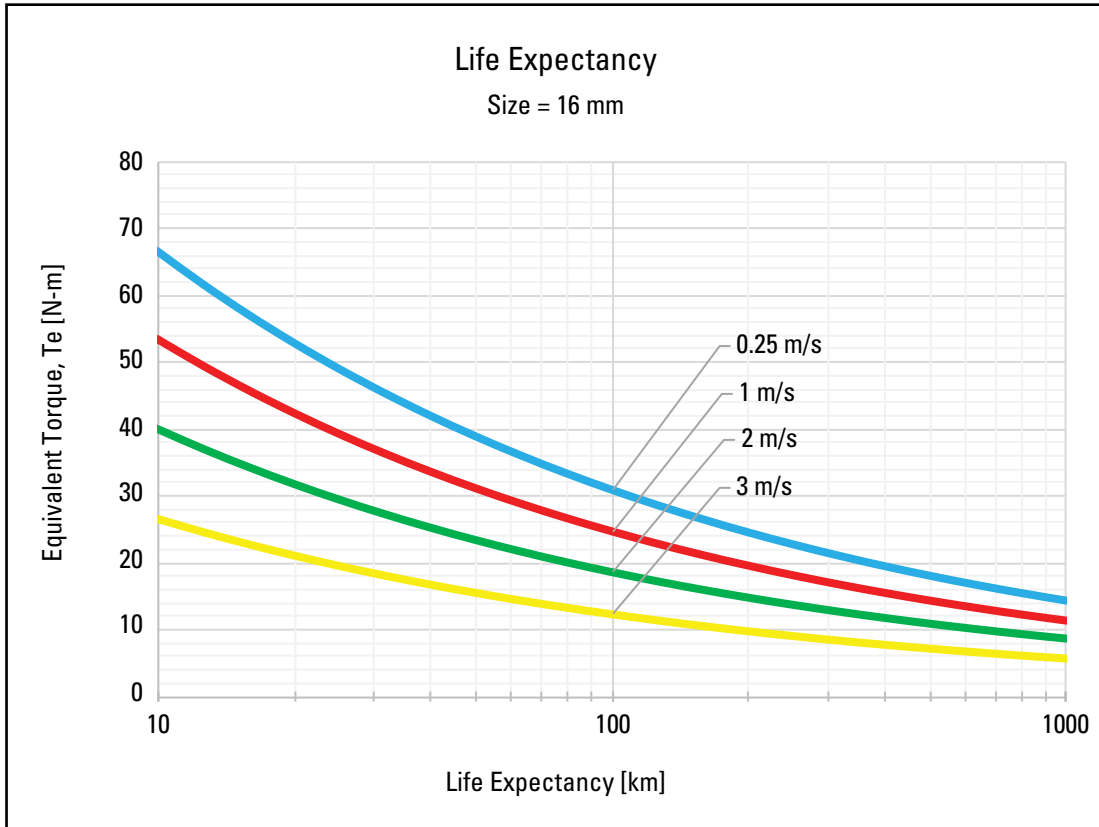

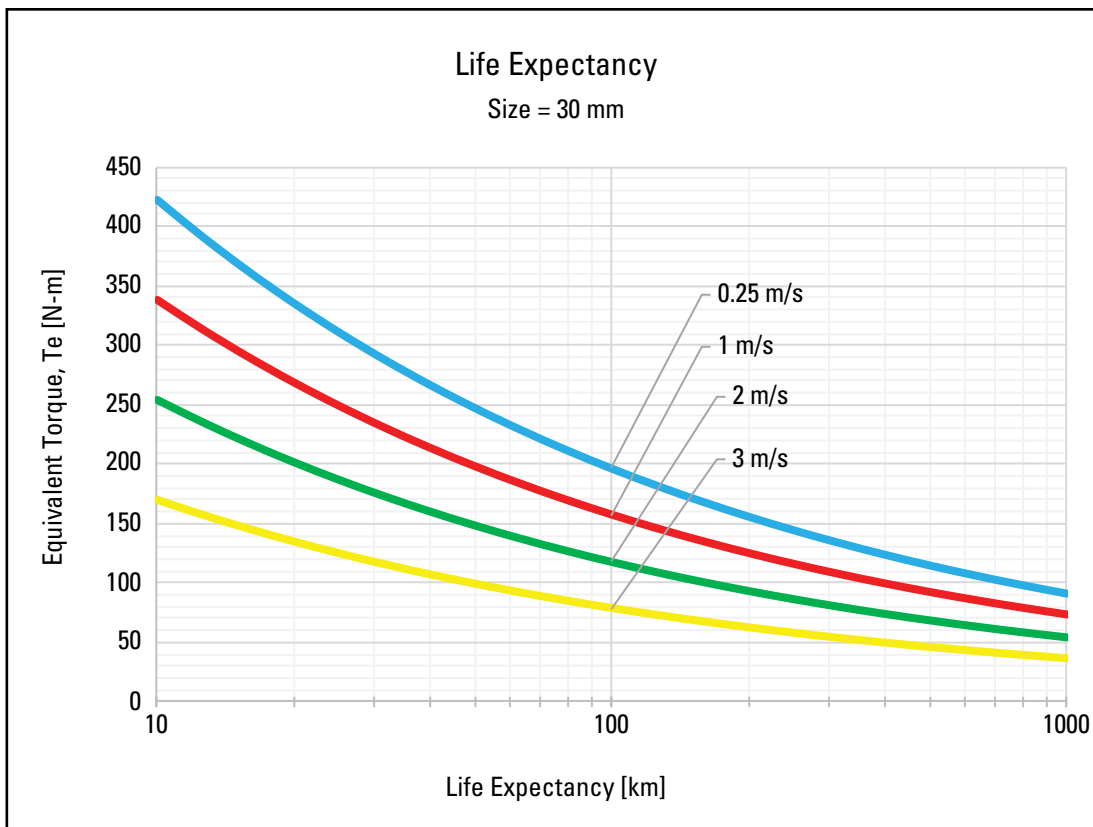
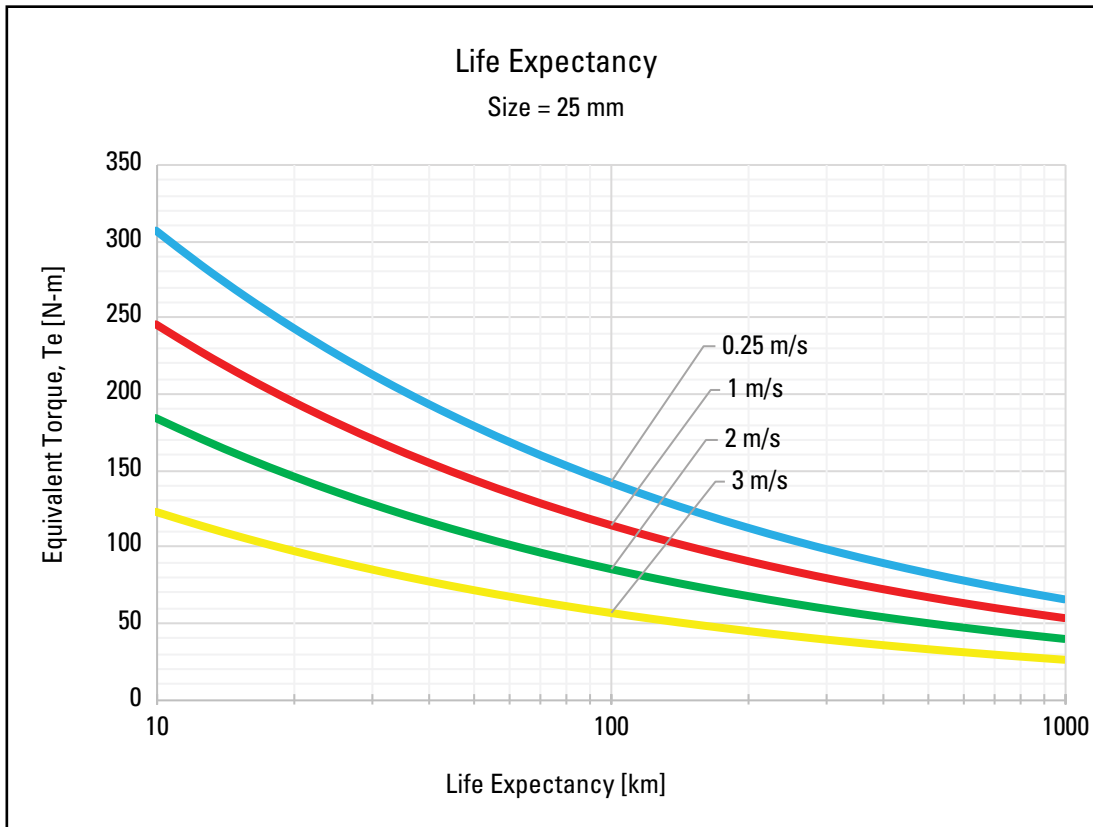

Spline Shaft Life Expectancy

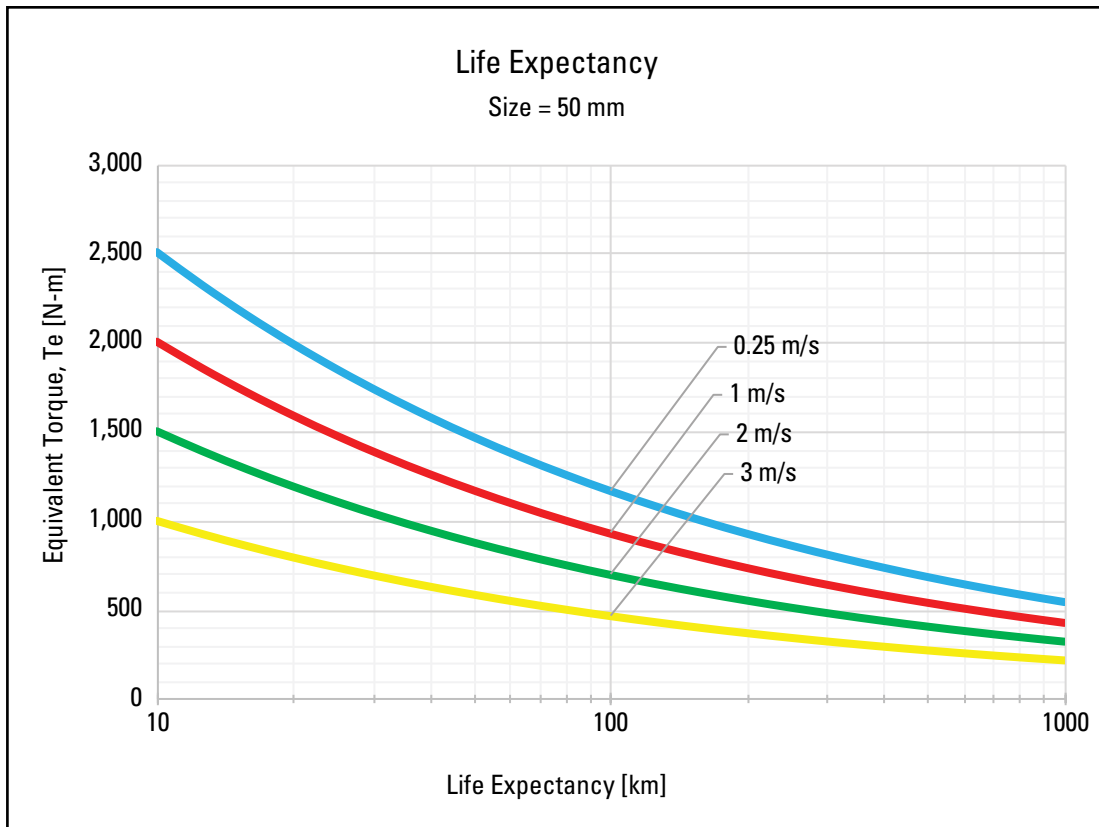
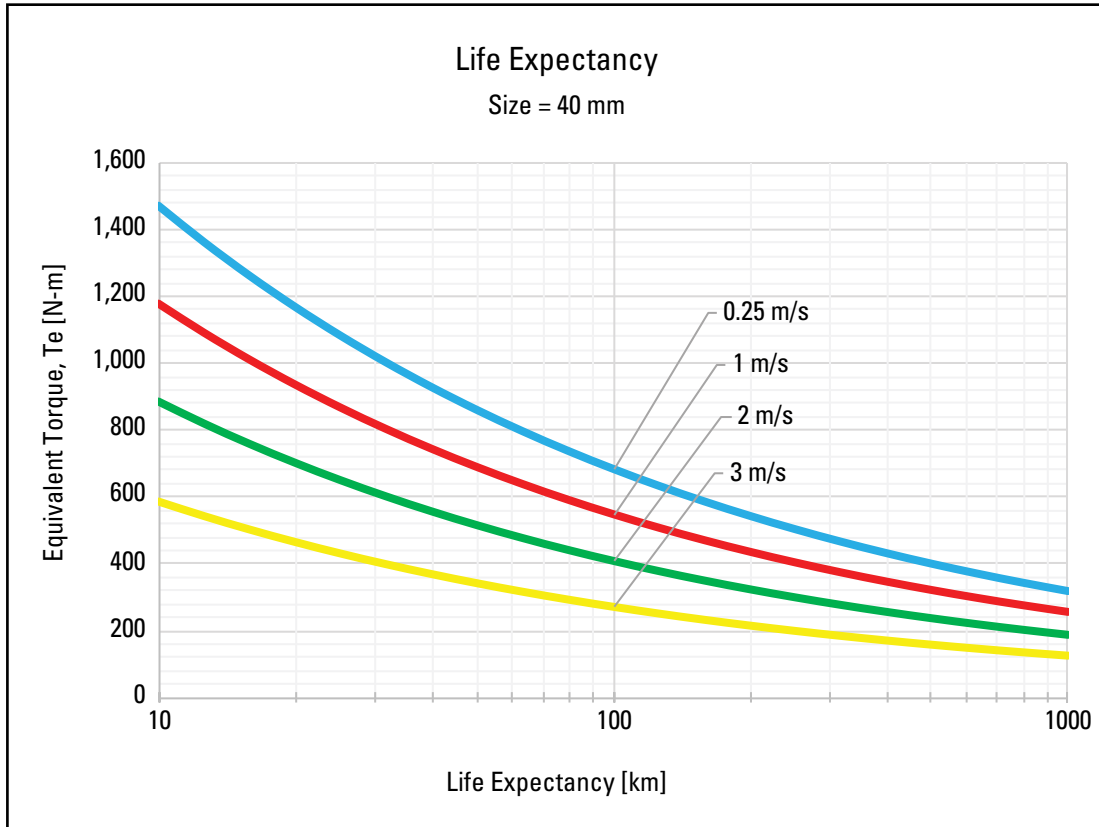

Accuracy

Accuracy Grade

The accuracy of precision ball splines is determined by the spline nut and thus divided into three accuracy grades of Normal (N), High (H) and Precision (P).

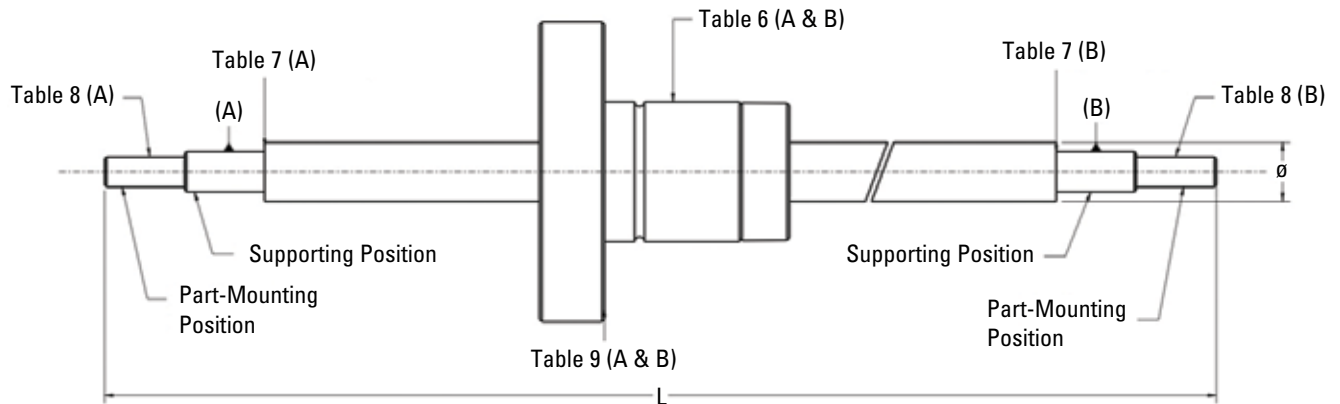

Accuracy Specifications

Tables 6 to 9 indicate the tolerance of ball spline call out.

Table 6 Spline Nut Tolerance of Support Unit						
Length / Diameter (mm)		6, 8	10	12, 13, 15, 16, 20	25, 30	40, 50
Above	Below	Normal Precision (microns)				
-	200	72	59	56	53	53
200	315	133	83	71	58	58
315	400	185	103	83	70	63
400	500	236	123	95	78	68
500	630	-	151	112	88	74
630	800	-	190	137	103	84
800	1000	-	-	170	124	97
1000	1250	-	-	-	151	114

Table 7 Maximum Perpendicularity of Spline Shaft on Journal Ends

Nominal Diameter (mm)	Accuracy (microns)
6, 8, 10	22
13, 16, 20	27
25, 30	33
40, 50	39

Table 8 Maximum Radial Call Out on Attached Surface

Nominal Diameter (mm)	Accuracy (microns)
6, 8	33
10	41
13, 16, 20	46
25, 30	53
40, 50	62

Table 9 Perpendicularity of Flange on the Attached Surface

Nominal Diameter (mm)	Normal (N)
6, 8	17
10, 13	33
16, 20, 25, 30	30
40, 50	46

Dimensional Drawings and Load Data

Solid Spline Shaft (SLF, Spline Shaft Cross-Sectional Shape)

The figures below indicate the cross-section of the spline shaft. When the shaft end is a round pillar type, the minor diameter must not be greater than the diameter of the groove ridge.

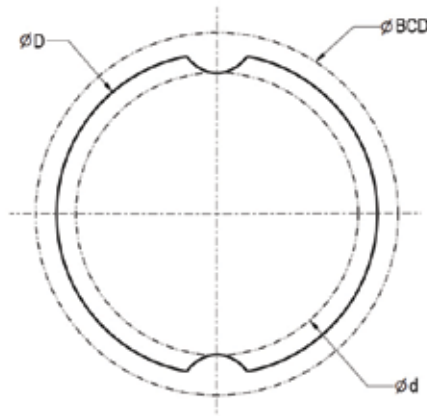

$D \leq 20$

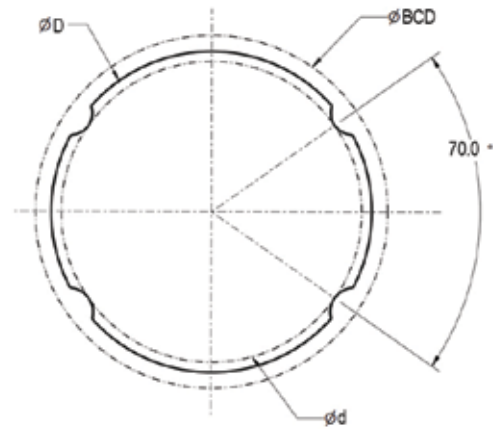

$D \geq 25$

	Nominal Diameter (Units in mm)									
	6 mm	8 mm	10 mm	13 mm	16 mm	20 mm	25 mm	30 mm	40 mm	50 mm
Inner Diameter $\varnothing d$	5.25	7.27	8.98	11.82	14.72	18.63	23.43	28.53	37.3	47.05
Outer Diameter $\varnothing D$ h7	6	8	10	13	16	20	25	30	40	50
Weight (kg/m)	0.22	0.39	0.6	1.03	1.56	2.44	3.8	5.49	9.69	15.19
Ball Center Diameter $\varnothing BCD$	6.75	8.77	11.35	14.6	17.5	21.8	27	32.1	43.65	54.2
Tolerance μm	0 -15	0 -15	0 -18	0 -18	0 -18	0 -21	0 -21	0 -25	0 -25	0 -30

Precision Ball Spline Flange Nut

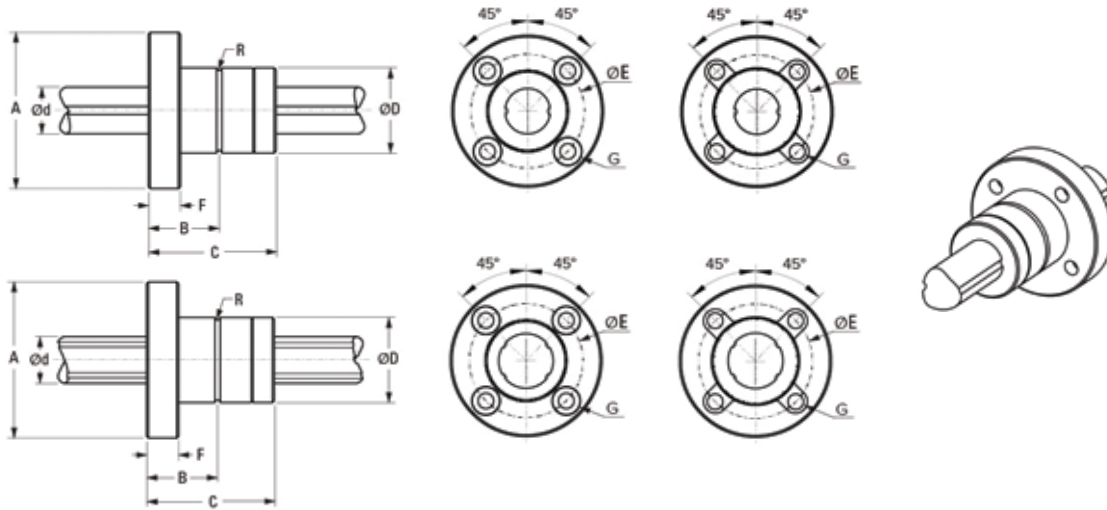

Ball Spline Flange Nut and Precision Spline Shaft (Dimensions in millimeters)

Part Number		Spline Shaft Diameter	Flange Dia.	Groove Distance	Overall Length	Housing Diameter	Flange Thickness	Thru Hole Dia.	CB Hole Dia.	CB Hole Dia. Depth
Spline Flange Nut	Spline Shaft	Ød h7	A	B	C	ØD h6	F	G	Y	Z
SPLS006FS	SPLS006NS RL0500	6/5.988	30	7.5	25	14/13.989	6	3.4	6.5	3.5
SPLS008FS	SPLS008NS RL0500	8/7.985	32	7.5	27	16/15.989	8	3.4	6.5	4.5
SPLS010FS	SPLS010NS RL3000	10/9.989	42	10.5	33	21/20.987	9	4.5	8	4
SPLS013FS	SPLS013NS RL3000	13/12.982	44	11	36	24/23.984	9	4.5	8	4.5
SPLS016FS	SPLS016NS RL3000	16/15.982	51	18	50	31/30.98	10	4.5	8	6
SPLS020FS	SPLS020NS RL3000	20/19.979	58	18	56	35/34.984	10	5.5	9.5	5.4
SPLS025FS	SPLS025NS RL3000	25/24.979	65	26.5	71	42/41.984	13	5.5	9.5	8
SPLS030FS	SPLS030NS RL3000	30/29.929	75	30	80	47/46.984	13	6.6	11	8
SPLS040FS	SPLS040NS RL3000	40/39.975	100	36	100	64/63.981	18	9	14	12
SPLS050FS	SPLS050NS RL3000	50/49.975	124	46.5	125	80/79.981	20	11	17.5	12

Spline Flange Nut Part Number	Basic Load Rating		Basic Torsion		Static Permissible Moment		Weight	
	C	C ₀	C _T	C _{0T}	M _{A1}	M _{A2}	Split Nut	Spline Shaft
	kN	kN	N - m	N - m	N - m	N - m	g	kg/m
SPLN006FS	1.343	2.206	4.511	7.453	3.824	34.127	36.7	0.22
SPLN008FS	1.343	2.206	5.883	9.708	3.824	37.461	47	0.39
SPLN010FS	2.794	3.893	15.886	22.064	9.316	83.650	100	0.6
SPLN013FS	3.903	5.295	28.341	38.638	14.709	122.190	117	1.03
SPLN016FS	5.344	8.325	46.777	72.863	36.382	255.855	226	1.56
SPLN020FS	7.100	10.875	77.472	118.562	54.230	372.652	303	2.44
SPLN025FS	9.836	15.621	215.648	421.784	101.498	672.638	458	3.80
SPLN030FS	11.375	19.417	296.749	617.132	153.768	914.666	633	5.49
SPLN040FS	21.145	39.550	1033.327	1726.461	358.825	2415.77	1430	9.69
SPLN050FS	40.069	55.064	1764.118	2984.654	505.827	4204.307	2756	15.19

Dimensional Drawings and Data

Precision Ball Spline Cylindrical Nut

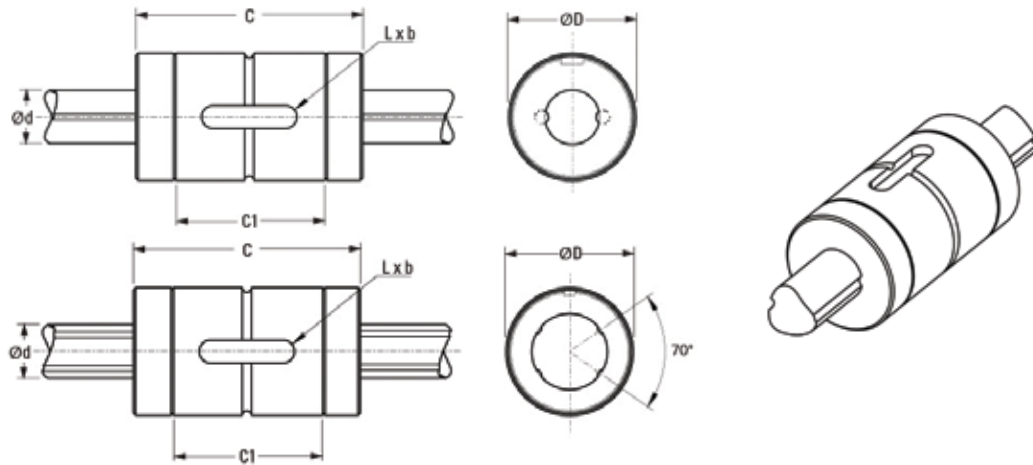

Ball Spline Cylindrical Nut and Precision Spline Shaft (Dimensions in millimeters)

Part Number		Spline Shaft Diameter	Overall Length	Overall Length	Housing Diameter	Keyway Length	Keyway Width	
Spline Cylindrical Nut	Spline Shaft	Ød h7	C	C1	ØD h6	L +0/-0.2	b h9	
SPLS006RS	SPLS006NS RL0500	6/5.988	25	16.7	14/13.989	10.5/10.3	2.5/2.475	
SPLS008RS	SPLS008NS RL0500	8/7.985	27	15.7	16/15.989	10.5/10.3	2.5/2.475	
SPLS010RS	SPLS010NS RL3000	10/9.989	33	20	21/20.987	13/12.8	3/2.975	
SPLS013RS	SPLS013NS RL3000	13/12.982	36	23	24/23.984	15/14.8	3/2.975	
SPLS016RS	SPLS016NS RL3000	16/15.982	50	34	31/30.98	17.5/17.3	3.5/3.475	
SPLS020RS	SPLS020NS RL3000	20/19.979	56	39.7	35/34.984	29/28.8	4/3.970	
SPLS025RS	SPLS025NS RL3000	25/24.979	71	50.3	42/41.984	36/35.8	4/3.970	
SPLS030RS	SPLS030NS RL3000	30/29.929	80	60	47/46.984	42/41.8	4/3.970	
SPLS040RS	SPLS040NS RL3000	40/39.975	100	70	64/63.981	6/5.97	6/5.970	
SPLS050RS	SPLS050NS RL3000	50/49.975	125	91	80/79.981	8/7.97	8/7.964	
Spline Cylindrical Nut Part Number	Basic Load Rating		Basic Torsion		Static Permissible Moment		Weight	
	C	C ₀	C _T	C _{0T}	M _{A1}	M _{A2}	Spline Nut	Spline Shaft
	kN	kN	N - m	N - m	N - m	N - m	g	kg/m
SPLN006FS	1.343	2.206	4.511	7.453	3.824	34.127	14	0.22
SPLN008FS	1.343	2.206	5.883	9.708	3.824	37.461	16	0.39
SPLN010FS	2.794	3.893	15.886	22.064	9.316	83.650	37	0.6
SPLN013FS	3.903	5.295	28.341	38.638	14.709	122.190	52	1.03
SPLN016FS	5.344	8.325	46.777	72.863	36.382	255.855	130	1.56
SPLN020FS	7.100	10.875	77.472	118.562	54.230	372.652	188	2.44
SPLN025FS	9.836	15.621	215.648	421.784	101.498	672.638	285	3.80
SPLN030FS	11.375	19.417	296.749	617.132	153.768	914.666	395	5.49
SPLN040FS	21.145	39.550	1033.327	1726.461	358.825	2415.77	843	9.69
SPLN050FS	40.069	55.064	1764.118	2984.654	505.827	4204.307	1758	15.19

Lubrication

The spline nut is pre-lubricated prior to shipment for immediate use, and the maintenance period varies according to the operating conditions. Thomson suggests that under normal operating conditions to lubricate your ball spline after 62 miles (100 km) or six months of operation. Apply lubricant within the nut body or on the groove of the spline shaft.

Ball Spline Precautions

General Maintenance

- (1) Disassembling ball splines without the supervision of a certified engineer may cause malfunction of the ball spline.
- (2) Gravity causes the spline nut to slide when aligning the ball spline. Please handle with care.
- (3) Do not hammer or allow the ball spline to free fall as this may damage the ball spline and hinder its performance.
- (4) Prevent debris or scraps from intervening the ball spline as it may decrease its performance or lead to malfunction.
- (5) Prevent the ball spline from operating under extreme conditions. Contact Thomson customer service when you intend on using your ball spline under extreme conditions.

Lubrication

- (1) Remove anti-dust oil before sealing the ball spline with grease.
- (2) Prevent mixing of different kinds of grease as it will cause unexpected chemical deformities.
- (3) Please contact a certified engineer for consulting the use of grease when the ball spline is designed to operate under frequent vibration, vacuum, or extremely high- or low-temperature conditions.
- (4) Please consult a certified engineer for the use of non-certified grease.
- (5) When using motor oil to serve the purpose of lubrication, be aware that it may cause a decline in performance due to improper installation. Please consult a certified engineer.

Storage

Avoid extreme temperatures and humidity when storing ball splines. Please use certified seals and store in a horizontal position.

Mounting

Tolerance on Support Unit

Ball spline nuts and their support units are bored to minimize clearance. If high accuracy is not required, a clearance fit can be used.

Support Unit Tolerance	
Condition	Tolerance within Support Unit
General Operating Condition	H7
Operation Under Minimal Axial Clearance	J6

Ball Spline Installation

The installation of a ball spline is shown as in Table. Though the strength of mounting is not strictly required, the user must be certain that the spline shaft is firmly fixed on the support unit.

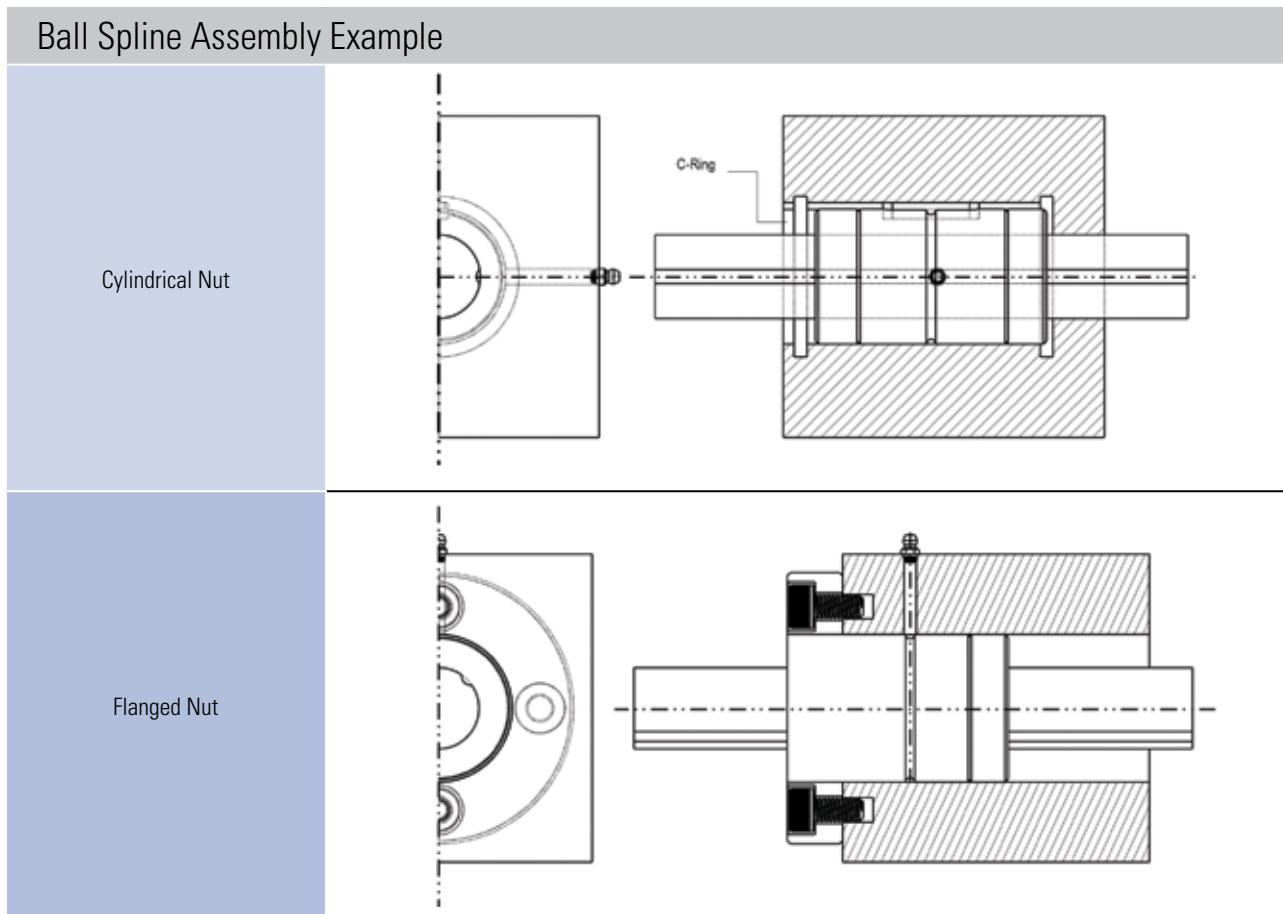

Spline Nut Installation

When installing a spline nut into the spline shaft, use a jig shown in the figure below to insert the spline with care.

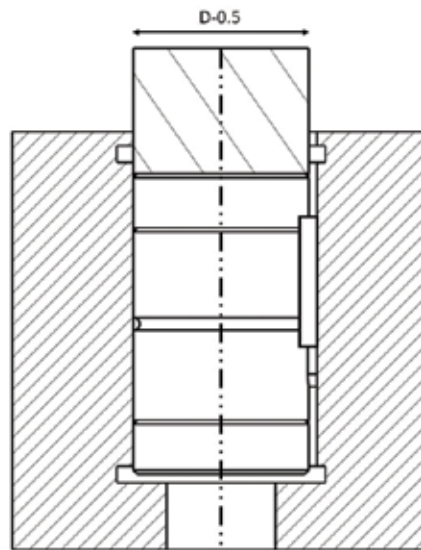

Jig Specifications

Nominal Diameter	6	8	10	13	16	20	25	30	40	50
di	5.0	7.0	8.5	11.5	14.5	18.5	23	28	37.5	46.5

Online Resources

Thomson offers a wide variety of online application, selection and training tools to help you in the precision ball spline selection process. An experienced team of engineers is also available to help size and select a precision ball spline to best fit your application needs. To explore additional technical resources and options, contact customer support at www.thomsonlinear.com/cs.

Ball Splines on the Web

Find additional information and learn more about precision ball splines on this content-rich web page. <https://www.thomsonlinear.com/spl-overview>



Interactive 3D CAD Models

Download free interactive 3D CAD models in the most common CAD formats.

<https://www.thomsonlinear.com/spl-cad>



Selector Tool

This tool greatly simplifies the tasks of searching and selecting with a visual selection process that immediately narrows down your precision ball spline options. <https://www.thomsonlinear.com/spl>



USA, CANADA and MEXICO

Thomson
203A West Rock Road
Radford, VA 24141, USA
Phone: 1-540-633-3549
Fax: 1-540-633-0294
E-mail: thomson@thomsonlinear.com
Literature: literature.thomsonlinear.com

EUROPE

United Kingdom

Thomson
Office 9, The Barns
Caddsdawn Business Park
Bideford, Devon, EX39 3BT
Phone: +44 1271 334 500
E-mail: sales.uk@thomsonlinear.com

Germany

Thomson
Nürtinger Straße 70
72649 Wolfschlügen
Phone: +49 7022 504 403
Fax: +49 7022 504 405
E-mail: sales.germany@thomsonlinear.com

France

Thomson
Phone: +33 243 50 03 30
E-mail: sales.france@thomsonlinear.com

Italy

Thomson
Via per Cinisello 95/97
20834 Nova Milanese (MB)
Phone: +39 0362 366406
Fax: +39 0362 276790
E-mail: sales.italy@thomsonlinear.com

Spain

Thomson
E-mail: sales.esm@thomsonlinear.com

Sweden

Thomson
Estridsväg 10
29109 Kristianstad
Phone: +46 44 590 2400
Fax: +46 44 590 2585
E-mail: sales.scandinavia@thomsonlinear.com

ASIA

Asia Pacific

Thomson
E-mail: sales.apac@thomsonlinear.com

China

Thomson
Rm 805, Scitech Tower
22 Jianguomen Wai Street
Beijing 100004
Phone: +86 400 606 1805
Fax: +86 10 6515 0263
E-mail: sales.china@thomsonlinear.com

India

Kollmorgen – Div. of Altra Industrial Motion
India Private Limited
Unit no. 304, Pride Gateway,
Opp. D-Mart,
Baner Road, Pune, 411045
Maharashtra
Phone: +91 20 67349500
E-mail: sales.india@kollmorgen.com

South Korea

Thomson
3033 ASEM Tower (Samsung-dong)
517 Yeongdong-daero
Gangnam-gu, Seoul, South Korea (06164)
Phone: + 82 2 6001 3223 & 3244
E-mail: sales.korea@thomsonlinear.com

SOUTH AMERICA

Brazil

Thomson
Av. João Paulo Ables, 2970
Jardim da Glória - Cotia SP - CEP: 06711-250
Phone: +55 11 4615 6300
E-mail: sales.brasil@thomsonlinear.com

www.thomsonlinear.com

Precision_Ball_Splines_BREN-0046-01 | 20220926BH
Specifications are subject to change without notice. It is the responsibility of the product user to determine the suitability of this product for a specific application. All trademarks property of their respective owners. ©2022Thomson Industries, Inc.

Linear Motion. Optimized.™